



(51) International Patent Classification:  
A61F 2/40 (2006.01)

(21) International Application Number:  
PCT/US2022/034245

(22) International Filing Date:  
21 June 2022 (21.06.2022)

(25) Filing Language: English

(26) Publication Language: English

(30) Priority Data:  
63/223,694 20 July 2021 (20.07.2021) US

(71) Applicant: **HOWMEDICA OSTEONICS CORP.**  
[US/US]; 325 Corporate Drive, Mahwah, NJ 07430 (US).

(72) Inventors: **TERRILL, Lance Nathan**; 528 Green Cedar Drive, League City, TX 77573 (US). **CAMPBELL, Garrett**; 46 Colonial Drive, Huntington, NY 11743 (US).

(74) Agent: **APICELLI, Samuel W.**; Duane Morris LLP, 30 South 17th Street, Philadelphia, PA 19103 (US).

(81) Designated States (unless otherwise indicated, for every kind of national protection available): AE, AG, AL, AM, AO, AT, AU, AZ, BA, BB, BG, BH, BN, BR, BW, BY, BZ, CA, CH, CL, CN, CO, CR, CU, CZ, DE, DJ, DK, DM, DO, DZ, EC, EE, EG, ES, FI, GB, GD, GE, GH, GM, GT, HN, HR, HU, ID, IL, IN, IQ, IR, IS, IT, JM, JO, JP, KE, KG, KH, KN, KP, KR, KW, KZ, LA, LC, LK, LR, LS, LU, LY, MA, MD, ME, MG, MK, MN, MW, MX, MY, MZ, NA, NG, NI,

NO, NZ, OM, PA, PE, PG, PH, PL, PT, QA, RO, RS, RU, RW, SA, SC, SD, SE, SG, SK, SL, ST, SV, SY, TH, TJ, TM, TN, TR, TT, TZ, UA, UG, US, UZ, VC, VN, WS, ZA, ZM, ZW.

(84) Designated States (unless otherwise indicated, for every kind of regional protection available): ARIPO (BW, GH, GM, KE, LR, LS, MW, MZ, NA, RW, SD, SL, ST, SZ, TZ, UG, ZM, ZW), Eurasian (AM, AZ, BY, KG, KZ, RU, TJ, TM), European (AL, AT, BE, BG, CH, CY, CZ, DE, DK, EE, ES, FI, FR, GB, GR, HR, HU, IE, IS, IT, LT, LU, LV, MC, MK, MT, NL, NO, PL, PT, RO, RS, SE, SI, SK, SM, TR), OAPI (BF, BJ, CF, CG, CI, CM, GA, GN, GQ, GW, KM, ML, MR, NE, SN, TD, TG).

Published:  
— with international search report (Art. 21(3))



WO 2023/003660 A1

(54) Title: GLENOID IMPLANTS

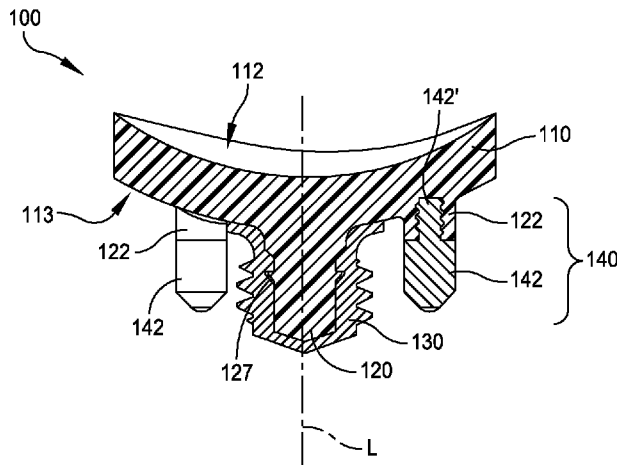

FIG. 1B

(57) Abstract: Various embodiments of novel glenoid implant are disclosed.

## GLENOID IMPLANTS

### CROSS-REFERENCE TO RELATED APPLICATION

[0001] This application claims priority to U.S. Provisional Application No. 63/223,694, filed July 20, 2021, the entirety of which is incorporated by reference herein.

### FIELD OF DISCLOSURE

[0002] The present disclosure generally relates to glenoid implants for shoulder prosthesis.

### BACKGROUND

[0003] A shoulder prosthesis includes a glenoid implant intended to replace the glenoid cavity of the scapula and/or a humeral implant intended to replace the humeral head. The glenoid implant generally includes an articular body intended to articulate with the humeral head, and a fixation means to stabilize the articular body with respect to the scapula.

[0004] Conventional revisable glenoid implants utilizing metal baseplate design use bone screws for baseplate fixation. However, bone screws have limited potential for long-term fixation, because bone is viscoelastic and relaxes over time. The typical use of bone screws is in an array of 4-5 mm diameter screws. This array is not only expensive and requires significant intraoperative time to prepare and guide the screw trajectories, but also the clinical literature shows occasional screw breakage below the screw head.

[0005] Thus, improved glenoid implant design that offers enhanced and durable primary fixation to the bone is desired.

### SUMMARY

[0006] Provided herein are various embodiments of a glenoid implant that provides a bearing surface for the glenoid that incorporate a large screw design, having a diameter from 5 - 20 mm, to create enhanced fixation strength with the glenoid than using conventional bone screws.

[0007] Also provided is a glenoid implant for implantation in a glenoid, the implant comprising: an articular body comprising an articulation surface and an anchoring surface on opposite side of the articular body; at least one protrusion integrally formed with the articular body and extending from the anchoring surface; and a fixation element provided for each of the at least one protrusion, wherein each fixation element comprising: a proximal end, a distal end, a longitudinally-extending recess extending distally from the proximal end, and a screw-

threaded external surface, wherein the at least one protrusion and the corresponding fixation element are configured for snap-fitting engagement when the at least one protrusion is inserted into the longitudinally-extending recess of the fixation element.

[0008] Also provided is a glenoid implant comprising: an articular body comprising an articulation surface and an anchoring surface on opposite side of the articular body; two protrusions that are integrally formed with the articular body and extending from the anchoring surface; and one fixation element provided for each of the two protrusions, wherein each fixation element comprising: a proximal end, a distal end, a longitudinally-extending recess extending distally from the proximal end, and a screw-threaded external surface, wherein the two protrusions and the corresponding fixation element are configured for snap-fitting engagement when the two protrusions are inserted into the close-ended recess of the corresponding fixation element.

#### BRIEF DESCRIPTION OF THE DRAWINGS

[0009] The various embodiments of the inventive hydrogel implant of the present disclosure will be described in more detail in conjunction with the following drawing figures. The structures in the drawing figures are illustrated schematically and are not necessarily intended to show actual dimensions or relative scale.

[0010] FIG. 1A is an isometric view of a glenoid implant according an embodiment of the present disclosure.

[0011] FIG. 1B is a cross-sectional view of the glenoid implant of FIG. 1A.

[0012] FIG. 1C is a side view of a protrusion **120** extending from the anchoring surface of the glenoid implant of FIG. 1A showing the profile of the protrusion.

[0013] FIG. 1D is a cross-sectional view of a fixation element **130**.

[0014] FIG. 2A is an isometric view of a glenoid implant according to another embodiment of the present disclosure.

[0015] FIG. 2B is another isometric view of the glenoid implant of FIG. 2A.

[0016] FIG. 2C is a sideview of the glenoid implant of FIG. 2A.

[0017] FIG. 2D is a cross-sectional view of the glenoid implant of FIG. 2A.

[0018] FIG. 2E is a sideview of a protrusion **220** extending from the anchoring surface of the glenoid implant of FIG. 2A showing the profile of the protrusion.

[0019] FIG. 2F is a cross-sectional view of the fixation element **230, 230'**.

[0020] FIG. 2G is a cross-sectional view of another embodiment of the glenoid implant of FIG. 2A.

[0021] FIG. 2H is an isometric view of the glenoid implant of FIG. 2A, without the fixation elements **230**, **230'**.

#### DETAILED DESCRIPTION

[0022] This description of the exemplary embodiments is intended to be read in connection with the accompanying drawings, which are to be considered part of the entire written description. The drawing figures are not necessarily to scale and certain features may be shown exaggerated in scale or in somewhat schematic form in the interest of clarity and conciseness. In the description, relative terms such as "horizontal," "vertical," "up," "down," "top" and "bottom" as well as derivatives thereof (e.g., "horizontally," "downwardly," "upwardly," etc.) should be construed to refer to the orientation as then described or as shown in the drawing figure under discussion. These relative terms are for convenience of description and normally are not intended to require a particular orientation. Terms including "inwardly" versus "outwardly," "longitudinal" versus "lateral" and the like are to be interpreted relative to one another or relative to an axis of elongation, or an axis or center of rotation, as appropriate. Terms concerning attachments, coupling and the like, such as "connected" and "interconnected," refer to a relationship wherein structures are secured or attached to one another either directly or indirectly through intervening structures, as well as both movable or rigid attachments or relationships, unless expressly described otherwise. When only a single machine is illustrated, the term "machine" shall also be taken to include any collection of machines that individually or jointly execute a set (or multiple sets) of instructions to perform any one or more of the methodologies discussed herein. The term "operatively connected" is such an attachment, coupling or connection that allows the pertinent structures to operate as intended by virtue of that relationship. In the claims, means-plus-function clauses, if used, are intended to cover the structures described, suggested, or rendered obvious by the written description or drawings for performing the recited function, including not only structural equivalents but also equivalent structures.

[0023] Provided herein are various improved glenoid implants that have articulation surface that is configured to engage with an anatomical humeral head or a humeral component of a shoulder replacement implant system. Therefore, references to "a humeral head" as used herein should be construed to include both an anatomical humeral head as well as implant humeral head.

[0024] Referring to FIGS. 1A-1D, an improved glenoid implant **100** for implantation in a glenoid according to the present disclosure is provided. The implant **100** comprises an

articular body **110**, at least one protrusion **120** integrally formed with the articular body, and a fixation element or a hub **130** provided for each of the at least one protrusion. The fixation element **130** is configured to receive a corresponding protrusion **120**. The fixation element can be first inlaid into the glenoid, then the articular body is installed in place by inserting the corresponding protrusion **120** into the fixation element **130** and securing it in place.

[0025] The articular body **110** comprises an articulation surface **112** and an anchoring surface **113** on the opposite side of the articulation body. The at least one protrusion **120** extends from the anchoring surface **113**. Each of the fixation element **130** comprises a proximal end **131** (proximal with respect to the articular body **110**), a distal end **132** (distal with respect to the articular body **110**), a longitudinally-extending recess **135**, for receiving the corresponding protrusion **120**, extending distally from the proximal end, and a screw-threaded external surface **133**. The longitudinally-extending recess **135** can be open-ended and in some embodiments, it can be close-ended. The screw threads on the external surface **133** can be self-tapping threads.

[0026] Each of the fixation element and the corresponding protrusion **120** can be configured to engage each other securely. In some examples, the longitudinally-extending recess **135** and the corresponding protrusion **120** can be configured for a snap-fitting engagement when the protrusion is inserted into the recess **135**.

[0027] In some embodiments, each of the at least one protrusion **120** can comprise one or more substantially radially extending tabs **127** provided on the exterior surface of the protrusion **120** and the recess **135** in each of the fixation element **130** can comprise a corresponding annular groove **137**, where the one or more substantially radially extending tabs **127** and the annular groove **137** can engage each other to form the snap-fitting engagement.

[0028] In some embodiments, the snap-fitting engagement can be achieved by the use of a C-clip or an O-ring. For example, instead of the one or more substantially radially extending tabs **127** on the exterior surface of the protrusion **120**, a c-clip or an O-ring can be provided over a recess that circumscribes the exterior surface of the protrusion **120** so that when the protrusion **120** is inserted into the recess **135**, the c-clip or the O-ring gets captured between the recess on the exterior surface of the protrusion **120** and the annular groove **137** thus forming the snap-fitting engagement.

[0029] In the embodiments in which the recess **135** is a close-ended recess, the fixation element **130** can further comprise a guide hole **138** that is used to guide the fixation element **130** over a guide pin during the implant surgical procedure which is described below.

[0030] In some embodiments, the substantially radially extending tab **127** can be a single annular continuous collar-like tab on the protrusion **120**. In some embodiments, the annular collar-like structure can be discontinuous and be divided into two or more segments, thus, forming two or more radially extending tabs on the protrusion **120**. This would be similar to the way the radially extending tabs **227** and **227'** extend around the protrusions **220**, **220'** with some discontinuity as shown in FIG. 2H. Either way, as long as the segmented tabs are positioned along an annular collar-like arrangement on the surface of the protrusion **120**, the radially extending tabs **127** can engage with one annular groove **137** on the fixation element **130**.

[0031] In some embodiments, the articular body **110** and the integrally formed radially extending tabs **127** can be formed of, whole or in part, of a high modulus synthetic material. Polymers such as, for example, polyethylene (e.g. ultra-high-molecular-weight polyethylene (UHMWPE)), polyether ether ketone (PEEK), etc. that are selected to provide the desired performance for the articulation surface **112** can be used. All references to UHMWPE herein includes all variants of UHMWPE in orthopedic application such as vitamin E diffused UHMWPE.

[0032] The fixation element **130** is formed of a material that is more rigid, i.e., has a higher Young's modulus, than the protrusion **120**. According to some embodiments, the fixation element **130** can be metallic and/or ceramic. For example, the fixation element **130** can be made from titanium, stainless steel, an alloy of titanium, and/or an alloy of cobalt-chromium, or a biocompatible ceramic. In some embodiments, the metallic fixation element **130** can be coated with a coating that promotes bone in-growth. An example of such coating material is a porous metallic coating ADAPTIS™ by Wright Medical Technology.

[0033] With the fixation element **130** being more rigid than the one or more substantially radially extending tabs **127**, when one of the at least one protrusion **120** is inserted into the recess **135** of a fixation element **130**, the one or more substantially radially extending tabs **127** elastically deform as the protrusion **120** advances into the recess **135** and snaps back into the original shape when the radially extending tabs **127** reaches the annular groove **137**, thus forming the snap-fitting engagement.

[0034] As shown in FIGS. 1B and 1C, each of the at least one protrusion **120** defines a longitudinal axis **L**. To form the snap-fitting engagement, the one or more substantially radially extending tabs **127** extend toward the anchoring surface **113**, i.e., in the proximal direction, so that the leading surface **127a** of the one or more substantially radially extending

tabs **127** form an acute angle  $\alpha$  with the longitudinal axis **L** toward the anchoring surface **113**. The leading surface **127a** is referred to herein as a “leading” surface because that is the side of the radially extending tabs **127** that is facing the recess **135** of the fixation element **130** when the protrusion **120** and the fixation element **130** engage each other to form the snap-fitting engagement.

[0035] The recess **135** comprises a sidewall **136** and the annular groove **137** is cut into the sidewall **136**. The annular groove **137** comprises distal face **137a** and a proximal face **137b**, that correspond to the leading surface **127a**, and the trailing surface **127b** of the one or more radially extending tabs **127**, respectively. The distal face **137a** form the acute angle  $\alpha$  with the longitudinal axis **L** toward the anchoring surface **113** when the at least one protrusion **120** is in snap-fitting engagement with the fixation element **130**.

[0036] The fixation element **130** has an outer diameter of that is between 5 - 25 mm. Preferably, the outer diameter is between 6.5 – 20 mm, more preferably between 6.5 – 15 mm, and most preferably between 9 – 15 mm. The ranges provided for the outer diameter are inclusive of the endpoints.

[0037] In some embodiments, the glenoid implant **100** comprises one protrusion **120** and one fixation element **130**.

[0038] In some embodiments, each of the at least one protrusion **120** can have a split collet structure to further enhance the snap-fitting engagement between the protrusion **120** and the fixation element **130**. The collet structure can be seen in FIG. 2H where examples of such protrusions **220**, **220'** on the glenoid implant **200** are illustrated.

[0039] In some embodiments, the glenoid implant **100**, further comprises one or more additional fixation features **140** extending from the anchoring surface **113** configured to prevent rotation of the articular body **110** with respect to the glenoid when the glenoid implant **100** is implanted in the glenoid. Each of the one or more fixation features **140** can be a structure in the form of a post, as in the illustrated example of FIGS. 1A-1B, a finned anchor, or a keel. The glenoid would be prepared appropriately to receive the one or more fixation features **140** depending on the shape of the fixation features **140**.

[0040] In the illustrated example, each of the one or more fixation features **140** is a metallic peg **142** that is co-molded with the articular body **110** which is a polymer. As shown in the sectional view in FIG. 1B, the metallic peg **142** comprises a thinner stem portion **142'** onto which the polymer articular body material is co-molded. Preferably, the surface of the stem portion **142'** is textured so that the co-molded interface between the articular body **110**

and the stem portion **142'** is stronger. In some embodiments, the surface of the stem portion **142'** can be threaded. The co-molded portion forms a base **122** of the fixation feature **140**. In some embodiments, the metallic pegs **142** can be made of such material as Tritanium<sup>®</sup> by Stryker Corp. which is a porous material, or other porous metallic material, to enhance bone tissue in-growth and, thus, further enhance the fixation of the implant **100** to the glenoid.

[0041] In some embodiments of the glenoid implant **100**, each of the at least one protrusion **120** has a split collet structure.

[0042] The overall outline shape of the glenoid implant body **110** and the curvature of the anchoring surface **113** are configured to match the patient's glenoid. To install the glenoid implant **100**, the glenoid surface is prepared with a first hole to receive the fixation element **130** and additional holes or slots positioned around the first hole to match the arrangement of the positions of the one or more fixation features **140** with respect to the fixation element **130** as shown in FIG. 1A.

[0043] During the surgical procedure for implanting the glenoid implant **100**, after the glenoid is prepared to form a concave surface for receiving the glenoid implant **100**, a pilot hole of an appropriate diameter is drilled into the glenoid for receiving the fixation element **130** so that the screw threads **133** can tap into the pilot hole and allow the fixation element **130** to be threaded into the pilot hole. Then, with the distal end **132** of the fixation element **130** facing toward the pilot hole in the glenoid, the fixation element **130** is threaded into the pilot hole until the proximal end **131** of the fixation element is flush with the surface of the glenoid.

[0044] When using the embodiment of the fixation element **130** whose longitudinally-extending recess **135** is close-ended, a guide pin can be inserted into bottom of the pilot hole at the center of the pilot hole. Then, the fixation element **130** is placed over the guide pin using the guide hole **138**, so that the distal end **132** of the fixation element **130** is facing toward the pilot hole in the glenoid. The fixation element **130** is then slid down the guide pin until the distal end **132** of the fixation element **130** reaches the pilot hole. Then the fixation element **130** is threaded into the pilot hole until the proximal end **131** of the fixation element is flush with the surface of the glenoid.

[0045] At some point during these steps, before the implant body **110** can be installed, holes are drilled into the glenoid for receiving the one or more fixation features **140**. Next, the implant body **110** is installed by aligning the protrusion **120** with the recess **135** in the

fixation element **130** and aligning the one or more fixation features **140** with the corresponding holes prepared in the glenoid then pushing the protrusion **120** into the recess **135** until the snap-fitting engagement is achieved.

[0046] One of the benefits of the glenoid implant **100** is that if a revision of the implant is required, the structure of the glenoid implant **100** allows removal of the implant body **110** with minimal damage to the glenoid, if any. To remove the implant body **110**, the fixation features **140** can be cut at the co-molded polymer base structure **122**. Once the fixation features **140** are cut, the assembly of the implant body **110** and the fixation element **130** can be removed by unscrewing the assembly from the glenoid. Then, the metallic posts **142** can be pulled out of the glenoid.

[0047] Referring to FIGS. 2A-2H, according to another embodiment, a glenoid implant **200** is also disclosed. The glenoid implant **200** comprises an articular body **210**, two protrusions **220**, **220'** and one fixation element **230**, **230'** provided for each of the two protrusions. The articular body **210** comprises an articulation surface **212** and an anchoring surface **213** on opposite side of the articular body **210**. The two protrusions **220**, **220'** are integrally formed with the articular body and extend from the anchoring surface **213**. Each fixation element **230**, **230'** have the same structure as the fixation element **130** described above. Each fixation element **230**, **230'** comprises a proximal end, a distal end, a longitudinally-extending recess **235**, **235'** extending distally from the proximal end, and a screw-threaded external surface.

[0048] As in the glenoid implant embodiment **100**, the two protrusions **220**, **220'** and the corresponding fixation elements **230**, **230'** are configured for snap-fitting engagement when the two protrusions are inserted into the recess **235**, **235'** of the corresponding fixation element **230**, **230'**.

[0049] In some embodiments, each of the protrusions **220**, **220'** can have a split collet structure to further enhance the snap-fitting engagement between the protrusions **220**, **220'** and the fixation elements **230**, **230'**. The collet structure can be seen in FIG. 2H where examples of such protrusions **220**, **220'** on the glenoid implant **200** are illustrated.

[0050] FIGS. 2A and 2B are labeled to show the superior side and the inferior side of the implant **200** indicating the implanted orientation in the patient. To accommodate the physical dimensions of a glenoid where the inferior portion is larger than the superior portion, the

superiorly located fixation element **230'** of the glenoid implant **200** has a smaller diameter than the inferiorly located fixation element **230**.

[0051] Referring to FIG. 2E, similar to the protrusions **120** in the glenoid implant **100**, each of the two protrusions **220**, **220'** in the glenoid implant **200** comprises one or more substantially radially extending tabs **227**, **227'**, respectively, provided on exterior surfaces of the protrusions. Each fixation element **230**, **230'** are provided with a longitudinally-extending recess **235**, **235'**. The longitudinally-extending recess **235**, **235'** can be open-ended and in some embodiments, it can be close-ended.

[0052] Each of the recesses **235**, **235'** in each fixation elements **230**, **230'** comprises an annular groove **237**, **237'**, where the one or more substantially radially extending tabs **227**, **227'** and the annular grooves **237**, **237'** form the snap-fitting engagement when the protrusions **220**, **220'** are pushed into their respective recesses **235**, **235'**. As described above in conjunction with the glenoid implant **100**, the snap-fitting engagement can be formed using a c-clip or an O-ring captured between the protrusions **220**, **220'** and their respective recesses **235**, **235'**.

[0053] Each of the two protrusions **220**, **220'** defines a longitudinal axis **L** and the corresponding one or more substantially radially extending tabs **227**, **227'** extend toward the anchoring surface **213** so that a leading surface **227a**, **227a'** of the one or more substantially radially extending tabs form an acute angle  $\alpha$  with the longitudinal axis **L** toward the anchoring surface **213**.

[0054] The recess **235**, **235'** in each fixation element **230**, **230'** comprises a sidewall **236**, **236'** and the annular groove **237**, **237'** is cut into the sidewall, wherein the annular groove comprises a distal face **237a**, **237a'** and a proximal face **237b**, **237b'** that correspond to the leading surface **227a**, **227a'**, and the trailing surface **227b**, **227b'** of the radially extending tabs **227**, respectively. The leading surface **227a**, **227a'** and the distal face **237a**, **237a'** form an angle with the longitudinal axis **L** toward the anchoring surface **213** that is substantially the acute angle  $\alpha$  when the two protrusions **220**, **220'** are in snap-fitting engagement with the corresponding fixation elements **230**, **230'**. Each of the fixation elements **230**, **230'** further comprise a guide hole **238**, **238'**, respectively, that is used to guide the fixation element over a guide pin during the implant surgical procedure which is described below.

[0055] Because of the geometry of the glenoid is not circular but asymmetric, one of the two fixation elements **230**, **230'** is the larger diameter fixation element that satisfy the outer

diameter requirement of between 5 – 25 mm. Preferably, the outer diameter is between 6.5 – 20 mm, more preferably between 6.5 – 15 mm, and most preferably between 9 – 15 mm. The outer diameter ranges provided are inclusive of the endpoints. In the illustrated example glenoid implant **200**, the fixation element **230** is the larger diameter fixation element.

[0056] In some embodiments, the articular body **210** and the integrally formed radially extending tabs **227**, **227'** can be formed of, whole or in part, of a high modulus synthetic material. Polymers such as, for example, polyethylene (e.g. ultra-high-molecular-weight polyethylene (UHMWPE)), polyether ether ketone (PEEK), etc. that are selected to provide the desired performance for the articulation surface **212** can be used. All references to UHMWPE herein includes all variants of UHMWPE in orthopedic application such as vitamin E diffused UHMWPE.

[0057] The fixation elements **230**, **230'** are formed of a material that is more rigid, i.e., has a higher Young's modulus, than the protrusions **220**, **220'**. According to some embodiments, the fixation element **230**, **230'** can be metallic and/or ceramic. For example, the fixation element **230** can be made from titanium, stainless steel, an alloy of titanium, and/or an alloy of cobalt-chromium, or a biocompatible ceramic. In some embodiments, the metallic fixation element **230** can be coated with a coating that promotes bone in-growth. An example of such coating material is a porous metallic coating ADAPTIS™ by Wright Medical Technology.

[0058] In some embodiments, the glenoid implant **200** further comprises one or more fixation features **240** (not shown), like the fixation features **140** described above in connection with the glenoid implant **100**, including all of the variations and options.

[0059] During the surgical procedure for implanting the glenoid implant **200**, after the glenoid is prepared to form a concave surface for receiving the glenoid implant **200**, a pilot hole of an appropriate diameter is drilled into the glenoid for each of the fixation elements **230**, **230'** so that the screw threads **233**, **233'** can tap into the pilot hole and allow the fixation elements **230**, **230'** to be threaded into the corresponding pilot hole. Then, with the distal ends **232**, **232'** of the fixation elements **230**, **230'** facing toward the corresponding pilot hole in the glenoid, the fixation elements **230**, **230'** are threaded into the pilot holes until the proximal ends **231**, **231'** of the fixation elements are flush with the surface of the glenoid.

[0060] When using the embodiment of the fixation elements **230**, **230'** whose longitudinally-extending recesses **235**, **235'** are close-ended, a guide pin can be inserted into the bottom of each of the pilot holes at the center of the pilot holes. Then, the fixation

elements **230, 230'** are placed over the guide pins using the guide holes **238, 238'** one at a time so that the distal ends **232, 232'** of the fixation elements **230, 230'** are facing toward the pilot holes in the glenoid. Each of the fixation elements **230, 230'** are then slid down their corresponding guide pin until the distal ends **232, 232'** of the fixation elements **230, 230'** reach their respective pilot hole. Then the fixation elements **230, 230'** are threaded into the pilot holes until the proximal ends **231, 231'** of the fixation elements are flush with the surface of the glenoid.

[0061] At some point during these steps, before the implant body **210** can be installed, holes are drilled into the glenoid for receiving the one or more fixation features **240**. Next, the implant body **210** is installed by aligning the protrusions **220, 220'** with the recesses **235, 235'** in the fixation elements **230, 230'** and aligning the one or more fixation features **240** with the corresponding holes or slots prepared in the glenoid then pushing the protrusions **220, 220'** into the recesses **235, 235'** until the snap-fitting engagement is achieved.

[0062] In some embodiments, the glenoid implant **200** can be offered in a number of different sizes for the implant body **210** but share the same spacing between the two protrusions **220, 220'**. Then, glenoid implants **200** having different size implant body **210** can be tried on a given glenoid by preparing one pair of holes for receiving the corresponding fixation elements **230, 230'**.

[0063] In some situations where an RSA (reverse shoulder arthroplasty) baseplate is to be placed over the glenoid implant **200**, depending on the particular structure and configuration of the RSA baseplate, the glenoid implant **200** can be configured to have both fixation elements **230, 230'** or just one as appropriate. For example, an embodiment for use with the RSA baseplate in Stryker's ReUnion RSA system where only the inferior half of the glenoid is reamed to receive the RSA baseplate, the glenoid implant **200** can be configured to have only the superiorly positioned fixation element **230'** because the bottom inferior half of the glenoid implant **200** would be fixed by the bone screws that secure the RSA baseplate by traversing through the implant body **210** and into the underlying glenoid bone.

[0064] In some embodiments, the surgeon can trial off of the fixation elements **230, 230'** that are placed in the glenoid and offer a biased insert to tweak anteversion.

[0065] The glenoid implants of the present disclosure are designed to provide many improved characteristics over the conventional baseplate designs. Some of the benefits include, but not limited to: superior fixation strength; low cost; revisable with little to no bone loss; no baseplate, which lessens the stiffness of the implant and potentially provide clinical

benefit; revisable from TSA (total shoulder arthroplasty) to RSA. The glenoid implants of the present disclosure also should exhibit reduced stiffness that is below any metal backed glenoid implants, which is expected to provide improved primary fixation to the glenoid and extend the life of the implant.

[0066] Although the devices, kits, systems, and methods have been described in terms of exemplary embodiments, they are not limited thereto. Rather, the appended claims should be construed broadly, to include other variants and embodiments of the devices, kits, systems, and methods, which may be made by those skilled in the art without departing from the scope and range of equivalents of the devices, kits, systems, and methods.

We claim:

1. A glenoid implant for implantation in a glenoid, the implant comprising:
  - an articular body comprising an articulation surface and an anchoring surface on opposite side of the articular body;
  - at least one protrusion integrally formed with the articular body and extending from the anchoring surface; and
  - a fixation element provided for each of the at least one protrusion, wherein each fixation element comprising:
    - a proximal end, a distal end, a longitudinally-extending recess extending distally from the proximal end, and a screw-threaded external surface,
    - wherein the at least one protrusion and the corresponding fixation element are configured for snap-fitting engagement when the at least one protrusion is inserted into the longitudinally-extending recess of the fixation element.
2. The glenoid implant of Claim 1, wherein the longitudinally-extending recess is a close-ended recess.
3. The glenoid implant of Claim 1, wherein each of the at least one protrusion comprises one or more substantially radially extending tabs provided on exterior surface of the protrusion and the longitudinally-extending recess in each of the at least one fixation element comprises an annular groove, wherein the one or more substantially radially extending tabs and the annular groove form the snap-fitting engagement.
4. The glenoid implant of Claim 3, wherein each of the at least one protrusion defines a longitudinal axis and the corresponding one or more substantially radially extending tabs extend toward the anchoring surface so that a leading surface of the one or more substantially radially extending tabs form an acute angle with the longitudinal axis toward the anchoring surface.
5. The glenoid implant of Claim 4, wherein the close-ended recess comprises a sidewall and the annular groove is cut into the sidewall, wherein the annular groove comprises a distal face and a proximal face, that corresponds to the leading surface and the distal face form an angle with the longitudinal axis toward the anchoring surface that is substantially the acute angle when the at least one protrusion is in snap-fitting engagement with the fixation element.
6. The glenoid implant of Claim 1, comprising one protrusion and one fixation element.

7. The glenoid implant of Claim 1, wherein the fixation element and the articular body comprises different materials.
8. The glenoid implant of Claim 7, wherein the fixation element is formed of a material having higher Young's modulus than that of the articular body.
9. The glenoid implant of Claim 8, wherein the articular body is made of a high modulus polymer.
10. The glenoid implant of Claim 9, wherein the polymer is ultra high molecular weight (UHMW) polyethylene.
11. The glenoid implant of Claim 8, wherein the fixation element is formed of a metal alloy or biocompatible ceramic.
12. The glenoid implant of Claim 1, further comprising one or more fixation features extending from the anchoring surface configured to prevent rotation of the articular body with respect to the glenoid when the glenoid implant is implanted in the glenoid.
13. The glenoid implant of Claim 12, wherein the one or more fixation features extending from the anchoring surface can comprise a post, a finned anchor, or a keel.
14. The glenoid implant of Claim 12, wherein each of the one or more fixation features is a metallic post that is co-molded with the articular body.
15. The glenoid implant of Claim 3, wherein each of the at least one protrusion has a split collet structure.
16. The glenoid implant of Claim 1, wherein one end of the articular body is superior end that is dimensioned to be situated over superior side of the glenoid, and another end of the articular body is inferior end that is dimensioned to be situated over inferior side of the glenoid.
17. The glenoid implant of Claim 16, wherein the at least one protrusion comprises two protrusions, one located near the superior end of the articular body and the other one located near the inferior end of the articular body.
18. The glenoid implant of Claim 16, wherein the articular body has just one protrusion located near the superior end of the articular body.
19. The glenoid implant of Claim 1, wherein the fixation element has an outer diameter that is between 5 - 25 mm, inclusive.

20. The glenoid implant of Claim 19, wherein the fixation element has an outer diameter that is between 6.5 – 20 mm, inclusive.
21. The glenoid implant of Claim 19, wherein the fixation element has an outer diameter that is between 6.5 – 15 mm, inclusive.
22. The glenoid implant of Claim 19, wherein the fixation element has an outer diameter that is between 9 – 15 mm, inclusive.
23. A glenoid implant comprising:  
an articular body comprising an articulation surface and an anchoring surface on opposite side of the articular body;  
two protrusions that are integrally formed with the articular body and extending from the anchoring surface; and  
one fixation element provided for each of the two protrusions, wherein each fixation element comprising:  
a proximal end, a distal end, a longitudinally-extending recess extending distally from the proximal end, and a screw-threaded external surface,  
wherein the two protrusions and the corresponding fixation element are configured for snap-fitting engagement when the two protrusions are inserted into the close-ended recess of the corresponding fixation element.
24. The glenoid implant of Claim 23, wherein the longitudinally-extending recess is a close-ended recess.
25. The glenoid implant of Claim 23, wherein each of the two protrusions comprises one or more substantially radially extending tabs provided on exterior surface of the protrusion and the longitudinally-extending recess in each fixation element comprises an annular groove, wherein the one or more substantially radially extending tabs and the annular groove form the snap-fitting engagement.
26. The glenoid implant of Claim 23, wherein each of the two protrusions defines a longitudinal axis and the corresponding one or more substantially radially extending tabs extend toward the anchoring surface so that a leading surface of the one or more substantially radially extending tabs form an acute angle with the longitudinal axis toward the anchoring surface.
27. The glenoid implant of Claim 23, wherein the longitudinally-extending recess in each fixation element comprises a sidewall and the annular groove is cut into the sidewall, wherein

the annular groove comprises a distal face that corresponds to the leading surface, and the distal face form an angle with the longitudinal axis toward the anchoring surface that is substantially the acute angle when the two protrusion are in snap-fitting engagement with the corresponding fixation elements.

28. The glenoid implant of Claim 23, wherein the fixation elements and the articular body comprises different materials.

29. The glenoid implant of Claim 23, wherein the fixation elements are formed of a material having higher Young's modulus than that of the articular body.

30. The glenoid implant of Claim 23, wherein the articular body is made of a high modulus polymer.

31. The glenoid implant of Claim 30, wherein the polymer is UHMW polyethylene.

32. The glenoid implant of Claim 29, wherein the fixation element is formed of a metal alloy or biocompatible ceramic.

33. The glenoid implant of Claim 23, further comprising one or more fixation features extending from the anchoring surface configured to engage the glenoid when the glenoid implant is implanted in the glenoid.

34. The glenoid implant of Claim 33, wherein the one or more fixation features extending from the anchoring surface can comprise a post, a finned anchor, or a keel.

35. The glenoid implant of Claim 33, wherein each of the one or more fixation features is a metallic post that is co-molded with the articular body.

36. The glenoid implant of Claim 35, wherein the post further comprises one or more bone.

37. The glenoid implant of Claim 23, wherein each of the two protrusions has a split collet structure.

38. The glenoid implant of Claim 23, wherein at least one of the fixation elements has an outer diameter that is between 5 - 25 mm, inclusive.

39. The glenoid implant of Claim 23, wherein at least one of the fixation elements has an outer diameter that is between 6.5 – 20 mm, inclusive.

40. The glenoid implant of Claim 23, wherein at least one of the fixation elements has an outer diameter that is between 6.5 – 15 mm, inclusive.

41. The glenoid implant of Claim 23, wherein at least one of the fixation elements has an outer diameter that is between 9 – 15 mm, inclusive.

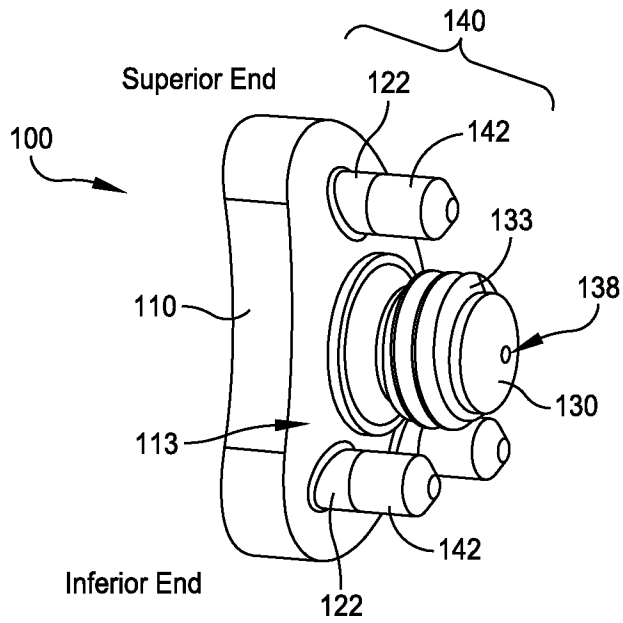

FIG. 1A

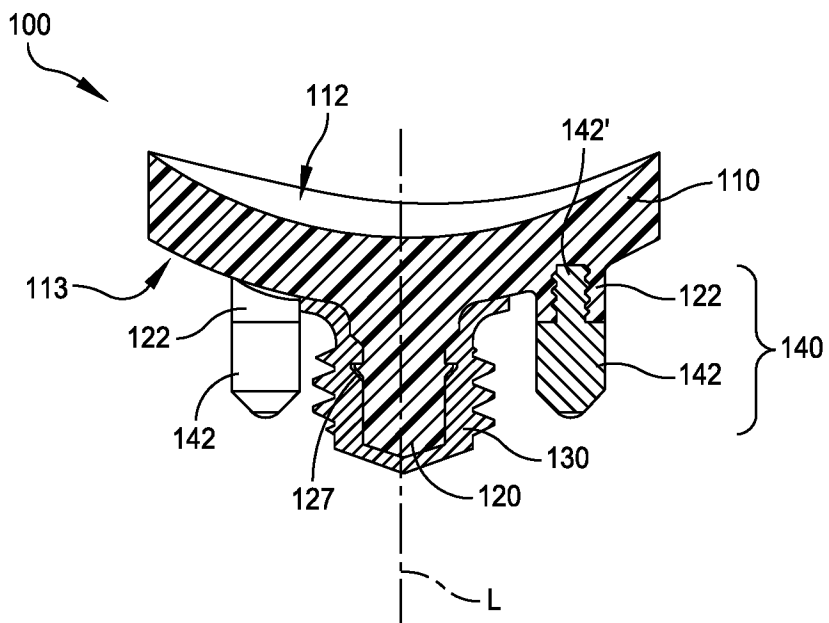

FIG. 1B

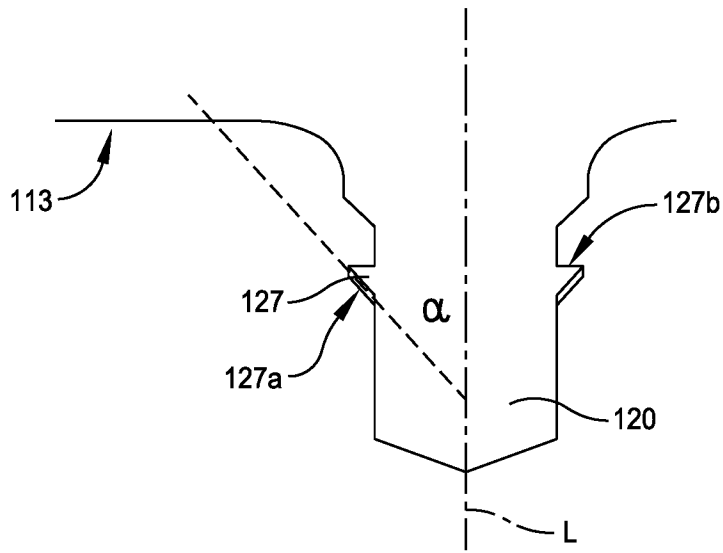

FIG. 1C

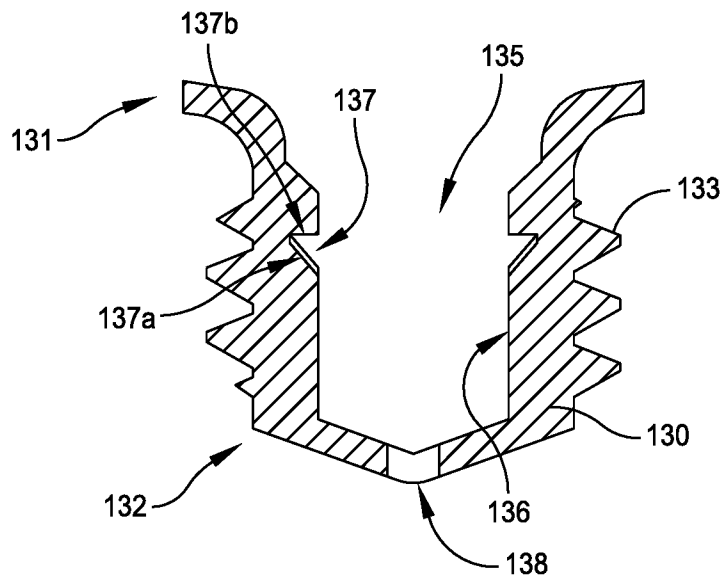

FIG. 1D

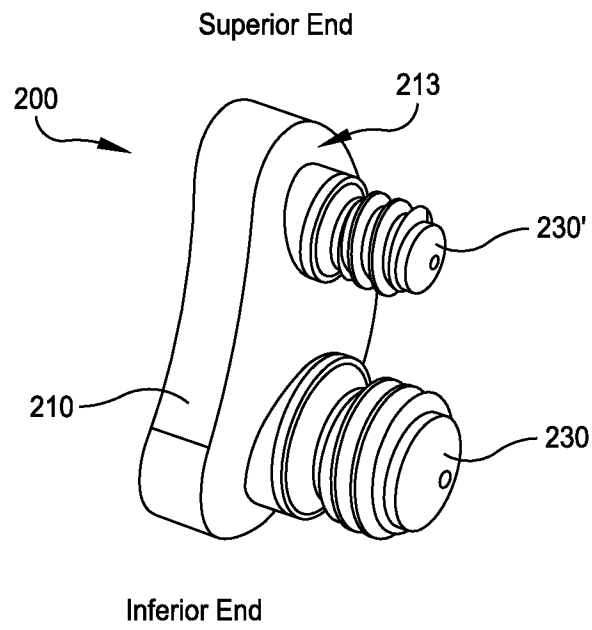

FIG. 2A

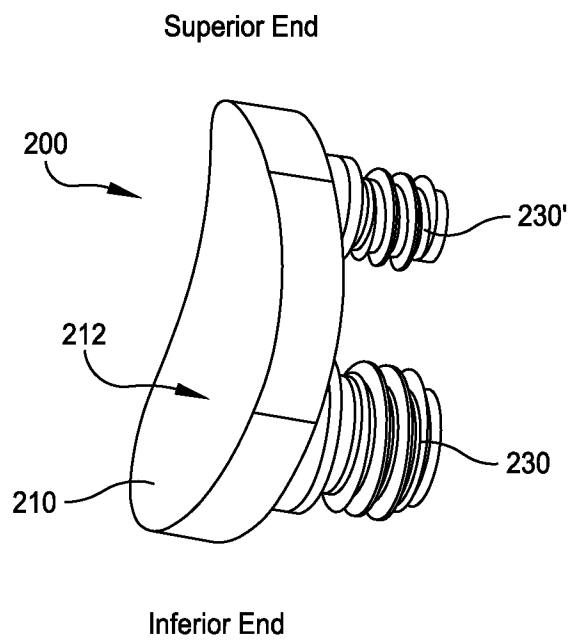

FIG. 2B

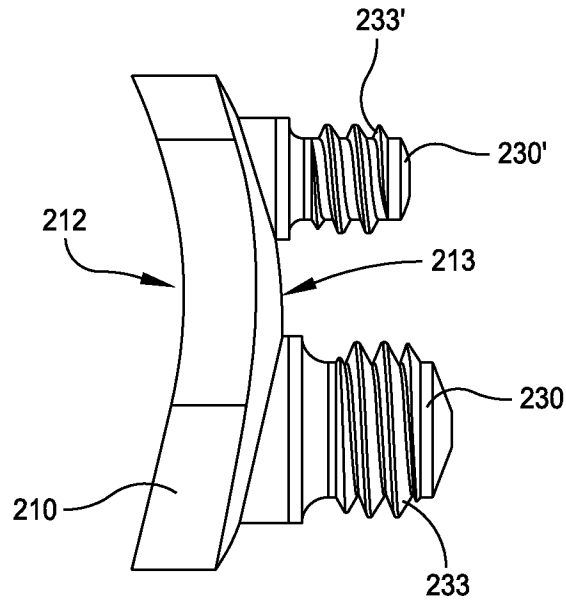

FIG. 2C

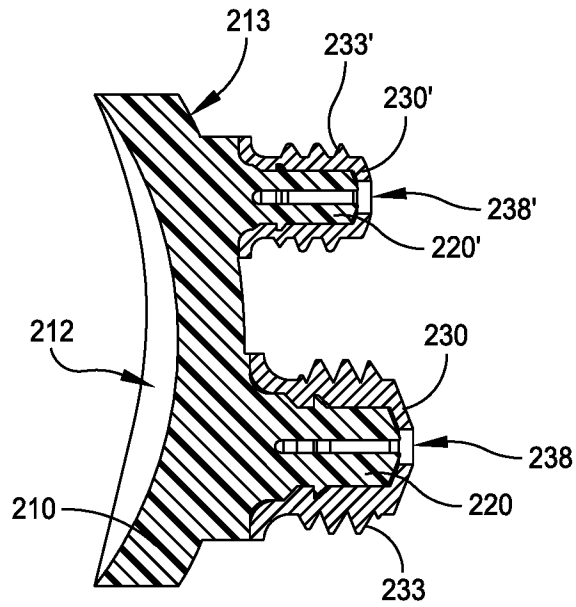

FIG. 2D

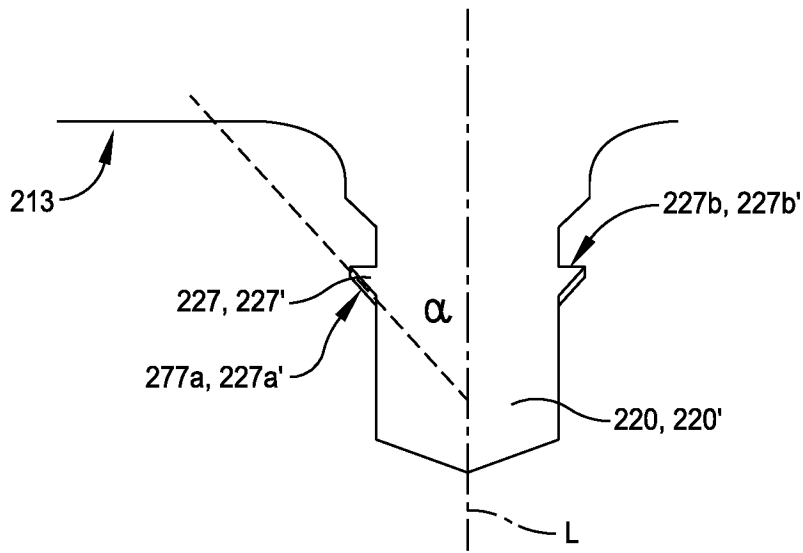

FIG. 2E

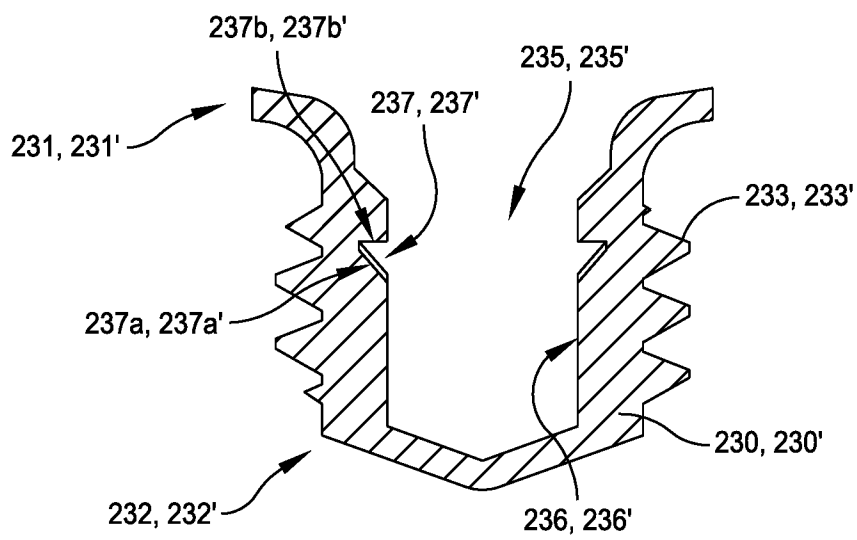

FIG. 2F

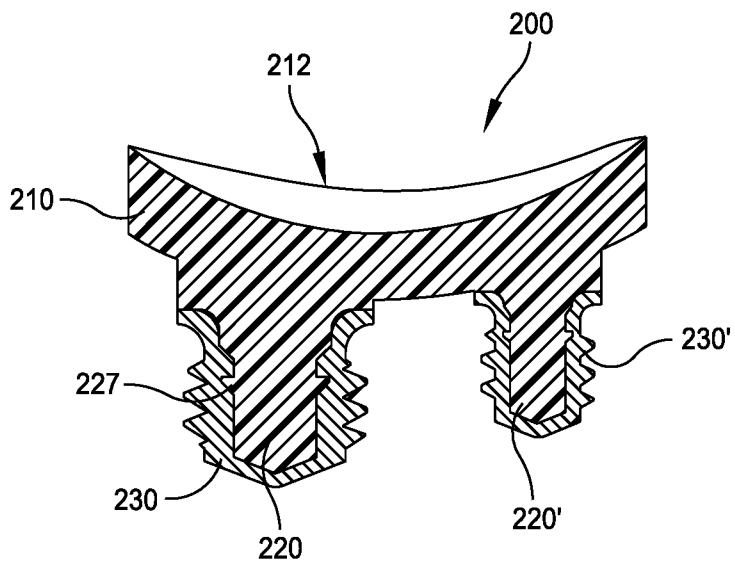

FIG. 2G

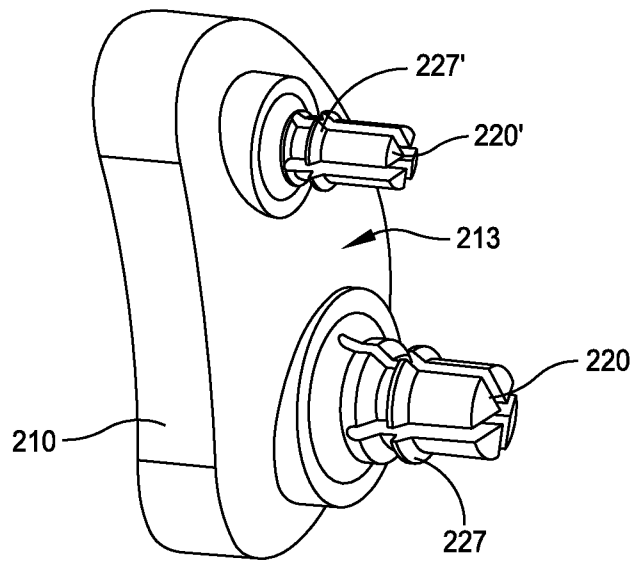

FIG. 2H

## INTERNATIONAL SEARCH REPORT

International application No.

PCT/US 22/34245

## A. CLASSIFICATION OF SUBJECT MATTER

IPC - INV. A61F 2/40 (2022.01)

CPC - INV. A61F 2/4081

According to International Patent Classification (IPC) or to both national classification and IPC

## B. FIELDS SEARCHED

Minimum documentation searched (classification system followed by classification symbols)

See Search History document

Documentation searched other than minimum documentation to the extent that such documents are included in the fields searched

See Search History document

Electronic data base consulted during the international search (name of data base and, where practicable, search terms used)

See Search History document

## C. DOCUMENTS CONSIDERED TO BE RELEVANT

Category*	Citation of document, with indication, where appropriate, of the relevant passages	Relevant to claim No.
X	US 2017/0049574 A1 (ZIMMER GMBH); 23 February 2017 (23.02.2017); entire document, especially Figs. 1-2, 3a; para. [0017], [0020], [0033]-[0036], [0041]-[0042], [0045].	1-2, 6-11, 16-22, 23-24, 28-32, 38-41
X	US 2007/0055380 A1 (BERELSMAN et al.); 08 March 2007 (08.03.2007); entire document, especially Abstract; Fig. 8C, 10A-10B; 12a-12B; 14B-14C; para. [0049], [0067]-[0068], [0070]-[0073], [0076]-[0082].	1, 3-5, 12-15, 23, 25-27, 33-37
A	US 2019/0336293 A1 (BIOMET MANUFACTURING, LLC); 07 November 2019 (07.11.2019); entire document.	1-41
A	WO 2020/154611 A1 (ARTHROSURFACE INCORPORATED); 30 July 2020 (30.07.2020); entire document.	1-41
A	US 2013/0144393 A1 (MUTCHLER et al.); 06 June 2013 (06.06.2013); entire document.	1-40

 Further documents are listed in the continuation of Box C. See patent family annex.

\* Special categories of cited documents:

"A" document defining the general state of the art which is not considered to be of particular relevance

"D" document cited by the applicant in the international application

"E" earlier application or patent but published on or after the international filing date.

"L" document which may throw doubts on priority claim(s) or which is cited to establish the publication date of another citation or other special reason (as specified)

"O" document referring to an oral disclosure, use, exhibition or other means

"P" document published prior to the international filing date but later than the priority date claimed

"T" later document published after the international filing date or priority date and not in conflict with the application but cited to understand the principle or theory underlying the invention

"X" document of particular relevance; the claimed invention cannot be considered novel or cannot be considered to involve an inventive step when the document is taken alone

"Y" document of particular relevance; the claimed invention cannot be considered to involve an inventive step when the document is combined with one or more other such documents, such combination being obvious to a person skilled in the art

"&amp;" document member of the same patent family

Date of the actual completion of the international search

10 August 2022

Date of mailing of the international search report

SEP 23 2022

Name and mailing address of the ISA/US

Mail Stop PCT, Attn: ISA/US, Commissioner for Patents

P.O. Box 1450, Alexandria, Virginia 22313-1450

Facsimile No. 571-273-8300

Authorized officer

Kari Rodriguez

Telephone No. PCT Helpdesk: 571-272-4300