

(19) **DANMARK**

(10) **DK/EP 2531668 T3**



(12) **Oversættelse af
europæisk patentskrift**

Patent- og
Varemærkestyrelsen

-
- (51) Int.Cl.: **E 04 F 19/08 (2006.01)** **E 06 B 5/16 (2006.01)**
- (45) Oversættelsen bekendtgjort den: **2016-08-15**
- (80) Dato for Den Europæiske Patentmyndigheds bekendtgørelse om meddelelse af patentet: **2016-04-27**
- (86) Europæisk ansøgning nr.: **11703123.7**
- (86) Europæisk indleveringsdag: **2011-01-14**
- (87) Den europæiske ansøgnings publiceringsdag: **2012-12-12**
- (86) International ansøgning nr.: **EP2011000145**
- (87) Internationalt publikationsnr.: **WO2011095276**
- (30) Prioritet: **2010-02-05 DE 202010002008 U**
- (84) Designerede stater: **AL AT BE BG CH CY CZ DE DK EE ES FI FR GB GR HR HU IE IS IT LI LT LU LV MC MK MT NL NO PL PT RO RS SE SI SK SM TR**
- (73) Patenthaver: **Knauf Gips KG, Am Bahnhof 7, 97346 Iphofen, Tyskland**
- (72) Opfinder: **KNAUF, Alfons, Jean, Flughafenstr. 10, 64343 Griesheim, Tyskland**
- (74) Fuldmægtig i Danmark: **PATRADE A/S, Fredens Torv 3A, 8000 Århus C, Danmark**
- (54) Benævnelse: **Aflukkelig brandbeskyttelsesåbning for tørmur-byggeri.**
- (56) Fremdragne publikationer:
EP-A2- 1 279 779
NL-C1- 1 006 870
US-B1- 7 650 722

Closable fire protection opening for drywall construction

Description

5 The invention relates to a closable fire protection opening for dry construction, comprising a panel with an opening and comprising a cover for covering the opening, wherein the panel has an opening edge which delimits the opening and the cover has a cover edge, and also comprising a fire protection cover. See for example NL 1006 870 C1, EP 1 279 779 A2, US 7 650 722 B1.

10

Dry construction systems permit the production of structures for interior construction, for example for the fabrication of walls and ceilings. Here, industrial semi-finished products such as gypsum plaster panels and metal profiles are used in a dry construction process. In this way, it is possible for in particular non-load-bearing internal walls, partitions and ceiling constructions, such as suspended ceilings, to be produced inexpensively and quickly. Such constructions often contain installations, for example electrical, ventilation and sanitary installations. These are concealed in the dry construction system after the construction is completed. To nevertheless be able to reach the installations for maintenance and repair purposes, inspection openings are known which are provided in a wall or ceiling and which make it possible to view and access the interior of the construction. Said inspection openings usually have a cover which is connected via a hinge to a frame. If it is necessary to meet fire protection requirements, fire protection openings are provided instead of the inspection openings. Known fire protection openings have an inspection opening as described above, wherein the inspection opening is provided with an additional fire protection cover which covers the opening in addition to the flap.

15

20

25

Said fire protection openings of flap-type design have the disadvantage that they are complex to produce and are therefore expensive. They also have a relatively high weight.

30

It is the object of the invention to develop a closable fire protection opening which is simple and inexpensive to produce and which has a low weight.

35

Said object is achieved by means of the features of Claim 1. The subclaims relate to advantageous embodiments.

To achieve the object, a form fit is produced between the opening edge and the cover edge, in such a way that the cover is held in the opening when in the mounted state. Furthermore, the fire protection cover rests on a frame assigned to the panel. The fire protection cover closes off the opening in addition to the cover, such that the covers are arranged in series and form an obstruction for smoke gases. As a result of the form fit, the cover is held in a self-acting manner in the opening, wherein no additional retaining elements are required. In particular if the fire protection opening is used in a ceiling, the cover is retained in a self-acting manner in the opening owing to the force of gravity. Since no additional retaining elements or the like are required, the fire protection opening has only very few components, specifically in the simplest embodiment, substantially only the panel with frame, the cover and the fire protection cover. An additional stiffening frame for stiffening the fire protection opening and for holding hinges and fastening elements for the cover can be dispensed with. In this way, the fire protection opening is particularly simple and inexpensive to produce and has a particularly low weight. The form fit is preferably generated solely as a result of the shaping of the panel and cover, such that additional form-fit elements can be dispensed with. A further advantage of the closable fire protection opening according to the invention is its small structural height. The structural height of the fire protection opening is defined by the structural height of the panel, frame and fire protection cover mounted thereon. In this way, the fire protection opening can be used even where there is only a very limited amount of installation space available.

The panel and the cover may each have a first main side and a second main side, and the opening edge may be formed such that the cross-sectional area of the opening on the first main side is smaller than the cross-sectional area of the second main side. In this embodiment, the cover edge is formed such that the cross-sectional area of the cover on the first main side is smaller than the cross-sectional area on the second main side. It is preferably the case that the cross-sectional area of the first main side of the opening corresponds to the cross-sectional area of the first main side of the cover, and that the cross-sectional area of the second main side of the opening corresponds to the cross-sectional area of the second main side of the cover. To mount the cover, said cover is placed into the opening proceeding from the room assigned to the second main side of the opening. Owing to the smaller cross section of the opening on the first main side, the cover cannot fall through the opening, and in the case of a ceiling construction, is held in a self-acting manner in the opening owing to the force of gravity.

The opening edge and the cover edge may be formed congruently with respect to one another. This yields a particularly secure form fit, such that the cover is firstly held securely in the opening and secondly does not become jammed in the opening. It is also advantageous for only a small gap to be formed between the panel and cover.

The opening edge and the cover edge may be profiled, wherein the profiling is such that the opening edge and the cover edge at least partially overlap one another as viewed in cross section. For this purpose, at least one or more lugs may be formed from the opening edge and/or from the cover edge. One lug is preferably of encircling form. The lugs may be provided with different radii. This results in a large overlap and therefore secure hold for the cover. In another embodiment, the opening edge and the cover edge may be in the form of bevels. Such a form is particularly simple to produce. It is also conceivable for in each case at least one step to be formed from the opening edge and from the cover edge. Here, the cover latches in a particularly defined manner into the opening and cannot become jammed. The opening edge and cover edge may also be formed such that a plurality or all of the abovementioned design elements are combined.

The above-described embodiments each have the advantage that the cover terminates flush with the panel and the cover in particular does not protrude beyond one of the two main sides of the panel. Furthermore, the joint formed by the opening edge and the cover edge is particularly impervious to smoke in this embodiment because a type of labyrinth is formed.

The opening and the cover may be of triangular, rectangular or polygonal form. Triangular covers are particularly easy to handle, and concealed installations can be reached particularly easily through rectangular openings. In the case of rectangular openings and covers, in particular of non-square form, the cover can be easily removed through the opening.

Owing to the rectangular, triangular or polygonal basic shape of the opening of the panel and of the cover, straight portions may be provided, and the straight portions of the panel and/or cover may be connected via rounded portions. If brittle materials are used, there is an increased fracture propensity at a sharp-edged portion, in particular where a straight portion and an acute angle meet. To reduce the fracture propensity, the straight portions are connected to one another via rounded portions. Said rounded portions are provided with a radius. The radius is

preferably between 1 cm and 10 cm. Radii in this range reduce the fracture propensity without reducing the size of the opening to too great an extent.

5 The opening and the cover may each have a circular or an oval basic shape. In the case of a circular design, a situation where straight portions meet at an acute angle is avoided, which is relevant in particular if brittle materials such as gypsum are used. These have a greatly increased fracture propensity in particular at sharp-edged corners.

10 The height of the frame is preferably selected such that, when the fire protection cover is in the mounted state, an assembly space is formed between the panel and the fire protection cover. To close off the fire protection opening, it is necessary for firstly the fire protection cover to be mounted on the frame. As a result of the height of the frame, an assembly space remains between the panel, frame
15 and fire protection cover after the fire protection cover has been mounted, such that the cover can be inserted into the space through the opening and subsequently placed in the opening. For this purpose, it is necessary for the height of the assembly space to correspond at least to the height of the cover. If the height of the assembly space corresponds to twice the height of the cover, handling is
20 made easier during the mounting of the cover. For this embodiment, square or oval cover and opening shapes are particularly suitable because, in these embodiments, the cover can be moved through the opening.

The frame may be arranged on the panel so as to be spaced apart from the opening: That is to say, a spacing is formed between the opening edge and the inner
25 side of the frame, such that the cross-sectional area delimited by the inner side of the frame is larger than the cross-sectional area delimited by the opening. Here, the cross-sectional area delimited by the inner side of the frame should at least be selected such that a cover inserted through the opening can be rotated in the
30 assembly space with the fire protection cover mounted. The clear spacing between the mutually opposite inner sides of the frame preferably corresponds at least to the longest diagonal extent of the cover. In this embodiment, the space delimited by the panel, the frame and the fire protection cover is further increased in size by virtue of the fact that the space extends parallel to the plane of
35 the panel. In this way, it is possible for a cover that has been inserted through the opening to be rotated in the available space despite the mounted fire protection cover, such that the cover can be oriented into the correct position with respect to the opening.

The fire protection cover may be of multi-part form. In this way, the fire protection cover is easier to handle and can be more easily removed from the frame and set down on both sides of the opening in order to be able to reach the concealed installation through the opening.

The fire protection cover may have two cover parts which are arranged adjacent to one another on the frame and which at least partially overlap along the contact joint. In this way, the fire protection cover is particularly easy to handle and smoke-tight. The sealing action may be further improved through the insertion of a fire protection seal as described above.

The fire protection cover may be of multi-layer form. In this embodiment, the overlapping contact joint is particularly simple to produce by virtue of the panels which form the cover parts having different dimensions, such that a panel of one cover part overlaps another panel of the other cover part. It is also conceivable for the plates to be joined to one another with an offset. A multi-layer fire protection cover, formed for example from two or more gypsum plaster panels, furthermore offers increased fire protection in relation to a single-layer fire protection cover.

The frame, cover and fire protection cover are preferably composed of non-combustible materials, in particular of gypsum plaster panels, gypsum fiber panels, mineral fiber panels and/or of cement materials and/or metallic materials, in particular in sheet-metal form. Such materials are proven in the field of dry construction and have advantageous properties with regard to fire protection. Surprisingly, panels and covers composed of gypsum or cement materials have adequate stability despite their high brittleness, such that the cover can be removed and re-mounted multiple times. Mineral fiber panels are non-combustible and have advantageous sound-absorbing properties. Mineral fiber panels are therefore suitable in particular for ceiling constructions. In particular, the cover and/or the fire protection cover may have in each case one or more panels of the abovementioned type arranged one on top of the other. The cover can thus be of multi-layer form.

35

Brief description of the drawings

A number of exemplary embodiments of the closable fire protection opening according to the invention will be explained in more detail below on the basis of the figures, in which, in each case schematically:

- 5 figure 1 shows the fire protection cover with frame and bead, cover and fire protection cover in an exploded illustration;
- figure 2 shows the fire protection cover as per figure 1 in cross section;
- 10 figure 3 shows the fire protection cover as per figure 1 in a three-dimensional illustration;
- figure 4 shows the fire protection cover as per figure 1 in plan view.

15 Description of the figures

Figure 1 shows a closable fire protection opening 1 for dry construction. In this embodiment, the fire protection opening 1 is designed for use in a ceiling construction, in this case a suspended ceiling. The panel 2 is provided with an opening 3 in which a cover 4 for covering the opening 3 is arranged in a removable manner. The cover 4 is formed congruently with respect to the opening 3, such that there is only a small encircling joint between the panel 2 and cover 4. The cover 4 is held with a form fit in the opening 3, wherein the form fit is such that the cover 4 is held in the panel 2 under the force of gravity alone. The fire protection cover 7 rests with a form fit on a frame 8, wherein the frame 8 is fastened to the second main side 10 of the panel 2 and surrounds the opening 3. The frame 8 is composed of strips of a non-combustible material which are arranged in multiple layers in an encircling manner around the opening 3 and which are connected cohesively to the panel 2. It is however also conceivable for the strips to be screwed on. Here, strips are placed one on top of the other in such numbers that the height of the frame 8 corresponds to three times the height of the cover 4. When the fire protection cover 7 is mounted, an assembly space 17 is formed, the height of which corresponds to twice the height of the cover 4. Furthermore, the frame 8 is fastened to the panel 2 so as to be spaced apart from the opening 3. As a result, the assembly space is increased in size parallel to the plane of the panel 2. As a result, with the fire protection cover 7 in the mounted state, the cover 4 can be passed through the opening 3 and subsequently rotated, such that the cover 4 can be aligned relative to the opening 3. The fire protection cover 7

has, at its outer encircling edge, a projecting length such that the fire protection cover 7 partially overlaps the frame 8 and is partially sunken between the frame 8 in the direction of the opening 3. The top side of the frame 8 is provided with a fire protection seal which, in the event of a fire, swells up and seals off the gap between the fire protection cover 7 and the frame 8. In this embodiment, the panel 2, cover 4, frame 8 and fire protection cover 7 are composed of mineral fiber panels. In other embodiments, the panel 2, cover 4, fire protection cover 7 and frame 8 may also be composed of other non-combustible materials such as gypsum plaster panels, gypsum fiber panels and/or cement materials and/or mineral fiber panels and/or of metallic materials, in particular in sheet-metal form. Combinations of the abovementioned materials are also conceivable. In the illustration, the cover 4 is rectangular. In other embodiments, the cover 4 is of circular or triangular form. Owing to the rectangular opening 3 of the panel 2 and of the cover 4, straight portions 12 are provided, and the straight portions 12 of the panel 2 and/or cover 4 are connected via rounded portions 13. The rounded portions 13 form a radius which, depending on the size of the opening 3, is between 1 cm and 10 cm. The fire protection cover 7 is of multi-part form and is composed of two cover parts 14, 15 which are arranged adjacent to one another on the frame 6 and which partially overlap one another along a contact joint 16. A fire protection seal is arranged in the contact joint. In the contact joint 16 there is arranged a fire protection seal. Furthermore, the cover parts 14, 15 of the fire protection cover 7 are of multi-layer form. In this embodiment, the cover parts 14, 15 are of two-layer form, wherein the individual panels are dimensioned so as to yield the projecting lengths at the outer edges of the fire protection cover 5 and between the cover parts 14, 15.

Figure 2 shows, in section, the fire protection opening 1 described in the figure. The panel 2 and the cover 4 each have a first main side 9 and a second main side 10 and the panel 2 has an opening edge 5 which delimits the opening 3 the cover 4 has a cover edge 6, wherein the opening edge 5 is formed such that the cross-sectional area of the opening 3 on the first main side 9 is smaller than the cross-sectional area of the second main side 10.

Furthermore, the cover edge 6 is formed such that the cross-sectional area of the cover 4 on the first main side 9 is larger than the cross-sectional area on the second main side 10. The first main side 9 points in the direction of the room and the second main side 10 points in the direction of the ceiling, or in the direction of the fire protection cover 7. The opening edge 5 and the cover edge 6 are formed congruently with respect to one another and profiled, wherein the opening edge 5

and the cover edge 6 at least partially overlap one another as viewed in cross section. For this purpose, in each case one step 11 is formed from the opening edge 5 and from the cover edge 6.

- 5 Figure 3 shows a three-dimensional illustration of the fire protection opening 1 described in figure 1. Figure 4 shows a plan view of the fire protection opening 1 described in figure 1.

List of reference numerals

- 1 Fire protection opening
- 2 Panel
- 3 Opening
- 4 Cover
- 5 Opening edge
- 6 Cover edge
- 7 Fire protection cover
- 8 Frame
- 9 First main side
- 10 Second main side
- 11 Step
- 12 Straight portion
- 13 Rounded portion
- 14 Cover part
- 15 Cover part
- 16 Contact joint
- 17 Assembly space

PATENTKRAV

1. Aflukkelig brandbeskyttelsesåbning (1) for tørmur-byggeri, omfattende en plade (2) med en åbning (3) og et dæksel (4) til afdækning af åbningen (3), hvorved pladen (2) omfatter en åbningskant (5), der afgrænser åbningen (3), og dækslet omfatter en dækselkant (6), såvel som et brandbeskyttelsesdæksel (7),
- 5
- k e n d e t e g n e t v e d**, at der mellem åbningskanten (5) og dækselkanten (6) er tilvejebragt en formfølgning på en sådan måde, at dækslet (4) i monteret tilstand fastholdes i åbningen (3), og at brandbeskyttelsesdækslet (7) ligger an mod en ramme (8), som er knyttet til pladen (2), hvorved rammens (8) højde er valgt således, at der efter pålægning af brandbeskyttelsesdæksel (7) fremkommer et monteringsrum (17) mellem pladen (2) og brandbeskyttelsesdækslet (7), hvorved monteringsrummets (17) højde i det mindste svarer til dækslets (4) højde.
- 10
- 15
2. Brandbeskyttelsesåbning ifølge krav 1,
- k e n d e t e g n e t v e d**, at pladen (2) og dækslet (4) hver for sig omfatter en første hovedside (9) og en anden hovedside (10), og at åbningskanten (5) er udformet således, at åbningens (3) tværsnitsareal på den første hovedside (9) er mindre end åbningens (3) tværsnitsareal på den anden hovedside (10).
- 20
3. Brandbeskyttelsesåbning ifølge krav 2,
- k e n d e t e g n e t v e d**, at dækselkanten (6) er udformet således, at dækslets (4) tværsnitsareal på den første hovedside (9) er mindre end dækslets (4) tværsnitsareal på den anden hovedside (10).
- 25
4. Brandbeskyttelsesåbning ifølge krav 3,
- k e n d e t e g n e t v e d**, at åbningens kant (5) og dækselkanten (6) er udformet, så de indbyrdes er kongruente.
- 30
5. Brandbeskyttelsesåbning ifølge et hvilket som helst af kravene 1 til 4,
- k e n d e t e g n e t v e d**, at åbningens kant (5) og dækslets kant (6) er profilerede, hvorved profileringen er udformet således, at åbningskanten (5) og dækselkanten (6) indbyrdes overlapper hinanden, i det mindste i nogle afsnit, set i tværsnit.
- 35
6. Brandbeskyttelsesåbning ifølge krav 5,

k e n d e t e g n e t v e d , at der fra henholdsvis åbningskanten (5) og dækselkanten (6) er dannet i det mindste eet trin (11).

- 5 7. Brandbeskyttelsesåbning ifølge et hvilket som helst af de foregående krav 1 til 6,
k e n d e t e g n e t v e d , at åbningen (3) i pladen (2) og dækslet (4) hver for sig har en grundform, som er trekantet, rektangulær eller polygonal.
- 10 8. Brandbeskyttelsesåbning ifølge et hvilket som helst af kravene 1 til 7,
k e n d e t e g n e t v e d , at der tallet være den rektangulære, trekantede eller polygonale grundform for åbningen (3) pladen (2) og dækslet (4) er tilvejebragt retlinjede afsnit (12), og at pladens (2) og/eller dækslets (4) retlinjede afsnit (12) er forbundet via afrundede afsnit (13).
- 15 9. Brandbeskyttelsesåbning ifølge et hvilket som helst af kravene 1 til 6,
k e n d e t e g n e t v e d , at åbningen (3) og dækslet (4) hver for sig omfatter en cirkulær eller oval grundform.
- 20 10. Brandbeskyttelsesåbning ifølge et hvilket som helst af kravene 1 til 9,
k e n d e t e g n e t v e d , at rammen (8) er anbragt således på pladen (2), at den har en afstand fra åbningen (3).
- 25 11. Brandbeskyttelsesåbning ifølge et hvilket som helst af kravene 1 til 10,
k e n d e t e g n e t v e d , at brandbeskyttelsesdækslet (7) består af flere dele.
- 30 12. Brandbeskyttelsesåbning ifølge krav 11,
k e n d e t e g n e t v e d , at brandbeskyttelsesdækslet (7) omfatter to dækseldele (14, 15), som er anbragt ved siden af hinanden på rammen (8) og indbyrdes overlapper hinanden langs en kontaktfuge (16).
- 35 13. Brandbeskyttelsesåbning ifølge krav 9 eller krav 12,
k e n d e t e g n e t v e d , at brandbeskyttelsesdækslet (7) består af flere lag.
14. Brandbeskyttelsesåbning ifølge et hvilket som helst af kravene 1 til 13,

k e n d e t e g n e t v e d , at pladen (2), dækslet (4) og brandbeskyttelsesdækslet (7) er udført af ikke-brændbare materialer, navnlig af gipsplader, fibergipsplader, mineralfiberplader og/eller af cementplader og/eller af metalmaterialer, navnlig i form af metalplade.

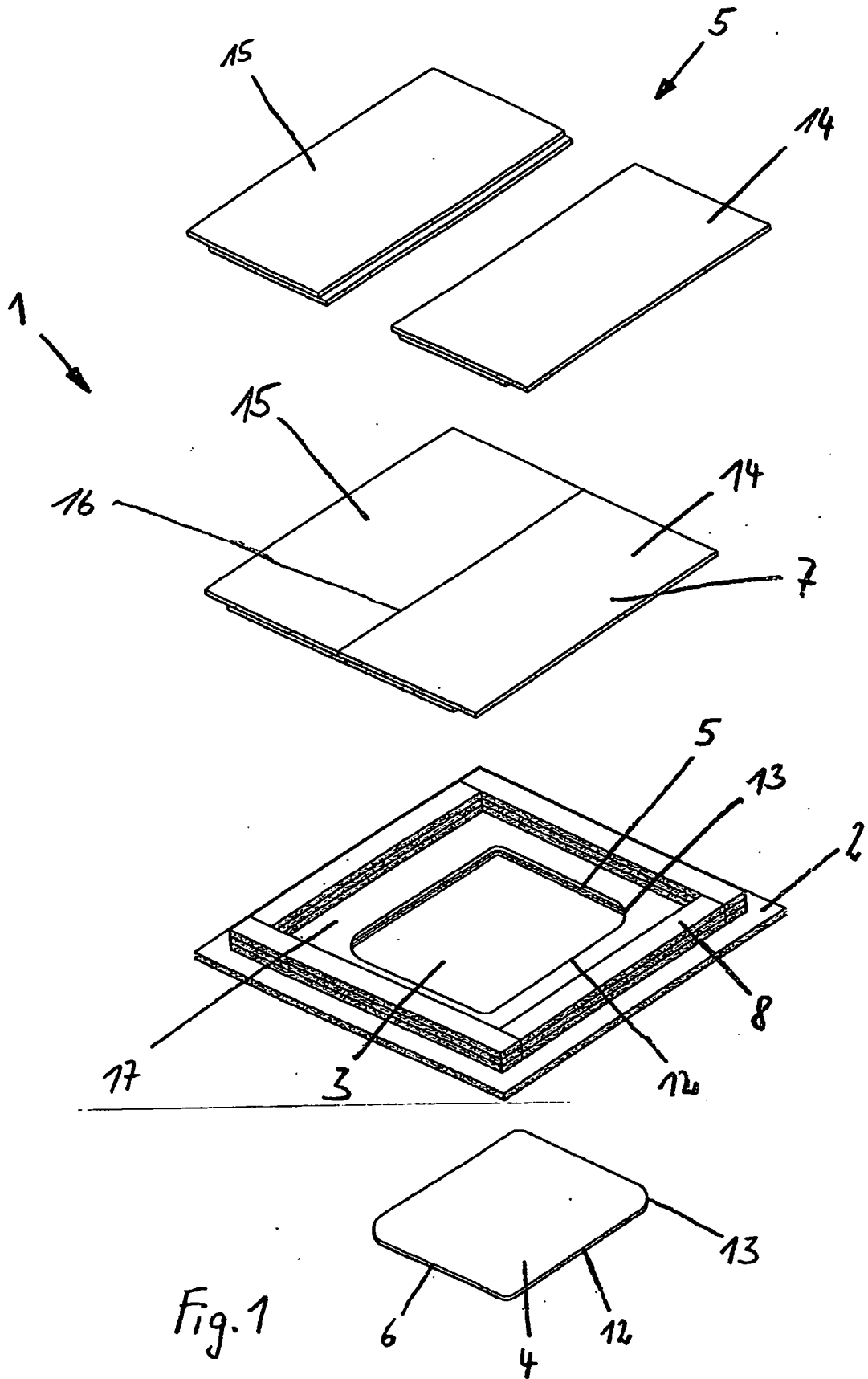

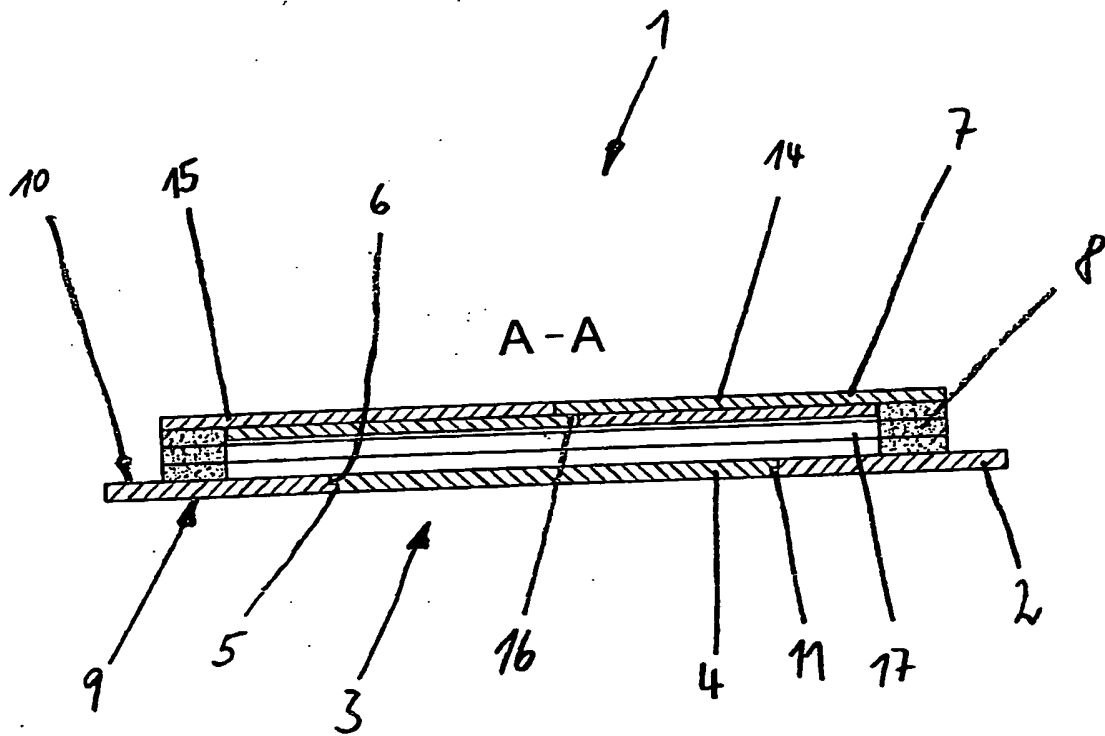

Fig. 2

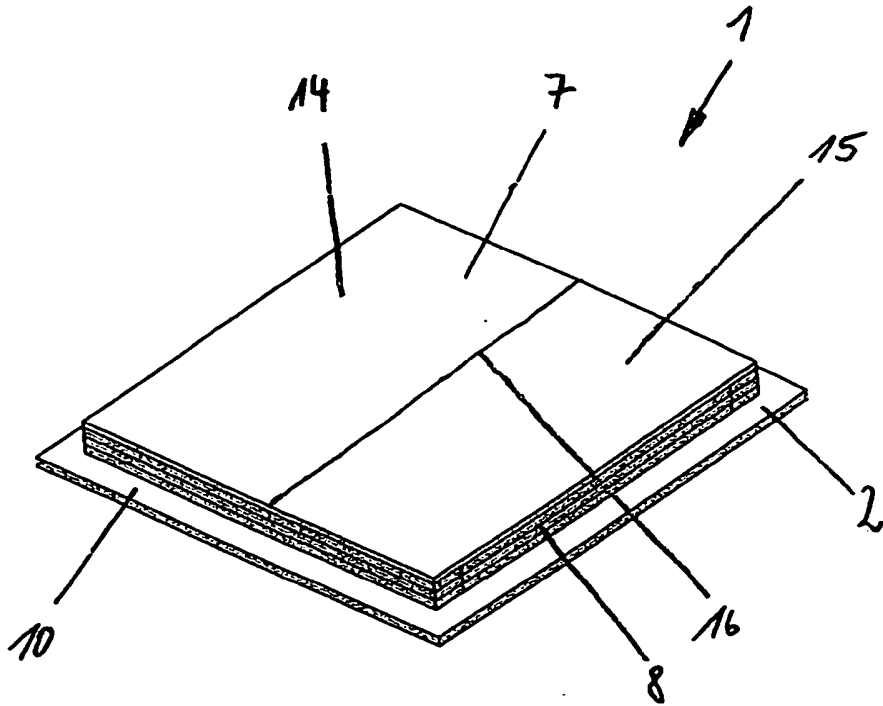

Fig. 3

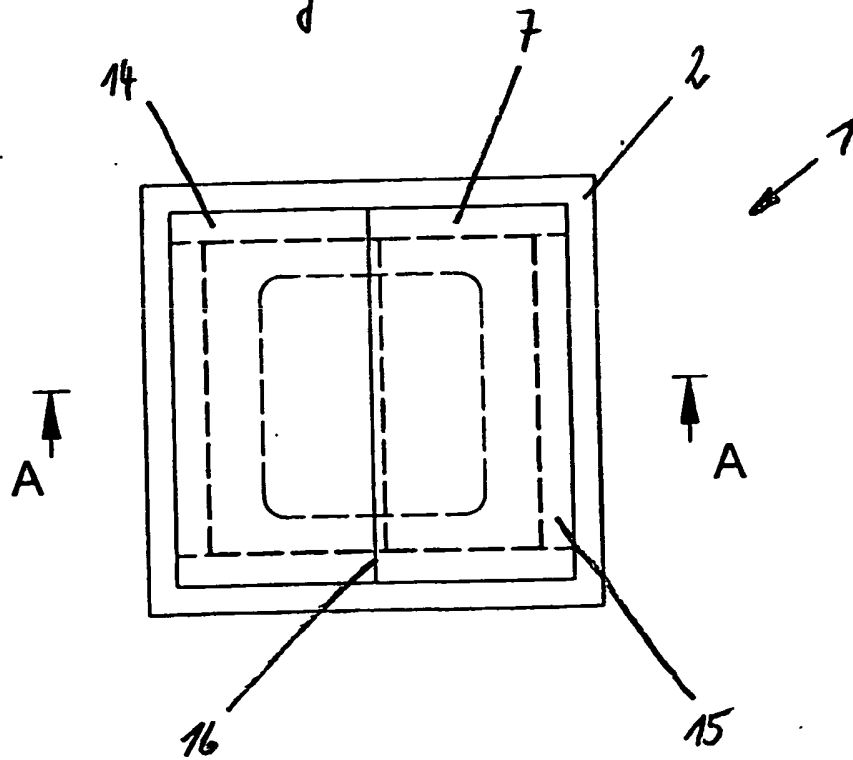

Fig. 4