



(86) Date de dépôt PCT/PCT Filing Date: 1997/11/17
 (87) Date publication PCT/PCT Publication Date: 1998/06/04
 (45) Date de délivrance/Issue Date: 2004/01/06
 (85) Entrée phase nationale/National Entry: 1999/05/26
 (86) N° demande PCT/PCT Application No.: DE 1997/002695
 (87) N° publication PCT/PCT Publication No.: 1998/024137
 (30) Priorité/Priority: 1996/11/28 (196 49 436.2) DE

(51) Cl.Int.⁶/Int.Cl.⁶ H01M 8/04
 (72) Inventeurs/Inventors:
 BETTE, WILLI, DE;
 LERSCH, JOSEF, DE
 (73) Propriétaire/Owner:
 SIEMENS AKTIENGESELLSCHAFT, DE
 (74) Agent: FETHERSTONHAUGH & CO.

(54) Titre : METHODE D'IDENTIFICATION DE FUITES DE GAZ ET UNE INSTALLATION A CELLULES
ELECTROCHIMIQUES

(54) Title: METHOD FOR IDENTIFYING A GAS LEAK, AND A FUEL CELL SYSTEM

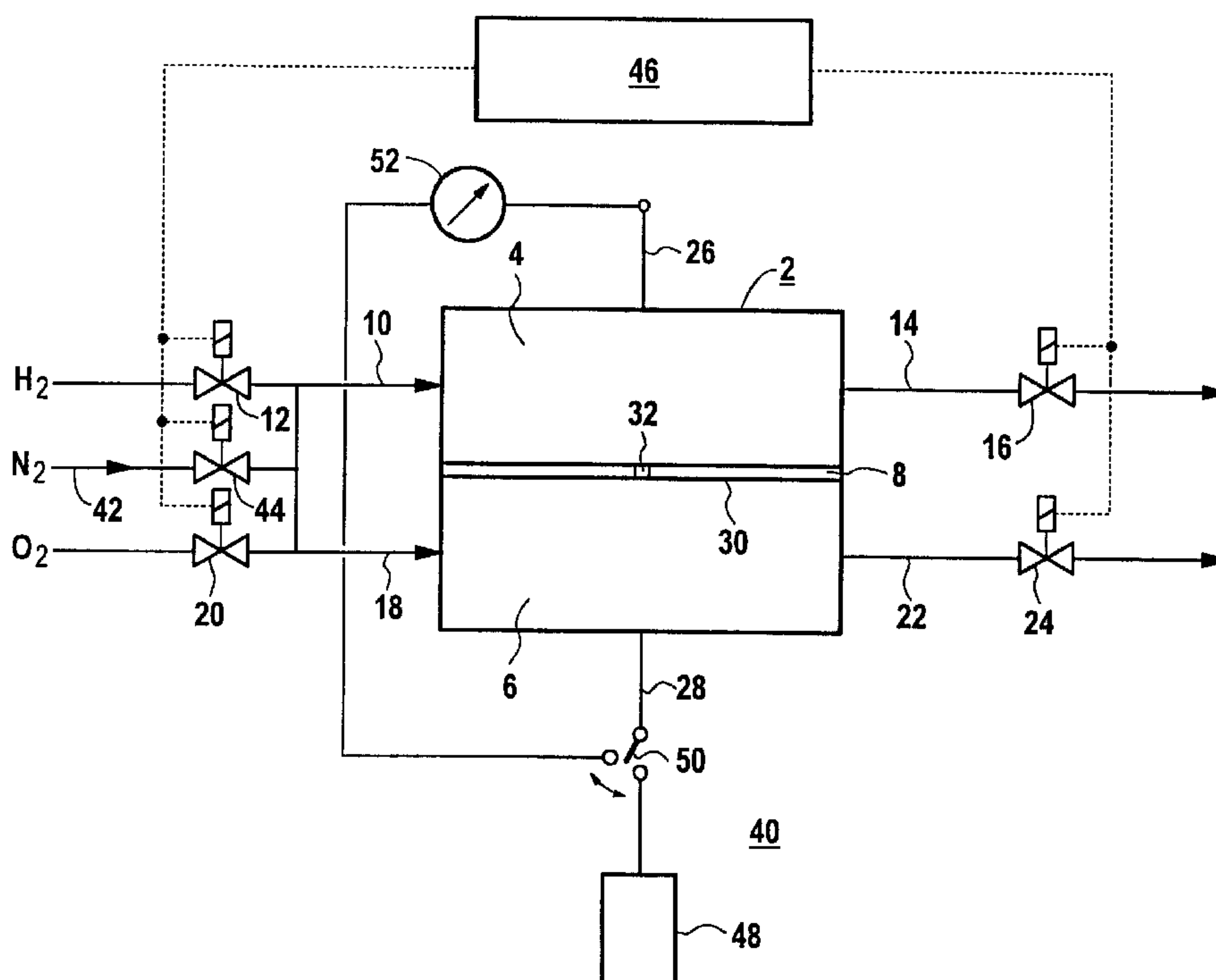

(57) Abrégé/Abstract:

In the case of the present method for identifying a gas leak (32) between the anode and cathode gas areas (4 and 6, respectively) of a PEM fuel cell (2), a cell voltage is detected, and the anode and cathode gas areas (4 and 6, respectively) are purged with nitrogen (N₂) in a first time period, the cathode gas area (6) is filled with oxygen (O₂) and the anode gas area (4) is filled with hydrogen (H₂) in a second time period, and the drop in the cell voltage below a limit value as a function of time is then measured and evaluated. This measure ensures reliable identification of the gas leak (32).

GR 96 P 3979 P

Abstract

Method for identifying a gas leak, and a fuel cell system

In the case of the present method for identifying a gas leak (32) between the anode and cathode gas areas (4 and 6, respectively) of a PEM fuel cell (2), a cell voltage is detected, and the anode and cathode gas areas (4 and 6, respectively) are purged with nitrogen (N_2) in a first time period, the cathode gas area (6) is filled with oxygen (O_2) and the anode gas area (4) is filled with hydrogen (H_2) in a second time period, and the drop in the cell voltage below a limit value as a function of time is then measured and evaluated. This measure ensures reliable identification of the gas leak (32).

FIG 1

GR 96 P 3979 P

Description

Method for identifying a gas leak, and a fuel cell system

5

The invention relates to a method for identifying a gas leak between the anode and cathode gas areas of a PEM fuel cell, and to a fuel cell system for carrying out the method.

10

It is known that, during the electrolysis of water, the water molecules are broken down by electric currents into hydrogen and oxygen. In the fuel cell, this process takes place in the opposite direction. During the electrochemical combination of water and hydrogen to form water, electric current is produced with high efficiency, and to be precise, if pure hydrogen is used as the combustion gas, this is done without any emission of hazardous materials or carbon dioxide. Even with technical combustion gases, such as natural gas or coal gas, and using air or air enriched with O_2 instead of pure oxygen, a fuel cell produces a considerably smaller amount of hazardous materials and less CO_2 than other energy producers which operate with fossil energy sources. The technical implementation of the principle of the fuel cell has led to widely differing solutions, to be precise with different types of electrolytes and with operating temperatures between $80^\circ C$ and $1000^\circ C$. The fuel cells are split into low-, medium- and high-temperature fuel cells depending on their operating temperature and are furthermore respectively distinguished by different technical embodiments.

25
30

In addition to these fundamental advantages, a fuel cell having a solid electrolyte composed of plastic (polymer electrolyte membrane or PEM) has other positive

35

characteristics, such as a low operating temperature (less than or equal to 80°C), a good overload behavior, little voltage degradation, long life, good load and temperature cycling response, and lack of any liquid
5 corrosive electrolyte. Furthermore, it is also suitable for operation with air from the environment, instead of oxygen. All these characteristics make the PEM fuel cell, which can be operated with air, a virtually ideal electrical source, for example for electrical power for
10 motor vehicles, without any emissions.

A fuel cell block which is also called a "stack" in the specialist literature, is, as a rule, composed of a multiplicity of fuel cells stacked on top of each other and of planar construction. Since the fuel cell
15 block cannot be operated on its own, the fuel cell block, an operating section and an associated electronics module are in general combined to form a fuel cell module. The operating section contains the devices for supplying the agents, for example hydrogen
20 (H₂), oxygen (O₂) or air from the environment, for removing the product water, for dissipating heat losses, for moistening the agents, and for extracting the inert gas constituents.

During operation of a PEM fuel cell module, any
25 defect that occurs in an individual PEM fuel cell leads to a disturbance in the operation of the entire PEM fuel cell module. For example, a gas escape from the anode gas area to the cathode gas area of the PEM fuel cell owing to a leak in the membrane electrode unit can lead
30 to a thermal reaction between hydrogen (H₂) and oxygen (O₂) being initiated on the catalyst. Rapid identification of the gas leak between the anode and the cathode gas areas and, following this, identification

GR 96 P 3979 P

- 3 -

of such a defective fuel cell in the fuel cell module, have been found to be problematic.

In the case of a method known from the prior art for identifying a gas leak between the anode and cathode sides of the fuel cell, a pressure difference is produced between these sides, and the rate of change of the pressure difference is evaluated. Pressures are thus measured in this method. This method is an integral measurement over a plurality of fuel cells in the fuel cell module, that is to say it is not possible to identify an individual defective fuel cell in the fuel cell module. Furthermore, the method is unsuitable for identifying small leaks in a fuel cell module, owing to its low sensitivity.

The invention is now based on the object of specifying a method having adequate sensitivity for identifying a gas leak between the anode and cathode gas areas of a PEM fuel cell.

In the case of a method for identifying a gas leak between the anode and cathode gas areas of a PEM fuel cell by detecting the cell voltage U , according to the invention, the anode and cathode gas areas are purged with nitrogen (N_2) in a first time period, the cathode gas area is filled with oxygen (O_2) and the anode gas area is filled with hydrogen (H_2) in a second time period, and the drop in the cell voltage U below a limit value U_G as a function of time is then measured and evaluated.

The cell voltage U which can be evaluated, between the anode and cathode gas areas, is in the region of the no-load voltage of the PEM fuel cell, of about 1 V. With this

cell voltage U which can be evaluated, the method has adequate sensitivity for identifying the gas leak in the PEM fuel cell, thus ensuring technically reliable applicability. Each individual cell can be examined
5 individually using the method. The disadvantage of an integral measurement, where all that can be decided is whether a defective cell is within a group of a plurality of cells, but cannot be located accurately, is in this way avoided. The faster the cell voltage U falls
10 below the limit value U_G the greater is the probability that there is a leak in the fuel cell.

The anode gas area and/or the cathode gas area are/is preferably kept closed during the measurement. No further agents are therefore supplied. Enlargement of
15 any leak which may be present as a consequence of powerful reactions between agents continuously supplied to the fuel cell is prevented.

In particular, the majority of the oxygen (O_2) can be removed from the cathode gas area between the
20 first and the second time periods. All that remains in the cathode gas area is residual oxygen (O_2) which adheres to the cathode. The time interval for the measurement can thus be shortened and, in consequence, any enlargement of the leak owing to powerful chemical
25 reactions which would otherwise occur can essentially be avoided.

In a further refinement, the limit value U_G for the cell voltage U is set to about half the no-load voltage of the PEM fuel cell. Half the no-load voltage
30 is about 0.5 V. If the cell voltage U falls below the limit value U_G within a time period of 15 to 20 s, in particular within 16 s, then it can reliably

20365-3981

- 5 -

be assumed that the fuel cell has a leak. In a serviceable fuel cell without a leak, the cell voltage would take at least 50 s to fall below the limit value U_G . A defective fuel cell can thus clearly be identified using the method.

5 A fuel cell system having a PEM fuel cell has, according to the invention, a controller for carrying out the method, that is to say for supplying the nitrogen and for checking and measuring the cell voltage.

10 In some embodiments, the cathode gas area (6) is filled with oxygen (O_2) for about 1 s, at an absolute pressure of about 2.3 bar, during the second time period.

In some embodiments, the majority of the oxygen (O_2) is removed after the second time period.

15 In some embodiments, the limit value U_G is half the no-load voltage of the PEM fuel cell (2).

In some embodiments, the cell voltage U is measured for 15 to 20 s.

20 In some embodiments, the anode gas area (4) is filled with hydrogen (H_2) for about 0.1 s, at an absolute pressure of about 2.0 bar, during the second time period.

An exemplary embodiment will be explained, with reference to a figure, in order to assist understanding of the invention and its developments. The figure shows, schematically, a PEM fuel cell system.

25 According to the figure, a fuel cell system 40 comprises a PEM fuel cell (cell 2) which has an anode gas area 4 and a cathode gas area 6. The anode and cathode gas areas 4 and 6, respectively, are separated from one another by a membrane electrode unit 8.

20365-3981

- 5a -

Agents are supplied to and extracted from the anode gas area 4 via a supply pipe 10 having a first controllable valve 12, and via an outlet pipe 14 having a second controllable valve 16. Agents are supplied to and
5 extracted from the cathode gas area 6 in a corresponding manner via a supply pipe 18 having a third controllable valve 20, and via an outlet pipe 22 having a fourth controllable valve 24. The cell 2 can be purged with nitrogen (N₂) via a further supply pipe 42 having a fifth
10 controllable valve 44,

GR 96 P 3979 P

- 6 -

the supply pipe 42 bifurcating and opening into the supply pipes 10, 18.

The controllable valves 12, 16, 20, 24 and 44 are connected to a controller 46.

5 The electric current produced in the cell 2 is fed via an electrical cable 28 to a load 48 for further use. The electrical cable 28 contains an electric switch 50, via which the electric current flows out of the cell 2 when the switch 50 is closed. When the switch 50 is
10 open, the electrical cell voltage U of the cell 2 can be measured via an electrical cable 26 having a voltmeter 52 connected in it, without any electric current flowing.

 In the case of a method for identifying a gas
15 leak 32 between the anode and cathode gas areas 4 and 6, respectively, in the membrane electrode unit 8, the anode and cathode gas areas 4 and 6, respectively, are purged with nitrogen (N_2) in first time period. This measure results in an inert state being achieved in the
20 anode and cathode gas areas 4 and 6, respectively. Another inert gas can also be used to achieve this inert state. The controllable valves 44, 16 and 24 are open in the first time period.

 The nitrogen (N_2) is then removed from the cell
25 2, for example by pumping it out, via the outlet pipes 14 and 22.

 In a second time period, which follows the first time period in time, the cathode gas area 6 is filled

GR 96 P 3979 P

- 7 -

for about 1 s with oxygen (O_2) at an absolute pressure of about 2.3 bar.

After this, the valve 20 in the supply pipe 18 for the cathode gas area 6 is closed, in order to prevent any further oxygen (O_2) from being supplied. The oxygen (O_2) is now virtually completely removed via the outlet pipe 22, and the valve 24 in the outlet pipe 22 is then closed. A residual amount of oxygen (O_2) remains on the cathode 30 of the membrane electrode unit 8 as a result of adsorption, which residual amount has not been removed from cathode gas area 6.

The anode gas area 4 is filled with hydrogen (H_2) for about 0.1 s at an absolute pressure of about 2.0 bar in a second time period, with the valve 16 closed. After filling, the valve 12 in the supply pipe 10 is closed. This measure results in the amount of hydrogen (H_2) which can react being limited to the volume of the anode gas area 4 and the associated sections of the supply pipe 10 and of the outlet pipe 14.

After completion of this procedure, the valves 12, 16, 20, 24 and 44 are closed, and the cell 2 is isolated from its environment in a gas-tight manner. When the fuel cell system 40 is in this state, the cell voltage U of the cell 2 is measured with the switch 50 open, that is to say with no electric current flowing. The measurement should in each case be started immediately after the second time period.

The cell voltage U , that is to say the no-load voltage, has a value of about 1 V at the start of the measurement. If the cell 2 has no gas leak in the membrane electrode unit 8, then the cell voltage U falls to 0 V within a time period of about 1 min. In contrast, if the cell 2 has a gas leak, then

the voltage falls considerably faster, since the hydrogen (H_2) in the anode gas area 4 reacts directly with the oxygen (O_2) in the cathode gas area 6. The criterion for the presence of a gas leak is thus defined as the cell voltage U falling below a limit value U_G , which is considerably less than the no-load voltage, within a predetermined time interval which is considerably less than 1 min.

This time period should be between 15 and 20 s. A time period of 16 s, in particular, has been proven in practice, the limit value U_G being about half the no-load voltage, that is to say about 0.5 V. Thus, if the cell voltage U falls below this limit value U_G within this time period, then there is a gas leak 32 in the cell 2.

Owing to the fact that the cell voltage U which can be evaluated is in the region of the no-load voltage, the method has adequately high sensitivity. In a fuel cell block which comprises a number of cells, the method can also be applied to a number of cells (up to 5, for example) connected in series. In fact, in this case, all that can be decided is whether there is a defective cell in this group of cells. The limit value U_G must then be adapted, corresponding to the number of cells in the group to be examined.

20365-3981

- 9 -

CLAIMS:

1. A method for identifying a gas leak (32) between the anode and cathode gas areas (4 and 6, respectively) of a PEM fuel cell (2) by detecting the cell voltage U,
5 characterized in that the anode and cathode gas areas (4 and 6, respectively) are purged with nitrogen (N₂) in a first time period, the cathode gas area (6) is filled with oxygen (O₂) and the anode gas area (4) with hydrogen (H₂) in a second time period, and the drop in the cell
10 voltage U below a limit value U_G as a function of time is then measured and evaluated.
2. The method as claimed in claim 1, characterized in that the anode gas area (4) and/or the cathode gas area (6) are/is kept closed during the measurement.
- 15 3. The method as claimed in any one of claims 1 and 2, characterized in that the nitrogen (N₂) is removed from the anode and cathode gas areas (4 and 6, respectively) between the first and second time periods.
4. The method as claimed in any one of claims 1 to 3,
20 characterized in that the cathode gas area (6) is filled with oxygen (O₂) for about 1 s, at an absolute pressure of about 2.3 bar, during the second time period.
5. The method as claimed in any one of claims 1 to 4,
25 characterized in that the majority of the oxygen (O₂) is removed after the second time period.
6. The method as claimed in any one of claims 1 to 5, characterized in that the limit value U_G is half the no-load voltage of the PEM fuel cell (2).

20365-3981

- 10 -

7. The method as claimed in any one of claims 1 to 6, characterized in that the cell voltage U is measured for 15 to 20 s.

8. The method as claimed in any one of claims 1 to 7, characterized in that the anode gas area (4) is filled with hydrogen (H_2) for about 0.1 s, at an absolute pressure of about 2.0 bar, during the second time period.

9. A fuel cell system (40) having a PEM fuel cell (2), which has connections (42, 26, 28) for supplying nitrogen (N_2) and for tapping off an electrical voltage, and having a controller (46) for carrying out the method as claimed in any one of claims 1 to 8.

10. The method as claimed in any one of claims 1 to 5, characterized in that the limit value U_G is 0.5 V.

11. The method as claimed in any one of claims 1 to 6, characterized in that the cell voltage U is measured for 16 s.

FETHERSTONHAUGH & CO.

OTTAWA, CANADA

PATENT AGENTS

