



US011382797B2

(12) **United States Patent**
Robinson et al.

(10) **Patent No.:** **US 11,382,797 B2**
(45) **Date of Patent:** ***Jul. 12, 2022**

(54) **BREATHABLE INTERFACE SYSTEM FOR TOPICAL REDUCED PRESSURE**

(71) Applicant: **KCI Licensing, Inc.**, San Antonio, TX (US)

(72) Inventors: **Timothy Mark Robinson**, Shillingstone (GB); **Christopher Brian Locke**, Bournemouth (GB)

(73) Assignee: **KCI Licensing, Inc.**, San Antonio, TX (US)

(*) Notice: Subject to any disclaimer, the term of this patent is extended or adjusted under 35 U.S.C. 154(b) by 570 days.
This patent is subject to a terminal disclaimer.

(21) Appl. No.: **16/412,519**

(22) Filed: **May 15, 2019**

(65) **Prior Publication Data**
US 2019/0262183 A1 Aug. 29, 2019

Related U.S. Application Data

(63) Continuation of application No. 15/369,242, filed on Dec. 5, 2016, now Pat. No. 10,335,321, which is a (Continued)

(51) **Int. Cl.**
A61F 13/00 (2006.01)
A61M 1/00 (2006.01)
A61F 13/02 (2006.01)

(52) **U.S. Cl.**
CPC .. **A61F 13/00068** (2013.01); **A61F 13/00017** (2013.01); **A61F 13/00029** (2013.01); (Continued)

(58) **Field of Classification Search**
CPC A61F 13/00068; A61F 13/00017; A61F 13/00029; A61F 13/00046; A61F 13/0203; A61F 13/0216; A61M 1/0088
See application file for complete search history.

(56) **References Cited**
U.S. PATENT DOCUMENTS
1,355,846 A 10/1920 Rannells
2,547,758 A 4/1951 Keeling
(Continued)

FOREIGN PATENT DOCUMENTS
AU 550575 B2 3/1986
AU 745271 B2 3/2002
(Continued)

OTHER PUBLICATIONS
Louis C. Argenta, MD and Michael J. Morykwas, PHD; Vacuum-Assisted Closure: A New Method for Wound Control and Treatment: Clinical Experience; Annals of Plastic Surgery; vol. 38, No. 6, Jun. 1997; pp. 563-576.
(Continued)

Primary Examiner — Ophelia A Hawthorne

(57) **ABSTRACT**
A reduced pressure tissue treatment system includes an applicator having an aperture, a first pad section, and a second pad section substantially covering the aperture and positioned substantially adjacent the first pad section. A fabric layer is located at least partially between the second pad section and the drape, and the fabric layer includes a woven or non-woven fabric made from a fiber material. A drape substantially covers the first pad section, the second pad section, the fabric layer, and the applicator. A reduced pressure source is in fluid communication with at least one of the first pad section and the fabric layer for providing reduced pressure to the aperture.

19 Claims, 4 Drawing Sheets

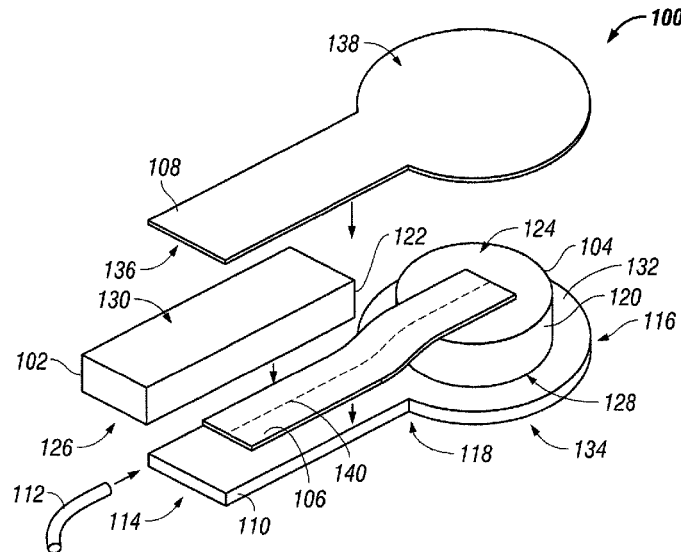

Related U.S. Application Data

continuation of application No. 14/925,784, filed on Oct. 28, 2015, now Pat. No. 9,526,660, which is a continuation of application No. 14/191,150, filed on Feb. 26, 2014, now Pat. No. 9,198,802, which is a continuation of application No. 13/430,088, filed on Mar. 26, 2012, now Pat. No. 8,680,359, which is a continuation of application No. 13/015,209, filed on Jan. 27, 2011, now Pat. No. 8,148,595, which is a continuation of application No. 12/069,245, filed on Feb. 8, 2008, now Pat. No. 7,880,050.

(60) Provisional application No. 60/900,463, filed on Feb. 9, 2007.

(52) **U.S. Cl.**
 CPC *A61F 13/00046* (2013.01); *A61F 13/0203* (2013.01); *A61F 13/0216* (2013.01); *A61M 1/75* (2021.05); *A61M 1/90* (2021.05)

(56) **References Cited**

U.S. PATENT DOCUMENTS

2,632,443 A 3/1953 Leshner
 2,682,873 A 7/1954 Evans et al.
 2,910,763 A 11/1959 Lauterbach
 2,969,057 A 1/1961 Simmons
 3,066,672 A 12/1962 Crosby, Jr. et al.
 3,367,332 A 2/1968 Groves
 3,520,300 A 7/1970 Flower, Jr.
 3,568,675 A 3/1971 Harvey
 3,648,692 A 3/1972 Wheeler
 3,682,180 A 8/1972 McFarlane
 3,826,254 A 7/1974 Mellor
 4,080,970 A 3/1978 Miller
 4,096,853 A 6/1978 Weigand
 4,139,004 A 2/1979 Gonzalez, Jr.
 4,165,748 A 8/1979 Johnson
 4,184,510 A 1/1980 Murry et al.
 4,233,969 A 11/1980 Lock et al.
 4,245,630 A 1/1981 Lloyd et al.
 4,256,109 A 3/1981 Nichols
 4,261,363 A 4/1981 Russo
 4,275,721 A 6/1981 Olson
 4,284,079 A 8/1981 Adair
 4,297,995 A 11/1981 Golub
 4,333,468 A 6/1982 Geist
 4,373,519 A 2/1983 Errede et al.
 4,382,441 A 5/1983 Svedman
 4,392,853 A 7/1983 Muto
 4,392,858 A 7/1983 George et al.
 4,419,097 A 12/1983 Rowland
 4,465,485 A 8/1984 Kashmer et al.
 4,475,909 A 10/1984 Eisenberg
 4,480,638 A 11/1984 Schmid
 4,525,166 A 6/1985 Leclerc
 4,525,374 A 6/1985 Vaillancourt
 4,540,412 A 9/1985 Van Overloop
 4,543,100 A 9/1985 Brodsky
 4,548,202 A 10/1985 Duncan
 4,551,139 A 11/1985 Plaas et al.
 4,569,348 A 2/1986 Hasslinger
 4,605,399 A 8/1986 Weston et al.
 4,608,041 A 8/1986 Nielsen
 4,640,688 A 2/1987 Hauser
 4,655,754 A 4/1987 Richmond et al.
 4,664,662 A 5/1987 Webster
 4,710,165 A 12/1987 McNeil et al.
 4,733,659 A 3/1988 Edenbaum et al.
 4,743,232 A 5/1988 Kruger
 4,758,220 A 7/1988 Sundblom et al.
 4,787,888 A 11/1988 Fox
 4,826,494 A 5/1989 Richmond et al.
 4,838,883 A 6/1989 Matsuura

4,840,187 A 6/1989 Brazier
 4,863,449 A 9/1989 Therriault et al.
 4,872,450 A 10/1989 Austad
 4,878,901 A 11/1989 Sachse
 4,897,081 A 1/1990 Poirier et al.
 4,906,233 A 3/1990 Moriuchi et al.
 4,906,240 A 3/1990 Reed et al.
 4,919,654 A 4/1990 Kalt
 4,941,882 A 7/1990 Ward et al.
 4,953,565 A 9/1990 Tachibana et al.
 4,969,880 A 11/1990 Zamierowski
 4,985,019 A 1/1991 Michelson
 5,037,397 A 8/1991 Kalt et al.
 5,086,170 A 2/1992 Luheshi et al.
 5,092,858 A 3/1992 Benson et al.
 5,100,396 A 3/1992 Zamierowski
 5,134,994 A 8/1992 Say
 5,149,331 A 9/1992 Ferdman et al.
 5,167,613 A 12/1992 Karami et al.
 5,176,663 A 1/1993 Svedman et al.
 5,215,522 A 6/1993 Page et al.
 5,232,453 A 8/1993 Plass et al.
 5,261,893 A 11/1993 Zamierowski
 5,278,100 A 1/1994 Doan et al.
 5,279,550 A 1/1994 Habib et al.
 5,298,015 A 3/1994 Komatsuzaki et al.
 5,342,376 A 8/1994 Ruff
 5,344,415 A 9/1994 DeBusk et al.
 5,358,494 A 10/1994 Svedman
 5,437,622 A 8/1995 Carion
 5,437,651 A 8/1995 Todd et al.
 5,527,293 A 6/1996 Zamierowski
 5,549,584 A 8/1996 Gross
 5,556,375 A 9/1996 Ewall
 5,607,388 A 3/1997 Ewall
 5,636,643 A 6/1997 Argenta et al.
 5,645,081 A 7/1997 Argenta et al.
 6,071,267 A 6/2000 Zamierowski
 6,135,116 A 10/2000 Vogel et al.
 6,241,747 B1 6/2001 Ruff
 6,287,316 B1 9/2001 Agarwal et al.
 6,345,623 B1 2/2002 Heaton et al.
 6,488,643 B1 12/2002 Tumey et al.
 6,493,568 B1 12/2002 Bell et al.
 6,553,998 B2 4/2003 Heaton et al.
 6,814,079 B2 11/2004 Heaton et al.
 7,846,141 B2 12/2010 Weston
 8,062,273 B2 11/2011 Weston
 8,216,198 B2 7/2012 Heagle et al.
 8,251,979 B2 8/2012 Malhi
 8,257,327 B2 9/2012 Blott et al.
 8,398,614 B2 3/2013 Blott et al.
 8,449,509 B2 5/2013 Weston
 8,529,548 B2 9/2013 Blott et al.
 8,535,296 B2 9/2013 Blott et al.
 8,551,060 B2 10/2013 Schuessler et al.
 8,568,386 B2 10/2013 Malhi
 8,679,081 B2 3/2014 Heagle et al.
 8,834,451 B2 9/2014 Blott et al.
 8,926,592 B2 1/2015 Blott et al.
 9,017,302 B2 4/2015 Vitaris et al.
 9,198,801 B2 12/2015 Weston
 9,211,365 B2 12/2015 Weston
 9,289,542 B2 3/2016 Blott et al.
 9,526,660 B2* 12/2016 Robinson A61F 13/00046
 10,335,321 B2* 7/2019 Robinson A61M 1/90
 2002/0077661 A1 6/2002 Saadat
 2002/0115951 A1 8/2002 Norstrom et al.
 2002/0120185 A1 8/2002 Johnson
 2002/0143286 A1 10/2002 Tumey
 2014/0163491 A1 6/2014 Schuessler et al.
 2015/0080788 A1 3/2015 Blott et al.

FOREIGN PATENT DOCUMENTS

AU 755496 B2 12/2002
 CA 2005436 A1 6/1990
 DE 26 40 413 A1 3/1978
 DE 43 06 478 A1 9/1994

(56)

References Cited

FOREIGN PATENT DOCUMENTS

DE	29 504 378	U1	9/1995
EP	0100148	A1	2/1984
EP	0117632	A2	9/1984
EP	0161865	A2	11/1985
EP	0358302	A2	3/1990
EP	1018967	A1	7/2000
GB	692578	A	6/1953
GB	2 195 255	A	4/1988
GB	2 197 789	A	6/1988
GB	2 220 357	A	1/1990
GB	2 235 877	A	3/1991
GB	2 329 127	A	3/1999
GB	2 333 965	A	8/1999
JP	4129536	B2	8/2008
SG	71559		4/2002
WO	80/02182	A1	10/1980
WO	87/04626	A1	8/1987
WO	90/010424	A1	9/1990
WO	93/009727	A1	5/1993
WO	94/020041	A1	9/1994
WO	96/05873	A1	2/1996
WO	97/18007	A1	5/1997
WO	99/13793	A1	3/1999

OTHER PUBLICATIONS

Susan Mendez-Eatmen, RN; "When wounds Won't Heal" RN Jan. 1998, vol. 61 (1); Medical Economics Company, Inc., Montvale, NJ, USA; pp. 20-24.

James H. Blackburn II, MD et al.: Negative-Pressure Dressings as a Bolster for Skin Grafts; *Annals of Plastic Surgery*, vol. 40, No. 5, May 1998, pp. 453-457; Lippincott Williams & Wilkins, Inc., Philadelphia, PA, USA.

John Masters; "Reliable, Inexpensive and Simple Suction Dressings"; Letter to the Editor, *British Journal of Plastic Surgery*, 1998, vol. 51 (3), p. 267; Elsevier Science/The British Association of Plastic Surgeons, UK.

S.E. Greer, et al. "The Use of Subatmospheric Pressure Dressing Therapy to Close Lymphocutaneous Fistulas of the Groin" *British Journal of Plastic Surgery* (2000), 53, pp. 484-487.

George V. Letsou, MD., et al.; "Stimulation of Adenylate Cyclase Activity in Cultured Endothelial Cells Subjected to Cyclic Stretch"; *Journal of Cardiovascular Surgery*, 31, 1990, pp. 634-639.

Orringer, Jay, et al.; "Management of Wounds in Patients with Complex Enterocutaneous Fistulas"; *Surgery, Gynecology & Obstetrics*, Jul. 1987, vol. 165, pp. 79-80.

International Search Report for PCT International Application PCT/GB95/01983; dated Nov. 23, 1995.

PCT International Search Report for PCT International Application PCT/GB98/02713; dated Jan. 8, 1999.

PCT Written Opinion; PCT International Application PCT/GB98/02713; dated Jun. 8, 1999.

PCT International Examination and Search Report, PCT International Application PCT/GB96/02802; dated Jan. 15, 1998 & Apr. 29, 1997.

PCT Written Opinion, PCT International Application PCT/GB96/02802; dated Sep. 3, 1997.

Dattilo, Philip P., Jr., et al.; "Medical Textiles: Application of an Absorbable Barbed Bi-directional Surgical Suture"; *Journal of Textile and Apparel, Technology and Management*, vol. 2, Issue 2, Spring 2002, pp. 1-5.

Kostyuchenok, B.M., et al.; "Vacuum Treatment in the Surgical Management of Purulent Wounds"; *Vestnik Khirurgi*, Sep. 1986, pp. 18-21 and 6 page English translation thereof.

Davydov, Yu. A., et al.; "Vacuum Therapy in the Treatment of Purulent Lactation Mastitis"; *Vestnik Khirurgi*, May 14, 1986, pp. 66-70, and 9 page English translation thereof.

Yusupov, Yu.N., et al.; "Active Wound Drainage"; *Vestnik Khirurgi*, vol. 138, Issue 4, 1987, and 7 page English translation thereof.

Davydov, Yu.A., et al.; "Bacteriological and Cytological Assessment of Vacuum Therapy for Purulent Wounds"; *Vestnik Khirurgi*, Oct. 1988, pp. 48-52, and 8 page English translation thereof.

Davydov, Yu.A., et al.; "Concepts for the Clinical-Biological Management of the Wound Process in the Treatment of Purulent Wounds by Means of Vacuum Therapy"; *Vestnik Khirurgi*, Jul. 7, 1980, pp. 132-136, and 8 page English translation thereof.

Chariker, Mark E., M.D., et al.; "Effective Management of incisional and cutaneous fistulae with closed suction Around drainage"; *Contemporary Surgery*, vol. 34, Jun. 1989, pp. 59-63.

Egnell Minor, Instruction Book, First Edition, 300 7502, Feb. 1975, pp. 24.

Egnell Minor: Addition to the Users Manual Concerning Overflow Protection—Concerns all Egnell Pumps, Feb. 3, 1983, pp. 2.

Svedman, P.: "Irrigation Treatment of Leg Ulcers", *The Lancet*, Sep. 3, 1983, pp. 532-534.

Chinn, Steven D. et al.: "Closed Wound Suction Drainage", *The Journal of Foot Surgery*, vol. 24, No. 1, 1985, pp. 76-81.

Arnljots, Bjorn et al.: "Irrigation Treatment in Split-Thickness Skin Grafting of Intractable Leg Ulcers", *Scand J. Plast Reconstr. Surg.*, No. 19, 1985, pp. 211-213.

Svedman, P.: "A Dressing Allowing Continuous Treatment of a Biosurface", *IRCS Medical Science: Biomedical Technology, Clinical Medicine, Surgery and Transplantation*, vol. 7, 1979, p. 221.

Svedman, P. et al.: "A Dressing System Providing Fluid Supply and Suction Drainage Used for Continuous of ntermittent Irrigation", *Annals of Plastic Surgery*, vol. 17, No. 2, Aug. 1986, pp. 125-133.

N.A. Bagautdinov, "Variant of External Vacuum Aspiration in the Treatment of Purulent Diseases of Soft Tissues," *Current Problems in Modern Clinical Surgery: Interdepartmental Collection*, edited by V. Ye Volkov et al. (Chuvashia State University, Cheboksary, U.S.S.R. 1986); pp. 94-96 (certified translation).

K.F. Jeter, T.E. Tintle, and M. Chariker, "Managing Draining Wounds and Fistulae: New and Established Methods," *Chronic Wound Care*, edited by D. Krasner (Health Management Publications, Inc., King of Prussia, PA 1990), pp. 240-246.

G. Živadino?, V. ?uki?, Ž. Maksimovi?, ?. Radak, and P. Peška, "Vacuum Therapy in the Treatment of Peripheral Blood Vessels," *Timok Medical Journal* 11 (1986), pp. 161-164 (certified translation).

F.E. Johnson, "An Improved Technique for Skin Graft Placement Using a Suction Drain," *Surgery, Gynecology, and Obstetrics* 159 (1984), pp. 584-585.

A.A. Safronov, Dissertation Abstract, Vacuum Therapy of Trophic Ulcers of the Lower Leg with Simultaneous Autoplasty of the Skin (Central Scientific Research Institute of Traumatology and Orthopedics, Moscow, U.S.S.R. 1967) (certified translation).

M. Schein, R. Saadia, J.R. Jamieson, and G.A.G. Decker, "The 'Sandwich Technique' in the Management of the Open Abdomen," *British Journal of Surgery* 73 (1986), pp. 369-370.

D.E. Tribble, An Improved Sump Drain-Irrigation Device of Simple Construction, *Archives of Surgery* 105 (1972) pp. 511-513.

M.J. Morykwas, L.C. Argenta, E.I. Shelton-Brown, and W. McGuirt, "Vacuum-Assisted Closure: A New Method for Wound Control and Treatment: Animal Studies and Basic Foundation," *Annals of Plastic Surgery* 38 (1997), pp. 553-562 (Morykwas I).

C.E. Tennants, "The Use of Hyperemia in the Postoperative Treatment of Lesions of the Extremities and Thorax," *Journal of the American Medical Association* 64 (1915), pp. 1548-1549.

Selections from W. Meyer and V. Schmieden, Bier's Hyperemic Treatment in Surgery, Medicine, and the Specialties: A Manual of Its Practical Application, (W.B. Saunders Co., Philadelphia, PA 1909), pp. 17-25, 44-64, 90-96, 167-170, and 210-211.

V.A. Solovev et al., Guidelines, The Method of Treatment of Immature External Fistulas in the Upper Gastrointestinal Tract, editor-in-chief Prov. V.I. Parahonyak (S.M. Kirov Gorky State Medical Institute, Gorky, U.S.S.R. 1987) ("Solovev Guidelines").

V.A. Kuznetsov & N.a. Bagautdinov, "Vacuum and Vacuum-Sorption Treatment of Open Septic Wounds," in II All-Union Conference on Wounds and Wound Infections: Presentation Abstracts, edited by B.M. Kostyuchenok et al. (Moscow, U.S.S.R. Oct. 28-29, 1986) pp. 91-92 ("Bagautdinov II").

(56)

References Cited

OTHER PUBLICATIONS

V.A. Solovev, Dissertation Abstract, Treatment and Prevention of Suture Failures after Gastric Resection (S.M. Kirov Gorky State Medical Institute, Gorky, U.S.S.R. 1988) ("Solovev Abstract").
V.A.C. ® Therapy Clinical Guidelines: A Reference Source for Clinicians; Jul. 2007.

* cited by examiner

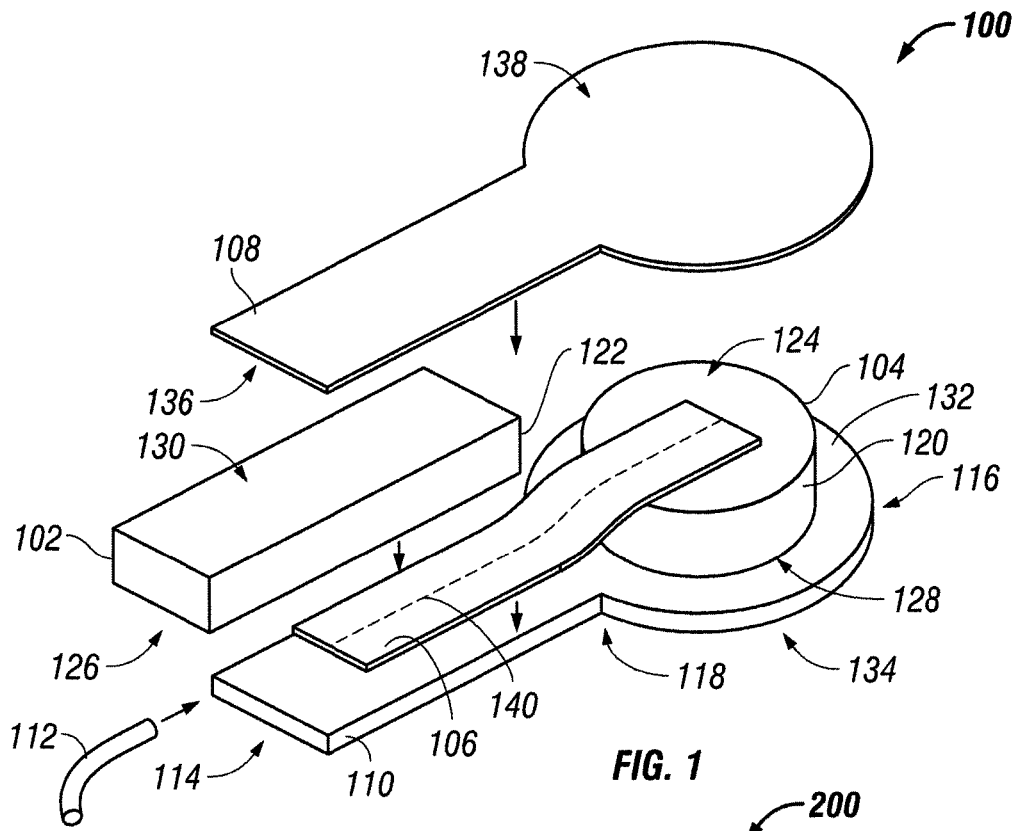

FIG. 1

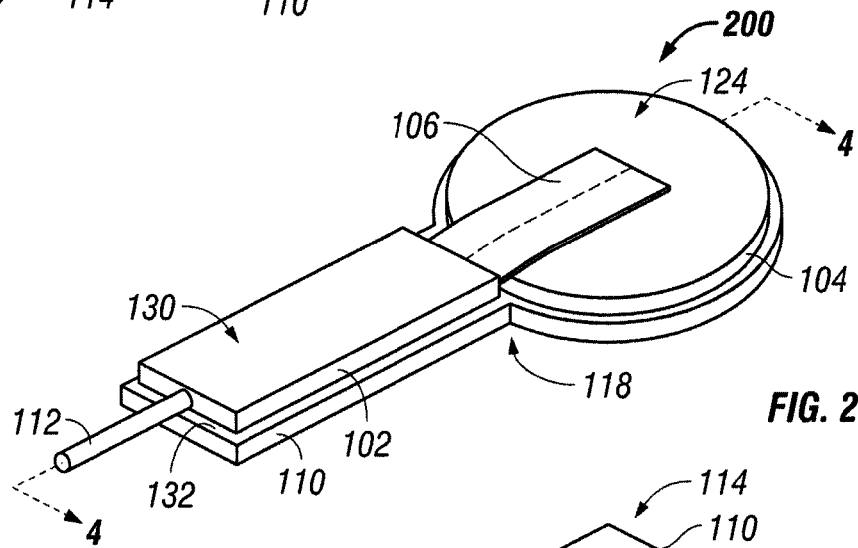

FIG. 2

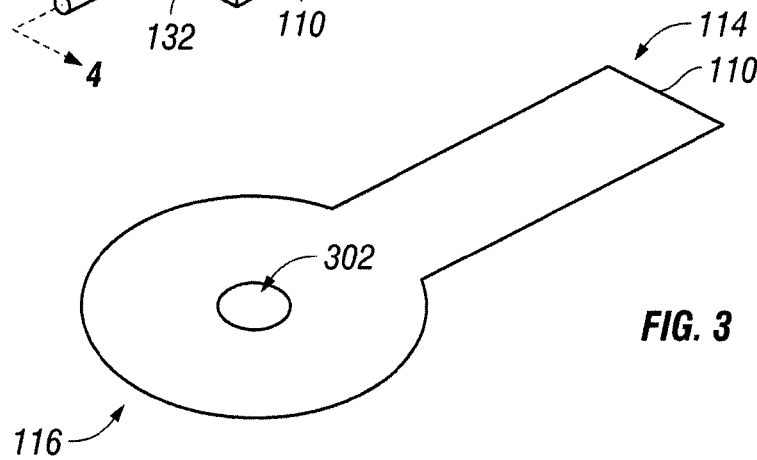

FIG. 3

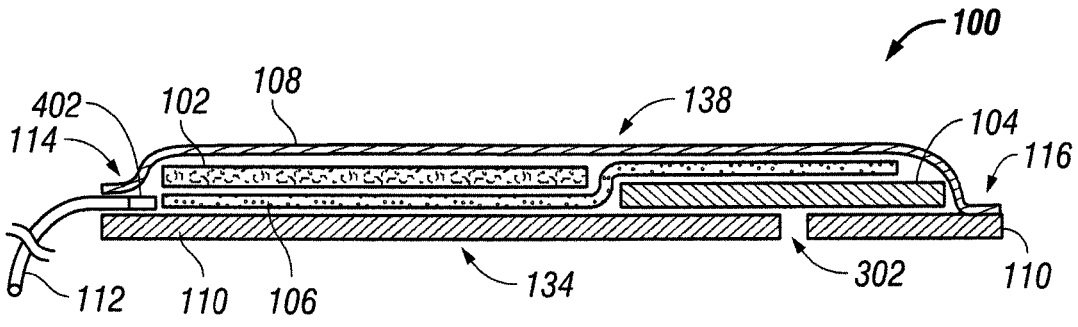

FIG. 4

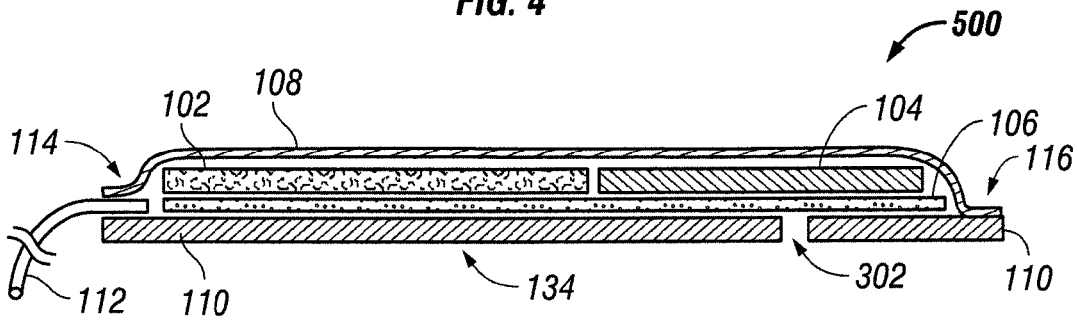

FIG. 5

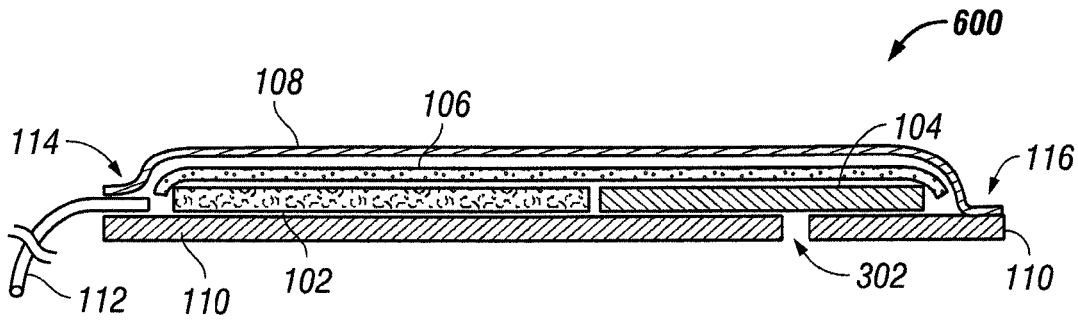

FIG. 6

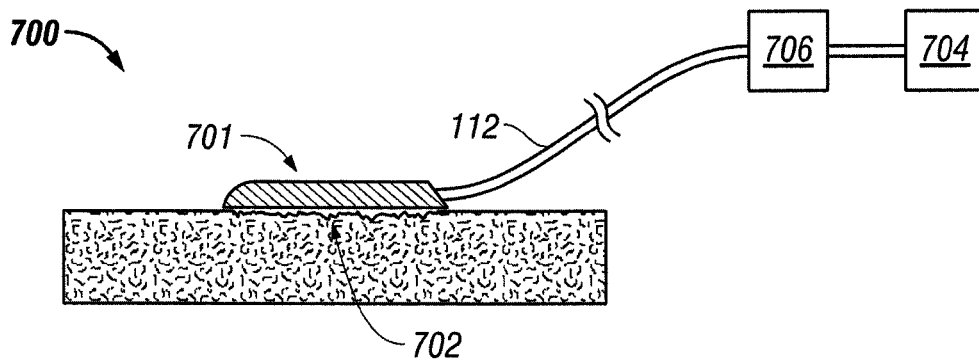

FIG. 7

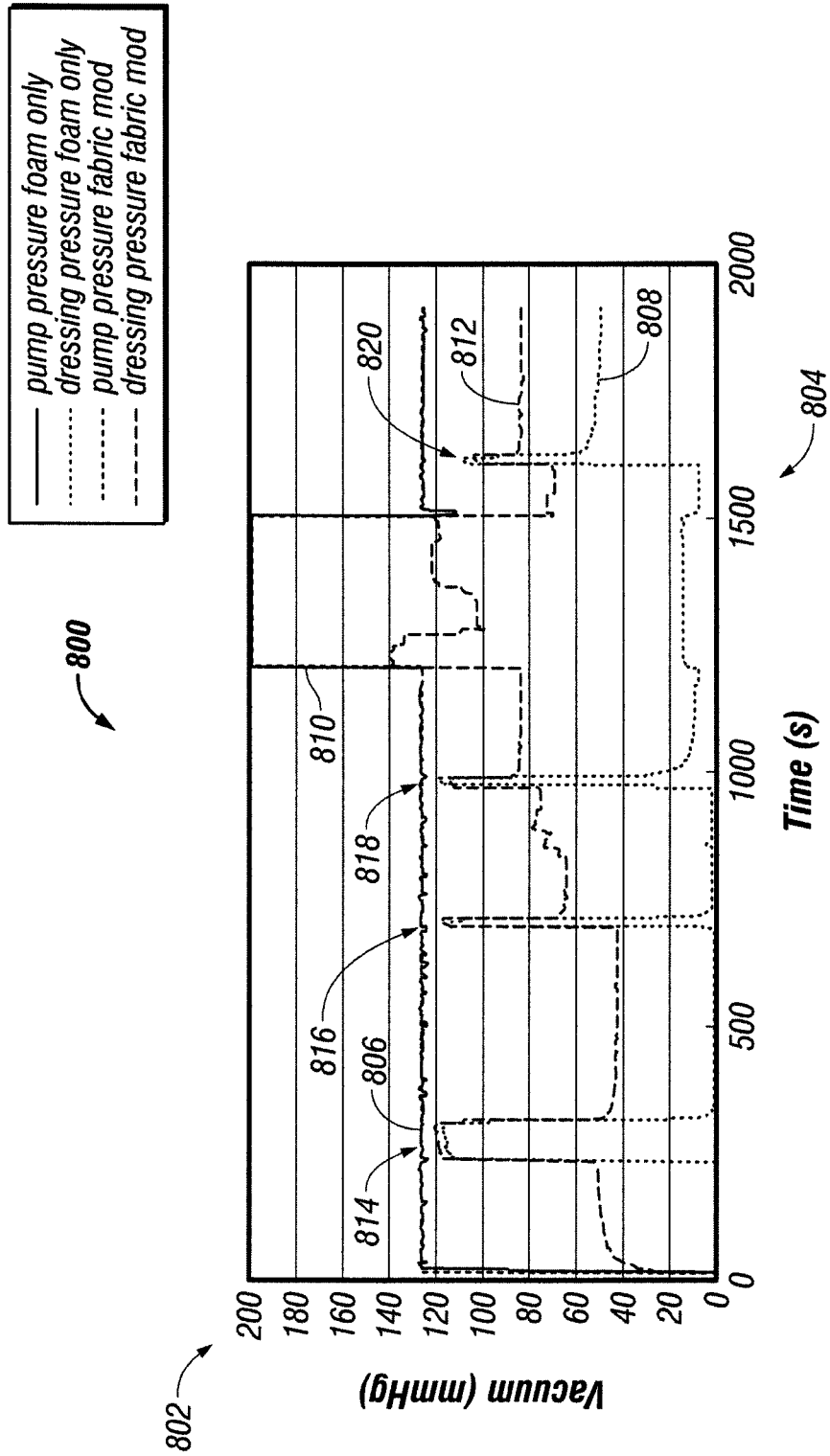

FIG. 8

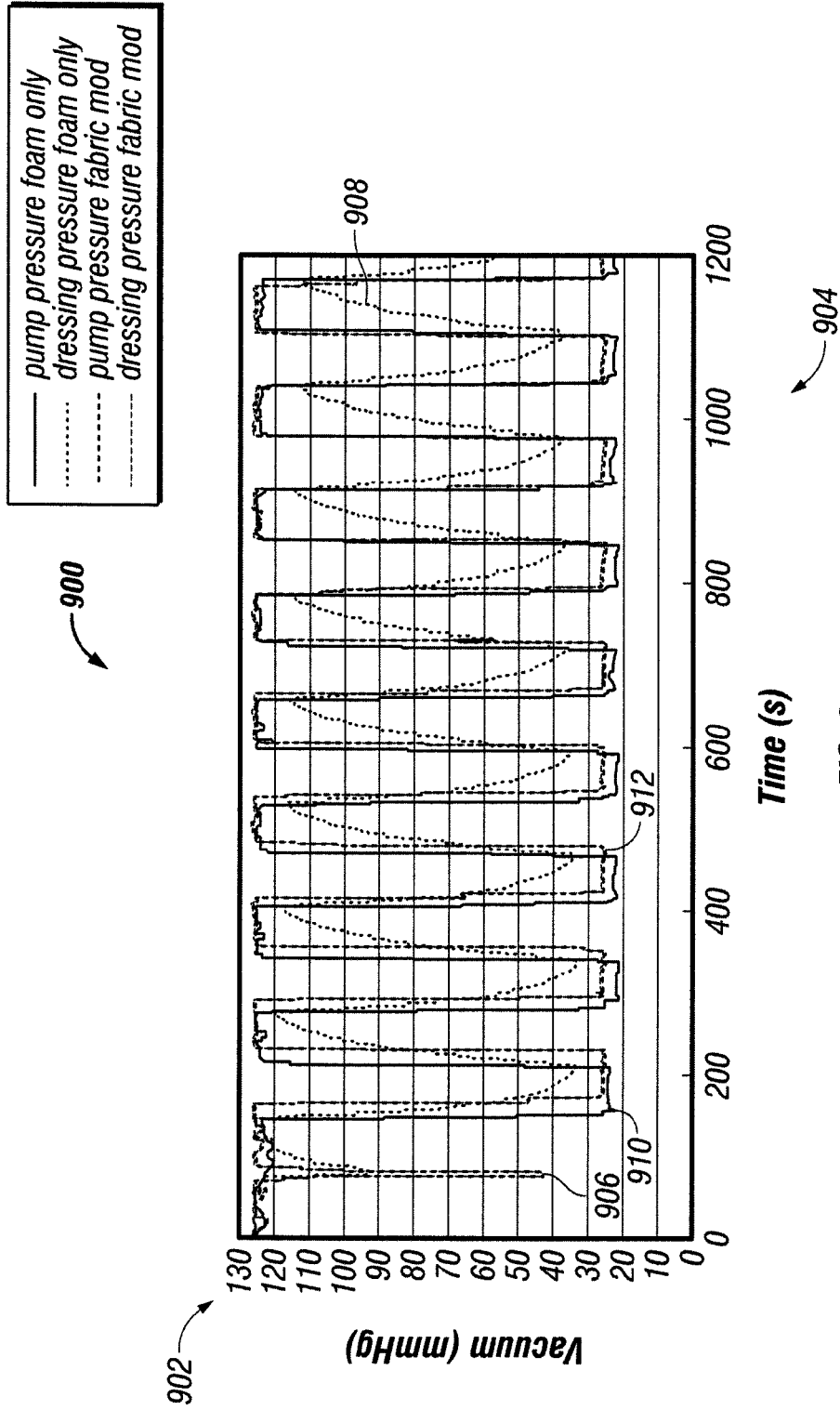

FIG. 9

BREATHABLE INTERFACE SYSTEM FOR TOPICAL REDUCED PRESSURE

CROSS-REFERENCE TO RELATED APPLICATIONS

This application is a continuation of U.S. patent application Ser. No. 15/369,242, filed Dec. 5, 2016, which is a continuation of U.S. patent application Ser. No. 14/925,784, filed Oct. 28, 2015, now U.S. Pat. No. 9,526,660, which is a continuation of U.S. patent application Ser. No. 14/191,150, filed Feb. 26, 2014, now U.S. Pat. No. 9,198,802, which is a continuation of U.S. patent application Ser. No. 13/430,088, filed Mar. 26, 2012, now U.S. Pat. No. 8,680,359, which is a continuation of U.S. application Ser. No. 13/015,209, filed Jan. 27, 2011, now U.S. Pat. No. 8,148,595, which is a continuation of U.S. patent application Ser. No. 12/069,245, filed Feb. 8, 2008, now U.S. Pat. No. 7,880,050, which claims the benefit of U.S. Provisional Application No. 60/900,463, filed Feb. 9, 2007, the disclosures which are hereby incorporated by reference.

BACKGROUND OF THE INVENTION

1. Field of the Invention

The present application relates generally to systems and methods for providing reduced pressure tissue treatment to open wounds and other tissue sites. More particularly, the present application relates to a breathable interface systems for topical reduced pressure.

2. Description of Related Art

Clinical studies and practice have shown that providing a reduced pressure in proximity to a tissue site augments and accelerates the growth of new tissue at the tissue site. The applications of this phenomenon are numerous, but application of reduced pressure has been particularly successful in treating wounds and tissue sites. This treatment (frequently referred to in the medical community as “negative pressure wound therapy,” “reduced pressure therapy,” or “vacuum therapy”) provides a number of benefits, including faster healing, and increased formulation of granulation tissue.

Reduced pressure tissue treatment has recently been popularized by Kinetic Concepts, Inc. of San Antonio, Tex., through its commercially available VAC reduced pressure tissue treatment systems product line. In general, such reduced pressure tissue treatment systems comprise a pad-based dressing, which is applied to the tissue and is sometimes referred to as the “tissue interface” or the “wound interface.”

Current dressings, however, have several disadvantages. They are difficult to apply to small wounds, and often lead to maceration of the wound periphery. Traditionally, dressings have been rather cumbersome, limiting many patient activities. Simply sitting on or rolling onto a dressing may cause significant patient discomfort. Moreover, these actions may compress the dressing and interfere with the application of reduced pressure to a manifold at the tissue site.

BACKGROUND OF THE INVENTION

Summary

The problems presented with these conventional dressings are solved by an improved breathable interface system

for topical reduced pressure. In one illustrative embodiment, a reduced pressure tissue treatment system is provided and includes an applicator having an aperture, a first pad section, and a second pad section. The second pad section substantially covers the aperture and is positioned substantially adjacent the first pad section. A fabric layer is located at least partially between the second pad section and the drape, and the fabric layer includes a woven or non-woven fabric made from a fiber material. A drape substantially covers the first pad section, the second pad section, the fabric layer, and the applicator. A reduced pressure source is in fluid communication with at least one of the first pad section and the fabric layer for providing reduced pressure to the aperture.

In another illustrative embodiment, a reduced pressure tissue treatment system includes an applicator having an aperture, a first pad section, and a second pad section substantially covering the aperture and positioned substantially adjacent to the first pad section. A fabric layer is located at least partially between the first pad section and the applicator, and the fabric layer further is located at least partially between the second pad section and the applicator. A drape substantially covers the first pad section, the second pad section, the fabric layer, and the applicator. A reduced pressure source is in fluid communication with at least one of the first pad section and the fabric layer for providing reduced pressure to the aperture.

In yet another illustrative embodiment, a reduced pressure tissue treatment system includes an applicator having an aperture, a first pad section, and a second pad section substantially covering the aperture and positioned substantially adjacent to the first pad section. A fabric layer is located at least partially between the first pad section and the drape, and the fabric layer further is located at least partially between the second pad section and the drape. A drape substantially covers the first pad section, the second pad section, the fabric layer, and the applicator. A reduced pressure source is in fluid communication with at least one of the first pad section and the fabric layer for providing reduced pressure to the aperture.

Other objects, features, and advantages of the illustrative embodiments will become apparent with reference to the drawings and the detailed description that follow.

BRIEF DESCRIPTION OF THE DRAWINGS

FIG. 1 is an exploded view of the breathable interface system according to an illustrative embodiment of the invention;

FIG. 2 is a perspective view of the breathable interface system without a drape according to an illustrative embodiment of the invention;

FIG. 3 is a bottom view of an applicator of a breathable interface system of FIGS. 1 and 2 according to an illustrative embodiment of the invention;

FIG. 4 is cross-sectional view of the breathable interface system along lines 4-4 of FIG. 2 according to an illustrative embodiment of the invention;

FIG. 5 is cross-sectional view of the breathable interface system according to another illustrative embodiment of the invention;

FIG. 6 is cross-sectional view of the breathable interface system according to another illustrative embodiment of the invention;

FIG. 7 is a schematic diagram of a reduced pressure tissue treatment system having a breathable interface system according to an illustrative embodiment of the invention;

FIG. 8 is a chart that compares the results of pressure transmission experiments on a conventional dressing and a breathable interface system according to an illustrative embodiment of the present invention; and

FIG. 9 is a chart that compares response times when subjected to intermittent application of reduced pressure under dry conditions of a conventional dressing and a breathable interface system according to an illustrative embodiment of the present invention.

DETAILED DESCRIPTION OF A PREFERRED EMBODIMENT

In the following detailed description of the preferred embodiments, reference is made to the accompanying drawings that form a part hereof, and in which is shown by way of illustration specific preferred embodiments in which the invention may be practiced. These embodiments are described in sufficient detail to enable those skilled in the art to practice the invention, and it is understood that other embodiments may be utilized and that logical, structural, mechanical, electrical, and chemical changes may be made without departing from the spirit or scope of the invention. To avoid detail not necessary to enable those skilled in the art to practice the invention, the description may omit certain information known to those skilled in the art. The following detailed description is, therefore, not to be taken in a limiting sense, and the scope of the present invention is defined only by the appended claims.

The term “reduced pressure” as used herein generally refers to a pressure less than the ambient pressure at a tissue site that is being subjected to treatment. In most cases, this reduced pressure will be less than the atmospheric pressure at which the patient is located. Alternatively, the reduced pressure may be less than a hydrostatic pressure of tissue at the tissue site. Although the terms “vacuum” and “negative pressure” may be used to describe the pressure applied to the tissue site, the actual pressure applied to the tissue site may be significantly less than the pressure normally associated with a complete vacuum. Reduced pressure may initially generate fluid flow in the tube in the area of the tissue site. As the hydrostatic pressure around the tissue site approaches the desired reduced pressure, the flow may subside, and the reduced pressure is then maintained. Unless otherwise indicated, values of pressure stated herein are gauge pressures.

The term “tissue site” as used herein refers to a wound or defect located on or within any tissue, including but not limited to, bone tissue, adipose tissue, muscle tissue, neural tissue, dermal tissue, vascular tissue, connective tissue, cartilage, tendons, or ligaments. The term “tissue site” may further refer to areas of any tissue that are not necessarily wounded or defective, but are instead areas in which it is desired to add or promote the growth of additional tissue. For example, reduced pressure tissue treatment may be used in certain tissue areas to grow additional tissue that may be harvested and transplanted to another tissue location.

Referring to FIGS. 1-3, an illustrative embodiment of a breathable interface system 100 is shown. In this embodiment, the breathable interface system 100 includes a first pad section 102, a second pad section 104, and a fabric layer 106, all positioned between a drape 108 and an applicator 110. The breathable interface system 100 generally has one end 116 that is located substantially adjacent to or over a tissue site and another end 114 that is located distally away from end 116, in one example. Nearer to end 114, the fabric layer 106 may be positioned or located at least partially between the applicator 110 and the first pad section 102. Nearer to

end 116, the fabric layer 106 may be positioned or located at least partially between the second pad section 104 and the drape 108. The fabric layer 106 extends along a portion of a top surface 124 of the second pad section 104 between the second pad section 104 and the drape 108. Once the fabric layer 106 reaches a side 120 of the second pad section 104 it transitions near the area 118 between the side 120 of the second pad section 104 and the side 122 of the first pad section 102 to extend along a portion of the bottom surface 126 of the first pad section 102 between the first pad section 102 and the applicator 110.

FIG. 2 is an illustrative embodiment of a breathable interface system 200 without the drape 108 placed on top of the first pad section 102, second pad section 104, and fabric layer 106 for illustration purposes. The fabric layer 106 can be seen extending over the top surface 124 of the second pad section 104 and beneath the bottom surface 126 of the first pad section 102. FIG. 3 is an illustrative embodiment of the applicator 110 including an aperture 302 that extends through the applicator 110 substantially near the end 116 of the applicator 110. The aperture 302 preferably is located near a tissue site to enable fluid to flow from the tissue site to the first pad section 102, second pad section 104, fabric layer 106, and reduced pressure conduit 112 of the breathable interface systems herein described.

In an illustrative embodiment, any hydrogel or bonding agent may be applied to the aperture 302 and the applicator 110 for sealing or contact purposes with a tissue site. The second pad section 104 is generally positioned to substantially cover the aperture 302, between the drape 108 and the applicator 110 as shown in FIGS. 4 and 6. In FIG. 5, the aperture 302 may be substantially covered by the fabric layer 106 as described herein. The size of the aperture 302 may vary to accommodate larger wounds, but in one embodiment, a size of about 10 to about 20 mm is advantageous for small wounds.

Referring to FIG. 4, an illustrative embodiment of the breathable interface system 100 is shown. The aperture 302 is shown disposed through the applicator 110. In addition, the breathable interface system 100 may further include an interface 402 that facilitates fluid communication between the first pad section 102 and/or fabric layer 106 and the reduced pressure conduit 112. Referring to FIG. 5, another illustrative embodiment of the breathable interface system 500 is shown. The breathable interface system 500 may include a different arrangement of the first pad section 102, second pad section 104, and fabric layer 106 between the drape 108 and the applicator 110. In this illustrative embodiment, the fabric layer 106 is located between the bottom surface 126 of the first pad section 102 and the bottom surface 128 of the second pad section 104 and the top surface 132 of the applicator 110. The first pad section 102 and second pad section 104 are located or positioned on top of the fabric layer 106. In this illustrative embodiment, the fabric layer 106 substantially covers the aperture 302. Referring to FIG. 6, yet another illustrative embodiment of the breathable interface system 600 is shown. In this illustrative embodiment, the fabric layer 106 is located between the top surface 124 of the second pad section 104 and the top surface 130 of the first pad section 102 and the bottom surface 136 of the drape 108.

In any of the breathable interface systems 100, 200, 500, and 600, the reduced pressure conduit 112 may be located in direct contact with the first pad section 102 and/or the fabric layer 106. The reduced pressure conduit 112 may be placed in direct contact with the first pad section 102 or the fabric layer 106 by directly inserting it into either of the first pad

section 102 or the fabric layer 106 near the end 114 of the breathable interface system 100. In another illustrative embodiment, the breathable interface systems 100, 200, 500, and 600 may further include the interface 402 as shown in FIG. 4 for facilitating the fluid communication and flow between the first pad section 102 and/or fabric layer 106 and the reduced pressure conduit 112. In yet another illustrative embodiment, the reduced pressure conduit 112 may not be in direct contact with the first pad section 102 and/or fabric layer 106, but may otherwise be in fluid communication with the first pad section 102 and/or fabric layer 106.

In one illustrative embodiment, the side 120 of the second pad section 104 extends between the top surface 124 and a bottom surface 128 of the second pad section 104. The bottom surface 128 of the second pad section 104 may have a surface area that may cover substantially all or a portion of the top surface 132 of the end 116 of the applicator 110. Additionally, the side 122 of the first pad section 102 extends between the top surface 130 and the bottom surface 126 of the first pad section 102. The bottom surface 126 of the first pad section 102 may have a surface area that may cover substantially all or a portion of the end 114 of the top surface 132 of the applicator 110.

The applicator 110 may be any size desirable to adequately provide effective covering and functionality to a tissue site as described herein. In one aspect, the applicator 110 includes a bottom surface 134 that may preferably contact the tissue site. The end 116 of the applicator 110 may have a surface area of a different shape than the end 114 of the applicator 110. For example, the surface area of the end 116 as shown in FIG. 1 shows a surface area of a substantially circular shape. Nevertheless, the shape of the end 116 of the applicator 110 may any desirable shape, symmetric, asymmetric, or otherwise, to provide the covering of a tissue site and functionality as herein described. In one illustrative embodiment, the end 114 of the applicator 110 may have a surface area that approximates a rectangular shape; however, the end 114 of the applicator 110 may also be any desirable shape, symmetric, asymmetric, or otherwise, to provide the covering and functionality as herein described.

Preferably, the bottom surface 136 of the drape 108 covers and secures the first pad section 102, fabric layer 106, and second pad section 104 to the top surface 132 of the applicator 110. In one aspect, the applicator 110 and drape 108 are sealed together substantially around the perimeter or periphery of their respective shapes. Preferably, the applicator 110 and drape 108 isolate the tissue site from its surrounding environment and maintain a reduced pressure at the tissue site when reduced pressure is applied as described herein. The applicator 110 may be secured to drape 108 with any suitable bonding agent, such as an acrylic adhesive or hydrogel. In addition, the applicator 110 may be joined to the drape 108 by other commonly known means, such as bonding, adhesives, welding, fastening, and sintering, for example. Typically, a hydrogel or other tissue-friendly bonding agent may be applied to the tissue side or bottom surface 134 of the applicator 110, which is then placed into the tissue site or in contact with the perimeter of the tissue site to secure the dressing to the tissue site.

In an illustrative embodiment, the first pad section 102 and second pad section 104 may be a material known in the art to be suitable for reduced pressure tissue treatment, the size and shape of which may be varied to accommodate tissue sites of various size and shape as described herein. Preferably, the first pad section 102 and second pad section 104 include a plurality of flow channels or pathways to facilitate the distribution of reduced pressure or fluids to or

from the tissue site. In one illustrative embodiment, the first pad section 102 and second pad section 104 are porous foam that includes interconnected cells or pores that act as flow channels. In addition to the above, the first pad section 102 and second pad section 104 may be a material such as an open cell, reticulated foam that is formed from a range of polymers, including without limitation polyurethane, polyolefin, vinyl acetate, polyvinyl alcohol, and their copolymers. Additionally, the first and second pad section 102, 104 may be woven or non-woven materials, including 3-dimensional fabric structures. The pads may also be made from a sintered polymer, including materials such as sintered polyolefin, ethylene vinyl acetate, and fluoropolymer. The first pad section 102 and second pad section 104 may also be any other type of open-cell, reticulated foam, such as GranuFoam® and Whitefoam™ that are manufactured by Kinetic Concepts, Inc. of San Antonio, Tex. If open-cell foam is used, the porosity may vary, but is preferably about 400 to 600 microns. Alternatively, gauze or any other material suited to a particular biological application may be used to construct first pad section 102 and second pad section 104. In a certain illustrative embodiment, first pad section 102 and second pad section 104 may be constructed as a single, unitary pad. In another illustrative embodiment, first pad section 102 and second pad section 104 may be a multi-component or multi-layered pad section. Preferably, the thicknesses of the first pad section 102 and second pad section 104 is from about 1 mm to about 50 mm, and in one implementation from about 5 mm to about 20 mm, although any thicknesses may be used.

In an illustrative embodiment, the fabric layer 106 may be a woven or non-woven fabric material known in the art, the size and shape of which may be varied to accommodate tissue sites of various size and shape as described herein. It may be constructed from any fiber material that maintains its structural integrity when exposed to fluids, such as polyamide, polyolefin, nylon, polyester, a polyamide coated with polyurethane, any polymeric mesh, a non-woven (air layed) melt blown polymer, or flexible sintered polymer. The fabric layer 106 may also be a fabric covered with adhesive or hydrogel to facilitate bonding to the tissue site, where the fabric layer 106 extends beyond the applicator 110. The material may be woven together to form a layer of appropriate dimensions, or it may be any type of open cell mesh construction of appropriate dimensions. As illustrated in FIG. 1, the fabric layer 106 may also be folded and include stitching 140 to provide additional channels and structural support. A folded fabric layer may be stitched lengthwise down the middle, as depicted in FIG. 2, around the edges, or any combination thereof. As an alternative to stitching, a folded fabric layer may be secured with an acrylic adhesive or any other suitable bonding agent. The fabric layer 106 may also include several overlapping layers joined together by any known means. Preferably, the thicknesses of the fabric layer 106 is from about 1 mm to about 50 mm, and more preferably about 5 mm to about 20 mm, although any thicknesses may be used.

The drape 108 may be a flexible material having a sufficiently high moisture vapor transmission rate ("MTVR") to preclude tissue maceration, typically greater than 600 mg/m²/day. In one aspect, plastics and thermoplastics are an example of suitable materials for the drape 108. And like the drape 108, the applicator 110 generally is constructed from any flexible material having a sufficiently high MTVR to preclude maceration of the tissue site, such as plastics and thermoplastics.

The reduced pressure conduit **112** may represent any conduit tubing, line, or path through which a gas, liquid, gel, or other fluid may be carried, and may have more than one internal lumen. While the reduced pressure conduit **112** may be inflexible, it is preferred that it be flexible enough for ease of use and comfort for a patient. The reduced pressure conduit is configured for connection to a reduced pressure source to provide delivery of reduced pressure.

In an illustrative embodiment, the breathable interface systems **100**, **200**, **500**, and **600** may be lightweight, low-profile interface systems for low-severity, small tissue sites, but the principles are readily extendable by a person of ordinary skill in the art to larger, more extensive tissue sites, as well as numerous other types of tissue treatments.

Referring again to FIGS. 1-6, the aperture **302** is placed over a tissue site and the reduced pressure source **704** delivers a reduced pressure through the reduced pressure conduit **112** to the breathable interface systems **100**, **200**, **500**, and **600**. The aperture **302** may be a single aperture as shown, or any number or plurality of holes, openings, apertures, slits, or the like desirable for providing distribution of reduced pressure and fluid transmission between the tissue site and the first pad section **102**, second pad section **104**, and fabric layer **106**. As described above, the first pad section **102** and second pad section **104** may include pathways or channels that permit the reduced pressure to be distributed throughout the breathable interface systems **100**, **200**, **500**, and **600**, and that permit fluids to be removed from a tissue site through the aperture **302**. The weave or mesh structure of the fabric layer **106** provides additional fluid pathways that are less susceptible to collapsing under compressive loads that may be applied to the breathable interface systems **100**, **200**, **500**, and **600**, such as those encountered when a patient rolls in bed or otherwise moves causing compression of the dressing. The additional fluid pathways also reduce the time required to distribute reduced pressure to a tissue site. As detailed below, testing has shown that pressure changes by a reduced pressure source are communicated to the tissue site much more quickly with a dressing configured like that of the breathable interface systems **100**, **200**, **500**, and **600**.

Referring to FIG. 7, an illustrative embodiment of a reduced pressure tissue treatment system **700** incorporating the novel features of the breathable interface system is shown. The reduced pressure tissue treatment system **700** includes a breathable interface system **701** similar to the other breathable interface system described herein, which is applied to a tissue site **702** for treatment. Breathable interface system **100** is fluidly connected to a reduced pressure source **704** by a reduced pressure conduit **112**. In certain embodiments, the reduced pressure tissue treatment system **700** may also include a canister **706** for collecting fluid and other non-gaseous exudates extracted from the tissue site **702**.

Referring to FIG. 8, a chart that compares the results of pressure transmission tests on a conventional dressing and a breathable interface system **100** as substantially described above is shown. In the tests, reduced pressure was applied to and water was pumped through each breathable interface system **100** while the breathable interface system **100** was subjected to a range of compressive forces. Pressure measurements were taken on both sides of the compressive forces to determine the performance of each specimen. The results, as shown in FIG. 8, demonstrate that a breathable interface system **100** as described above enables pressure communication across the compressive load to a much greater extent than a conventional dressing.

The flow of water was set to approximately 20 ml/hr and a compressive force from approximately 0 N to about 500-930 N was applied to the conventional dressing and the breathable interface system **100**. The y-axis **802** represents the amount of reduced pressure or vacuum measured at either the pump or the dressing/breathable interface system **100**. The x-axis **804** represents the duration of time expired from the start of the tests. Line **806** represents the magnitude of the reduced pressure at the pump for the conventional dressing and the line **808** represents the magnitude of the reduced pressure at the opposite side of the dressing. As can be seen from FIG. 8, a compressive force of approximately 900 N was applied to the conventional dressing and the amount of measurable reduced pressure was approximately 0 mm Hg. at the dressing, as shown by line **808**. At the start of event **814**, the compressive force was released, thus the amount of measurable reduced pressure at the dressing increased to approximately 120 mm Hg. At the end of event **814**, a compressive force was applied at a magnitude of 525 N and the amount of measurable reduced pressure dropped back to approximately 0 mm Hg. During this same event, the measurable reduced pressure at the pump side of the dressing, as shown by line **806**, stayed at approximately 125 mm Hg. This shows that with a conventional dressing under compressive force, the amount of reduced pressure through the dressing is approximately 0 mm Hg. Similarly, at events **816**, **818**, and **820**, compressive forces were released and reapplied at approximately 250 N. It can be seen from FIG. 8, that essentially the same results followed. Namely, as soon as a compressive force was applied, the measurable amount of reduced pressure through the conventional dressing dropped to 0 mm Hg, or near 0 mm Hg.

Conversely, line **810** represents the magnitude of the reduced pressure at the pump for the breathable interface system **100** and the line **812** represents the magnitude of the reduced pressure at the opposite side of the dressing. As described above, a compressive force of approximately 900 N was applied to the conventional dressing and the amount of measurable reduced pressure was approximately 50 mm Hg at the dressing, as shown by line **812**. At the start of event **814**, the compressive force was released, thus the amount of measurable reduced pressure at the dressing increased to approximately 120 mm Hg. At the end of event **814**, a compressive force was applied at a magnitude of 525 N and the amount of measurable reduced pressure was reduced to approximately 50 mm Hg. During this same event, the measurable reduced pressure at the pump side of the dressing, as shown by line **810**, stayed at approximately 125 mm Hg. This shows that with a breathable interface system **100** under compressive force, the amount of reduced pressure is still substantial. Similarly, at events **816**, **818**, and **820**, compressive forces were released and reapplied at approximately 250 N. It can be seen from FIG. 8, that even better results followed. Namely, as soon as a compressive force of approximately 250 N was applied, the measurable amount of reduced pressure through the conventional dressing increased to between approximately 70 mm Hg and 100 mm Hg.

Referring to FIG. 9, another chart is shown that compares response times of a conventional dressing and a breathable interface system **100** as substantially described above in FIG. 8 when subjected to intermittent application of reduced pressure under dry conditions. The response times illustrated in FIG. 9 demonstrate that a conventional dressing responds much more slowly than the breathable interface system **100** described above when subjected to these conditions.

Pressure measurements were taken on both sides of the compressive forces to determine the response times of a conventional dressing compared with the breathable interface system **100** described above. The results, as shown in FIG. **9**, demonstrate that a breathable interface system **100** as described above enables faster response times to the intermittent application and release of reduced pressure. The y-axis **902** represents the amount of reduced pressure or vacuum measured at either the pump or the dressing/breathable interface system **100**. The x-axis **904** represents the duration of time expired from the start of the tests. Line **906** represents the magnitude of the reduced pressure measured at the pump for the conventional dressing and the line **908** represents the magnitude of the reduced pressure at the opposite side of the dressing. Line **910** represents the magnitude of the reduced pressure measured at the pump for the breathable interface system **100** and the line **912** represents the magnitude of the reduced pressure measured at the opposite side of the breathable interface system **100**.

As can be seen from FIG. **9**, a reduced pressure is cycled on and off between approximately 0 mm Hg and 125 mm Hg. The lines **906** and **910** fairly closely match each other showing that there is little difference of measurable reduced pressure during the tests at the pump side of the dressing/breathable interface system **100** during the cycling of the reduced pressure. At the other side of the dressing, line **908** shows a lag time in achieving the applied reduced pressure at the conventional dressing. This can be seen as line **908** has an arc to its shape representing the gradual building of reduced pressure before it attains full reduced pressure. Conversely, line **912** shows sharp transitions when the reduced pressure is cycled on and off, thus representing that the breathable interface system **100** provides for improved fluid transmission and response to reduced pressure than conventional dressings.

It should be apparent from the foregoing that an invention having significant advantages has been provided. While the invention is shown in only a few of its forms, it is not just limited but is susceptible to various changes and modifications without departing from the spirit thereof.

We claim:

1. A dressing for treating tissue comprising:
an applicator having a proximal end with an aperture adapted to provide negative pressure to the tissue and having a distal end;
a porous pad formed from multi-components and substantially covering the aperture and extending proximate to the distal end of the applicator for receiving a reduced pressure from a conduit;
a drape substantially covering the porous pad and the applicator; and
a fabric layer located between the porous pad and the drape, wherein the drape is sealed to the applicator to substantially enclose the porous pad and the fabric layer.
2. The dressing of claim 1, wherein the porous pad is multilayered.
3. The dressing of claim 2, wherein one layer of the multilayered porous pad is disposed adjacent the fabric layer.
4. The dressing of claim 1, wherein the applicator is formed from a flexible material having a sufficiently high moisture vapor transmission rate.
5. The dressing of claim 1, further comprising an interface located between the conduit and at least one of the porous pad and the fabric layer.

6. The dressing of claim 1, wherein the porous pad is selected from the group consisting of open-cell reticulated foam, sintered polymers, ethylene vinyl acetate, fluoropolymers, polyurethane, polyolefin, vinyl acetate, polyvinyl alcohol, and their copolymers.

7. The dressing of claim 1, wherein the fabric layer is selected from the group consisting of woven fabric, non-woven fabric, polyamide, nylon, polyamide coated with polyurethane, polymeric meshes, non-woven melt blown polymers, and flexible sintered polymers.

8. The dressing of claim 1, wherein the fabric layer includes several overlapping layers joined together.

9. A method for treating tissue utilizing a dressing comprising:

an applicator having a first end including an aperture adapted to provide negative pressure to the tissue and having a second end;

a porous pad;

a fabric layer having a first end located adjacent the aperture between the porous pad and the applicator, the fabric layer having a second end extending proximate to the second end of the applicator for receiving a reduced pressure from a conduit; and

a drape sealed to the applicator and substantially enclosing the porous pad and the fabric layer;

the method comprising:

placing foam adjacent the tissue;

positioning the applicator over the foam with the aperture positioned adjacent the foam in fluid communication with the first end of the fabric layer;

sealing the applicator over the foam and the tissue; and providing reduced pressure to the conduit and the second end of the fabric layer such that fluids flow from the foam and through the fabric layer to the conduit.

10. The method of claim 9, further comprising covering the dressing over the foam and the tissue.

11. The method of claim 9, wherein the fluids flow through the fabric layer and the porous pad.

12. A method for treating tissue utilizing a dressing comprising:

an applicator having a proximal end with an aperture adapted to provide negative pressure to the tissue and having a distal end;

a porous pad substantially covering the aperture and extending proximate to the distal end of the applicator for receiving a reduced pressure from a conduit;

a drape substantially covering the porous pad and the applicator; and

a fabric layer located between the porous pad and the drape, wherein the drape is sealed to the applicator to substantially enclose the porous pad and the fabric layer;

the method comprising:

placing foam adjacent the tissue;

positioning the applicator over the foam with the aperture positioned adjacent the foam in fluid communication with the porous pad;

sealing the applicator over the foam and the tissue; and providing reduced pressure to the conduit and the porous pad such that fluids flow from the foam and through the porous pad.

13. The method of claim 12, further comprising covering the dressing over the foam and the tissue.

14. The method of claim 12, wherein the fluids flow through the fabric layer and the porous pad.

15. A method for treating tissue utilizing a dressing comprising:

11

an applicator having a first end including an aperture adapted to provide negative pressure to the tissue and having a second end;

a porous pad;

a fabric layer having a first end located adjacent the aperture between the porous pad and the applicator, the fabric layer having a second end extending proximate to the second end of the applicator for receiving a reduced pressure from a conduit; and

a drape sealed to the applicator and substantially enclosing the porous pad and the fabric layer;

the method comprising:

placing foam adjacent the tissue;

positioning the applicator over the foam with the aperture positioned adjacent the foam in fluid communication with the first end of the fabric layer;

covering the dressing over the foam and the tissue; and providing reduced pressure to the conduit and the second end of the fabric layer such that fluids flow from the foam and through the fabric layer to the conduit.

16. The method of claim 15, wherein the fluids flow through the fabric layer and the porous pad.

17. A method for treating tissue utilizing a dressing comprising:

an applicator having a proximal end with an aperture adapted to provide negative pressure to the tissue and having a distal end;

a porous pad substantially covering the aperture and extending proximate to the distal end of the applicator for receiving a reduced pressure from a conduit;

a drape substantially covering the porous pad and the applicator; and

12

a fabric layer located between the porous pad and the drape, wherein the drape is sealed to the applicator to substantially enclose the porous pad and the fabric layer;

the method comprising:

placing foam adjacent the tissue;

positioning the applicator over the foam with the aperture positioned adjacent the foam in fluid communication with the porous pad;

covering the dressing over the foam and the tissue; and providing reduced pressure to the conduit and the porous pad such that fluids flow from the foam and through the porous pad to the conduit.

18. The method of claim 17, wherein the fluids flow through the porous pad and the fabric layer.

19. A dressing for treating tissue comprising:

an applicator having a proximal end with an aperture adapted to provide negative pressure to the tissue and having a distal end;

a porous pad substantially covering the aperture and extending proximate to the distal end of the applicator for receiving a reduced pressure from a conduit;

a drape formed from a flexible material having a sufficiently high moisture vapor transmission rate and substantially covering the porous pad and the applicator; and

a fabric layer located between the porous pad and the drape, wherein the drape is sealed to the applicator to substantially enclose the porous pad and the fabric layer.

* * * * *