

(No Model.)

F. B. LOTZE.

MACHINE FOR LAP SEAMING SHEET METAL TUBES.

No. 524,554.

Patented Aug. 14, 1894.

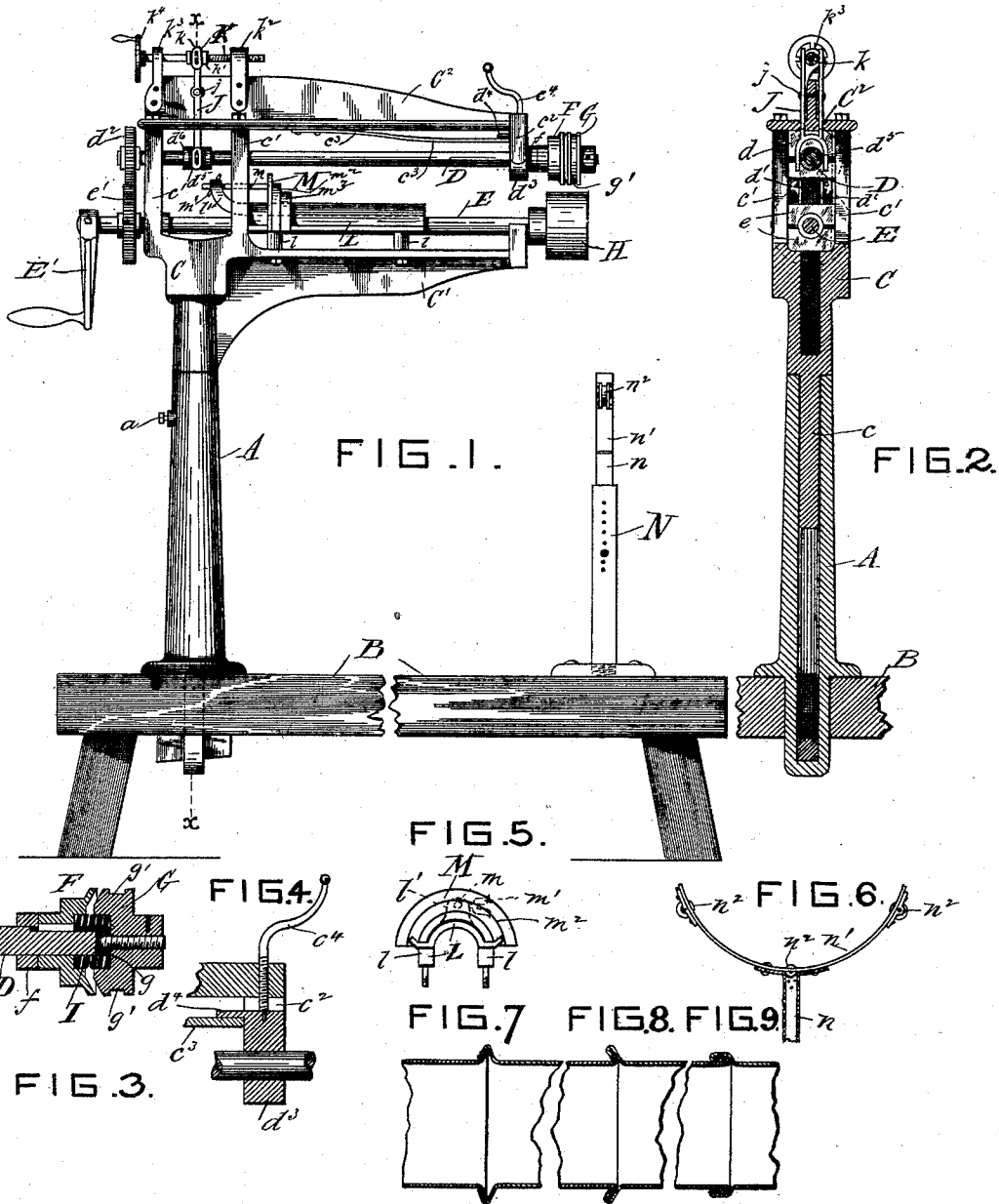

Witnesses:  
Frank S. Davis  
Emma Lyford

Inventor:  
Frederick B. Lotze  
By Geo. Murray

# UNITED STATES PATENT OFFICE.

FREDERICK B. LOTZE, OF AVONDALE, OHIO.

## MACHINE FOR LAP-SEAMING SHEET-METAL TUBES.

SPECIFICATION forming part of Letters Patent No. 524,554, dated August 14, 1894.

Application filed December 16, 1893. Serial No. 493,831. (No model.)

*To all whom it may concern:*

Be it known that I, FREDERICK B. LOTZE, a citizen of the United States, and a resident of Avondale, in the county of Hamilton and State of Ohio, have invented certain new and useful Improvements in Machines for Lap-Seaming Sheet-Metal Tubes, of which the following is a specification.

The object of my invention is a machine for joining by lap seams sections of sheet metal tubes and especially such as are employed for the hot air pipes of furnaces.

The invention will be first fully described in connection with the accompanying drawings, and then particularly referred to and pointed out in the claims.

Referring to the drawings in which like parts are indicated by similar reference letters wherever they occur throughout the various views—Figure 1 is a side elevation of a machine embodying my improvements. Fig. 2 is a vertical section of the same through line *x, x*, Fig. 1 looking to the left. Fig. 3 is a detail view in axial section upon an enlarged scale of the seam forming wheels. Fig. 4 is a detail view in vertical section of the front and end of the upper bracket arm and bearing for the forming wheels shaft. Fig. 5 is a front elevation of the gage and support for the inner end of the tube while the seam is being formed. Fig. 6 is a detail view in edge elevation of the bearing or rest for the opposite end of the tube. Figs. 7, 8 and 9 are sectional views of a portion of the tube illustrating the different steps in forming the joint or seam which unites the sections.

The head stock of the machine is mounted in a hollow column A, which is secured in any suitable manner upon the stand B, the head stock C, has a diminished shank *c*, which enters the bore of the column A, and is held rigidly in position by a set screw *a*. From one side of the head stock C, projects a bracket C', and on top of the head stock is a similar bracket C<sup>2</sup>, these brackets furnish the supports for the outer bearings of the shafts D. and E, the upper one D, carrying the forming wheels F. and G. and the lower one carrying the plain anvil wheel H, the rear bearings *d*, and *e*, for the shafts D. and E. having their edges grooved to fit the "V" shaped bearings in the rear upright *c'*, of the head stock C, the

upper box of the bearing *e*, and the lower box of the bearing *d*, being united by rods *d'*. The shafts D. and E. are geared together by the cog wheels *e'*, and *d<sup>2</sup>*; which are secured upon the rear ends of the shafts D, and E.

The bearings for the shaft E, are fixed, while the front bearing *d<sup>3</sup>*, of the shaft D, is arranged to slide vertically between lugs *c<sup>2</sup>*, which project downwardly from the forward end of the bracket arm C<sup>2</sup>, the bearing has an inwardly projecting lug *d<sup>4</sup>*, to overlap the end of the spring *c<sup>3</sup>*, which is secured underneath the arm C<sup>2</sup>, the pressure of the spring being upward.

Tapped in the forward end of arm C<sup>2</sup>, is a tail screw *c<sup>4</sup>*, the diminished lower end of which enters the perforation in the bearing *d<sup>3</sup>*, by means of this screw the bearing is forced downwardly to bring the wheels F. and G. in the direction of the wheel H, when the screw *c<sup>4</sup>*, is turned backward the spring *c<sup>3</sup>*, forces the bearing up and separates the seam forming wheels.

The adjacent faces of the seam forming wheels F, and G, are formed the one counter to the other, the face of the wheel F, being dished or concave, the opposite face of the wheel G, is convex or beveled counter to the inwardly inclined bevel of the wheel F. The wheel G, is secured upon the end of the shaft D. As shown the end of the shaft is screw threaded and the wheel G, tapped and screwed up tightly against the washer *g*, the screw being a left hand one so that in use the tendency is to tighten the wheel upon the shaft. The wheel F, is splined upon the shaft D, and the bore of both wheels is enlarged to receive a strong spiral spring I, the office of which is to hold the wheel F, firmly against the collar *f*, when the shaft is forced forward in its bearing to separate the wheels F and G.

The shaft D is arranged to slide longitudinally in its bearings for the purpose of forcing the wheel G, away from the wheel F, or drawing it nearer to said wheel F. The shaft D, is moved longitudinally by a lever J, the opposite ends of which are coupled to loose collars *d<sup>5</sup>*, and *k*, which are held respectively on the shafts D, and K, between fixed collars *d<sup>6</sup>*, and *k'*, the arms of the lever pass through slots in the horizontal web or bracket arm C<sup>2</sup>, and are fulcrumed to the ver-

tical web by the fulcrum pin *j*. The inner end of the screw shaft *K*, is tapped into a bearing *k*<sup>2</sup>, secured upon the vertical web of the arm *C*<sup>2</sup>, and the plain portion of the shaft  
 5 passes through a bearing *k*<sup>3</sup>, which is also secured to the vertical web of the arm *C*<sup>3</sup>. The shaft is fitted with a hand wheel *k*<sup>4</sup>, by which the lever is actuated to move the shaft *D*, in its bearings to separate the wheels *F*, and *G*,  
 10 or bring them together.

Upon the bracket *C*<sup>1</sup>, is a curved bed plate *L*. Its downwardly projecting lugs *l*, pass through the flange of the bracket and have their diminished ends screw threaded to receive nuts to  
 15 hold the bed plate firmly in position. The center of the bed plate arches over the shaft *E*. Upon this bed plate is fitted to slide a gage *M*, which is formed of segments of different diameters and has a rearwardly projecting rod *m*, which passes through the arm  
 20 *l*<sup>1</sup>, which projects up from the bed plate and has a set screw *m*<sup>1</sup>, to hold the gage *M*, in any desired position on the bed plate. The purpose of the rod *m*, and set screw *m*<sup>1</sup>, is to  
 25 adjust the gage to the different lengths of tubes which are to be united.

Secured upon the stand *B*, is a hollow column *N*, and *n*, is a shaft of a yoke *n*<sup>1</sup>, which shaft fits into the hollow column *N*, and is  
 30 vertically adjustable by means of perforations passing through both the column and the shaft to receive a pin by which the yoke is elevated or lowered, the yoke *n*<sup>1</sup>, is fitted with vulcanite or fiber friction wheels *n*<sup>2</sup>,  
 35 upon which the tube rests. There are different sizes of these yokes to accommodate the different sizes of tubes to be seamed or united upon the machine.

The operation of the machine is as follows:—Two sections of tube to be united,  
 40 having had their opposite ends formed by the machines now in common use, are placed together as shown in Fig. 7, the two parts are then placed in position to be operated upon  
 45 by the machine, the inner end of one tube resting upon the larger segment *m*<sup>2</sup>, and the opposite end resting in the support *n*<sup>1</sup>. The wheels *F*, and *G*, are separated sufficiently to permit the bead on the end of the tube to  
 50 pass between them, the wheels *F*, and *G*, are then brought down upon the wheel *H*, wheels *F*, and *G*, are then brought together by turning the small hand wheel *k*<sup>4</sup>, until the parts embraced by the wheels are brought together  
 55 as shown in Fig. 8. The shafts *D*, and *E*, are then revolved by the crank *E*<sup>1</sup>, revolving the tubes at the same time and closing the joints entirely around at an inclination to the axis of the tube as seen in Fig. 8. The wheels *F*, and *G*, are then separated and elevated by  
 60 means of the tail screw *c*<sup>4</sup>. The inner end of the tube is then placed upon the smaller segment *m*<sup>3</sup>, and the grooved portion *g*<sup>1</sup>, of the wheel brought over the inclined seam of the tube, the wheel *G*, is then brought down over the inclined seam pressing it down flat as  
 65 seen in Fig. 9, then by revolving the crank

*E*<sup>1</sup>, the seam is flattened down and the joint completed.

It is obvious that the column *A*, head stock  
 70 *C*, and the brackets *C*<sup>1</sup>, and *C*<sup>2</sup>, may be cast in a single piece, and that many other merely mechanical changes may be made in the device without departing from the spirit and  
 75 scope of my invention.

What I claim, and desire to secure by Letters Patent, is—

1. In a tube seaming machine the combination of the supporting column, the head stock having fixed brackets projecting laterally  
 80 from one side thereof, and parallel with each other, the parallel shafts *D*, *E*, mounted in said head stock the said shaft *D*, being adjustable longitudinally in its bearing and at its forward  
 85 end to and from the shaft *E*, the cog wheels gearing the shafts together, the plain wheel *H*, on the end of shaft *E*, the forming wheels *F*, and *G*, on the end of shaft *D*, said wheel *G*, being fixed to move longitudinally with the shaft and the wheel *F*, splined to permit  
 90 the shaft to move longitudinally through it, and means such as shown to move the shaft *D*, longitudinally in its bearings and vertically to close and separate the seam forming wheels *F*, *G*, *H*.  
 95

2. The combination of the head stock, the fixed shaft *E*, having wheel *H*, secured thereon the longitudinal adjustable shaft *D*, mounted in said head stock parallel with shaft *E*, and above it, the cog wheels *e*<sup>1</sup>, *d*<sup>2</sup>,  
 100 gearing the shafts together, said shaft *D*, being longitudinally adjustable in its bearings and its forward end vertically adjustable in relation to wheel *H*, the wheel *G*, grooved around its periphery and beveled upon its  
 105 inner face said wheel being secured upon the end of the shaft *E*, and the wheel *F*, having its face concave and splined upon shaft *D*, the bearing *d*<sup>3</sup>, of the outer end of the shaft *D*, fitted to slide vertically in the head stock,  
 110 the screw shaft *K*, the lever *L*, fulcrumed in the head stock and connected to shafts *K*, and *D*, to move the shaft *D*, longitudinally in its bearings and the tail screw *c*<sup>4</sup>, to adjust the forming wheels to or from the wheel *H*,  
 115 substantially as shown and described.

3. The combination of the head stock the parallel shafts mounted therein, one of said shafts being fixed and the other one movable, the wheel *H*, mounted upon the fixed shaft  
 120 and the wheels *F*, *G*, upon the movable shaft, the bearing *d*<sup>3</sup>, fitted to slide in the head stock, the tail screw for forcing the bearing down and bringing the forming wheels in the direction of the wheel *H*, the spring *c*<sup>3</sup>, to force  
 125 the bearing up when the tail screw is reversed, the bed plate *L*, and the adjustable segmental bearing *M*, fitted to slide upon the bed plate *L*, and support the inner end of the tube while the seam is being formed, substantially  
 130 as shown and described.

4. The combination substantially as hereinbefore set forth in a tube seaming machine, of a pair of seam forming rolls, having their

adjacent faces inclined in relation with their axes and movable to and from each other for the purpose of uniting the opposite ends of two tube sections, and inclining the partially  
5 formed seam at an angle to the tube, one of said rolls having a grooved periphery counter to the ridge formed by the completed seam for the purpose set forth.

10 5. The combination of the shafts D, E, geared together, the rolls F, G, H, on the ends of said shafts, the bed plate L, and the segmental support M, adjustable upon said bed plate, substantially as shown and described.

6. The combination of the stand, the sup-

porting column and head stock mounted 15 thereon and said head stock having laterally projecting brackets upon one side, the parallel shafts carrying seam forming wheels mounted in said head stock and brackets, and the vertically adjustable support N, n, n', 20 resting upon said stand in front of the forming wheels to support one section of the tube while the seam is being formed substantially as shown and described.

FREDERICK B. LOTZE.

Witnesses:

FRANK S. DAVIS,  
GEO. J. MURRAY.