



- (51) **International Patent Classification:**
B21D 51/18 (2006.01) A47G 19/22 (2006.01)
- (21) **International Application Number:**
PCT/CN2016/070493
- (22) **International Filing Date:**
8 January 2016 (08.01.2016)
- (25) **Filing Language:** English
- (26) **Publication Language:** English
- (30) **Priority Data:**
201510297012.X 30 May 2015 (30.05.2015) CN
- (71) **Applicant:** PPI WORLDWIDE GROUP(HK) LIMITED [CN/CN]; Room 1021 Sun Hung Kai Centre, 30 Harbour Road, Wanchai, Hong Kong 999077 (CN).
- (72) **Inventor:** MA, Jianting; Room 703, No.655, Zhongxing Road, Jiangdong District, Ningbo, Zhejiang 315000 (CN).
- (74) **Agent:** CHOFN INTELLECTUAL PROPERTY; Room 1215-1218, Floor 12 Left Bank Community No.68 Beisihuanxilu, Haidian District, Beijing 100080 (CN).
- (81) **Designated States** (unless otherwise indicated, for every kind of national protection available): AE, AG, AL, AM, AO, AT, AU, AZ, BA, BB, BG, BH, BN, BR, BW, BY,

BZ, CA, CH, CL, CN, CO, CR, CU, CZ, DE, DK, DM, DO, DZ, EC, EE, EG, ES, FI, GB, GD, GE, GH, GM, GT, HN, HR, HU, ID, IL, IN, IR, IS, JP, KE, KG, KN, KP, KR, KZ, LA, LC, LK, LR, LS, LU, LY, MA, MD, ME, MG, MK, MN, MW, MX, MY, MZ, NA, NG, NI, NO, NZ, OM, PA, PE, PG, PH, PL, PT, QA, RO, RS, RU, RW, SA, SC, SD, SE, SG, SK, SL, SM, ST, SV, SY, TH, TJ, TM, TN, TR, TT, TZ, UA, UG, US, UZ, VC, VN, ZA, ZM, ZW.

- (84) **Designated States** (unless otherwise indicated, for every kind of regional protection available): ARIPO (BW, GH, GM, KE, LR, LS, MW, MZ, NA, RW, SD, SL, ST, SZ, TZ, UG, ZM, ZW), Eurasian (AM, AZ, BY, KG, KZ, RU, TJ, TM), European (AL, AT, BE, BG, CH, CY, CZ, DE, DK, EE, ES, FI, FR, GB, GR, HR, HU, IE, IS, IT, LT, LU, LV, MC, MK, MT, NL, NO, PL, PT, RO, RS, SE, SI, SK, SM, TR), OAPI (BF, BJ, CF, CG, CI, CM, GA, GN, GQ, GW, KM, ML, MR, NE, SN, TD, TG).

Declarations under Rule 4.17:

- as to the applicant's entitlement to claim the priority of the earlier application (Rule 4.17(iii))

Published:

- with international search report (Art. 21(3))

(54) **Title:** IRREGULAR ALUMINUM CUP AND METHOD FOR MANUFACTURING THE SAME



图 1

(57) **Abstract:** An irregular aluminum cup sequentially comprises from bottom to mouth: a cylinder cup bottom (1), a cup body with printing patterns on an exterior surface thereof and having one or more concave body parts (2) and one or more convex body parts (3), with the concave body parts and convex body parts alternately arranged; and a cup mouth (4) having an edge (5) curled outwards and towards the cup body arranged at the top of the mouth; the cup bottom, the cup body and the cup mouth are of an integral structure. A method is provided for manufacturing the above irregular aluminum cup. The irregular aluminum cup can have various shapes and maintain the design printing.

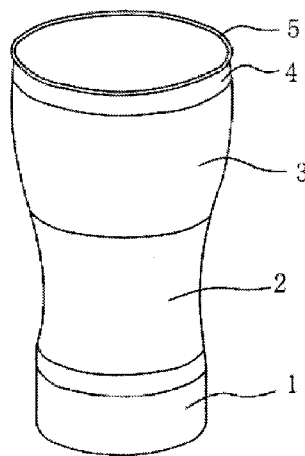

Irregular aluminum cup and method for manufacturing the same

Technical Field

The invention relates to an irregular aluminum cup and a method for manufacturing the same.

Background Art

Currently, normal aluminum cups available in the market all have a single shape, that is, all aluminum cups are cylindrical- or truncated conical-shaped (with a larger mouth and a smaller bottom) obtained by processing straight cylinders via stretching or trumpet-shaped obtained by spin processing. Aluminum cups with the above shapes can hardly meet various life-style requirements of modern life. A cylindrical shaped aluminum cups is simple and can only have a same diameter for both the bottom and the mouth. A truncated conical shaped aluminum cup is similar to a cylindrical one, also having a straight cup body though with a bottom diameter smaller than a mouth diameter. The only advantage of cylindrical and truncated conical aluminum cups as well as spin formed trumpet-shaped aluminum cups lies in that they allow print on cup bodies to be freely designed and selected, as printing on straight bodies is not limited by printing processes. Although the spin formed trumpet-shaped aluminum cup generally has a form with a smaller bottom and a larger mouth, it also has the following obvious disadvantages. First of all, due to the effect of its surface curve, reprocessing of an aluminum cup body surface cannot be done through overall printing; instead, small-area processing such as local printing in a smaller range is used. Secondly, due to the limit of spinning process, during the bottom-to-mouth processing and extending of the spin formed aluminum cup, the diameter of the finished product increases all the way up, making it impossible to produce an aluminum cup with a shape having a concave central part or one with a convex central part and a recessed mouth. That is to say, diameters of different parts of an aluminum cup, from the bottom to the mouth, are gradually increased, which is irreversible so as to decrease the diameter. Moreover, any aluminum cup having recessed central part made from other conventional methods cannot have a convex body part with a diameter larger than that of the bottom.

Moreover, conventional processes for manufacturing aluminum cups are classified into spinning or stamping. Spinning processes an aluminum blank with a tool or a die during high speed spinning of the aluminum blank, and is used mostly for producing aluminum cups with curved wall. Stamping performs one or more stretching by using a stamping machine to form the shape of an aluminum cup, normally with a straight body. The surface of the formed aluminum cups is then spray painted or oxidized, followed by small-area

printing to decorate the cups. The above two conventional processes have the following disadvantages.

1. Aluminum cups made through spinning and stamping processes can only have a diameter increased gradually from the bottom to the month, with no concave central part. In this sense, the two conventional processes can only produce simple shaped aluminum cups.
2. Conventional processes and technologies make it impossible to print all-over the finished products.
3. The conventional processes are of higher cost, while the efficiency of production is significantly limited by available equipment and manpower, making it difficult to be adapted to large scale automated production.

Disclosure of the Invention

In order to overcome the above disadvantages, the invention provides an irregular cup and a method for manufacturing the same. The irregular cup of the invention can have various shapes and completely maintain an appearance print design thereof.

An aspect of the invention provides an irregular aluminum cup, which comprises sequentially from bottom to mouth:

a cylindrical cup bottom,

a cup body with printing patterns on an exterior surface thereof and having one or more concave body parts and one or more convex body parts, with the concave body parts and convex body parts alternately arranged; and

a cup month having an edge curled outwardly and towards the cup body arranged at the top of the cup mouth;

wherein the cup bottom, the cup body and the cup mouth are of an integral structure.

Furthermore, the cup body has printing patterns on the whole exterior surface thereof.

Optionally, the printing patterns have one to nine colors.

Optionally, a diameter of a concave body part is equal to or larger than 70% that of the cup bottom.

Optionally, a diameter a convex body part is smaller than or equal to 1.5 times that of the cup bottom.

Optionally, the cup month is a convex mouth or a concave mouth.

Preferably, the cup body comprises sequentially a concave lower body part and a convex upper body part, and the cup mouth is a concave mouth.

Preferably, the cup bottom, the concave body part, the convex body part, the concave cup mouth and the curled edge are of an integral structure.

Another aspect of the invention provides a method for manufacturing the above irregular aluminum cup, the method comprises the following steps:

- a. preprinting patterns on a pre-formed cylindrical aluminum cup blank;
- b. forming the cup body comprising a concave body part and/or a convex body part; and
- c. forming the cup mouth by necking or expanding, multiple times, an expanded or necked upper part of the cup body via a necking process or an expanding process, a cup diameter being decreased or increased each time, and then curling the cup mouth via a stamping process.

Furthermore, the pre-formed cylindrical aluminum cup blank is formed by cold extruding an aluminum block and spraying a protection coating onto an inner wall of the aluminum cup blank via an internal coating machine, and preprinting patterns on an exterior surface of the aluminum cup blank is done via an offset printing press with 1 to 9 colors, the preprinted patterns are scaled or stretched as needed in advance.

Furthermore, the forming the concave body part (2) of step b comprises necking the body part through multiple processes by decreasing the cup diameter each time through a multistation flexible necking process; and the forming convex body part (3) of step b comprises expanding the body part through multiple processes by increasing the cup diameter each time through a multistation rigid expanding process.

Optionally, in steps b and c, a deformation quantity of the cup diameter in each step is less than or equal to 4 mm.

The irregular aluminum cup of and the method for manufacturing the same as provided by the invention have at least one of the following beneficial effects:

1. The aluminum cup may have various shapes. As the necking and expanding may be performed through several stages, the maximum diameter of the cup body may be increased to 1.5 times that of the cup bottom. The cups may have various shapes, depending on different degrees of necking and expanding.
2. Printing on the exterior surface has rich decorative colors, which overcomes the difficulty faced by curved surface printing. The inventive process of the invention performs printing before formation, and the preprinted patterns on the surface of the cups are sufficiently protected during the formation. The problem of the formed curved cup body being

difficult to be printed on large area or as a whole in the conventional processes is thereby overcome.

3. The inventive aluminum cup and method for manufacturing the same fits for high-speed automated production, which improves the production efficiency. The related apparatuses are modified accordingly to make it fit for high-speed automated production. The conventional technology which works only on a single machine and has to be realized through multiple stages of production is improved and integrated into a technology suitable for full-automation. The production efficiency is expected to be highly increased compared to the conventional technologies.
4. The product cost is reduced as losses caused by the multiple stages of production of the conventional technology is reduced, with the improvement and integration of the production processes. With the improvement in the production efficiency, the overall production cost is reduced.

Description of Drawings

The invention will be described in more detail in the following with reference to figures, of which:

Figure 1 is a three-dimensional schematic diagram of an irregular aluminum cup according to an embodiment of the invention;

Figure 2 schematically illustrates a cross section of a cylindrical aluminum cup blank at step a;

Figure 3 schematically illustrates a diagram of the aluminum cup blank after a concave cup part is formed at step b;

Figure 4 schematically illustrates a diagram of the aluminum cup blank after a concave cup part and a convex cup part are formed at step b; and

Figure 5 schematically illustrates a diagram of the aluminum cup blank at step c.

Numerical References:

1-cup bottom; 2-concave cup part; 3-convex cup part; 4-cup mouth, 5-cured edge

Detailed Description of Embodiments

In order to make objects, technical details and advantages of the embodiments of the invention apparent, the technical solutions of the embodiment will be described in a clearly and fully understandable way in connection with the drawings related to the embodiments of the invention. It is obvious that the described embodiments are just a part but not all of the

embodiments of the invention. Based on the described embodiments herein, those skilled in the art can obtain other embodiment(s), without any inventive work, which should be within the scope of the invention.

An aspect of the invention provides an irregular aluminum cup, which comprises sequentially from bottom to mouth:

a cylindrical cup bottom 1,

a cup body with printing patterns on an exterior surface thereof and having one or more concave body parts 2 and one or more convex body parts 3, the concave body parts 2 and convex body parts 3 are alternately arranged; and

a cup mouth 4 having an edge 5 curled outwardly and towards the cup body arranged at the top of the mouth;

wherein the cup bottom 1, the cup body and the cup mouth 4 are of an integral structure.

The cup body has printing patterns on the whole exterior surface thereof, and the printing patterns have one to nine colors.

A diameter of a concave body part 2 is equal to or larger than 70% that of the cup bottom 1; and a diameter of a convex body 3 part is smaller than or equal to 1.5 times that of the cup bottom 1.

The cup mouth 4 is a convex mouth or a concave mouth. When the cup body next to the cup mouth 4 is a concave body part 2, the cup mouth is a convex mouth 4; when the cup body next to the cup mouth 4 is a convex body part 3, the cup mouth is a concave mouth 4.

Embodiment:

Fig. 1 is a three-dimensional schematic diagram of an irregular aluminum cup according to an embodiment of the invention. With reference to Fig. 1, the embodiment of the invention provides an irregular aluminum cup, which comprises sequentially from bottom to mouth: a cylindrical cup bottom 1, a concave body part 2, a convex body part 3, and a concave cup mouth 4, an edge 5 curled outwardly and towards the cup body is arranged at the top of the mouth. The cup bottom 1, the concave body part 2, the convex body part 3, the cup mouth 4 and the curled edge 5 are of an integral structure.

Fig. 2 schematically illustrates a cross section of a cylindrical aluminum cup blank at step a. Fig. 3 schematically illustrates a diagram of the aluminum cup blank after a concave cup part is formed at step b. Fig. 4 schematically illustrates a diagram of the aluminum cup blank after a concave cup part and a convex cup part are formed at step b. Fig. 5 schematically illustrates a diagram of the aluminum cup blank at step c. With reference to Figs. 2 to 5, another aspect of the invention provides a method for manufacturing the above irregular aluminum cup, the method comprises the following steps:

- a. preprinting patterns on a pre-formed cylindrical aluminum cup blank (Fig. 2);
- b. forming the cup body comprising the concave body part 2 (Fig. 3) and/or the convex body part 3 (Fig. 4); and
- c. forming the cup mouth 4 by necking or expanding, multiple times, an expanded or necked upper part of the cup body via a necking process or an expanding process, a cup diameter being decreased or increased each time, and then curling the cup mouth 4 via a stamping process (Fig. 5).

It is noted that the invention may be realized by performing necking via a conventional apparatus capable of mechanical necking process and performing expanding via a conventional apparatus capable of mechanical expanding process. Alternatively, a necking-expanding machine capable of both necking and expanding processes may be used for the above necking and expanding. The necking-expanding machine is a machine has a cover die, onto which a required apparatus and mould may be loaded, such that a conventional apparatus only for necking may perform both necking and expanding. Moreover, the expanded diameter is larger than that of the bottom, thereby realizing high-speed production of aluminum cups and significantly reducing the production cost.

In the above step a, the pre-formed cylindrical aluminum cup blank is formed by cold extruding an aluminum block and spraying a protection coating onto an inner wall of the aluminum cup blank via an internal coating machine. Then preprinting patterns on an exterior surface of the aluminum cup blank is done via an offset printing press with 1 to 9 colors, the preprinted patterns are scaled or stretched as needed in advance.

In the above step b, the step of forming the concave body part 2 (see Fig. 3) comprises necking the body part through multiple processes by decreasing the diameter each time through a multistation flexible necking process. The concave shape is formed after multiple processes. The diameter of the concave body part 2 is obviously larger than that of the cup bottom; that is, the diameter of the concave body part 2 is equal to or larger than 70% that of the cup bottom 1.

The step of forming convex body part 3 (see Fig. 4) of step b comprises expanding the body part through multiple processes by increasing the diameter each time through a multistation rigid expanding process. The convex shape is formed after multiple processes. By multiple expanding processes, the maximum diameter of the cup body is increased to 1.5 times that of the cup bottom 1, while the preprocessed interior and exterior surfaces are not damages, thereby ensuring the interior surface being food-safe and the maintaining the decorative effect of the exterior surface.

Moreover, in steps b and c, a deformation quantity of the cup body diameter in each step is less than or equal to 4 mm, such that the already finished inner protection coating and exterior decorative printing will not be damaged. It also helps to prevent damages to the surface and internal crystalline structure of the cup body by too large a deformation quantity.

In summary, the cylindrical aluminum cup blank is eventually formed into a cup through multiple necking and expanding processes. The production processes of the invention not only meet the requirements of producing various-shaped products, but also intactly maintain the design printing on the product. Therefore, more attractive product meeting various requirements can be made.

The above is only the preferred embodiment of the invention and is not intended to limit the invention. For a person skilled in the art, the invention may have a variety of changes and modifications. Any change, equivalent replacement, improvement made within the spirit and principle of the present invention should be included in the protection scope of the invention

Claims:

1. An irregular aluminum cup, comprising sequentially from bottom to mouth:
a cylindrical cup bottom (1),
a cup body with printing patterns on an exterior surface thereof and having one or more concave body parts (2) and one or more convex body parts (3), with the concave body parts (2) and convex body parts (3) alternately arranged; and
a cup mouth (4) having an edge (5) curled outwardly and towards the cup body arranged at the top of the mouth (4);
wherein the cup bottom (1), the cup body and the cup mouth (4) are of an integral structure.
2. The irregular aluminum cup according to claim 1, wherein the cup body has printing patterns on the whole exterior surface thereof.
3. The irregular aluminum cup according to claim 1 or 2, wherein the printing patterns have one to nine colors.
4. The irregular aluminum cup according to claim 2, wherein a diameter of a concave body part (2) is equal to or larger than 70% that of the cup bottom (1).
5. The irregular aluminum cup according to claim 2 or 4, wherein a diameter of a convex body part (3) is smaller than or equal to 1.5 times that of the cup bottom (1).
6. The irregular aluminum cup according to claim 1, wherein the cup mouth (4) is a convex mouth or a concave mouth.
7. The irregular aluminum cup according to claim 6, wherein the cup body comprises sequentially a concave lower body part (2) and a convex upper body part (3), and the concave cup mouth (4) is a concave mouth.
8. The irregular aluminum cup according to claim 7, wherein the cup bottom (1), the concave body part (2), the convex body part (3), the cup mouth (4) and the curled edge (5) are of an integral structure.
9. A method for manufacturing an irregular aluminum cup of any of claims 1 to 8 comprising the following steps:
 - a. preprinting patterns on a pre-formed cylindrical aluminum cup blank;
 - b. forming the cup body comprising a concave body part (2) and/or a convex body part (3); and
 - c. forming the cup mouth (4) by necking or expanding, multiple times, an expanded or necked upper part of the cup body via a necking process or

an expanding process, a cup being decreased or increased each time, and then curling the cup mouth (4) via a stamping process.

10. The method for manufacturing an irregular aluminum cup according to claim 9, wherein the pre-formed cylindrical aluminum cup blank is formed by cold extruding an aluminum block and spraying a protection coating onto an inner wall of the aluminum cup blank via an internal coating machine, and preprinting patterns on an exterior surface of the aluminum cup blank is done via an offset printing press with 1 to 9 colors, the preprinted patterns are scaled or stretched as needed in advance.
11. The method for manufacturing an irregular aluminum cup according to claim 9 or 10, wherein:
 - the forming the concave body part (2) of step b comprises necking the body part through multiple processes by decreasing the cup diameter each time through a multistation flexible necking process;
 - the forming convex body part (3) of step b comprises expanding the body part through multiple processes by increasing the cup diameter each time through a multistation rigid expanding process.
12. The method for manufacturing an irregular aluminum cup according to claim 11, wherein in the steps b and c, a deformation quantity of the cup diameter in each step is less than or equal to 4 mm.



图 1



图 2

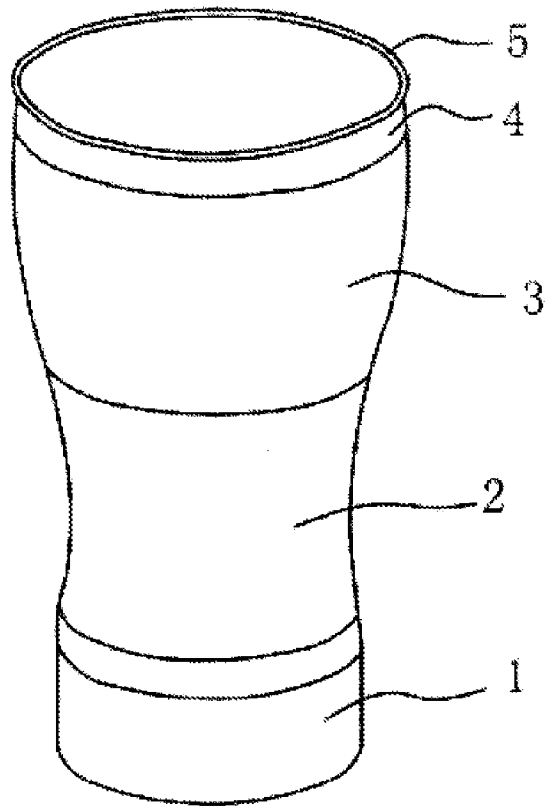

图 3

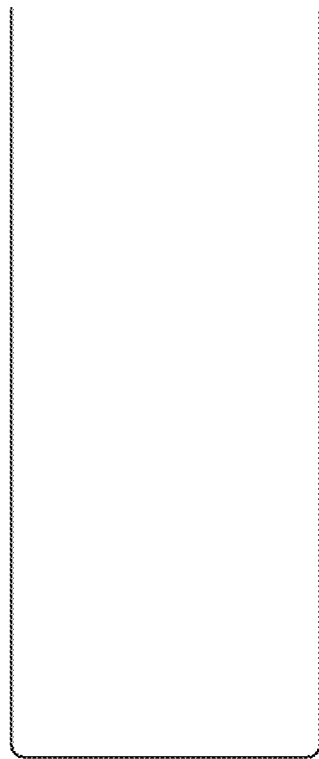

图 4

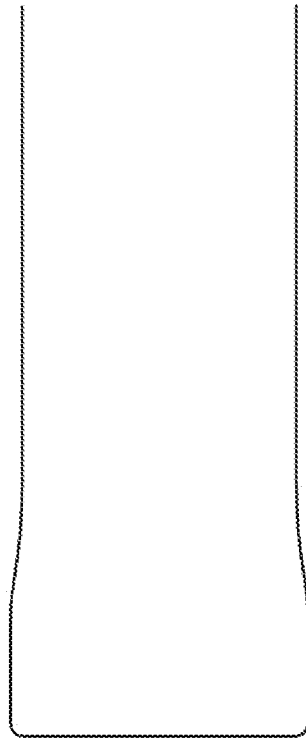

图 5

INTERNATIONAL SEARCH REPORT

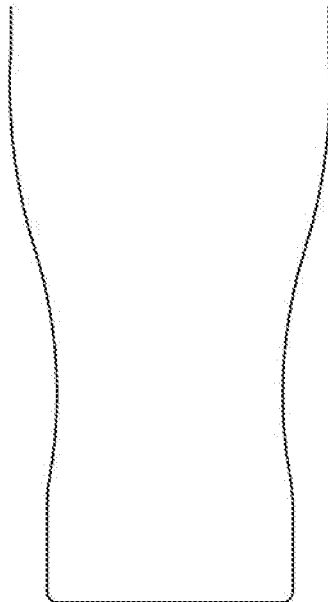
International application No.

PCT/CN2016/070493

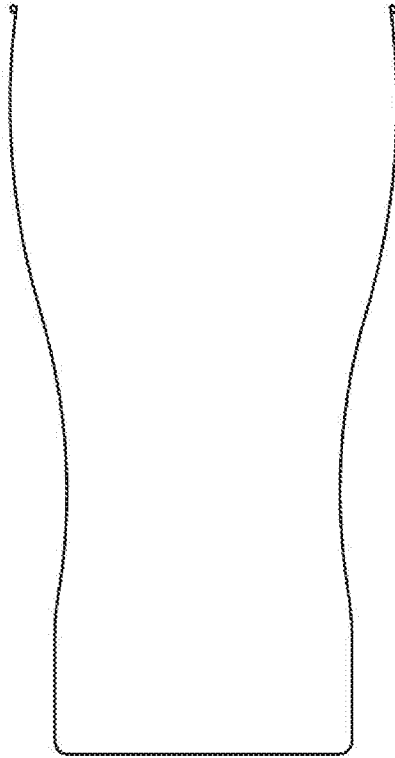
| A. CLASSIFICATION OF SUBJECT MATTER | | |
|--|---|--|
| B21D 51/18(2006.01)i; A47G 19/22(2006.01)i | | |
| According to International Patent Classification (IPC) or to both national classification and IPC | | |
| B. FIELDS SEARCHED | | |
| Minimum documentation searched (classification system followed by classification symbols) B21D,A47G19/22,B65D | | |
| Documentation searched other than minimum documentation to the extent that such documents are included in the fields searched | | |
| Electronic data base consulted during the international search (name of data base and, where practicable, search terms used) CNABS,CNKI,SIPOABS,VEN,cup, can, bottle, vessel, container, irregular, aluminum, concave, convex, necking, expand+ | | |
| C. DOCUMENTS CONSIDERED TO BE RELEVANT | | |
| Category* | Citation of document, with indication, where appropriate, of the relevant passages | Relevant to claim No. |
| PX | CN 104907451 A (NINGBO TONGXIANG IMPORT AND EXPORT CO., LTD.) 16 September 2015 (2015-09-16) See paragraphs [0005] to [0032] of the description and figures 1-5 | 1, 3-5, 7-10 |
| X | CN 101683913 A (EURO ASIA PACKAGING GUANGDONG) 31 March 2010 (2010-03-31) See description, page 3, line 7 to page 5, line 4 and figures 1-2 | 1-8 |
| Y | CN 101683913 A (EURO ASIA PACKAGING GUANGDONG) 31 March 2010 (2010-03-31) See description, page 3, line 7 to page 5, line 4 and figures 1-2 | 9-12 |
| Y | CN 103817259 A (SHANGHAI JIANGJIA AEROSOL CO LTD) 28 May 2014 (2014-05-28) See paragraphs [0033] to [0044] of the description and figures 1-6 | 9-12 |
| A | JP 2000015371 A (TAKEUCHI PRESS) 18 January 2000 (2000-01-18) See the whole document | 1-12 |
| A | CN 203698826 U (EURO ASIA PACKING GUANGDONG CO LID) 09 July 2014 (2014-07-09) See the whole document | 1-12 |
| A | WO 9932242 A1 (CROWN CORK & SEAL TECH CORPET AL.) 01 July 1999 (1999-07-01) See the whole document | 1-12 |
| <input type="checkbox"/> Further documents are listed in the continuation of Box C. <input checked="" type="checkbox"/> See patent family annex. | | |
| * Special categories of cited documents: | | |
| “A” | document defining the general state of the art which is not considered to be of particular relevance | “T” later document published after the international filing date or priority date and not in conflict with the application but cited to understand the principle or theory underlying the invention |
| “E” | earlier application or patent but published on or after the international filing date | “X” document of particular relevance; the claimed invention cannot be considered novel or cannot be considered to involve an inventive step when the document is taken alone |
| “L” | document which may throw doubts on priority claim(s) or which is cited to establish the publication date of another citation or other special reason (as specified) | “Y” document of particular relevance; the claimed invention cannot be considered to involve an inventive step when the document is combined with one or more other such documents, such combination being obvious to a person skilled in the art |
| “O” | document referring to an oral disclosure, use, exhibition or other means | “&” document member of the same patent family |
| “P” | document published prior to the international filing date but later than the priority date claimed | |
| Date of the actual completion of the international search | Date of mailing of the international search report | |
| 22 March 2016 | 22 April 2016 | |
| Name and mailing address of the ISA/CN | Authorized officer | |
| STATE INTELLECTUAL PROPERTY OFFICE OF THE P.R.CHINA 6, Xitucheng Rd., Jimen Bridge, Haidian District, Beijing 100088, China | GAO,Xiaoying | |
| Facsimile No. (86-10)62019451 | Telephone No. (86-10)62085364 | |

INTERNATIONAL SEARCH REPORT
Information on patent family members

International application No.

PCT/CN2016/070493

| Patent document cited in search report | | | Publication date (day/month/year) | Patent family member(s) | | | Publication date (day/month/year) |
|--|------------|----|-----------------------------------|-------------------------|---------|----|-----------------------------------|
| CN | 104907451 | A | 16 September 2015 | None | | | |
| CN | 101683913 | A | 31 March 2010 | None | | | |
| CN | 103817259 | A | 28 May 2014 | None | | | |
| JP | 2000015371 | A | 18 January 2000 | JP | 4217992 | B2 | 04 February 2009 |
| CN | 203698826 | U | 09 July 2014 | None | | | |
| WO | 9932242 | A1 | 01 July 1999 | GB | 9726606 | D0 | 18 February 1998 |
| | | | | AU | 1442699 | A | 12 July 1999 |