

No. 671,069.

Patented Apr. 2, 1901.

F. KAEFERLE.
QUICKSILVER RECEIVER.

(Application filed Jan. 2, 1901.)

(No Model.)

Fig. 1.

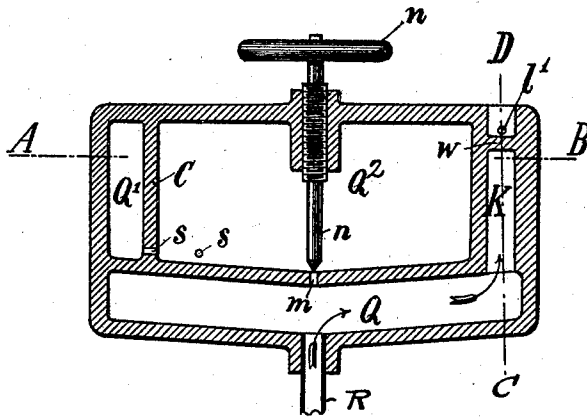

Fig. 2.

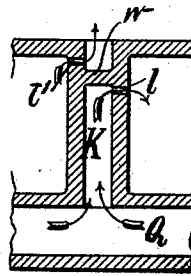
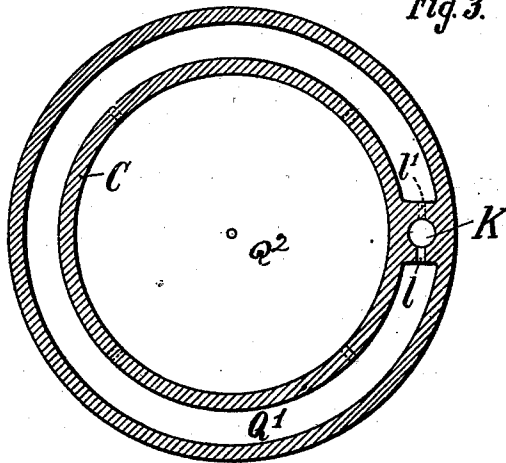

Fig. 3.



Witnesses:

A. J. Shedd
Attorney

Inventor:

Fritz Kaeferte
by his Attorney *A. J. Shedd*

UNITED STATES PATENT OFFICE.

FRITZ KAEFERLE, OF HANOVER, GERMANY.

QUICKSILVER-RECEIVER.

SPECIFICATION forming part of Letters Patent No. 671,069, dated April 2, 1901

Application filed January 2, 1901. Serial No. 41,916. (No model.)

To all whom it may concern:

Be it known that I, FRITZ KAEFERLE, engineer, a subject of the German Emperor; residing and having my post-office address at 3 Luerstrasse, Hanover, Germany, have invented certain new and useful Improvements in Quicksilver-Receivers, of which the following is a specification.

This invention relates to improvements in quicksilver-receivers.

Many apparatus, particularly pressure-regulators, pressure-reducers, and the like, require for their operation a certain quantity of quicksilver. The said quicksilver is generally contained in a chamber of the apparatus which on the one hand is under a certain pressure regulated by the latter itself and on the other hand under the pressure of the atmospheric air in such a manner that the quicksilver on the pressure increasing is forced out of its chamber into another chamber above, which must be in communication with the atmospheric air by means of an opening in order to allow the quicksilver to freely enter. If the pressure in the apparatus exceeds a certain limit, the quicksilver is partly or wholly forced out of the chamber through the said opening, and consequently lost. In addition to loss of quicksilver interruptions in the working are also caused through this occurrence, since there is generally no quicksilver at hand to immediately replace that lost.

The object of the present invention is an apparatus adapted to keep back the quicksilver forced out in the manner described, so that it can again be used immediately.

A form of construction of the present invention is shown in the annexed drawings, in which—

Figure 1 represents a section through the center of the apparatus. Fig. 2 is a section through the channel K on the line C to D of Fig. 1. Fig. 3 is a section on line A to B of Fig. 1.

The receiver is made, preferably, of cast-iron, and is connected, by means of a pipe R, with the apparatus the quicksilver of which is to be kept back. For instance, if the apparatus is a pressure-regulator a part of the quicksilver contained therein is forced into the chamber above on the apparatus being

put into operation. The apparatus consequently works under a pressure which corresponds to the quicksilver-column between the surface of the quicksilver in the lower and upper chambers of the apparatus. If from any accidental cause the pressure suddenly exceeds the desired limit, the quicksilver would be forced out of the opening leading from the upper chamber into the air, and thus be lost. This is prevented by means of the improved quicksilver-receiver connected with the upper chamber, which is marked Q in the drawings. The quicksilver forced out of the pressure-regulator passes through the pipe R into the chamber Q, which is not in direct communication with the atmospheric air. On the other hand there is a vertical conduit K, leading to the partition W, below which an aperture l leads laterally into the annular chamber Q'. At the other end of the said chamber Q' an aperture l' above the partition W passes into the atmospheric air. In the event of quicksilver passing into the chamber Q' through aperture l it cannot reach the orifice l' , and thus the air, which would be the case if apertures l and l' were arranged so as to form a straight line.

Owing to the annular shape of the chamber Q' the direction of the quicksilver entering the said chamber through aperture l is so continually changed that owing to the friction against the walls, and more especially against the outer wall of the chamber Q', it completely loses its speed and on account of its great specific weight falls to the bottom of the chamber, while the steam passing from behind the quicksilver above the same passes into the air through the aperture l' without carrying any quicksilver with it. The quicksilver passes from the bottom of chamber Q' through holes $s s$ in the wall C thereof into the accumulation-chamber Q², which is provided at its lowest part with a hole m , which can be closed by means of a screw-spindle n . If the said screw-spindle n is unscrewed, the quicksilver passes through the hole m again into the chamber Q and through the pipe R back to the pressure-regulator. It is obvious that the hole m must be kept closed during operation.

Instead of the annular form of the conduit Q' it may also have a triangular, quadrangu-

lar, or polygonal shape. The object of the invention, which is to prevent the quicksilver from passing from the aperture l to the aperture l' , is obtained by giving the distance
 5 from one to the other of said apertures as many different directions as possible, which is easily effected by means of the annular conduit shown in the present form of construction.

10 I declare that what I claim is—

1. An apparatus for the purpose described comprising in combination a chamber in indirect communication with the atmosphere and provided with an entrance for mercury
 15 and fluid, a second chamber in connection therewith, an accumulation-chamber having holes in the wall thereof for admitting mercury from the said second chamber and provided with an orifice for return of mercury to
 20 the first-mentioned chamber, and means for closing said orifice, substantially as set forth.

2. An apparatus for the purpose described, comprising in combination a chamber provided with an entrance for mercury and fluid,
 25 a conduit in connection therewith, a partition in said conduit, means of communication between the conduit and an annular chamber, means of communication between said annular chamber and the atmosphere,
 30 an accumulation-chamber having holes in the wall thereof for admitting mercury from the annular chamber and provided with an orifice at its lowest part for return of mercury to the first-mentioned chamber, and means
 35 for closing said orifice substantially as set forth.

3. An apparatus for the purpose described comprising in combination a chamber pro-

vided with an entrance for mercury and fluid, a vertical conduit in connection therewith, a
 40 partition in said conduit, means of communication between the conduit and an annular chamber above the first-mentioned chamber, means of communication between the annular chamber and the atmosphere, an accumu-
 45 lation-chamber having holes in the wall thereof for admitting mercury from said annular chamber and provided with an orifice at its lowest part for return of mercury to the said first-mentioned chamber and means for closing
 50 said orifice during operation substantially as set forth.

4. An apparatus for the purpose described, comprising in combination a chamber Q provided with an entrance R for mercury and
 55 fluid, a vertical conduit in communication therewith, a partition W at the upper end of said conduit, means of communication l , below said partition between the conduit and an annular chamber Q' placed above said chamber
 60 Q means of communication l' above said partition between said annular chamber Q' and the atmosphere, an accumulation-chamber Q² concentric with said annular chamber Q' having holes s in the wall C thereof for ad-
 65 mitting mercury from said annular chamber and provided with an orifice m at its lowest part for return of mercury to chamber Q and a screw-spindle n for closing said orifice substantially as set forth.

In witness whereof I have signed this specification in the presence of two witnesses.

FRITZ KAEFERLE.

Witnesses:

AUG. MEUKN,
 C. C. STEVENSON.