

(19) AUSTRALIAN PATENT OFFICE

(54) Title
Voltage control for wind generators

(51)⁶ International Patent Classification(s)
H02J 3/38 (2006.01) 2BMEP F03D
F03D 9/00 (2006.01) 9/00
H02J 3/38 20060101ALI2005100
20060101AFI2006072 8BMEP

(21) Application No: 2004208656 (22) Application Date: 2004 .09 .02

(30) Priority Data

(31) Number	(32) Date	(33) Country
10/655514	2003 .09 .03	US

(43) Publication Date : 2005 .03 .17

(43) Publication Journal Date : 2005 .03 .17

(71) Applicant(s)
General Electric Company

(72) Inventor(s)
Larsen, Einar V.

(74) Agent/Attorney
Davies Collison Cave, 255 Elizabeth Street, Sydney, NSW, 2000

(56) Related Art
US Eq 71194542
US 4400659
US Eq 7224081
US 4251735
US 4350947
US Eq 7166928

VOLTAGE CONTROL FOR WIND GENERATORS

ABSTRACT

A wind turbine generator control system includes relatively fast regulation of voltage (110) near the individual generators with relatively slower overall reactive power regulation at a substation or wind farm level (150). The setpoint of the relatively fast voltage regulator is adjusted by the relatively slow reactive power regulator. The fast voltage regulation can be at the generator terminals (115) or at a synthesized remote point (140).

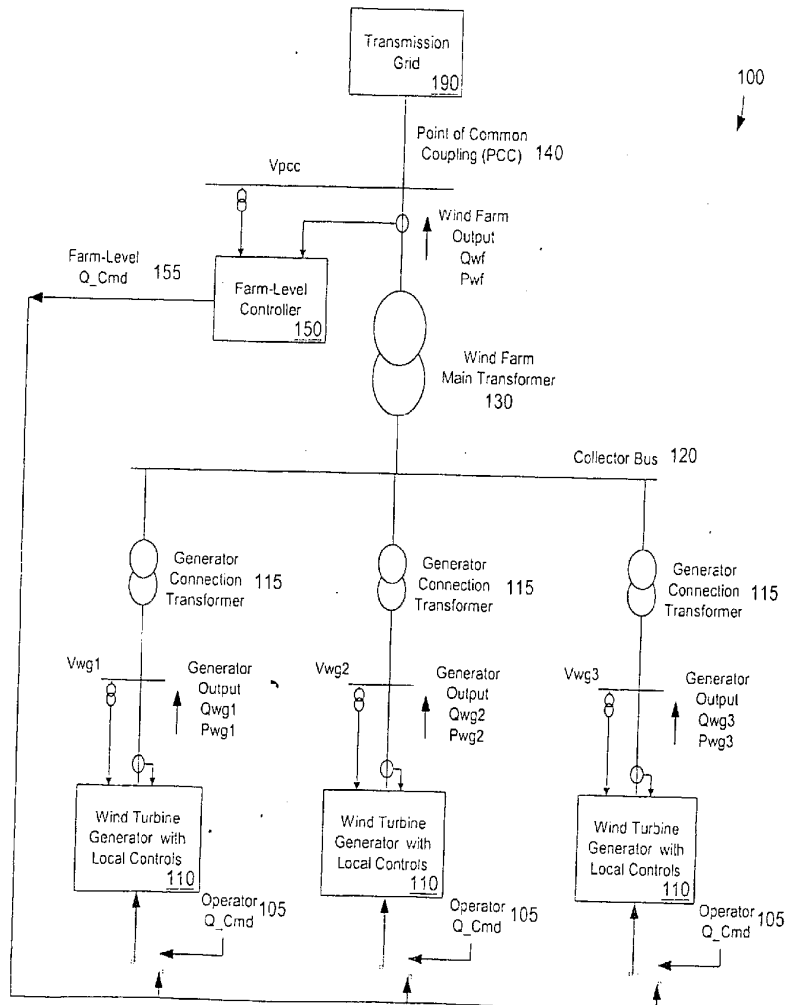

FIG. 1

VOLTAGE CONTROL FOR WIND GENERATORS

FIELD

The invention relates to wind turbine generators. More particularly, the invention relates to voltage control systems and techniques for use with wind turbine generators having continuous control of reactive power for at least part of the reactive power compensation function.

BACKGROUND

Wind power generation is typically provided by a wind "farm" of a large number (often 100 or more) wind turbine generators. Individual wind turbine generators can provide important benefits to power system operation. These benefits are related to mitigation of voltage flicker caused by wind gusts and mitigation of voltage deviations caused by external events.

In a wind farm setting each wind turbine generator can experience a unique wind force. Therefore, each wind turbine generator can include a local controller to control the response to wind gusts and other external events. Prior art wind farm control has been based on one of two architectures: local control with constant power factor and farm level control in fast voltage control, or local control in constant voltage control with no farm level control.

Both of these prior art control architectures suffer from disadvantages. Local control with constant power factor and farm level control in fast voltage control requires fast communications with aggressive action from the farm level to the local level. If the farm level control is inactive the local control can aggravate voltage flicker. With constant voltage control on each generator, steady-state operation varies significantly with small deviations in loading on the transmission grid. This causes the wind turbine generators to encounter limits in steady-state operation that prevent a response to disturbances - resulting in a loss of voltage regulation. Because reactive current is higher than necessary during this mode of operation, overall efficiency of the wind turbine generator decreases.

2004208656 10 Feb 2009

SUMMARY OF INVENTION

According to one aspect the present invention provides a wind turbine generator control system including:

5 a reactive power regulator to control reactive power production by the wind turbine generator by adjusting a voltage setpoint to a voltage regulator, the reactive power regulator having a first time constant; and

10 a voltage regulator coupled with the reactive power regulator to control real power production by the wind turbine generator by generating a signal to indicate a wind turbine rotor current, the voltage regulator having a second time constant, wherein the first time constant is numerically greater than the second time constant.

BRIEF DESCRIPTION OF THE DRAWINGS

15

The invention is illustrated by way of example, and not by way of limitation, in the figures of the accompanying drawings in which like reference numerals refer to similar elements.

20

Figure 1 is a block diagram of a wind farm having multiple wind turbine generators coupled with a transmission grid.

25

Figure 2 is a control diagram of one embodiment of a wind turbine generator control system.

30

Figure 3 is a flow diagram of one embodiment of operation of a wind turbine control system.

35

Figure 4 is an example set of waveforms corresponding to a prior art local control with constant power factor without wind farm level control.

2004208656 10 Feb 2009

- 2A -

Figure 5 is an example set of waveforms corresponding to a prior art local control with constant power factor and wind farm level control in fast voltage control.

5 Figure 6 is an example set of waveforms corresponding to local control of a wind turbine generator having a controller as described in Figure 2, without wind farm level control.

10 Figure 7 is an example set of waveforms corresponding to local control in a wind turbine generator having a controller as described in Figure 2, with wind farm level control.

DETAILED DESCRIPTION

15 A wind turbine generator control system includes relatively fast regulation of voltage for individual generators with relatively slower overall reactive power regulation at a substation or wind farm level. The relatively slow reactive power regulator adjusts the set point of the relatively fast voltage regulator. The fast voltage regulation can be at the generator terminals or at a synthesized remote point (e.g., between the generator

terminals and the collector bus). Prior art reactive power controllers are designed with time constants of lower numerical value than those used in voltage regulator design. That is, in the prior art, the reactive power control loop is inside of the voltage control loop, which results in a less stable system than described herein.

Figure 1 is a block diagram of a wind farm having multiple wind turbine generators coupled with a transmission grid. Figure 1 illustrates only three wind generators; however, any number of wind generators can be included in a wind farm.

Each wind turbine generator 110 includes a local controller that is responsive to the conditions of the wind turbine generator being controlled. In one embodiment, the controller for each wind turbine generator senses only the terminal voltage and current (via potential and current transformers). The voltage and current sensed are used by the local controller to provide an appropriate response to cause the wind turbine generator to provide the desired reactive power and voltage. A control system diagram corresponding to one embodiment of a wind turbine generator controller is described in greater detail below with respect to Figure 2.

Each wind turbine generator 110 is coupled to collector bus 120 through generator connection transformers 115 to provide real and reactive power (labeled P_{wg} and Q_{wg} , respectively) to collector bus 120. Generator connection transformers and collector buses are known in the art.

Wind farm 100 provides real and reactive power output (labeled P_{wf} and Q_{wf} , respectively) via wind farm main transformer 130. Farm level controller 150 senses the wind farm output as well as the voltage at point of common coupling 140 to provide a farm level reactive power command (Farm Level Q Cmd) 155. In one embodiment, farm level controller 150 provides a single reactive power command to all wind turbine generators of wind farm 100. In alternate embodiments, farm level controller 150 provides multiple commands for subsets of wind turbine generators of wind farm 100. The commands to subsets of wind turbine generators can be based on, for example, additional information related to the operating conditions of one or more wind turbine generators.

The control system of Figure 2 provides an improved control structure involving both local and farm level control to overcome the disadvantages of the prior art control architectures described above. The control system of Figure 2 eliminates the requirement for fast and aggressive control from the wind farm level. Improved response is provided if the farm level control is out of service. In addition, efficient steady-state operation is achieved, while system dynamic response remains well within the limits set.

Figure 2 is a control system diagram corresponding to one embodiment of a wind turbine generator control system. In one embodiment, the control system of a wind turbine generator generally includes two loops: a voltage regulator loop and a Q regulator loop. The voltage regulator loop operates relatively fast (e.g., 20 rad/sec) as compared to the Q regulator loop (e.g., greater than 1 second closed loop time constant). The Q regulator adjusts the set point of the voltage regulator.

Conceptually, the control system of Figure 2 provides for wind turbine generator terminal voltage control by regulating the voltage according to a reference set by a higher-than-generator-level (e.g., substation or wind farm) controller. Reactive power is regulated over a longer term (e.g., several seconds) while wind turbine generator terminal voltage is regulated over a shorter term (e.g., less than several seconds) to mitigate the effects of fast grid transients.

Operator or farm level Q command 200 is a signal that indicates desired reactive power at the generator terminals. In farm level operation, the wind turbine generator Q command 200 is set equal to the output of the farm level control (line 155 in Fig 1). In local control, the operator command is set manually, either at the wind generator location or at a remote location. Operator or farm level Q command 200 can be generated or transmitted by, for example, a computer system used to control the wind turbine generator. Operator or farm level Q command 200 can also come from a utility grid operator or substation.

In one embodiment, operator or farm level Q command 200 is transmitted to command limiter 220, which operates to maintain reactive power commands within a

predetermined range. Q_{max} 222 and Q_{min} 224 indicate the upper and lower bounds on the reactive power command range.

The specific values used for Q_{max} and Q_{min} are based on, for example, generator reactive capability. In one embodiment the value for Q_{max} is 800 kVAR and the value for Q_{min} is -1200 kVAR for a 1.5 MW wind turbine generator; however, the specific values are dependent upon the capability of the generators being used.

The signal output by command limiter 220 is Q command 230, which is a command indicating the target reactive power to be produced. Q command 230 is in the range between Q_{min} 224 and Q_{max} 222. Q command 230 is compared to a signal indicating measured reactive power 210. The resulting error signal, Q error 235, indicates the difference between the measured reactive power and the commanded reactive power.

Q error 235 is an input signal to Q regulator 240, which generates V command 250 that indicates to a generator the reactive power to be provided by the generator. In one embodiment Q regulator 240 is a proportional integral (PI) controller that has a closed-loop time constant in the range of 1 to 10 seconds (e.g., 3 seconds, 5 seconds, 5.5 seconds). Other types of controllers can also be used, for example, proportional derivative (PD) controllers, proportional integral derivative (PID) controllers, state space controllers, etc. Other time constants can be used for Q regulator 240 provided that the time constant for Q regulator 240 is numerically greater than the time constant for voltage regulator 270.

V command 250 is limited to a predetermined range between V_{max} 242 and V_{min} 244. In one embodiment, V_{max} 242 and V_{min} 244 are defined in terms of percentage of rated generator output. For example, V_{max} 242 can be 105% of rated generator voltage and V_{min} 244 can be 95% of rated generator voltage. Alternate limits can also be used.

V command 250 is compared to a signal indicating measured terminal voltage 255 for the generator. The difference between V command 250 and measured terminal voltage 255 is voltage error signal 260. Voltage error signal 260 is the input signal to voltage regulator 270.

Voltage regulator 270 generates rotor current command 280, which is used to control generator rotor current. In one embodiment Q regulator 240 is a PI controller that has a closed-loop time constant of approximately 50 milliseconds. Other types of controllers can also be used, for example, PD controllers, PID controllers, etc. Other time constants can be used (e.g., 1 second, 20 milliseconds, 75 milliseconds, 45 milliseconds) for voltage regulator 270 provided that the time constant for voltage regulator 270 is less than the time constant for Q regulator 240.

In general, there are two components of a rotor current command. They are the real power component denoted as I_{rq_Cmd} and the reactive power component denoted as I_{rd_Cmd} . The rotor current command (240) generated as described with respect to Figure 2 is the reactive component or I_{rd_Cmd} command. The real component or I_{rq_Cmd} can be generated in any manner known in the art. Rotor current command 280 is limited to I_{rdmax} 272 and I_{rdmin} 274. The values for I_{rdmax} 272 and I_{rdmin} 274 can be based on generator current ratings. For example, I_{rdmax} 272 can be rated crest current for the generator rotor and I_{rdmin} 274 can be a percentage of rated crest current for the generator rotor. Alternate limits can also be used.

In one embodiment, all of the limits discussed with respect to Figure 2 are non-windup limits; however, in alternate embodiments, a subset of the limits can be non-windup limits. The limits have been discussed in terms of fixed parameters; however, dynamically variable parameters provided by, for example, a lookup table or a processor or state machine executing a control algorithm can provide the limits. Such a dynamically variable limit may be based upon a current rating of the generator and a contemporaneous real power output

Figure 3 is a flow diagram of one embodiment of operation of a generator control system. A reactive power command is received, 300. As mentioned above, the reactive power command can be an Operator command, farm level command, or a local command.

A voltage setpoint is determined based on the reactive power command, 305. The voltage setpoint is limited to a range defined by upper and lower limits that are based

on generator terminal voltage. In one embodiment, the limits are defined in terms of percentage of rated generator output. For example, the upper limit can be 105%, 110%, 102%, 115% of rated generator voltage and the lower limit can be 95%, 98%, 92%, 90%, 97% of rated generator voltage. Alternate limits can also be used.

A rotor current command for the generator is determined based on the voltage setpoint, 315. The rotor current command is limited, 320, to a range based on, for example, the current rating of the generator. For example, crest current ratings can be used for the limits, or percentages of crest current ratings can be used for the limits. The rotor current command is transmitted to the rotor controller, 325. The rotor controller causes the commanded current to be provided to the generator rotor. The generator then provides a reactive power output based on the rotor current provided, 330.

Figures 4 and 5 illustrate typical characteristic wind turbine generator operating behavior for prior art control systems. These plots show response of the wind turbine generators and of the total farm with and without fast farm level voltage control. The individual wind turbine generators are operated in constant power factor control with a setpoint to yield overexcited operation (as might be required to support the transmission system external to the wind farm). In Figures 4 and 5, the following variables are portrayed, from top to bottom (refer to Fig 1 to see where these are on the wind farm): P_{wg} is the real power from an individual wind turbine generator, Q_{wg} is the reactive power from the generator, Q_Cmd_Farm is the output of farm level controller (line 155 in Fig 1), V_{wg} is the terminal voltage of the generator, V_{pcc} is the voltage at point of common coupling (140 on Fig 1). The goal is generally to maintain V_{pcc} at a constant value even when the power fluctuates due to variations in wind speed.

Figure 4 is prior art with local control only (i.e., Q_Cmd_Farm is constant). Note that the signal V_{pcc} varies considerably with power fluctuations P_{wg} , which is undesirable. Figure 5 is prior art with farm level control activated. While V_{pcc} is much more stable than in Figure 4, the control signal from the farm level varies

considerably. This is because the farm level control must overcome the inherent adverse effects of the prior art local control.

Figures 6 and 7 are comparable to Figures 4 and 5, but with the control described in Figure 2. The inherent response of the local control is generally relatively good, so that farm level control provides only trim control. Thus, the objective of allowing farm level control to be less aggressive and slower are achieved with the new control.

Reference in the specification to "one embodiment" or "an embodiment" means that a particular feature, structure, or characteristic described in connection with the embodiment is included in at least one embodiment of the invention. The appearances of the phrase "in one embodiment" in various places in the specification are not necessarily all referring to the same embodiment.

In the foregoing specification, the invention has been described with reference to specific embodiments thereof. It will, however, be evident that various modifications and changes can be made thereto without departing from the broader spirit and scope of the invention. The specification and drawings are, accordingly, to be regarded in an illustrative rather than a restrictive sense.

Throughout this specification and the claims which follow, unless the context requires otherwise the word "comprise", or variations such as "comprises" or "comprising", will be understood to imply the inclusion of a stated integer or step or group of integers or steps but not the exclusion of any other integer or step or group of integers or steps.

5

The reference to any prior art in this specification is not, and should not be taken as an acknowledgment or any form of suggestion that, that prior art forms part of the common general knowledge of Australia.

The reference numerals in the following claims do not in any way limit the scope of the respective claims.

2004208656 10 Feb 2009

- 9 -

The claims defining the invention are as follows:

1. A wind turbine generator control system including:
a reactive power regulator to control reactive power production by the wind turbine
5 generator by adjusting a voltage setpoint to a voltage regulator, the reactive power regulator
having a first time constant; and

a voltage regulator coupled with the reactive power regulator to control real power
10 production by the wind turbine generator by generating a signal to indicate a wind turbine rotor
current, the voltage regulator having a second time constant, wherein the first time constant is
numerically greater than the second time constant.
2. The wind turbine generator control system of claim 1 wherein the first time constant is
greater than one second.
15
3. The wind turbine generator control system of claim 1 wherein an input signal to the
reactive power regulator includes an error signal indicating a difference between a command
limited to a predetermined range and a signal indicating measured reactive power.
- 20 4. The wind turbine generator control system of claim 3 wherein the predetermined range is
defined by upper and lower limits based on generator reactive power capacity.
5. The wind turbine generator control system of claim 1 wherein an output signal from the
reactive power regulator is limited to a predetermined range.
25
6. The wind turbine generator control system of claim 5 wherein the predetermined range is
defined by upper and lower limits based on generator terminal voltage.
7. The wind turbine generator control system of claim 6 wherein the lower limit includes
30 approximately 95% of steady-state rated generator voltage and the upper limit includes
approximately 105% of steady-state rated generator voltage.

2004208656 10 Feb 2009

- 10 -

8. The wind turbine generator control system of claim 1 wherein an input signal to the voltage regulator includes an error signal indicating a difference between an output signal from the reactive power regulator limited to a predetermined range and a signal indicating measured terminal voltage.
- 5
9. The wind turbine generator system of claim 8 wherein the predetermined range is defined by an upper and a lower limit based on converter ratings and/or operating set points.
- 10
10. The wind turbine generator system of claim 8 wherein an output signal from the voltage regulator includes a current command to a generator exciter.
11. The wind turbine generator system of claim 8 wherein an output signal from the voltage regulator determines a current to be supplied to the generator.
- 15
12. A wind turbine generator control system, substantially as hereinbefore described with reference to the accompanying drawings.
13. A method of controlling a wind turbine generator, substantially as herein described.
- 20

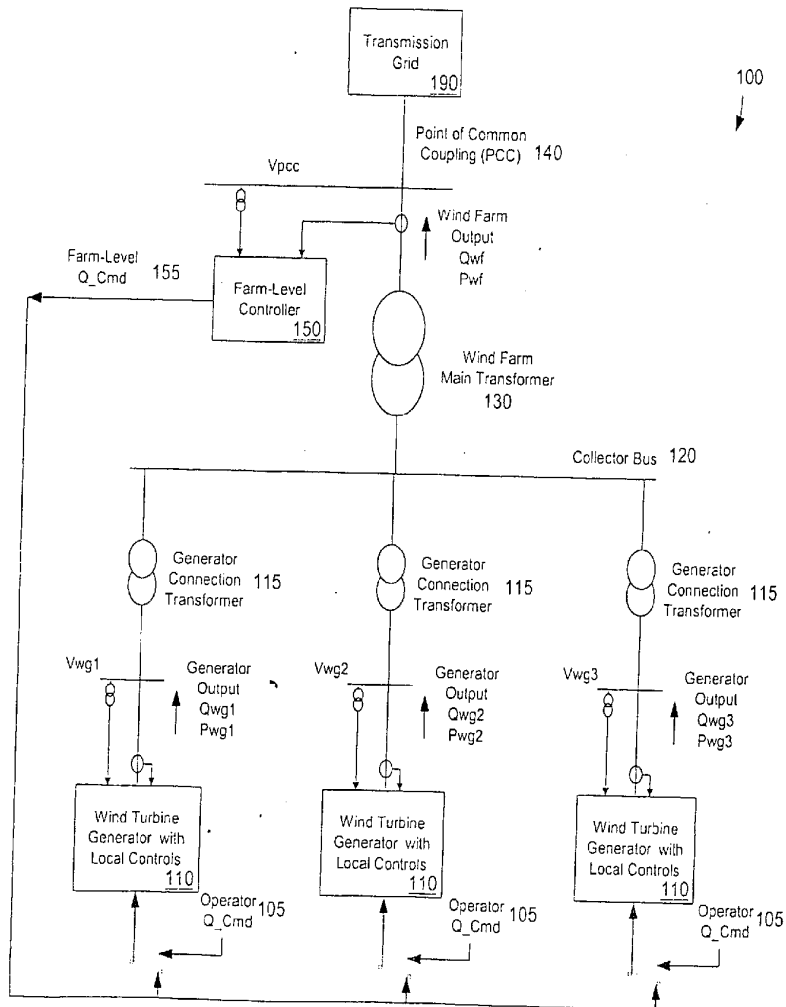

FIG. 1

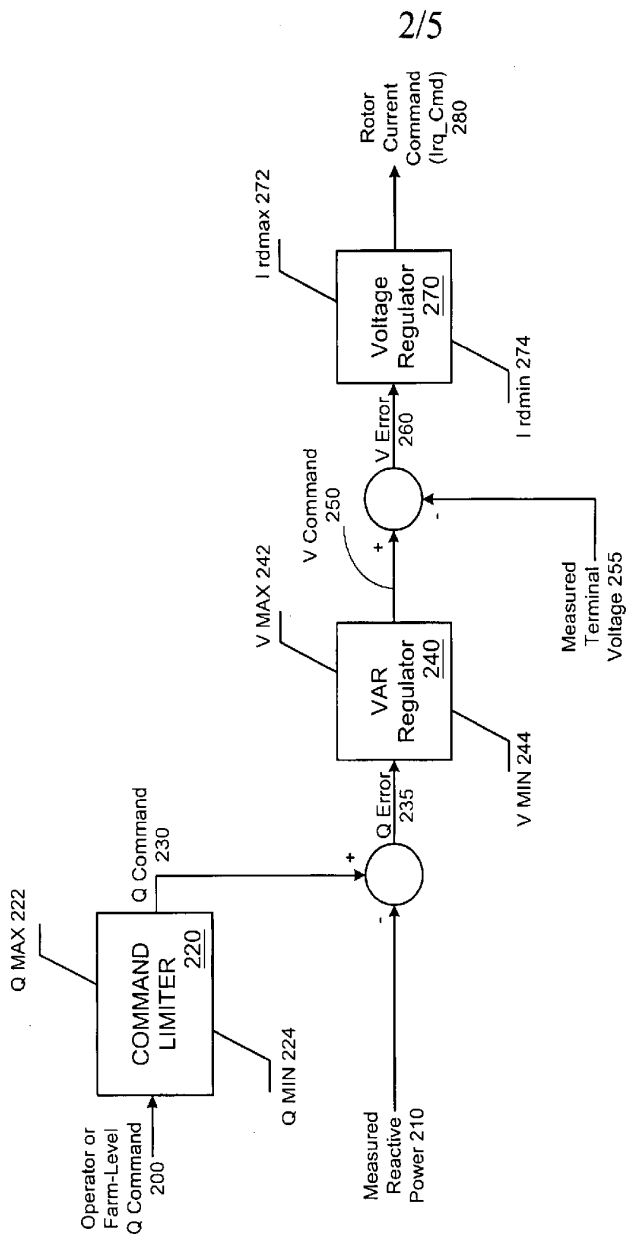

FIG. 2

3/5

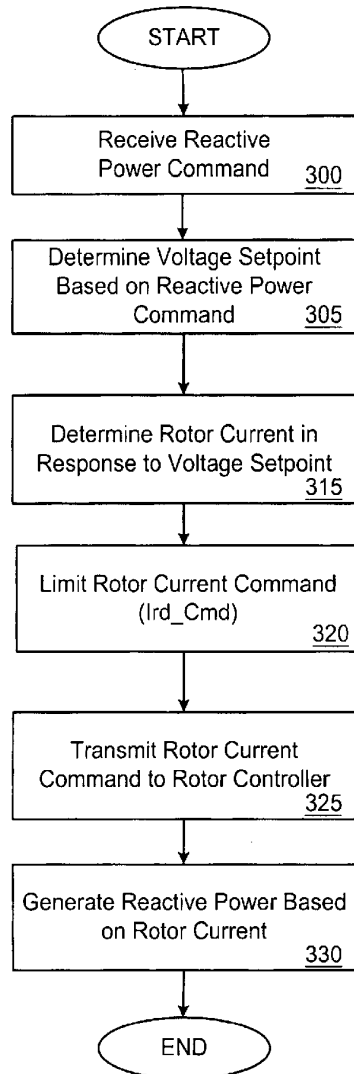

FIG. 3

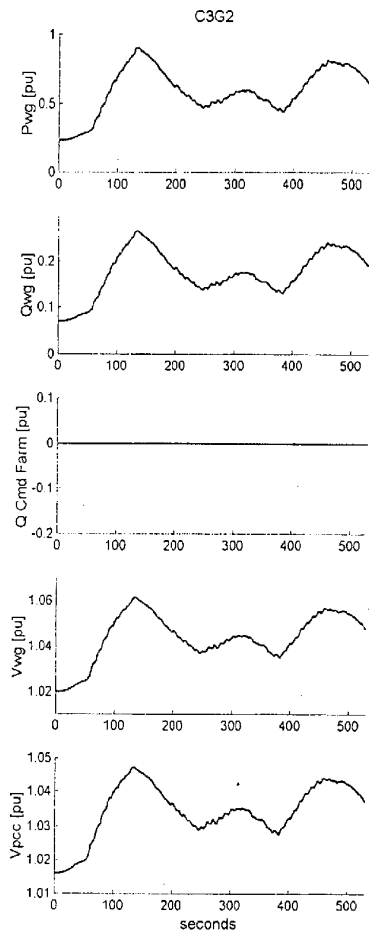

Fig. 4

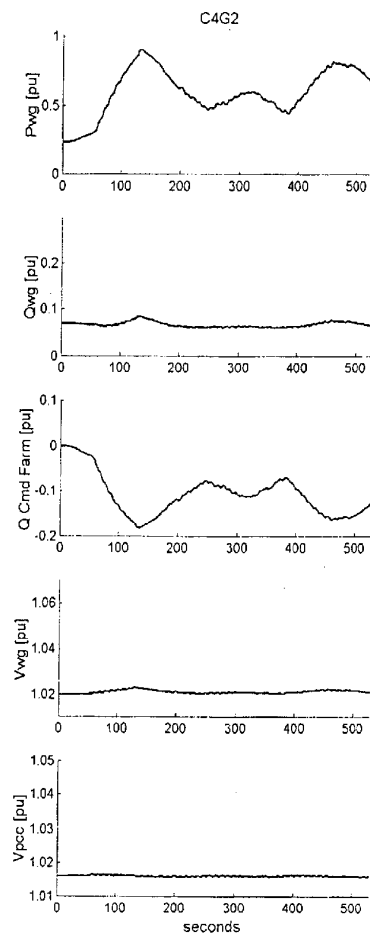

Fig. 5

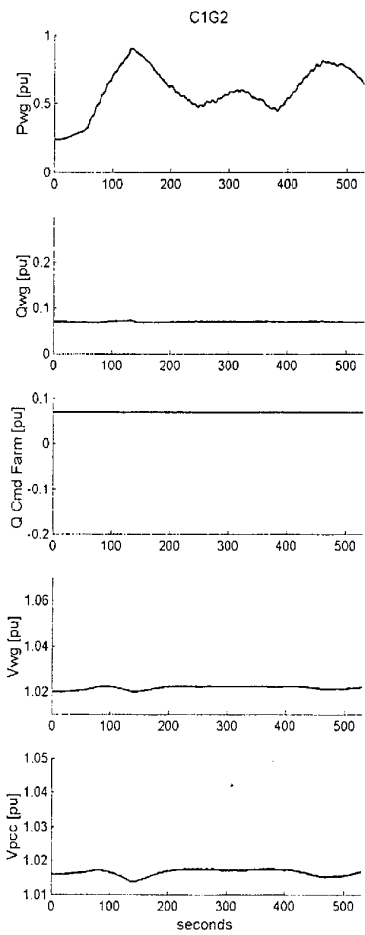

Fig. 6

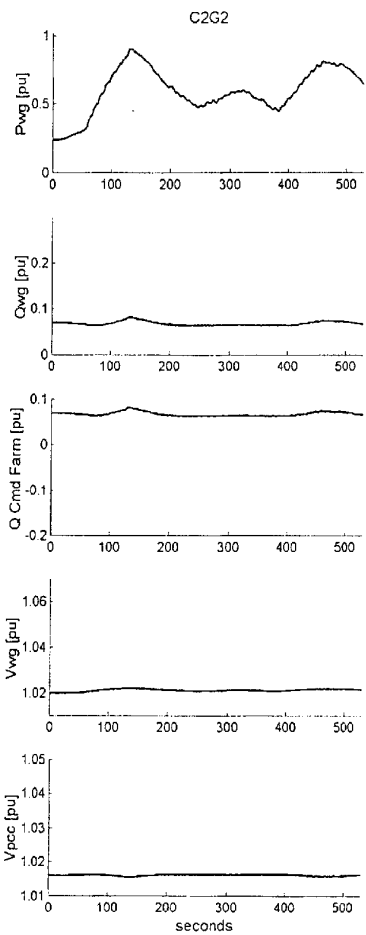

Fig. 7