

S. Darling,
Inkstand.

No 111,435.

Patented Jan. 31. 1871.

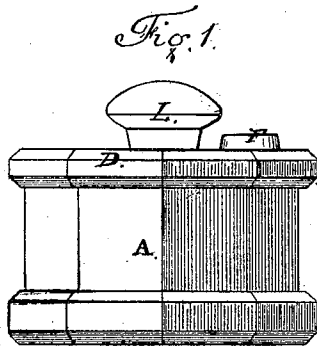
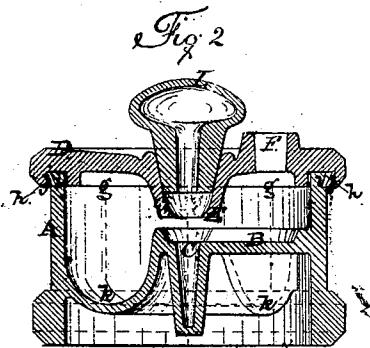

Fig 3

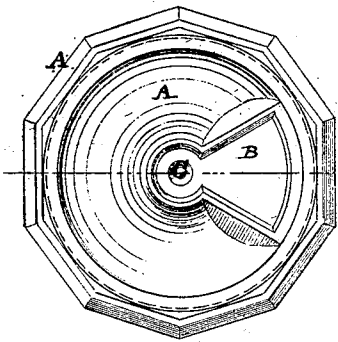

Fig 4

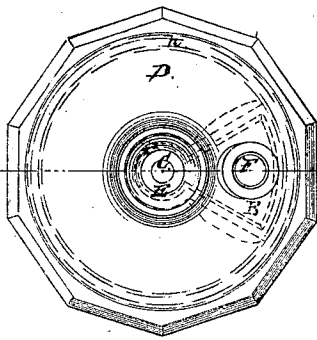
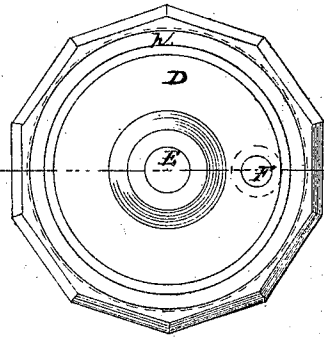

Fig 5.



Witnesses:

J. J. Beale,
Wilmer, Bradford.

Samuel Darling Inventor.

by Crosby, Halsted & Gould
his Attorneys.

United States Patent Office.

SAMUEL DARLING, OF PROVIDENCE, RHODE ISLAND.

Letters Patent No. 111,435, dated January 31, 1871.

IMPROVEMENT IN INKSTANDS.

The Schedule referred to in these Letters Patent and making part of the same.

To all whom it may concern :

Be it known that I, SAMUEL DARLING, of Providence, in the State of Rhode Island, have invented certain Improvements in Inkstands; and I do hereby declare that the following, taken in connection with the drawing which accompanies and forms part of this specification, is a description of my invention sufficient to enable those skilled in the art to practice it.

My improvements consist in a special construction of the inkstand itself; and also in an inkstand having a hollow elastic stopper, to avoid any compression of the air within the stand when the stopper is pressed in.

One form in which I have embodied my improvements I have illustrated in the accompanying drawing, in which—

Figure 1 represents an elevation of an inkstand; and

Figure 2, a central vertical section of the same, showing my novel features.

Figure 3 is a plan view of the lower part before the top has been put on; and

Figures 4 and 5 are plan views, respectively, of the stand with the elastic stopper removed, and of the top part or piece as seen on its under side.

I make my inkstand of two or more parts, but preferably of two, as shown, when made of glass or other molten, molded, or cast material, as such material admits of forming the lower part or reservoir in the same piece with the elevated ink-chamber contained within it, as also with the pen-gauge.

A is the lower part or main reservoir.

B, the elevated ink or dipping-cup, having walls around it of proper height, as seen in the drawing, the chamber formed by these walls constituting, in connection with the deep cavity C, the pen-gauge or dipping-gauge, the object of such gauge being to determine and limit positively, by the height of the walls, the amount of ink to be taken upon the pen, which ink can never have a depth greater than the prescribed height of the walls permits.

D is the top part, constructed to be united to the lower part by an ink-tight joint.

E is the dipping-cup or tube, through which the pen is passed when it needs a supply of ink from the ink-chamber, and which also forms a downwardly-projecting annular wall, to prevent the ink from falling out when the inkstand is tipped or inverted, either to supply the ink-trough from the main reservoir A, or by accident, or when traveling.

The hole F is for the escape of air when the inkstand is being supplied with ink, which is done through the dipping-hole or cup E, this hole F being kept

tightly corked or closed when the inkstand is in use. It is also used for pouring out from the stand any ink or water whenever necessary.

The ink-chamber B, it will be seen, is quite shallow, as it is not necessary to contain much ink at a time; and the pen-gauge C is a deep, gradually-tapering cavity, having its largest diameter (which is at the top) less than the breadth of any ordinary pen, thus preventing positively any descent of the pen beyond a predetermined point, the tip of the pen being also, by reason of the depth of the chamber of this gauge, prevented from ever touching bottom; and from being thereby injured, or from picking up any sediment which might collect there.

The deeper the walls of the ink-chamber B, the greater will be the quantity of ink the pen can take up at a dip.

The supply of ink should not be more than the stand will hold when inverted, preferably a little less than this; but any lesser quantity will be sufficient for present use so long as there be enough to supply the chamber B; and whether the bottom of the reservoir A be flat on its inside, or rounded up, as shown in the drawing, will be unimportant, so far as relates to the operation of the inkstand or the supply of the chamber B.

L is the tubular stopper, formed of India rubber or equivalent elastic material, and having a chambered top, as seen, the chamber communicating with the bore of the tube.

With ordinary solid stoppers, when they are pressed down tightly, the air is compressed inside of the inkstand, and for the purposes for which it is more especially designed, namely, for children's and family use, and for traveling, this is objectionable, because when somewhat heated (and even when not) the compressed air has a tendency to force out the ink around the stopper when the stand gets inverted and much damage and inconvenience result.

In using my stopper, its head or bulb is compressed between the thumb and finger as it is about to be applied, and a portion of the air expelled from it, so that it will admit of being pressed down into the mouth or tube of the inkstand without leaving any compressed air within, as a part of the air is free to rise in the stopper to supply the vacuum previously created therein.

A thin pipe may, if thought desirable, be inserted in that portion of the stopper which enters the inkstand, to prevent its collapsing so as to close the hole.

I do not claim, broadly, an inkstand constructed so as not to spill ink when tipped or inverted; nor an

inkstand having an ink-cup to hold a supply of ink at an elevation higher than that in the main reservoir.

Nor do I claim, broadly, a pen-gauge, for limiting the descent of the pen and preventing damage to its nib; but

What I claim is—

1. An inkstand having an elevated dipping-cup within the reservoir, and an ink-receiving cavity in

the upper part, constructed and operating substantially as described.

2. An inkstand having a hollow, elastic stopper, substantially as and for the purpose set forth.

SAMUEL DARLING.

Witnesses:

H. J. SPOONER,
JOHN H. STINESS.