

(No Model.)

C. B. STILWELL.
PAPER BAG MACHINE.

No. 410,126.

Patented Aug. 27 1889.

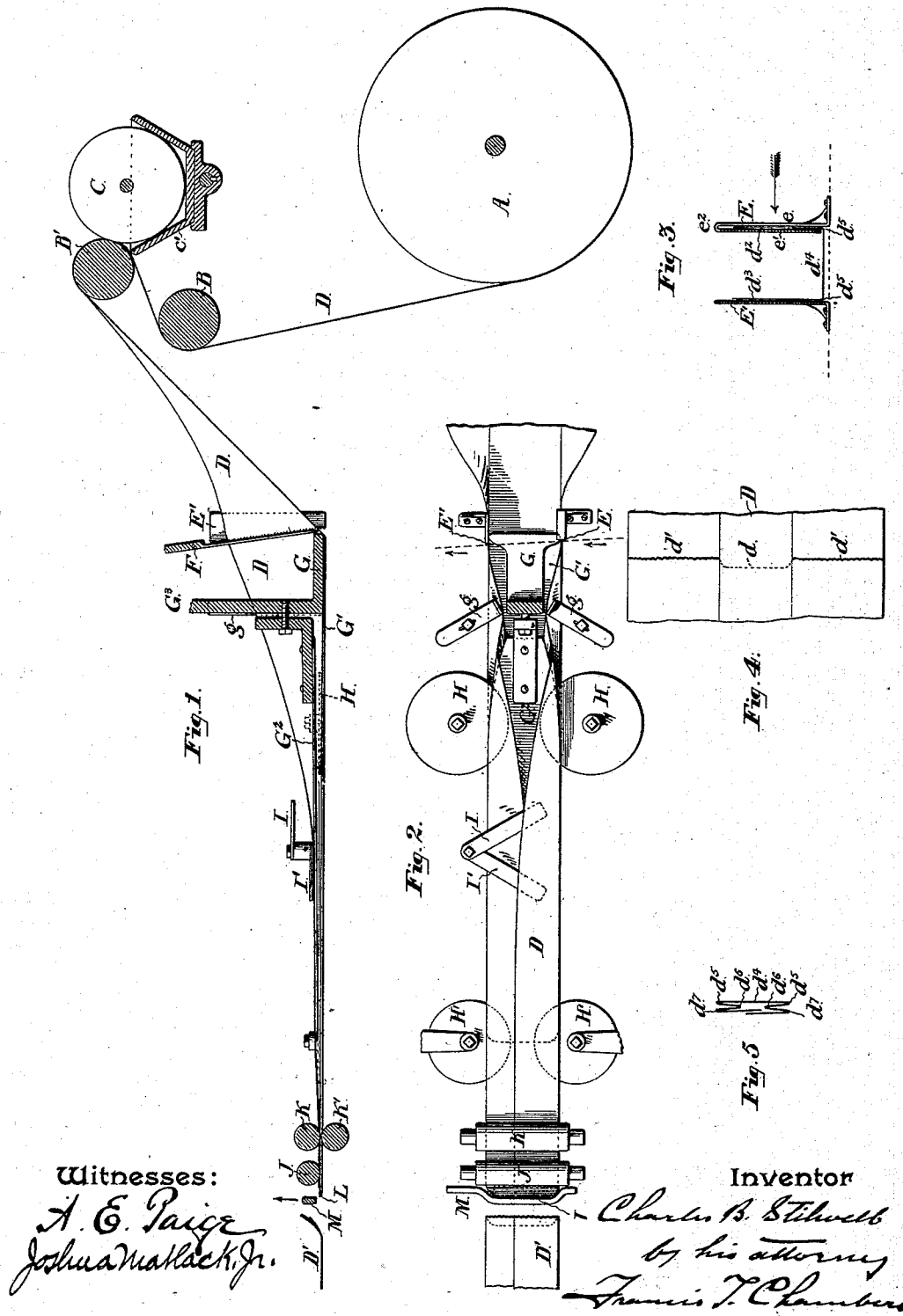

UNITED STATES PATENT OFFICE.

CHARLES B. STILWELL, OF PHILADELPHIA, PENNSYLVANIA, ASSIGNOR TO
THE UNION PAPER BAG MACHINE COMPANY, OF SAME PLACE.

PAPER-BAG MACHINE.

SPECIFICATION forming part of Letters Patent No. 410,126, dated August 27, 1889.

Application filed January 28, 1889. Serial No. 297,786. (No model.)

To all whom it may concern:

Be it known that I, CHARLES B. STILWELL, of the city and county of Philadelphia, State of Pennsylvania, have invented a new and useful Improvement in Paper-Bag Machines, of which the following is a true and exact description, reference being had to the accompanying drawings, which form a part of this specification.

10 My invention relates to the mechanism by which a web of paper is formed into a bellows-folded tube and severed into bag-blanks, and has for its object to provide improved means for severing the blanks from the web.

15 My improvement will be best understood as described in connection with the drawings, in which it is illustrated, and in which—

Figure 1 is a sectional elevation through the tube-forming mechanism on its center line; Fig. 2, a plan view thereof; Fig. 3, a front view of the knives on which the first cutting of the web is done; Fig. 4, a view showing the cuts by which the web is severed, and Fig. 5 a cross-section of the folded tube.

25 A is the roll of paper; B B', guide-rolls; C, the paste-roll; C', the paste-trough, and D the web of paper.

G³ is a standard, on which is supported former-plates G' G³, G being the upwardly-curved back end of the lower former-plate.

H H are wheels, whose function it is to push the paper between the former-plates G' G³ to form the bellows folds, fingers being well-known equivalents for them.

35 I and I' are fingers, whose function it is to lay the edges of the web down over the former G³; H' H', wheels for further guiding the paper as it moves along the former-plates; K K', presser-rolls for pressing down the pasted seam and feeding the web along.

40 The machinery as thus far described is in substance of a familiar type, and is here given simply as an instance of tube-forming mechanism, and not as an essential part of my invention.

45 At the end of the former to which the web D passes I erect knives E E', the knife E having its cutting-blade e' supported from a standard e, to which it is connected at the top, as is shown at e². The knife E' is preferably set a little in front of E, as is shown in Fig. 2.

F is a striker, which operates in connection with the knives E E', moving in the direction indicated by the arrows and dotted line in Fig. 2. The paper web D is drawn under the 55 end G of the lower former-plate, which, being of the same breadth, defines the portion d⁴, which forms the under side of the tube. The edge d² is inserted between the cutting-blade e' and the standard e, and the edge d³ 60 rests against the inside of cutter E'. The striker F, operating at proper intervals, severs these edges on the lines d' d', Fig. 4. The web, after leaving the cutters E E', is pressed down on the edge of the lower former-plate 65 by the fingers g g, the cut edges of the paper being of course guided beneath the fingers g by some convenient form of guide-plate, which, as such guide-plates are familiar devices, I have omitted in the drawings, so as 70 not to obscure the more important parts of the mechanism. After passing beneath fingers g the web, passing by the wheels H H, is tucked between the former-plates, thus defining the creases d⁶ of the bellows fold, the 75 fingers I I' folding the edges down over the upper former and defining the creases d⁷ d⁷, the lapping edges being pressed together by rolls K K', and the tube thus completed, it being made up of partially-severed bag-blanks 80 united only on the under side d⁴. This tube is then led over a knife-blade L, preferably formed on the end of former-plate G', in which case a bearing-roll J should be used to support the end of the former, and a striker M 85 completes the severing of the bag-blanks, the knife being given the curved form shown, in order to form a projecting lip on the under side of the blank. (See d, Fig. 4.)

D' indicates the rear end of a blank just 90 severed from the web.

The blanks may be formed into bags in any convenient way.

It will be understood that my invention is not limited to the use of any particular tube- 95 forming mechanism, but to the combination with such mechanism of the cutting devices shown. Any convenient guiding and deflecting fingers or other devices may be used to direct the folding of the paper as the web 100 moves through the forming mechanism, the use of such appliances being well understood,

and I have in the drawings shown only the well-known and most essential parts of such mechanism.

5 Having now described my invention, what I claim as new, and desire to secure by Letters Patent, is—

10 In a paper-bag machine, the combination, with mechanism for folding a web of paper into a bellows-sided tube, of mechanism consisting of cutting-knives E E' and a striker F, arranged at the end of the folding mech-

anism to which the web passes, so as to cut the web on each side on the lines *d' d'*, and a knife and striker at the other end of the folding mechanism for severing the under 15 side of the tube and forming a lip *d*, all substantially as and for the purpose specified.

CHAS. B. STILWELL.

Witnesses:

WILLIAM H. DOERING,
LISLE STOKES.