

Dec. 9, 1941.

D. GOODMAN

2,265,479

CHAPEL TENT

Filed Dec. 30, 1940

2 Sheets-Sheet 1

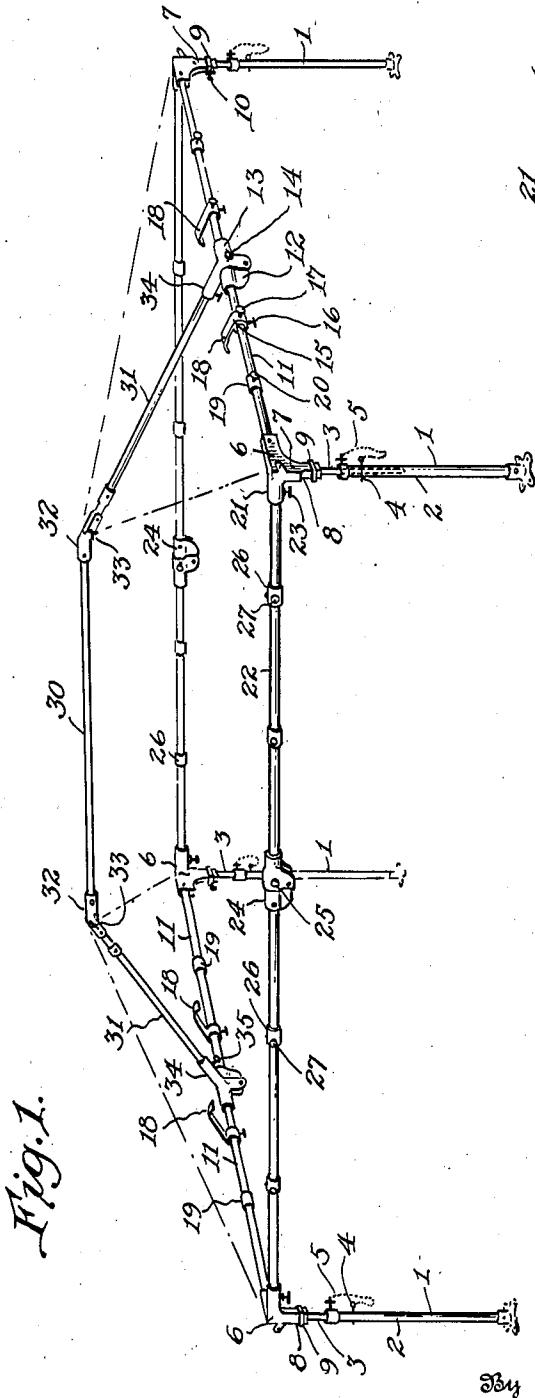

Fig. 1.

324

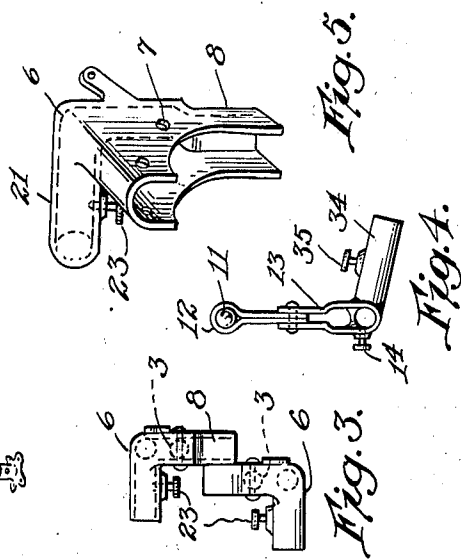

Fig. 3.

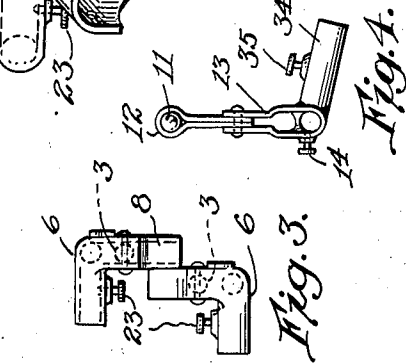

Fig. 4.

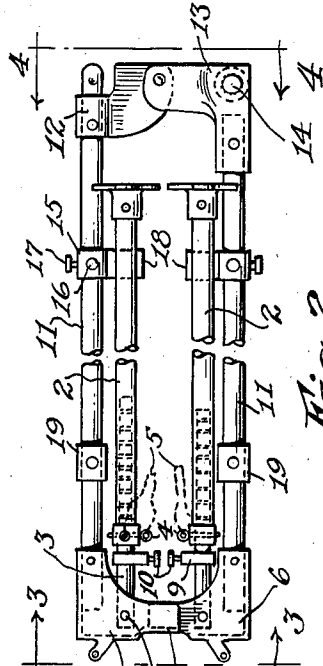

Fig. 5.

Fig. 2.

Inventor
Dwight Goodman

Excelsior & Excelsior,
Attorneys

Dec. 9, 1941.

D. GOODMAN

2,265,479

CHAPEL TENT

Filed Dec. 30, 1940

2 Sheets-Sheet 2

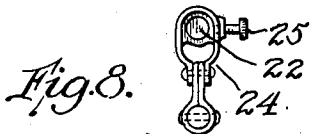
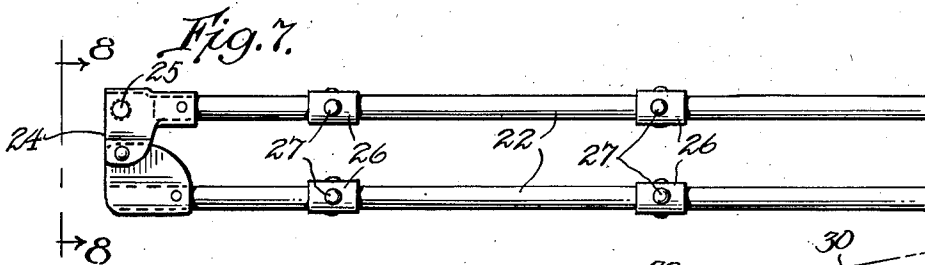
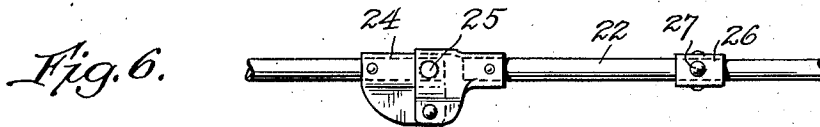

Fig. 9.

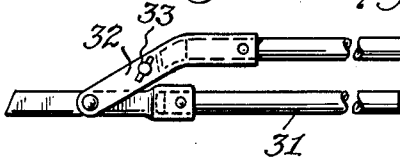
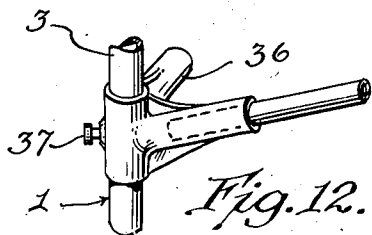
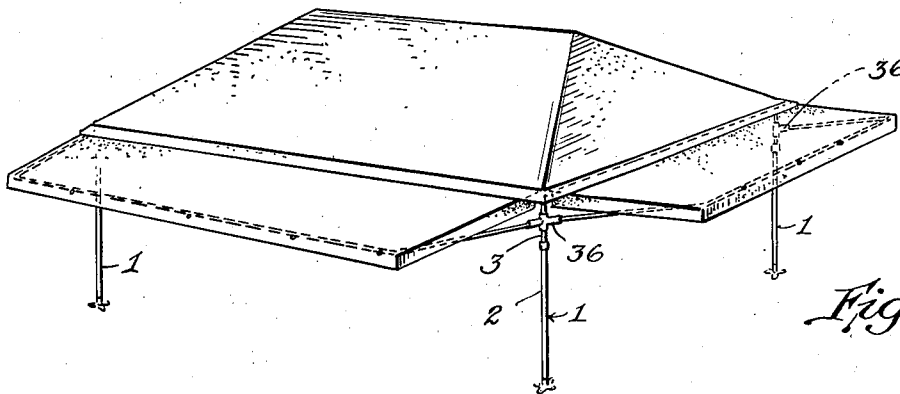
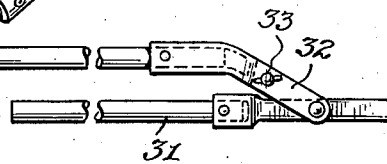

Fig. 10.



Inventor
Dwight Goodman

Eccleston & Eccleston,
Attorneys

UNITED STATES PATENT OFFICE

2,265,479

CHAPEL TENT

Dwight Goodman, Columbus, Ohio

Application December 30, 1940, Serial No. 372,403

12 Claims. (Cl. 135—4)

This invention relates primarily to chapel tents, but is also obviously useful in temporary shelters for concessions, and as a display tent or the like.

One of the objects of the invention resides in the provision of a tent frame which may be readily folded in a compact manner for transportation, and yet which is sufficiently strong to remain in set-up condition despite all sorts of inclement weather.

Another object of the invention resides in the provision of a collapsible tent frame which is light in weight and inexpensive in manufacture, is easily adjusted to facilitate enlargement or contraction of capacity as needed, and which can be easily and quickly assembled and erected by one person without special tools, and when collapsed and folded comprises but five sections.

A further object of the invention consists in providing a collapsible tent frame in which the ridge pole may be adjusted to take care of either slack or shrinkage in the canvas covering.

A still further object of the invention resides in the provision of a tent frame having foldable end sections which will simplify erection due to a minimum number of parts and the elimination of arch and brace members which ordinarily offer considerable interference to the erection of such sections.

Other objects and advantages of the invention will be apparent from the following description when taken in connection with the accompanying drawings, in which,

Figure 1 is a perspective view of the collapsible tent frame in erect position, the flexible covering being merely indicated by dot and dash lines.

Figure 2 is a plan view of one of the end sections in collapsed condition ready for transportation.

Figures 3 and 4 are end views of a collapsed end section, looking in the direction of the arrows 3—3 and 4—4 respectively.

Figure 5 is a perspective view of one of the corner fittings or braces.

Figure 6 is an enlarged fragmentary view of one of the side rails.

Figure 7 is an elevational view of a side rail in collapsed condition.

Figure 8 is an end view of the collapsed side rail looking in the direction of the arrows 8—8 (Figure 7).

Figure 9 is an elevational view of the ridge pole in collapsed position, parts being broken away.

Figure 10 is a perspective view of a fragment of the ridge pole showing one of the joints.

Figure 11 is a perspective view of a tent frame in set-up condition ready for use and having the canvas covering and awnings applied, and

Figure 12 is a fragmentary view of one of the tent posts with one of the awning brackets applied thereto.

Referring to the drawings in more detail the numeral 1 indicates the legs or posts of the collapsible tent frame. Each post comprises two tubular sections 2 and 3, the upper sections 3 being of smaller diameter and being telescopically received within the lower sections 2. The length of the posts and consequently the height of the tent frame may be varied by varying the position of the rods 3 within the tubes 2, and pins 4 are provided for locking the posts in their variously adjusted positions. The sections of the posts are shown as provided with series of transverse apertures for receiving the pins 4, but if desired these apertures may be located solely in the rods 3 and the exposed portions of the pins may bear against the upper ends of sections 2. Flexible chains or the like 5 may be employed for maintaining the pins 4 in proximity to their point of use.

The upper end of each leg or post 1 is pivotally secured to a bracket 6 as indicated at 7 and the bracket is provided with a depending extension 8 adapted to limit the outward movement of the post to a right-angular position with respect to the end frame or beam. A sleeve 9 is adapted to slide over the lower end of the stop or extension 8 to secure the post against pivotal movement and a set screw 10 serves to releasably secure the sleeve in position.

Securely connected to each bracket 6 is an end beam section 11, and the opposite ends of these sections, of which there are two at each end of the frame, are pivotally connected respectively to the hinged sections 12 and 13 of a bracket with which the ridge pole is associated. A set screw 14 is provided for locking the bracket sections in set-up position.

Rotatably and slidably mounted on each beam section 11 is a ring or collar 15 provided with a set screw 16 and a lug 17 to engage an eyelet in the canvas cover. Each of these collars is also provided with a hook portion 18 for engagement with the posts 1 when the end assembly is in collapsed condition as indicated in Figure 2. Other sleeves such as indicated at 19 may be secured to the end sections 11 and be provided

with lugs 20 for engagement with eyelets in the canvas cover.

Each corner bracket 6 is provided with a lateral tubular extension or socket 21 adapted to receive one end of a side rail or beam section 22 which is releasably secured by a set screw 23. Two sections 22 comprise each side rail, and their adjacent ends are connected to the hinged sections of a bracket 24. A set screw 25 serves to lock the bracket in set-up position. The side rails are provided with rigidly spaced collars 26 having lugs 27 for engaging eyelets in the tent covering.

The ridge pole for the tent frame comprises an intermediate horizontal section 30 and inclined end sections 31. These end sections are secured to the intermediate section by pivoted fixtures 32, and set screws 33 serve to releasably hold the fixtures in extended position. The outer ends of the sections 31 of the ridge pole are received in sockets 34 formed on the brackets 12-13 of the end assembly, and set screws 35 are employed for securing the ridge pole in its assembled relation with the end structure.

It will be noted that the sockets 34 are inclined upwardly and it should be pointed out that they are of sufficient length to permit a longitudinal adjustment of the ridge pole sections 31. By this means it will be apparent that the pole may be so adjusted as to take care of any slack or shrinkage which may occur in the tent covering.

It is usually desirable to provide awnings or extensions at the sides or ends of the tent and for this purpose supplemental frames such as indicated in Figure 11 may be applied to the main frame. For this purpose socketed brackets 36 may be slidably mounted on the posts 1 and secured in any desired adjusted positions by means of set screws 37. The sockets of these brackets serve to receive the ends of the supplemental frames for the awnings or extensions.

The tent frame proper as thus constituted is composed of five units; that is, the two foldable end assemblies, the two foldable side rails or beams, and the foldable ridge pole. A sixth unit will of course be necessary if the awning or extensions just described, are employed.

From the above description and the attached drawings it will be apparent to those skilled in the art that I have devised an exceedingly simple collapsible tent construction which is easily erected or collapsed by a single operator and without the use of special tools, that the construction is such as to permit of a very minor adjustment of the ridge pole so as to take up slack or allow for shrinkage in the canvas covering, and that the entire device comprises only five or six units when collapsed and ready for shipment.

In accordance with the patent statutes I have described what I now believe to be the preferred form of construction but it will be understood that various minor changes may be made in structural details without departing from the spirit of the invention, and it is intended that such changes be included within the scope of the appended claims.

What is claimed is:

1. A tent frame structure including a plurality of supporting posts, side and end beams secured to said posts, a ridge pole including downwardly inclined ends and upwardly inclined sockets mounted on the end beams for receiving the inclined ends of the ridge pole;

2. A tent frame structure including a plurality

of supporting posts, side and end beams secured to said posts, a ridge pole including downwardly inclined ends, upwardly inclined sockets mounted on the end beams for receiving the inclined ends of the ridge pole, and means for adjustably securing the inclined ends of the ridge pole within the sockets.

3. A tent frame structure including a plurality of supporting posts, side and end beams secured to said posts, a ridge pole including a horizontal portion and downwardly inclined end portions, and upwardly inclined sockets mounted on the end beams for receiving the inclined ends of the ridge pole.

4. A tent frame structure including a plurality of supporting posts, side and end beams secured to said posts, a ridge pole including an intermediate portion and pivotally connected end portions, and upwardly inclined sockets secured to the end beams for receiving the pivoted end portions of the ridge pole.

5. A tent frame structure including a plurality of supporting posts, side and end beams secured to said posts, a ridge pole including an intermediate portion and pivotally connected end portions, upwardly inclined sockets secured to the end beams for receiving the end portions of the ridge pole, and means for adjustably securing the end portions within the sockets.

6. A tent frame structure including end beams, each of said end beams comprising two sections, a bracket formed of hinged sections to which the adjacent ends of the beam sections are connected, a socket secured to each of said brackets, and a ridge pole having its ends secured in said sockets.

7. A tent frame structure including end beams, each of said end beams comprising two sections, a bracket formed of hinged sections to which the adjacent ends of the beam sections are connected, an upwardly inclined socket secured to each of said brackets, and a ridge pole including a central section and downwardly inclined end sections adapted to be received in said sockets.

8. A tent frame structure including end beams, each of said end beams comprising two sections, a bracket formed of hinged sections to which the adjacent ends of the beam sections are connected, an upwardly inclined socket secured to each of said brackets, a ridge pole including a central section and downwardly inclined end sections adapted to be received in said sockets, and means for adjustably securing the end portions within the sockets.

9. A tent frame structure including end beams, each of said end beams comprising two sections, a bracket formed of hinged sections to which the adjacent ends of the beam sections are connected, an upwardly inclined socket secured to each of said brackets, a ridge pole including a central horizontal section and end sections pivotally connected to the respective ends of the central section, and adapted to be received in said sockets, and means for adjustably securing the end portions within the sockets.

10. A tent frame structure comprising foldable end assemblies, foldable side beams adapted to be connected to the end assemblies to provide a main frame, a ridge pole, and means for varying the vertical position of the ridge pole with respect to the main frame.

11. A tent frame structure comprising foldable end assemblies, foldable side beams adapted to

be connected to the end assemblies to provide a main frame, a ridge pole including downwardly inclined end portions, and means for varying the vertical position of the ridge pole with respect to the main frame.

12. A tent frame structure comprising side and end beam members, brackets to which said beam

members are connected, foldable telescopically arranged supporting posts connected to said brackets, sockets mounted on the end beams and a ridge pole having downwardly inclined end portions adapted to engage said sockets.

DWIGHT GOODMAN.