

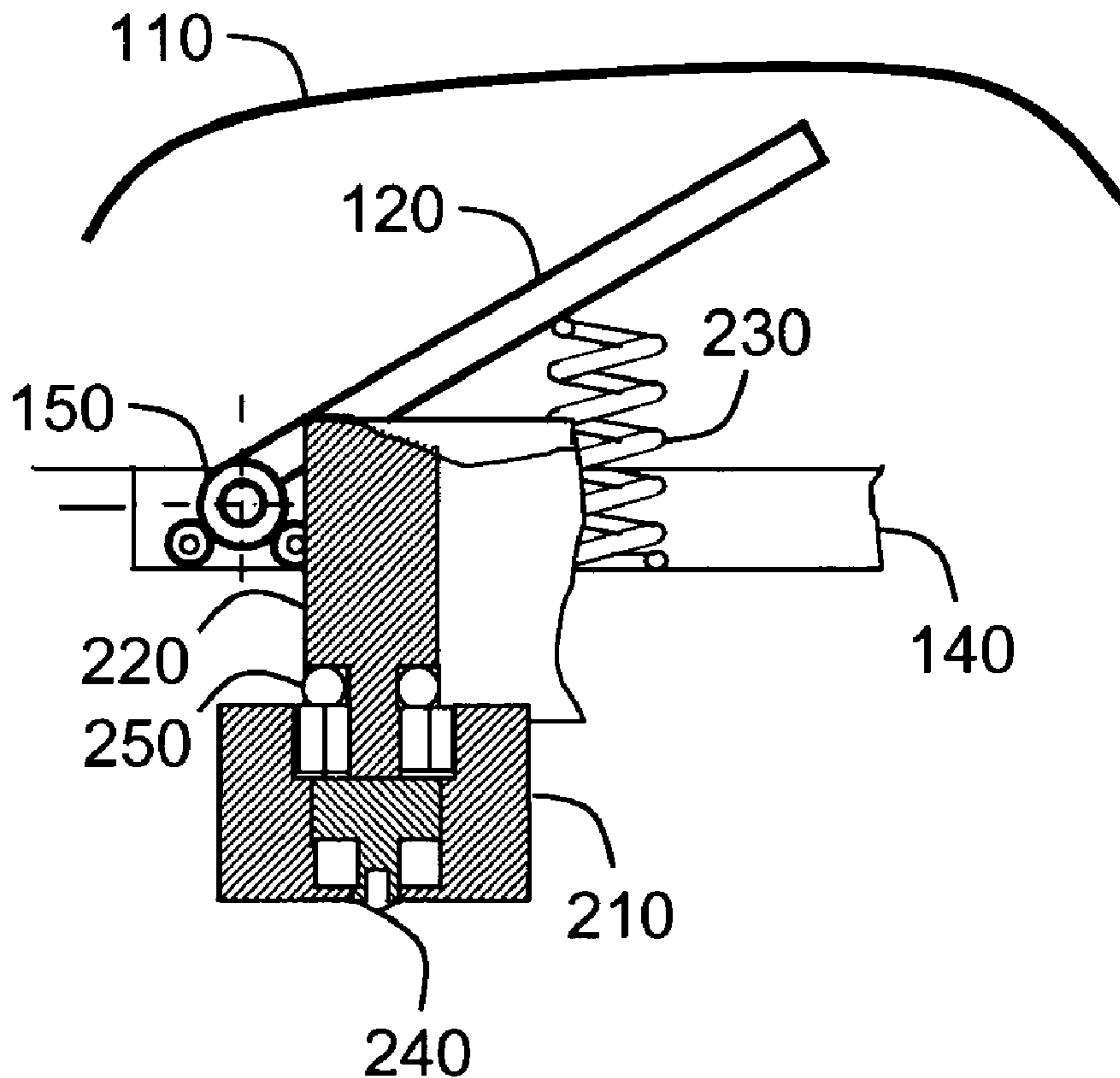

(86) Date de dépôt PCT/PCT Filing Date: 2007/09/20  
 (87) Date publication PCT/PCT Publication Date: 2008/03/27  
 (45) Date de délivrance/Issue Date: 2010/04/06  
 (85) Entrée phase nationale/National Entry: 2009/03/10  
 (86) N° demande PCT/PCT Application No.: IL 2007/001165  
 (87) N° publication PCT/PCT Publication No.: 2008/035348  
 (30) Priorité/Priority: 2006/09/20 (US60/845,772)

(51) Cl.Int./Int.Cl. *F03G 7/08* (2006.01),  
*E01F 9/047* (2006.01), *H02K 7/02* (2006.01),  
*H02K 7/18* (2006.01)  
 (72) Inventeur/Inventor:  
 CHEN, RON, IL  
 (73) Propriétaire/Owner:  
 INNOVATIVE PATENTS LTD., IL  
 (74) Agent: NELLIGAN O'BRIEN PAYNE LLP

(54) Titre : CONVERTISSEUR D'ELECTRICITE DES VEHICULES EN CIRCULATION INTEGRE DANS UNE BOSSE DE LA ROUTE  
 (54) Title: VEHICULAR MOVEMENT ELECTRICITY CONVERTER EMBEDDED WITHIN A ROAD HUMPS



(57) Abrégé/Abstract:

A system for converting vehicular movement into electricity while serving as a road hump at the same time. The linear motion of the vehicles is transformed by the device into rotational motion and finally converted into electric power. The system comprises a semi-

(57) **Abrégé(suite)/Abstract(continued):**

flexible cover strip lying across the path of vehicular traffic, covering the rest of the system, which is encapsulated within a housing embedded in the ground. The cover is connected to a generator via a wing or wings and a mechanism or mechanisms comprising a fly wheel, a rotor, a stator and a clutch. Passing vehicles push the cover strip down, causing the wings to depress, and engaging a clutch that transfers a rotational motion to the rotor, eventually, the rotor drives an electro-magnetic generator. The electro-magnetic generator converts the rotational motion of the rotor into electrical power.

(12) INTERNATIONAL APPLICATION PUBLISHED UNDER THE PATENT COOPERATION TREATY (PCT)

(19) World Intellectual Property Organization  
International Bureau(43) International Publication Date  
27 March 2008 (27.03.2008)

PCT

(10) International Publication Number  
**WO 2008/035348 A2**(51) International Patent Classification:  
*B60W 30/18* (2006.01)

(21) International Application Number:

PCT/IL2007/001165

(22) International Filing Date:

20 September 2007 (20.09.2007)

(25) Filing Language:

English

(26) Publication Language:

English

(30) Priority Data:

60/845,772 20 September 2006 (20.09.2006) US

(71) Applicant (for all designated States except US): **INNOVATIVE PATENTS LTD.** [IL/IL]; 15 Hilel Yafe St., 38203 Hadera (IL).

(72) Inventor; and

(75) Inventor/Applicant (for US only): **CHEN, Ron** [IL/IL]; Bait 10, 18 Hazait St., 30900 Zichron Ya'acov (IL).(74) Agent: **APPELFELD ZER FISHER**; B.S.R Tower 1, Floor 16, 2 Ben Gurion St., 52573 Ramat Gan (IL).

(81) Designated States (unless otherwise indicated, for every kind of national protection available): AE, AG, AL, AM, AT, AU, AZ, BA, BB, BG, BH, BR, BW, BY, BZ, CA, CH, CN, CO, CR, CU, CZ, DE, DK, DM, DO, DZ, EC, EE, EG, ES, FI, GB, GD, GE, GH, GM, GT, HN, HR, HU, ID, IL, IN, IS, JP, KE, KG, KM, KN, KP, KR, KZ, LA, LC, LK, LR, LS, LT, LU, LY, MA, MD, ME, MG, MK, MN, MW, MX, MY, MZ, NA, NG, NI, NO, NZ, OM, PG, PH, PL, PT, RO, RS, RU, SC, SD, SE, SG, SK, SL, SM, SV, SY, TJ, TM, TN, TR, TT, TZ, UA, UG, US, UZ, VC, VN, ZA, ZM, ZW.

(84) Designated States (unless otherwise indicated, for every kind of regional protection available): ARIPO (BW, GH, GM, KE, LS, MW, MZ, NA, SD, SL, SZ, TZ, UG, ZM, ZW), Eurasian (AM, AZ, BY, KG, KZ, MD, RU, TJ, TM), European (AT, BE, BG, CH, CY, CZ, DE, DK, EE, ES, FI, FR, GB, GR, HU, IE, IS, IT, LT, LU, LV, MC, MT, NL, PL, PT, RO, SE, SI, SK, TR), OAPI (BF, BJ, CF, CG, CI, CM, GA, GN, GQ, GW, ML, MR, NE, SN, TD, TG).

**Published:**

— without international search report and to be republished upon receipt of that report

(54) Title: VEHICULAR MOVEMENT ELECTRICITY CONVERTER EMBEDDED WITHIN A ROAD HUMPS

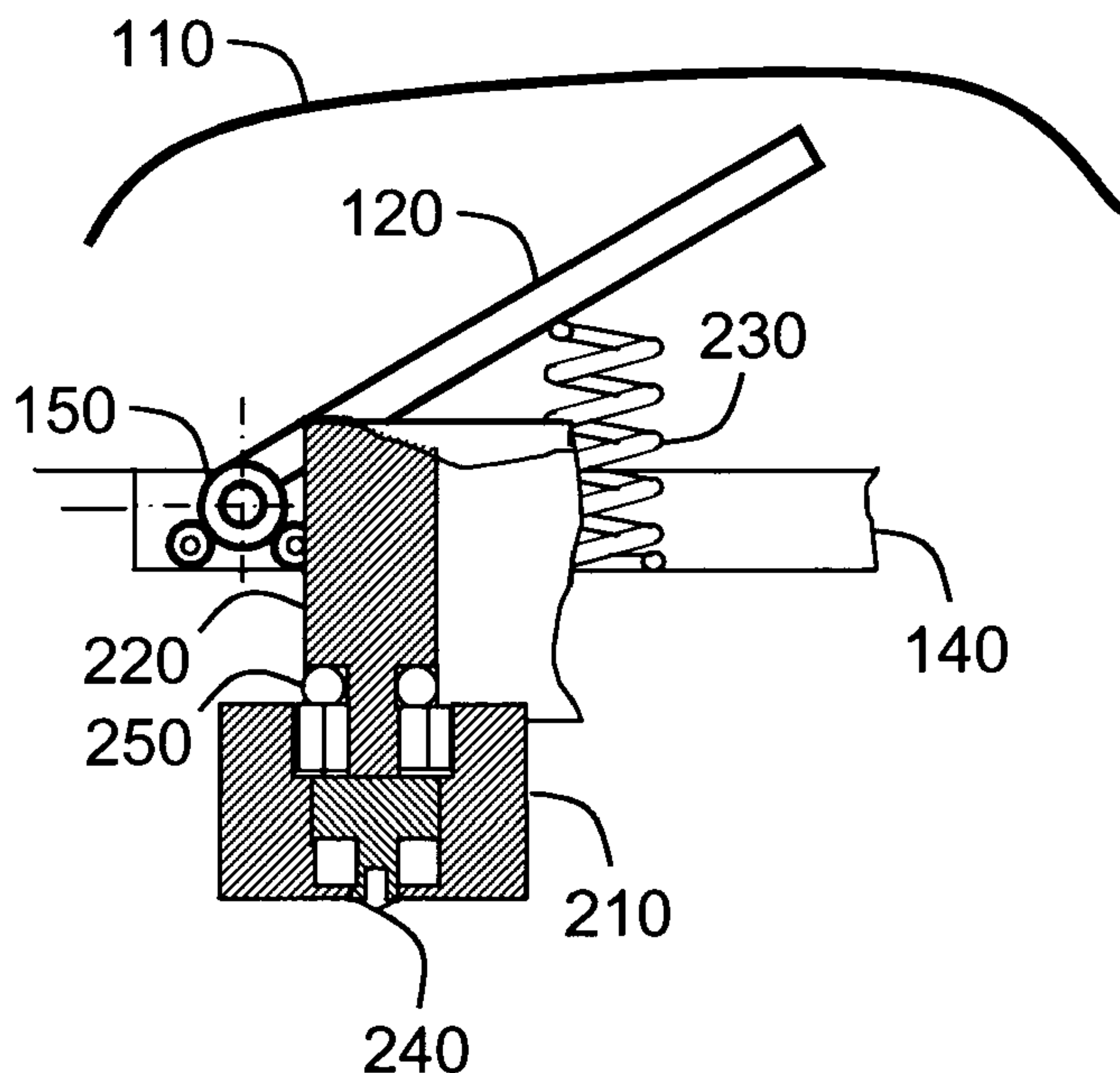

(57) Abstract: A system for converting vehicular movement into electricity while serving as a road hump at the same time. The linear motion of the vehicles is transformed by the device into rotational motion and finally converted into electric power. The system comprises a semi-flexible cover strip lying across the path of vehicular traffic, covering the rest of the system, which is encapsulated within a housing embedded in the ground. The cover is connected to a generator via a wing or wings and a mechanism or mechanisms comprising a fly wheel, a rotor, a stator and a clutch. Passing vehicles push the cover strip down, causing the wings to depress, and engaging a clutch that transfers a rotational motion to the rotor, eventually, the rotor drives an electro-magnetic generator. The electro-magnetic generator converts the rotational motion of the rotor into electrical power.

WO 2008/035348 A2

VEHICULAR MOVEMENT ELECTRICITY CONVERTER EMBEDDED WITHIN A  
ROAD HUMP

FIELD OF THE INVENTION

5 [0001] The present invention relates generally to kinetic-electrical energy conversion systems, and more particularly to the conversion of the energy of passing vehicles into electricity.

BACKGROUND OF THE INVENTION

10 [0002] Traditional methods of converting kinetic energy into electricity are known to be embedded in roads for generating electricity from passing vehicles. US patent No. US 6,767,161 discloses such system. The system generates power from the passage of motor vehicles. The vehicular movement is transformed into rotational energy of a turbine located on the side of the road.

15 [0003] US patent no. US 6,756,694 describes an apparatus for generating power from vehicular traffic. In this reference, the energy of moving vehicles is transferred to a power generator by fluid flow, such that the conversion involves a form of a hydraulic system.

20 [0004] International patent application No. W02004023621 discloses a system for generating energy on the road from the vehicles movement on the road. The system comprises a driving cylinder laid across the road in such a way that vehicles pass over it, an electrical generator for generating electricity when its axis is rotated, and a transmission unit for transferring rotational motion from the driving cylinder to the generator axis.

25 SUMMARY OF THE INVENTION

[0005] The disclosed system takes the idea of utilizing on-road electricity generators further. It is observed that the traditional vehicular movement energy converters create a substantial obstacle for the passing vehicles. Any driver passing over such a converter is required to slow down or risk damaging his or her vehicle. The disclosed system transforms this disadvantage  
30 into an advantage by embedding the vehicular movement converter within a road hump.

[0006] Road humps (aka speed bumps or "silent policeman") are widely used for road traffic regulation, especially in urban road systems. Usually they are built as a protrusion above road

level. The humps make drivers slow down in potentially dangerous places. The vehicle goes up on the hump and down from it during the motion. The kinetic energy of the vehicle is transformed into potential energy and is subsequently transformed back into kinetic energy.

5 [0007] According to the present invention, the potential energy at the intermediate stage could be utilized by making the road hump move up and down. The disclosed system converts the potential energy into electric power, which can be used for streetlights or other electric appliances.

10 [0008] The present invention pertains an improvement of previous art by combining a simplified process for energy generation and a road safety system, and improves the use of said electrical energy by adding a bi-directional electricity meter. The combination of these three features in the disclosed system reduces costs and maintenance expenses.

15 [0009] In embodiments of the invention, each time a vehicle passes over and depresses the cover strip, a wing that is located within the housing is pushed down. This engages the clutch, which transfers a rotational motion to the rotor; the rotor drives the electro-magnetic generator. The electro-magnetic generator converts the rotational motion of the rotor into electrical power. The electricity generated by the device is then available for either immediate use or storage.

20 [0010] In embodiments, the electricity produced by the present invention is enough to power streetlights or other electric devices, and can be redirected to power grid by the use of bi-directional meter so that accumulated energy consumed by device owner is reduced accordingly. The produced electric power could be utilized for public or personal needs.

25 [0011] In embodiments, the disclosed system comprises both external parts and parts that are hidden beneath road surface. The external part is made of a semi-flexible cover strip running across a lane or multiple lanes of traffic. The cover lies over the housing of the device. The housing contains an electric power generator and a mechanism, which transforms linear motion of vehicles into rotational motion of the electric power generator.

#### BRIEF DESCRIPTION OF DRAWINGS

30 [0010] The subject matter regarded as the invention will become more clearly understood in light of the ensuing description of embodiments herein, given by way of example and for purposes of illustrative discussion of the present invention only, with reference to the accompanying drawings (Figures, or simply "FIGS."), wherein:

[0011] FIG. 1 is a schematic diagram showing the system according to the present invention without the electrical conversion means;

[0012] FIG. 2 is a schematic diagram showing the system according to the present invention with the electrical conversion means;

5 [0013] FIG. 3 is diagram showing an exemplary deployment of the present invention in a traffic roundabout;

[0014] FIG. 4 is diagram showing an exemplary deployment of the present invention in a multi lane road; and

10 [0015] FIG. 5 is diagram showing an exemplary deployment of the present invention in T-junction on the left turn lane.

[0016] The drawings together with the description make apparent to those skilled in the art how the invention may be embodied in practice.

[0017] Further, where considered appropriate, reference numerals may be repeated among the figures to indicate corresponding or analogous elements.

15

#### DETAILED DESCRIPTION OF THE INVENTION

[0018] FIG. 1 shows a schematic diagram of the system according to the present invention without the electrical conversion means. The system comprises an arced cover strip 110 that runs across a traffic lane or multiple lanes. The cover strip 110 is mounted upon a housing 140  
20 that is embedded within the road, directly under the cover strip. The cover strip 110 is abutted upon a wing 120 that is attached to an axis of rotation 150 also located within the housing 140. The upper end of the wing 120 touches the cover strip above the road level. The wing 120 is also connected to a spring 130, such as a compression spring. Whenever the cover strip 110 is pressed down, the wing 120 rotates around the axis 150 and is subsequently returned to its  
25 original position by the spring 130.

[0019] According to some embodiments of the invention, the wing 120 may be comprised of a plurality of adjacent wings that may be connected together in a telescopic manner.

[0020] FIG. 2 shows a schematic diagram of the system according to the present invention now with the electrical conversion means depicted. The system further comprises, in addition to the  
30 aforementioned description of FIG. 1, a fly wheel and a rotor 210, a stator 220, centered within the rotor 210, a spring 230 (variant of 130) connecting the wing 120 and the housing 140, an electro-magnetic generator 240 connector to the rotor and a clutch 250. The clutch 250

transfers the rotational motion to flywheel and rotor **210** which activate in turn the electro-magnetic generator **240**. Vehicles driving over the cover strip **110** press it down causing the rotor to rotate and drive the generator to generate alternating current which is then modified and passed on. When the wing **120** is released, the spring **230** returns it back to the initial position.

5 And.

[0021] According to some embodiments of the invention when the system, a relaxed phase (i.e., no vehicle over the cover strip) the cover strip is protruding above the surface of the road necessitating a driver to slow down.

10 [0022] According to some embodiments of the invention the electricity produced by the generator is then transferred to power supply connected to a stabilizer for accumulating the energy to be used for any electric powered appliance. Alternatively, it may be redirected to power grid via bi-directional power meter.

15 [0023] According to some embodiments of the invention, apart from the cover strip **110**, all the system's components are located inside the housing **140**, under road surface, thus imitating a the size and shape of a standard road hump.

[0024] According to some embodiments of the invention, multiple vehicles passing one after another transfer a small amount of its kinetic energy to the device, ensuring, with the use of said flywheel **210** a smooth and constant rotation of the rotor. This results in a stable and permanent electricity generation.

20 [0025] According to some embodiments of the invention the electro-magnetic generator is a generator standard to the art. The electricity generated by this operation is then transferred, using traditional technology and components (i.e. batteries, regulators, DC motors etc), to connected streetlights or any other electric power appliance or holding station. Alternative connectivity method is based on synchronized regulator that enables a direct connection of  
25 generated electricity to power grid, via a bi-directional power meter. Using the present system acts as a "power station", while generated power is credited to the system's owner.

[0026] According to some embodiments of the invention, the cover strip **110** encases three layers of material that provide strength and durability, that include rubber, composite material and a thin metal layer. The first layer is thin metallic layer. A second layer made of material  
30 that acts as a sound and vibration barrier encloses the steel layer. These two layers are then encased in a composite material. This results in a rigid but flexible material that will withstand

wear and heat generated by vehicles constantly riding across it as well as the resultant continuous flexing.

[0027] According to some embodiments of the invention the housing and most of the components contained therein are made of metal for robustness.

5 [0028] According to some embodiments of the invention, at its highest point, the cover strip sits approximately 9 cm above the surface of the road. In the arced position, the cover strip is at least 40 cm wide.

[0029] FIGS. 3, 4 and 5 show exemplary deployments for the present invention, FIG. 3 shows a roundabout 400 wherein the cover strips 110 (as well as the systems beneath them) are  
10 deployed on two roads leading to the roundabout. The deployment in this location may enable to regulate slowing down the speed while entering to a roundabout from a main road (the road where the cover strips have been placed).

[0030] FIG. 4 shows the deployment of the cover strips 110 on both sides of a dual lane road 400. This may be required in a place where slowing down is important for both directions (such  
15 as near a school).

[0031] FIG. 5 shows the deployment of a cover strip 110 on a T-junction 500, right before the left turn lane, wherein stopping is required more often than not. By deploying the system there-stopping and at least slowing down is necessitated.

[0032] According to a further embodiment of the present invention the system is integrated  
20 with a traffic velocity regulator. The flow of traffic and the amount of electricity that needs to be generated will determine the number of generators (and an equal number of wings) required and their exact position on traffic lanes.

[0033] Advantageously, the system as described above has a dual effect. First, it may be  
25 utilized as road humps for slowing the traffic down wherein the cover strip serves as a road hump platform. The depression of the wing occurs at any vehicle speed so that it covers a wide range of speeds. Second, low speed continuous traffic ensures constant motion of the rotor and lasting electricity generation. Thus, the integration of the device into road humps is especially efficient because of the fact that the device is designed to work in slow traffic regime. As an example, urban traffic can be considered, as well as toll-roads paying plaza and parking lots  
30 entrances and exits. The produced electricity can be directly utilized for streetlights, traffic lights or other appliance. This combination reduces the costs and maintenance expenses of the device.

[0034] In the above description, an embodiment is an example or implementation of the inventions. The various appearances of "one embodiment," "an embodiment" or "some embodiments" do not necessarily all refer to the same embodiments.

5 [0035] Although various features of the invention may be described in the context of a single embodiment, the features may also be provided separately or in any suitable combination. Conversely, although the invention may be described herein in the context of separate embodiments for clarity, the invention may also be implemented in a single embodiment.

10 [0036] Reference in the specification to "some embodiments", "an embodiment", "one embodiment" or "other embodiments" means that a particular feature, structure, or characteristic described in connection with the embodiments is included in at least some embodiments, but not necessarily all embodiments, of the inventions.

[0037] It is understood that the phraseology and terminology employed herein is not to be construed as limiting and are for descriptive purpose only.

15 [0038] The principles and uses of the teachings of the present invention may be better understood with reference to the accompanying description, figures and examples.

[0039] It is to be understood that the details set forth herein do not construe a limitation to an application of the invention.

20 [0040] Furthermore, it is to be understood that the invention can be carried out or practiced in various ways and that the invention can be implemented in embodiments other than the ones outlined in the description above.

[0041] It is to be understood that the terms "including", "comprising", "consisting" and grammatical variants thereof do not preclude the addition of one or more components, features, steps, or integers or groups thereof and that the terms are to be construed as specifying components, features, steps or integers.

25 [0042] If the specification or claims refer to "an additional" element, that does not preclude there being more than one of the additional element.

[0043] It is to be understood that where the claims or specification refer to "a" or "an" element, such reference is not to be construed that there is only one of that element.

30 [0044] It is to be understood that where the specification states that a component, feature, structure, or characteristic "may", "might", "can" or "could" be included, that particular component, feature, structure, or characteristic is not required to be included.

[0045] Where applicable, although state diagrams, flow diagrams or both may be used to describe embodiments, the invention is not limited to those diagrams or to the corresponding descriptions. For example, flow need not move through each illustrated box or state, or in exactly the same order as illustrated and described.

5 [0046] Methods of the present invention may be implemented by performing or completing manually, automatically, or a combination thereof, selected steps or tasks.

[0047] The term "method" may refer to manners, means, techniques and procedures for accomplishing a given task including, but not limited to, those manners, means, techniques and procedures either known to, or readily developed from known manners, means, techniques and  
10 procedures by practitioners of the art to which the invention belongs.

[0048] The descriptions, examples, methods and materials presented in the claims and the specification are not to be construed as limiting but rather as illustrative only.

[0049] Meanings of technical and scientific terms used herein are to be commonly understood as by one of ordinary skill in the art to which the invention belongs, unless otherwise defined.

15 [0050] The present invention can be implemented in the testing or practice with methods and materials equivalent or similar to those described herein.

[0051] In addition, citation or identification of any reference in the description of some embodiments of the invention shall not be construed as an admission that such reference is available as prior art to the present invention.

20 [0052] While the invention has been described with respect to a limited number of embodiments, these should not be construed as limitations on the scope of the invention, but rather as exemplifications of some of the embodiments. Those skilled in the art will envision other possible variations, modifications, and applications that are also within the scope of the invention. Accordingly, the scope of the invention should not be limited by what has thus far  
25 been described, but by the appended claims and their legal equivalents. Therefore, it is to be understood that alternatives, modifications, and variations of the present invention are to be construed as being within the scope and spirit of the appended claims.

## CLAIMS

What is claimed is:

1. A system for converting kinetic energy of vehicles passing along a traffic lane into electricity, said system comprising:
  - 5           - a cover strip positioned across the traffic lane;
  - a housing embedded into the ground under the traffic lane;
  - a main rotation axis;
  - a compression spring;
  - a wing connected at the upper end to the cover strip and at the second end to  
10       main rotation axis, said wing attached to the compression spring wherein the wing  
rotates as a result of the pressure applied upon the strip and returns to its upper position  
as a result of the compression spring power;
  - a generator coupled to the wing, wherein said generator is configured to  
convert the rotational movement into electricity;
  - 15           and wherein the system is integrated as a road hump such that in a relaxed phase  
the cover strip is protruding above the surface of the traffic lane necessitating a driver  
to slow down.
2. The system according to claim 1, further comprising:
  - 20           - a clutch engaged between the main rotation axis and the wing;
  - a flywheel and a rotor connected to the generator and operatively connected to  
the wing via the clutch;
  - wherein the clutch selectively engages and disengages the wing from the rotor  
allowing bi-directional conversion the wing's movement into a rotational movement of  
the rotor.
- 25       3. The system according to claim 1, wherein the cover strip is made of a combination of  
the following materials: rubber, metal, composite materials, ribbon compounds.
4. The system according to claim 1 wherein the wing is partly located above the surface of  
the traffic lane and the cover strip functions as a road hump.
5. The system according to claim 1 wherein system further comprises a traffic velocity  
30       regulator.
6. The system according to claim 1 wherein the generated electricity power is  
synchronized and regulated to be redirected to a power grid.

7. The system according to claim 1, wherein the electricity generated is stored over an electricity storage device for later use.
8. The system according to claim 1, wherein the electricity generated is delivered directly for consumption.
- 5 9. The system according to claim 1, further comprising a power meter such that the system operates as a mini power station whereby generated power is credited to the system's owner.

1/2

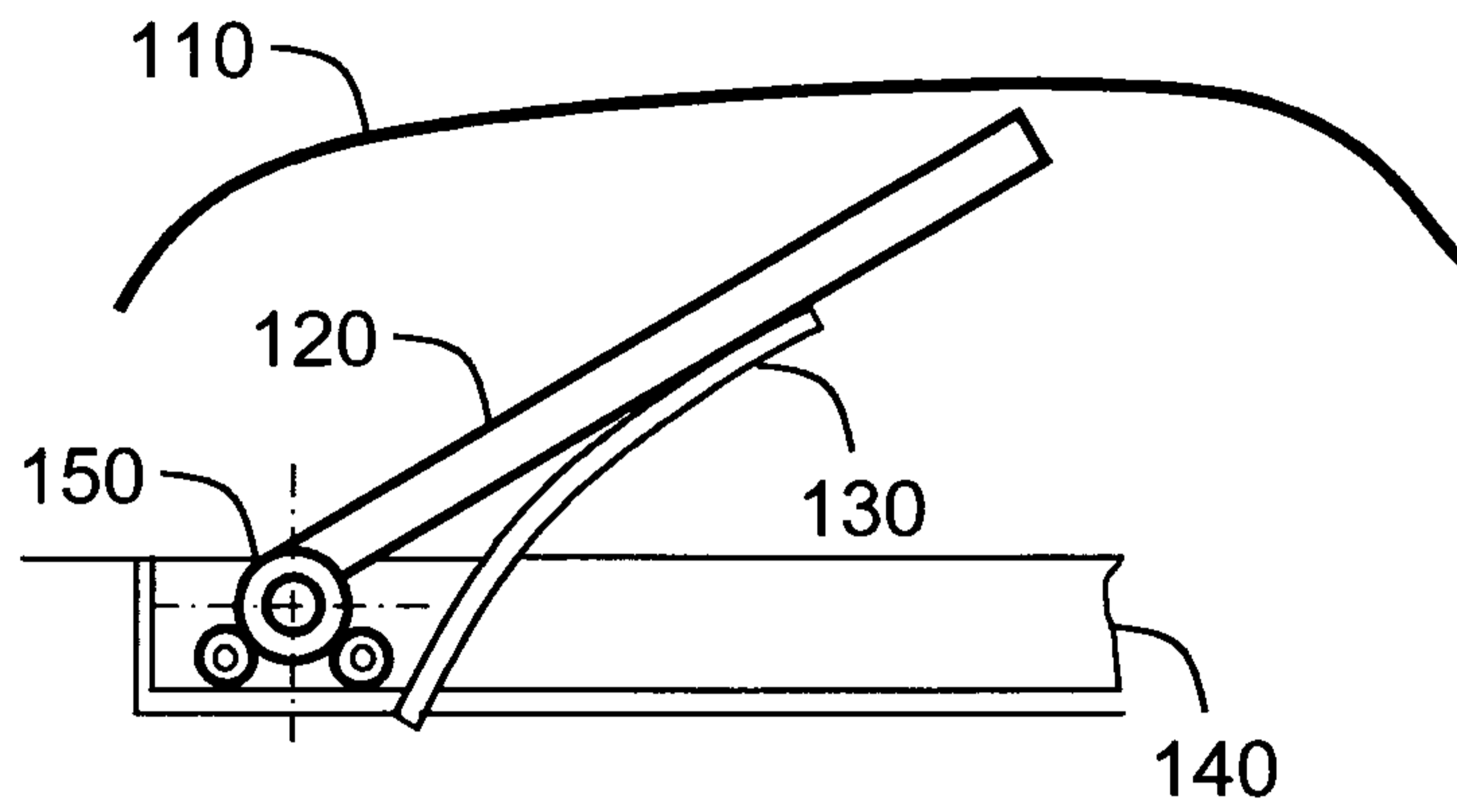
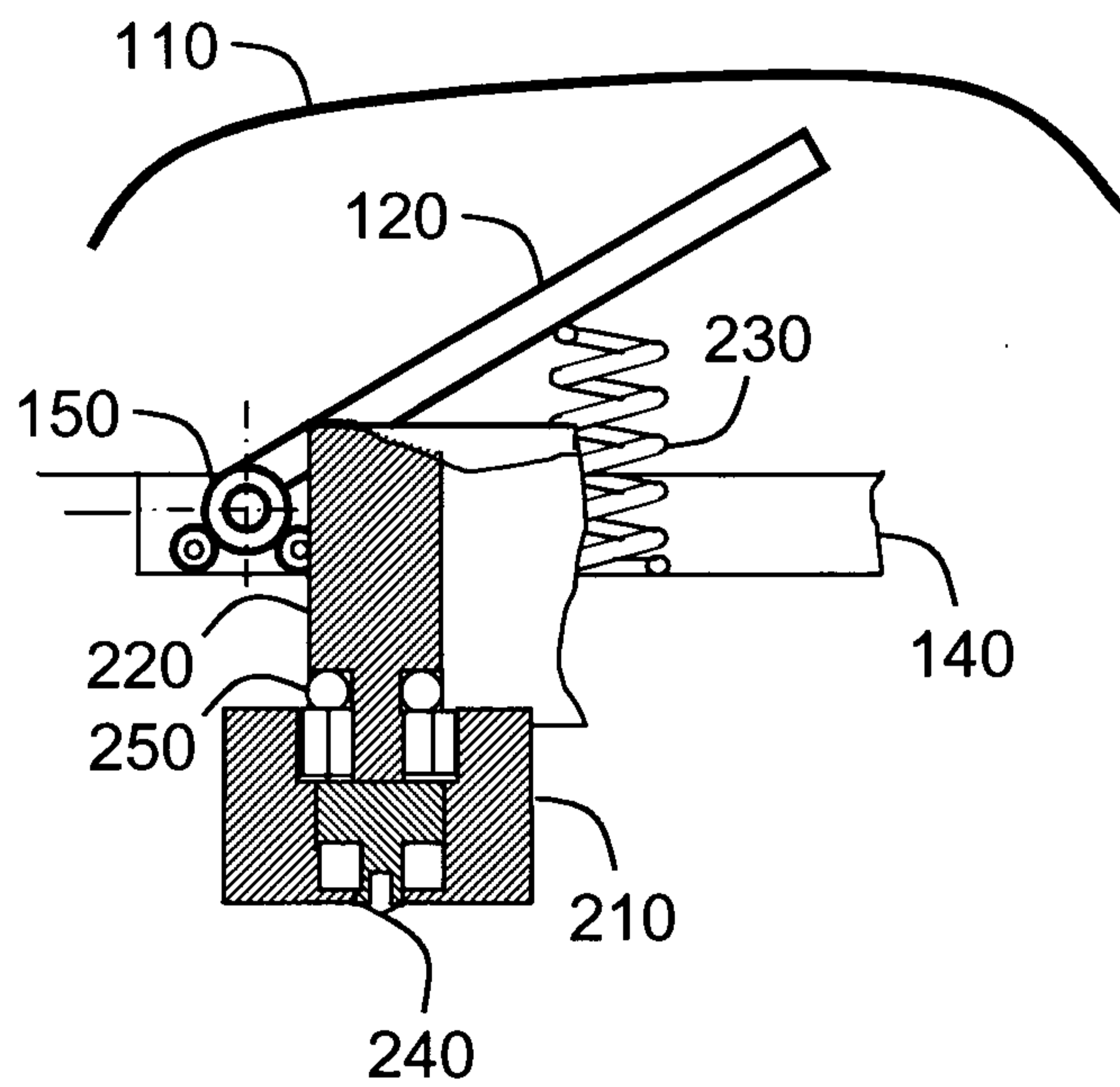
**FIG. 1****FIG. 2**

2/2

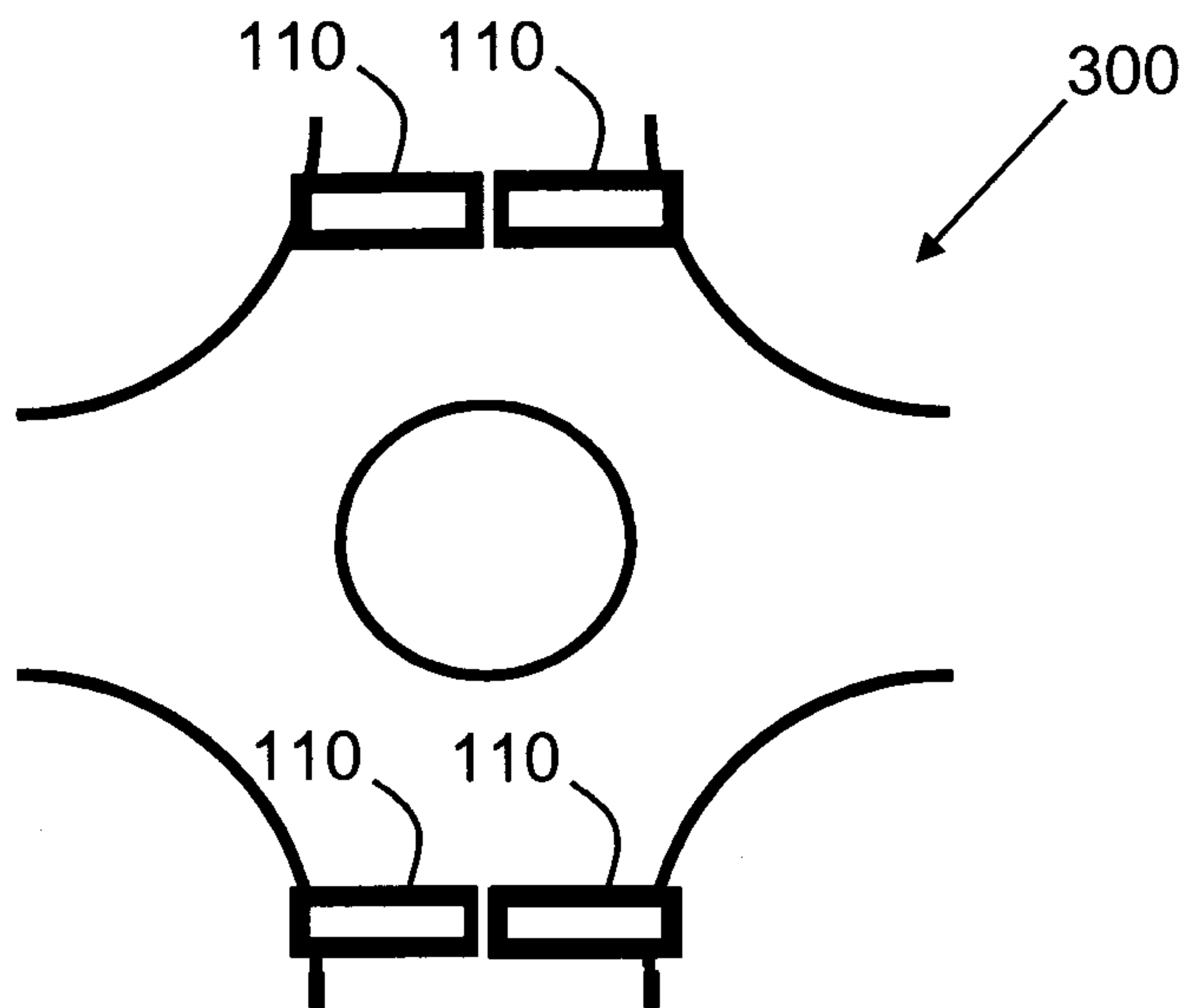

**FIG. 3**

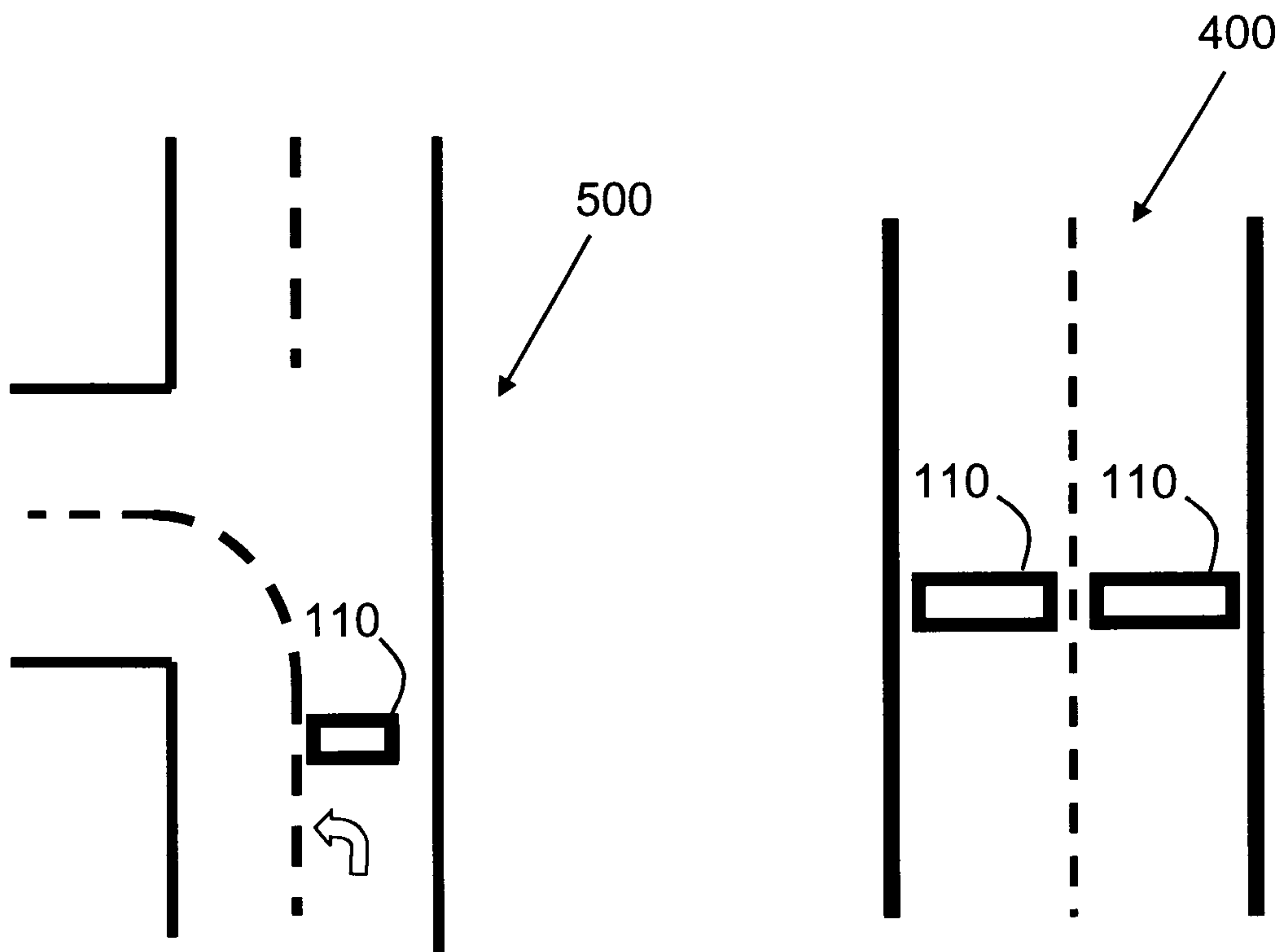

**FIG. 5**

**FIG. 4**

