



Europäisches Patentamt
European Patent Office
Office européen des brevets



(11) **EP 1 107 200 A2**

(12) **EUROPEAN PATENT APPLICATION**

(43) Date of publication:
13.06.2001 Bulletin 2001/24

(51) Int Cl.7: **G07F 11/12, G07F 11/22,
G07F 13/10**

(21) Application number: **00124486.2**

(22) Date of filing: **09.11.2000**

(84) Designated Contracting States:
**AT BE CH CY DE DK ES FI FR GB GR IE IT LI LU
MC NL PT SE TR**
Designated Extension States:
AL LT LV MK RO SI

(72) Inventors:
• **Personeni, Silvano**
24030 Mazzoleni, Bergamo (IT)
• **Mosconi, Claudio**
24100 Bergamo (IT)

(30) Priority: **02.12.1999 IT PN990087**

(74) Representative: **Giugni, Valter et al**
PROPRIA S.r.l.,
Via Mazzini 13
33170 Pordenone (IT)

(71) Applicant: **Necta Vending Solutions S.p.A.**
24030 Valbrembo, Bergamo (IT)

(54) **Automatic beverage vending apparatus with improved stick dispenser**

(57) Automatic beverage vending apparatus comprising a dispenser of the sticks used to mix the beverages in the cups.

The stick dispenser is formed by two columns (11, 12) joined to each other in a side-by-side arrangement, which are controlled by actuating means (18-24) so as to bring the respective stick dispensing outlet in correspondence of a pull-out unit (15).

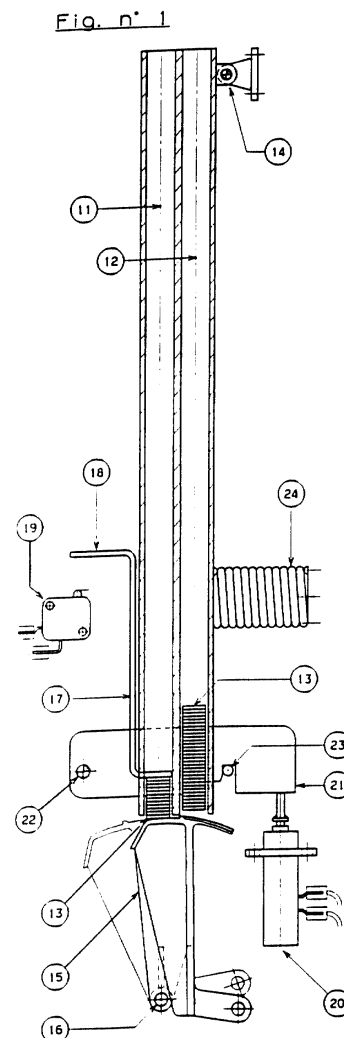

EP 1 107 200 A2

Description

[0001] The present invention refers to an automatic beverage vending apparatus, in particular a hot-beverage vending apparatus, provided with an improved stick dispenser so as to boost the capacity thereof.

[0002] Automatic hot-beverage vending apparatuses are usually provided, further to the devices and means needed to prepare and deliver the hot beverages, also with stick dispensing means. These sticks are dropped into the cups before the hot beverage is poured thereinto, and are used by the customer to mix the same beverages, in particular to dissolve sugar therein.

[0003] Prior-art stick dispensers are substantially constituted by a vertical column, inside which there is provided a housing that in its cross-section has the shape and the size of a stick. The sticks are stacked upon each other in this housing and are pulled out individually in view of being dropped into the cup. To such a purpose, at the lower end portion of the column there is arranged a pull-out unit formed by a pushing element, usually of the oscillating type, which is actuated by a motor or an electromagnet.

[0004] In prior-art stick dispensers, the only manner in which the capacity thereof can be increased, so as to be able to reduce the refilling frequency, ie. the frequency at which their load of sticks has to be restored, lies in increasing the height of the column that houses the sticks. However, a definite dimensional limit is given, beyond which it is practically impossible to go, and which is represented by the overall height of the vending apparatus. Furthermore, the higher the stack of sticks in the column, the more awkward and difficult the loading of the sticks thereinto and, above all, the removal of the lowest stick from the column, since the weight of the stack thereupon brings about an effect causing the sticks to practically adhere to each other. As a matter of fact, the sticks are made of a food-grade plastic material and tend to stick to each other.

[0005] It therefore is a purpose of the present invention to solve the above mentioned problem, and the solution consists in providing at least two stick-containing columns in a side-by-side arrangement, and in providing an improved device for automatically switching stick removal from the exhausted column over to the full one.

[0006] Such a solution enables the quantity of available sticks to be increased for a same height of the dispenser, ie. the vending apparatus.

[0007] Advantages and features of the present invention will be more readily and clearly understood from the description that is given below by way of non-limiting example with reference to the accompanying drawings, in which:

- Figure 1 is a vertical-section schematical view of a stick dispenser according to the present invention, in a first operating position thereof; and

- Figure 2 is a vertical-section schematical view of the stick dispenser illustrated in Figure 1, in a second operating condition thereof.

5 **[0008]** The stick dispenser according to the present invention, and illustrated in the above cited Figures, is constituted by two vertical columns 11, 12 that are so shaped in their interior as to be able to contain a stack of sticks 13 of a food-grade plastic material each. The two columns are firmly joined to each other in a side-by-side arrangement, and are supported by fulcrums, ie. pivotally, so as to be capable of oscillating about a pivot 14 fastened to the inner structure of the vending apparatus.

10 **[0009]** Below the columns 11 and 12 there is installed a pull-out unit 15 of a substantially per se known type, which is usually actuated by a motor or an electromagnet (not shown). This pull-out unit 15 is adapted to rotate about a pivot 16, so as to be able to pull out individually, ie. one at a time, the stick that each time comes to be positioned at the lower end portion of the respective stack 13 (Figure 1). The sticks, in fact, owing to both their own nature and the effect of their being so stacked, tend to adhere to each other, so that the need arises for a particular action to be exerted in order to remove them from the stack and let them drop into the cup before the beverage is dispensed.

15 **[0010]** According to the present invention, the first column 11 contains a properly shaped member 17 which weighs down on the stack of sticks and extends outside of the column itself with an arm 18. The member 17 follows the stack as it gradually sinks owing to the sticks being successively removed therefrom, until the arm 18 comes to interfere with a sensor 19, which at this point issues the signal indicating that the column 11 is completely empty.

20 **[0011]** The sensor 19 is preferably of an electric type and the signal that it issues is used to drive a switch-over device that is adapted to displace the two columns 11 and 12, so as to bring the lower end portion of the second column in a position in which it can interact with the above cited stick pull-out unit 15.

25 **[0012]** Such a switch-over device for so alternately changing the position of the columns is substantially constituted by an actuator 20, preferably of an electric type, which acts on a properly shaped hook 21. The hook 21 is hinged on to a pivot 22 fastened to the inner structure of the vending apparatus, and cooperates with a peg 23 that is rigidly connected to the columns 11 and 12. The hook 21 has a profile featuring a first and a second abutment 30, 31 (Figure 2) against which the peg 23 is able to alternatively come to rest. The columns 11 and 12 are therefore held in position by said peg 23 engaging the hook 21.

30 **[0013]** A thrust spring 24 is mounted on the rear side of the columns 11 and 12 in a substantially horizontal position and in a prestressed state, and exerts a continuous pressure on the same columns (leftwards in the

Figures).

[0014] As illustrated in Figure 2, when the arm 18 of the member 17 triggers the sensor 19 that drives the actuator 20, the latter lifts the hook 21 thereby causing it to rotate about the pivot 22. As a result, the columns 11 and 12, under the pushing action of the spring 24, are caused to displace (leftwards in Figure 2) by rotating about the fulcrum 14 until the peg 23, which is so disengaged from the first abutment 30, moves into engagement with the second abutment 31. In such a situation, it is the second stick-holding column 12 that shows its lower end portion in front of the stick pull-out unit 15.

[0015] Restoring the compressed state of the spring 24, by bringing the stick-holding columns back into the position shown in Figure 1, is done when the subsequent stick loading operation is carried out to refill the columns.

[0016] As this can be easily appreciated, the proposed solution is very simple, compact and reliable. It is of course within the capability of anyone skilled in the art to make any of a number of possible variants or modifications without departing from the scope of the present invention. So, for example, the columns 11 and 12 may be provided in a greater number than two and may be driven to displace rectilinearly along appropriate runners or slides, instead of rotating about the fulcrum 14. Furthermore, the actuator means can be of a mechanical or pneumatic type, or even of a combined mechanical and pneumatic type.

Claims

1. Automatic beverage vending apparatus, in particular for selling hot beverages, inside which there are provided means for dispensing the sticks used to mix the beverages in the cups, in which said stick dispensing means is substantially constituted by a properly shaped column (11), containing a stack of sticks (13), and a stick pull-out unit (15) mounted below the column to remove the lowest stick of the stack contained in the column, **characterized in that** at least a second stick-holding column (12) is provided in a side-by-side arrangement with said first column (11) firmly joined thereto, in which said columns are forced to displace by actuating means (18-24) so as to bring their respective stick outlet aperture in correspondence of said pull-out unit (15).
2. Automatic beverage vending apparatus according to claim 1, **characterized in that** said actuating means for displacing the stick-holding columns comprise sensor means (18, 19) associated to the first column (11) to detect the condition in which the same column becomes empty, and connected to actuator means (20-24) to trigger the displacement of the columns.
3. Automatic beverage vending apparatus according to claim 2, **characterized in that** said actuator means comprise at least a thrust member (24), in particular a spring, acting against the columns, and positioning means (21-23) to hold the columns in position with respect to the stick pull-out unit.
4. Automatic beverage vending apparatus according to claim 3, **characterized in that** said positioning means comprise a hook (21) oscillating about a fulcrum (22) and capable of being engaged by a peg (23) that is firmly joined to the stick-holding columns.
5. Automatic beverage vending apparatus according to any of the preceding claims, **characterized in that** the stick-holding columns (11- 12) are supported pivotally so as to be able to oscillate about a fulcrum (14) attached to the inner wall of the vending apparatus.

Fig. n° 1

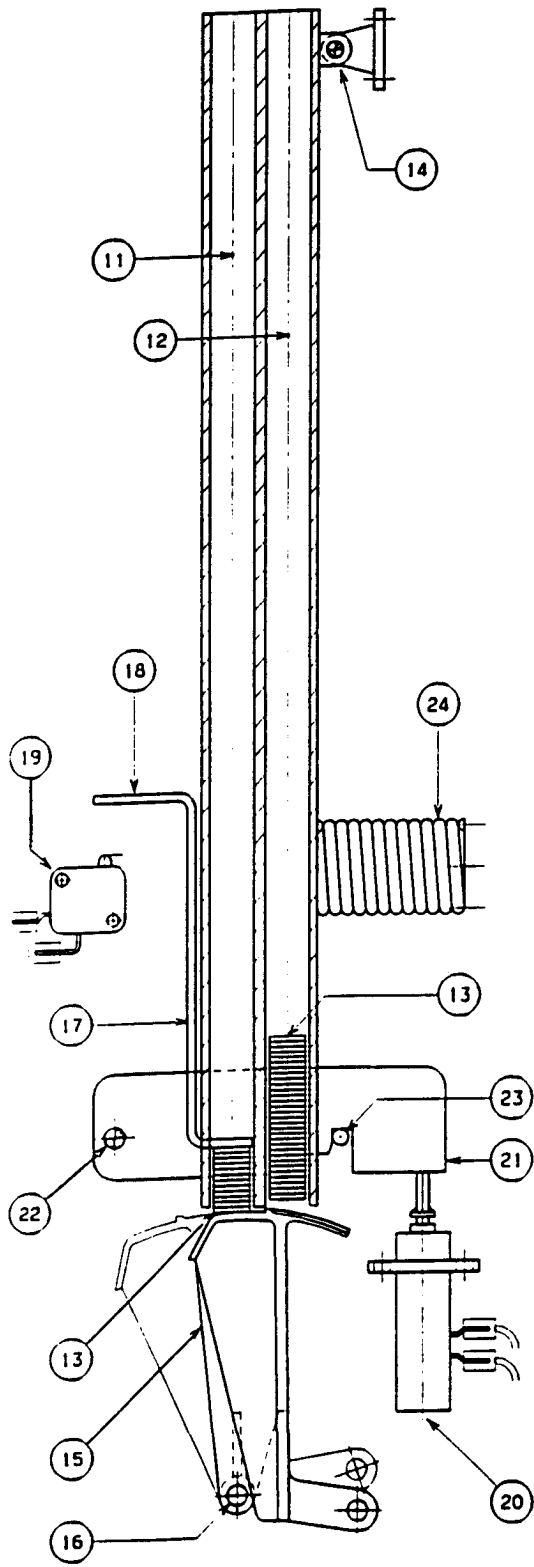

Fig. n° 2

