

(19) World Intellectual Property Organization
International Bureau



(43) International Publication Date
10 May 2002 (10.05.2002)

PCT

(10) International Publication Number
WO 02/36033 A1

- (51) International Patent Classification⁷: A61C 5/04 10634 South 390 East, Sandy, UT 84070 (US). LEWIS, Paul; 790 East Normandy Way, Midvale, UT 84047 (US).
- (21) International Application Number: PCT/US01/42676
- (22) International Filing Date: 12 October 2001 (12.10.2001)
- (25) Filing Language: English
- (26) Publication Language: English
- (30) Priority Data: 09/702,284 30 October 2000 (30.10.2000) US
- (71) Applicant: ULTRADENT PRODUCTS, INC. [US/US]; 505 West 10200 South, South Jordan, UT 84095 (US).
- (72) Inventors: FISCHER, Dan, E.; 10444 South Dimple Dell Road, Sandy, UT 84093 (US). RACHAL, Richard, N.;
- (74) Agents: NYDEGGER, Rick, D. et al.; Workman, Nydegger & Seeley, 1000 Eagle Gate Tower, 60 East South Temple, Salt Lake City, UT 84111 (US).
- (81) Designated States (*national*): AE, AG, AL, AM, AT, AU, AZ, BA, BB, BG, BR, BY, BZ, CA, CH, CN, CO, CR, CU, CZ, DE, DK, DM, DZ, EC, EE, ES, FI, GB, GD, GE, GH, GM, HR, HU, ID, IL, IN, IS, JP, KE, KG, KP, KR, KZ, LC, LK, LR, LS, LT, LU, LV, MA, MD, MG, MK, MN, MW, MX, MZ, NO, NZ, PL, PT, RO, RU, SD, SE, SG, SI, SK, SL, TJ, TM, TR, TT, TZ, UA, UG, UZ, VN, YU, ZA, ZW.
- (84) Designated States (*regional*): ARIPO patent (GH, GM, KE, LS, MW, MZ, SD, SL, SZ, TZ, UG, ZW), Eurasian patent (AM, AZ, BY, KG, KZ, MD, RU, TJ, TM), European patent (AT, BE, CH, CY, DE, DK, ES, FI, FR, GB, GR, IE,

[Continued on next page]

(54) Title: CUSHIONED, FIBER-COVERED DENTAL APPLICATORS

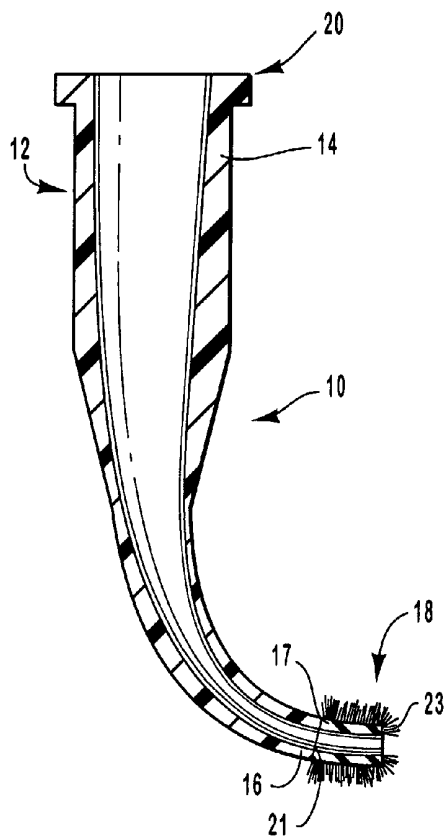

(57) Abstract: A dental instrument (10) is configured to be positioned adjacent the teeth and gums of a patient without injuring or causing pain to sensitive teeth or gums. The dental instrument (10) includes: i) a main body (12) having a proximal end (20) and a distal end (18), the main body (12) being configured to be grasped by a practitioner; ii) an elastomeric member (17) coupled to the distal end (18) of the main body (12) such that abutment of the elastomeric member (17) against the teeth or gums of a patient does not injure or cause pain to the teeth or gums; and iii) a plurality of fibers disposed on the elastomeric member (17). The fibers can be used to remove air bubbles from impression material, or for a variety of other uses. The instrument (10) may be in the form of an applicator or delivery tip, for example. The instrument (10) can have a non-slip gripping surface.



WO 02/36033 A1



IT, LU, MC, NL, PT, SE, TR), OAPI patent (BF, BJ, CF, CG, CI, CM, GA, GN, GQ, GW, ML, MR, NE, SN, TD, TG).

For two-letter codes and other abbreviations, refer to the "Guidance Notes on Codes and Abbreviations" appearing at the beginning of each regular issue of the PCT Gazette.

Published:

— *with international search report*

CUSHIONED, FIBER-COVERED DENTAL APPLICATORS

BACKGROUND OF THE INVENTION

1. The Field of the Invention

The present invention relates to cushioned delivery instruments for use in dentistry and medicine and other fields. More particularly, the present invention is directed to a dental instrument having a delivery tip portion configured for insertion into the mouth of a patient adjacent the teeth and gums of the patient.

2. The Relevant Technology

There are many important dental compositions that need to be efficiently delivered to tooth surfaces during dental restorative procedures. Such dental compositions include, for example, hemostatic agents, etchants, bonding agents, disinfectants, sealants, and for indirect impression making, impression materials. Applicators and syringes with associated delivery tips are often employed to deposit such compositions onto the teeth and gums of a patient. Dental instruments are also sometimes employed adjacent teeth and gums without depositing a composition thereon, such as when probing, cleaning, or examining a tooth or gum. Since dental instruments such as syringes and applicators are moved in such close proximity near teeth and gums of a patient, and sometimes even contact the teeth and gums of a patient, typical dental instruments can cause pain and irritation to the teeth and gums of the patient, particularly when the patient has injured or bleeding gums, or sensitive teeth, for example.

For instance, it is typical for practitioners to move a dental instrument adjacent the teeth and gums of a patient when the practitioner is removing air bubbles from dental compositions, such as impression materials, applied to the teeth and/or gums of a patient.

Impression materials are applied to the teeth and allowed to harden to thereby make an impression of the teeth. The hardened impression materials are then used to make a mold. When applying impression materials to a tooth, air bubbles can remain entrapped within the impression material, particularly when a syringe is used in dispensing the impression material. These air bubbles can prevent complete reproduction of detail in the impression material, resulting in a poor cast mold of the teeth.

The impression material is only useable for a few minutes once the base material and the catalyst material have been mixed. Thus, it is important to remove entrapped air

bubbles as soon as possible. In conventional delivery methods, after a quantity of impression material has been delivered around the prepared tooth, an air syringe is sometimes used to blow against the impression material. This can help to break up entrapped bubbles, but is not always predictable and can result in additional air bubbles becoming entrapped in the impression material. In addition, time is wasted addressing this issue while working time of the impression material is passing.

Although bristled dental instruments are highly useful for a variety of different purposes, such as removing air bubbles, one drawback relating to typical bristled instruments is that the instruments can contact and irritate sensitive root, nerve, and gum tissues. During use of bristled dental instruments, the instruments must necessarily be moved adjacent root, nerve, and gum tissues. In order to be effective, the instruments must be moved close enough to the teeth and gums that the bristles can be brushed against a composition placed on the teeth and gums.

Despite the greatest care exercised by the dentist, it is generally very difficult, if not impossible for the dentist to move a dental instrument adjacent the teeth and gums of a patient without, on occasion, accidentally abutting an end of the instrument against the teeth and gums. The contact of the instrument against the teeth and gums can be particularly painful in the event of an abscess, injury, sensitive gums, missing teeth, and other conditions potentially causing pain upon contact with a dental instrument.

Another challenge within the art relates to the movement of dental instruments into spaces between teeth and into or adjacent crevices and tight spaces within teeth, such as during delivery of dental materials therein. This challenge is increased when sensitive teeth and gums are involved.

What is therefore needed is a dental instrument and a method for using the dental instrument in a manner that does not injure the teeth and gums of a patient when the dental instrument contacts the teeth and gums. What is also needed is a dental instrument having at least some degree of fibrous covering without causing injury or pain in the event of contact between a dental instrument and the teeth or gums of a patient. What is also needed is a dental instrument that is readily placed into spaces between teeth and into or adjacent crevices and tight spaces within teeth, such as during delivery of dental materials therein or during a cleaning procedure.

SUMMARY OF THE INVENTION

This invention relates to the mounting of an elastomeric member on the main body of a dental instrument in order to conform to difficult tooth surfaces and/or prevent injury or pain upon the movement of the instrument against the teeth or gums of a dental patient. The main body, typically an elongate rigid body, and the elastomeric member form a cushioned dental instrument.

The cushioned dental instrument of the present invention may comprise, for example, a fiber-covered, cushioned instrument such as a delivery tip that is selectively coupled to a syringe. Optionally, the cushioned dental instrument may comprise a fiber-covered, cushioned dental applicator. As the practitioner moves the cushioned portion of the instrument close to the teeth and gums in order to apply or brush a dental composition, for example, the elastomeric member cushions any contact of the instrument against the teeth or gums.

One such cushioned dental instrument comprises: (i) a rigid, elongate, main body configured to be grasped by a practitioner; (ii) an elastomeric member coupled to the main body; and (iii) a plurality of flocking fibers electrostatically deposited on the elastomeric member. The fibers are affixed at an adhesion end thereof to the elastomeric member. The opposing free ends of the flocking fibers extend away from the elastomeric member.

The fibers of the dental tool permit an agitating action to remove air bubbles from the applied dental composition such as an impression material, reducing the amount of air entrapped within the impression material. The stimulation provided by the fibers also results in better adaptation of the applied material around tooth surfaces. The fibers may also be used in a brushing or scrubbing action, which is advantageous for working other dental compositions into the tissues.

As indicated, examples of the dental instrument include an applicator and a delivery tip. The cushioned member of a particular instrument may have a variety of different configurations, such as square, round, or a variety of different shapes. Grooves can be located in the cushioned member to enable the cushioned member to contract when it is placed between or adjacent teeth. Such grooves may have a variety of different configurations.

The dental tools of the present invention may be formed through the use of two or three color molding (or optionally, four, five or six color molding, for example, if many different materials are employed), adhesion, ultrasonic bonding, or through a variety of different techniques in which an elastomeric member is coupled to a rigid material.

A delivery tip of the present invention may be used to apply a dental composition to a tooth surface. One delivery tip comprises a tubular member, means for coupling the tubular member to a delivery device, an elastomeric member coupled to the tubular member, and a plurality of fibers coupled to the elastomeric member. An applicator of the present invention comprises a main body, an elastomeric member coupled to the main body, and a plurality of fibers coupled to the elastomeric member.

The body of the dental tool of the present invention, such as a delivery tip or applicator, may comprise a solid, rigid polypropylene, while the elastomeric portion may comprise a soft, elastomeric member, such as a thermoplastic elastomer, or a urethane, for example. Preferably, the dental instrument is made from a chemically inert material with respect to the dental compositions. The durometer of the elastomeric member may vary based on the durometer of the material to be delivered, with higher durometer elastomeric members being employed for higher durometer materials to be delivered, for example.

A handle of the dental tool may be formed through the use of a rigid material combined with an elastomeric member, thereby forming a non-slip grip, such as on the applicators of the present invention. Such a handle may be formed through two or three color molding, for example, and through the use of a number of different materials.

One delivery system of the present invention comprises a cushioned dental instrument and a delivery device coupled to the cushioned dental instrument. For example, a fiber-covered, cushioned delivery tip may be coupled to a syringe that has a reservoir and a plunger that selectively forces material from the reservoir. In another embodiment of a delivery system, an applicator system comprises a hollow main body and a reservoir movably coupled thereto. Upon movement of the applicator's main body with respect to the reservoir, a desired amount of material is delivered from the hollow main body.

Another major advantage of a cushioned dental instrument of the present invention is the ability of the cushioned instrument (with or without fibers) to accommodate irregularities in tooth and gum surfaces while still performing the delivery function desired. For example, a cushioned applicator is able to readily negotiate and deliver material into tight, awkward and irregular areas because the cushioned portion of the applicator is able to compress into and around such areas, thereby achieving a desired delivery function.

The applicator may also be readily used as a cleaning device to clean such irregular and awkward areas. The cushioning effect of the cushioning member also assists the applicator in cleaning hard to reach, awkward, and uneven spaces. Thus, since the cushioned dental instruments (e.g., applicators) of the present invention readily fit into and adjacent crevices on teeth, the instruments can also be conveniently used as cleaning devices to clean teeth, gums, and adjacent surfaces.

These and other features of the present invention will become more fully apparent from the following description and the appended claims, or may be learned by the practice of the invention as set forth hereinafter.

BRIEF DESCRIPTION OF THE DRAWINGS

In order to more fully understand the manner in which the above-recited and other advantages of the invention are obtained, a more particular description of the invention briefly described above will be rendered by reference to specific embodiments thereof which are illustrated in the appended drawings. Understanding that these drawings depict only typical embodiments of the invention and are not to be considered limiting of its scope, the invention will be described and explained with additional specificity and detail through the use of the accompanying drawings in which:

Figure 1A is a perspective view of a delivery system of the present invention comprising: (i) a hollow delivery tip of the present invention having a cushioned, fiber covered distal delivery end and (ii) a syringe shown adjacent to a proximal receiving end of the delivery tip in a cutaway view.

Figure 1B is a cross sectional side view of the delivery tip of Figure 1A with the side fins removed.

Figure 1C is a cross sectional, cutaway side depiction of the elastomeric tip member shown in Figure 1A with an optional adhesive coating shown in phantom lines.

Figure 2 is a cross-sectional side view of an alternate delivery tip of the present invention having a layer of elastomeric material disposed about a notched portion of the distal delivery end and a plurality of fibers coupled to the elastomeric material.

Figure 2A is a cross sectional, cutaway side view of an alternate delivery tip of the present invention comprising a layer of elastomeric material disposed about a rigid distal end of the delivery tip.

Figure 2B is another cross sectional, cutaway side view of an alternate delivery tip of the present invention comprising a layer of elastomeric material disposed about a rigid distal delivery end.

Figure 2C is a cross sectional, cutaway side depiction of the coating and distal end shown in Figure 2B with an optional adhesive coating shown in phantom lines.

Figure 2D is a cross sectional, cutaway side depiction of an optional coating and rounded distal end with an optional adhesive coating shown in phantom lines. Only one side is shown as flocked although both sides may be flocked.

Figure 3A is a perspective view of an applicator of the present invention having first and second cushioned, fiber covered tips on opposing ends thereof.

Figure 3B is a cross sectional side view of a cushioned tip of the applicator of Figure 3A comprising an elastomeric member that forms a distal cushioned tip member thereof.

Figure 3C is a cross sectional side view of another tip of the applicator of Figure 3A.

Figure 3D is a cross sectional, cutaway view of another applicator tip of the present invention.

Figure 4A is a cross sectional side view of an alternate applicator of the present invention having a cushioned, fiber-covered distal tip member coupled to a distal end of a main body thereof.

Figure 4B is a front view of the applicator of Figure 4A with the fibers removed.

Figure 4C is a cutaway depiction of the distal tip member of Figure 4A demonstrating various options for coupling fibers to the elastomeric distal tip member.

Figure 5A is a cross sectional, cutaway side view of an alternate cushioned, fiber covered applicator from that of Figure 4A having a coating of elastomeric material disposed about a rigid distal end of a main body thereof.

Figure 5B is a cutaway depiction of the distal tip member of Figure 5A demonstrating various options for coupling fibers to the elastomeric coating.

Figure 6A is a cross sectional side view of an alternate applicator of the present invention having a cushioned, fiber-covered distal tip member coupled to a distal end of a main body thereof.

Figure 6B is a front view of the applicator of Figure 6A with the fibers removed.

Figure 7A is a cross sectional, cutaway side view of an alternate cushioned, fiber covered applicator of the present invention having a coating of elastomeric material disposed on a rigid distal end of a main body thereof.

Figure 7B is a perspective, cutaway view of the applicator of Figure 7A with the fibers removed.

Figures 8A and 8B demonstrate cross sectional views of alternative applicators of the present invention having an elastomeric member that flexibly connects a proximal body portion to a distal body portion. In the embodiment of Figure 8B, the distal body portion has a cushioned distal end coupled thereto.

Figures 9A and 9B demonstrate cross sectional views of extended and compressed embodiments, respectively, of a delivery system comprising a hollow applicator and a reservoir in fluid communication with an internal passageway of the applicator.

Figures 10A and 10B demonstrate cross sectional views of alternative extended and compressed embodiments, respectively, of a hollow applicator having a reservoir in fluid communication with an internal passageway of the applicator.

Figures 11A-11C demonstrate a cushioned applicator tip member of the present invention having a spherical configuration with a groove therein, with flocking shown on the tip in the view of Figure 11B.

Figures 12A-12B demonstrate an alternate cushioned applicator tip member of the present invention having a spherical configuration with a groove therein.

Figures 13A-13B demonstrate an alternate cushioned applicator tip member of the present invention having a spherical configuration with a groove therein.

Figures 14A-14B demonstrate an alternate cushioned applicator tip member of the present invention having a spherical configuration with a groove therein.

5 Figures 15A-15B demonstrate an alternate cushioned applicator tip member of the present invention having a spherical configuration with a plurality of grooves therein.

Figures 16A-16B demonstrate an alternate cushioned applicator tip member of the present invention having a spherical configuration with a groove therein.

10 Figures 17A-17B demonstrate an alternate cushioned applicator tip member of the present invention having a V-shaped groove therein.

Figures 18A-18B demonstrate an alternate cushioned applicator tip member of the present invention having a paddle shaped configuration.

Figures 19-30 show various non-slip gripping portions of main bodies of applicators of the present invention.

15 Figure 31 is a perspective view of the body of the applicator featured in Figure 19 and having an elastomeric, spherically shaped distal tip member coupled to a rigid body member.

Figure 32 is a perspective view of the applicator shown in Figure 31 with a dental material placed thereon.

20 Figure 33 is a view of the applicator of Fig. 31 moved within the mouth of a patient such that fibers on the applicator contact and eliminate air bubbles within a delivered material.

DETAILED DESCRIPTION OF THE PREFERRED EMBODIMENTS

25 Examples of cushioned dental instruments are shown in the accompanying Figures. The cushioned dental instruments of Figures 1A-2B comprise a dental delivery tip. The cushioned dental instruments of Figures 3A-31 comprise dental applicators. Each of these dental instruments comprises a main body having a proximal end and a distal end. Coupled to the distal end is an elastomeric member that acts as a cushioning member. The cushioning member can assist the practitioner in orienting the dental
30 instrument into a difficult crevice or space, does not cause pain to teeth and gums, and

acts as an efficient cleaning member, complying with rough, uneven and difficult crevices and spaces.

With specific reference now to Figures 1A-1B, delivery tip 10 comprises a hollow tubular body 12 having a hollow proximal receiving end 14 and a hollow distal delivery end 16. Tubular body 12 has a passageway extending from an inlet orifice at proximal end 14 to an outlet orifice at the tubular distal end 16. A distal rim 21 is located at distal delivery end 16. Tubular body 12 may have a variety of different configurations such as elongate, curved, straight, or irregular configurations or a variety of other configurations known to those skilled in the art.

As shown, a hollow, tubular elastomeric tip member 17 is coupled to rim 21 of tubular body 12. Member 17 acts as a cushioning member, and is substantially more deformable than the material of which body 14 is comprised. For example, in one embodiment, body 14 comprises a rigid polypropylene or polyethylene, while tubular elastomeric cushioning member 17 comprises a deformable elastomeric material, such as a thermoplastic elastomer, rubber, polyurethane, another elastomeric adhesive material, or another material that is thick enough to have a cushioning effect.

In the embodiment of Figures 1A and 1B, tip 10 further comprises a series of fibers 18 coupled to elastomeric cushioning member 17, such as through electrostatic flocking. Fibers 18 can be employed to remove particles from the mouth of the patient, to remove bubbles from an impression material or other material, to manipulate, massage, or clean appliances, teeth, gums, or other portions of the mouth, or for a variety of other purposes. Delivery tip 10 is configured to be coupled to a delivery device, such as a syringe 19 and to direct material delivered from syringe 19 to a desired location within the mouth of a patient. An external thread 20 is an example of a means for coupling tubular member 12 to a delivery device. Through the use of thread 20, tubular member 12 can be releasably coupled to a delivery device, such as syringe 19 (e.g., by being coupled to mating threads on syringe 19). However, a variety of different means for coupling tubular member 12 to a delivery device may also be employed, such as internal threads (e.g., thread 22 of Fig. 2), male or female Luer-lock type attachment members, a configuration that allows a press fit attachment, or any other suitable arrangement understood by one skilled in the art in light of the disclosure herein.

Syringe 19 may have a variety of different configurations. In one embodiment, syringe 19 comprises a reservoir means (e.g., a barrel) for holding a quantity of a dental composition for restorative or reconstructive dental procedures and a means for controlled dispensing (e.g., a plunger) of the dental composition from the reservoir means. The plunger or other means for controlled dispensing also dispenses the dental composition through the delivery tip in order to apply in a precise, controlled fashion the dental composition to a small area, such as a relatively small region of a tooth surface that is to be restored or reconstructed.

Fibers 18 can have a variety of different lengths. In one embodiment, short and long fibers exist in a particular bundle of fibers such that the long fibers are supported by the short fibers. Optionally, fibers extend from distal rim 23.

Also as shown in Figures 2-2B, the elastomeric portion of the dental instrument of the present invention may be located on a variety of different portions of the main body of the dental instrument. In one embodiment, the elastomeric portion comprises a coating surrounding a rigid distal end portion, as shown in Figure 2. Figure 2 demonstrates an alternative delivery tip 30 of the present invention comprising a tubular body 31 having a hollow proximal receiving end 32 and a hollow distal delivery end 36. Distal delivery end 36 comprises a notched exterior portion. A surrounding elastomeric cushioning coating 38 is mounted on and extends about notched distal end 36. Elastomeric coating 38 comprises an elastomeric member, such as a thermoplastic elastomer or polyurethane as discussed above with respect to Figure 1B. Fibers 40 extend from elastomeric coating 38. Fibers 40 can be affixed to coating 38 in a variety of different manners, such as through electrostatic flocking.

Since coating 38 surrounds notched distal end 36, coating 38 forms a substantially seamless distal end of delivery tip 30. This is advantageous because tip 30 can readily move smoothly within the mouth of a patient, rather than allowing a clump of adhesive material to become lodged or caught against a tooth or other structure as the distal end of tip 30 is moved in and out of the mouth. The shoulder 35 of the notched portion also forms a convenient surface for placing adhesive 38 on during the manufacturing process.

The notched distal end can have a variety of different configurations, such as the configuration shown in Figure 2 or the rounded configuration shown in Figure 2d, for example. Thus, in one embodiment, the delivery tip featured in Figure 2d has a shoulder 35 as shown in Figure 2 against which the coating 38c abuts (and may have flocking fibers 40c on both sides thereof, coupled through electrostatic flocking, for example, rather than only on one side thereof).

Thus, the elastomeric member of the present invention can be coupled to the distal delivery end of the main body in the form of a hollow tip member (e.g., Fig. 1A) or a coating (e.g., Fig. 2), for example. In addition, the fibers of the present invention may be mounted perpendicular to the elastomeric portion and/or may extend in a parallel relationship therewith, or in a variety of other configurations.

Figures 2A and 2B feature alternative distal delivery ends from that of Figure 2, with the remainder of body 31 being the same as in Figure 2 in one embodiment. In the embodiment of Figure 2A, rigid distal end 36a of body 31 does not notch inwardly, but rather, has an exterior surface that is relatively flush with the remainder of tubular body 31. Elastomeric coating 38a extends about the rigid delivery end 36a of body 31 and has fibers 40a mounted thereon, such as through electrostatic flocking.

In yet another embodiment, as shown in Figure 2B, elastomeric coating 38b is mounted about the distal end 36b of body 31 and/or on the distal rim 39b of distal end 36b and has fibers 40b mounted thereon, such as through electrostatic flocking.

In yet another embodiment of the present invention (not shown), an elastomeric material is disposed on the internal diameter of the distal end of the delivery tip and has fibers coupled thereto, such as through electrostatic flocking. Such a tip can be comprised of metal or plastic, for example, while the elastomeric material comprises a thermoplastic elastomer, or polyurethane, also by way of example.

Another cushioned delivery tip of the present invention comprises an elastomeric member coupled to a tubular member of a delivery tip, and has fibers mounted on the elastomeric member, such as through electrostatic flocking.

The hollow tip member (e.g., member 17) and the coating (e.g., coatings 38, 38a, 38b, 38c), may be flocked in a variety of different manners. For example, as shown in Figure 1C, in one embodiment, a wall 25 of hollow tip member 17 comprises a base 24

and an adhesive layer 26, shown in phantom lines. Flocking fibers F^1 may be placed on adhesive coating 26 and adhered thereto, such as through electrostatic flocking. Thus, with reference to Figure 1C, in one embodiment, tip member 17 comprises a base 24 of elastomeric material having an adhesive coating 26 thereon for maintaining fibers
5 thereon.

However, fibers may be coupled to tip member 17 in a variety of different manners. Optionally, fibers F^2 are embedded into base 24 of elastomeric tip member 17 (with or without adhesive layer 26) to maintain the fibers therein. Base 24 may comprise an elastomeric material, an elastomeric adhesive material (e.g., polyurethane), a series of
10 elastomeric adhesive coating materials placed sequentially onto one another, a molded elastomeric member or a variety of different possible members that maintain the fibers therein. As yet another option, adhesive 26 is also an elastomeric material, possibly the same material used for base 24 (e.g., polyurethane). Thus, it is possible for base 24 and adhesive coating 26 to be the same material, such as polyurethane, for example, or
15 different materials. Optionally, fibers are coupled to base 24 with or without an adhesive layer 26 through insert or injection molding.

With continued reference to Fig. 1C, in one embodiment, the width W of wall 25 of elastomeric tip member 17 (with or without adhesive layer) is in the range of about 0.2 mm to about 4 mm, more preferably about 0.3 mm to about 2.5 mm, most preferably
20 about 0.4 mm to about 1.8 mm. Also with reference to Fig. 1C, in another embodiment, the width W is greater than about 1 mm, such as in the range of: (i) greater than about 1 mm; to (ii) about 4 mm. A variety of different widths may be employed, however, depending upon a desired application.

The tip coatings (e.g., coatings 38, 38a, 38b, 38c) of the present invention may
25 also be flocked in a variety of different manners. For example, in one embodiment, elastomeric coating 38b comprises a base 42 and an adhesive coating 44, shown in phantom lines in Figure 2c. In this embodiment, base 42 can be formed by coupling base 42 to a rigid body 36b, such as through molding or adhesion, after which adhesive coating 44 is placed on base 42. Next, flocking fibers F^5 are placed on adhesive coating 44 and
30 adhered thereto, such as through electrostatic flocking.

Thus, with reference to Figure 2C, in one embodiment, coating 38b comprises a base 42 of elastomeric material having an adhesive coating 44 thereon for maintaining fibers thereon.

However, fibers may be coupled to end 36b in a variety of different manners. Optionally, fibers F³, F⁴ are embedded into base 36b (with or without adhesive layer 44) to maintain the fibers therein. Base 42 may comprise an elastomeric material, an elastomeric adhesive material, a series of elastomeric adhesive coating materials placed sequentially onto one another, a molded elastomeric member or a variety of different possible members that maintain the fibers therein. As yet another option, adhesive 44 is also an elastomeric material, possibly the same material used for base 42. Thus, it is possible for base 42 and adhesive coating 44 to be the same material (e.g., polyurethane) or different materials, for example. Optionally, fibers are coupled to base 42 with or without an adhesive layer through insert or injection molding.

In one embodiment, the width W of the elastomeric coating 38b (with or without adhesive layer) is in the range of about 0.1 mm to about 2 mm, more preferably about 0.2 mm to about 1 mm, most preferably about 0.25 mm to about 0.8 mm. In yet another embodiment, the width W is in the range of greater than about 0.5 mm, such as in the range of: (i) greater than about 0.5 mm; to (ii) about 2 mm. Coatings 38a, 38c may have the same dimensions as those described with respect to coating 38b, for example, although a wide variety of ranges are available.

Another embodiment of the present invention is shown in Figure 3A, which features an applicator 50 of the present invention. Applicator 50 has: (i) an elongate main body 52; and (ii) first and second applicator tips 54a and 54b mounted on body 52. Tips 54a and 54b are shown in Figures 3B and 3C, respectively. Each tip 54a, 54b comprises an elongate main body portion 56a and 56b having a respective proximal end 64a, 64b and a respective distal delivery end 58a and 58b. Each delivery end 58a, 58b has an elastomeric member 60a and 60b, respectively, coupled thereto. A plurality of fibers 62a and 62b, respectively, are coupled to the elastomeric member, such as through electrostatic flocking or through a variety of other methods.

It will be appreciated that an applicator of the present invention may comprise first and second tips which are configured as shown in Figures 3B or 3C, or a variety of

other configurations. For example, a tip may be configured as shown in Figure 3D, which features a paddle shaped tip 63 and may have an elastomeric material and flocking fibers thereon. It is possible to couple the elastomeric member of the present invention to the rigid material in a variety of different manners, such as by mounting the elastomeric member 60a on the end of the distal delivery end 58a, as shown in Figures 3B, or by forming a cap of elastomeric material 60b, as shown in Figure 3C. This may be accomplished through a variety of different methods, such as two-color molding, three color molding, adhesion, ultrasonic bonding or a variety of other methods known in the art.

10 Fibers 62A and/or 62B can have a variety of different lengths. In one embodiment, short and long fibers exist in a particular bundle of fibers such that the long fibers are supported by the short fibers.

 As shown in the phantom lines of Figures 3A and 3B, in one embodiment, tip 54a may be bent, such that the tip may be manipulated into a desired location. This may be accomplished, for example, by employing a grooved portion at proximal end 64a that is substantially thinner than the remainder of the tip body 56a, such that the tip can be bent into a desired location. The thinner grooved portion allows the distal delivery end of the tip to be selectively bent with respect to the more proximal gripping end. The applicator body may optionally be hollow in order to allow the distal end to bend more readily and to conserve material.

 The elastomeric members of the applicators disclosed herein act as cushioning members, and are substantially more deformable than the material of which the body of the applicator is comprised. For example, in one embodiment, the applicator body (and tip bodies 56a, 56b, for example) comprises a rigid polypropylene or polyethylene, while the elastomeric cushioning member comprises a deformable elastomeric material, such as a thermoplastic elastomer, rubber, polyurethane, another elastomeric adhesive material, or another material that is thick enough to have a cushioning effect.

 It will be appreciated in light of the disclosure herein that each tip 54a, 54b can itself be used independently as an applicator comprising a main body 56a, 56b having a proximal gripping end 64a, 64b and a distal delivery end 58a, 58b. Thus, each such tip 54a, 54b can also be considered to be an applicator as defined and claimed herein.

Yet another embodiment of an applicator 70 of the present invention is shown in Figures 4A and 4B. Applicator 70 has an elongate, rigid main body 75 having a proximal gripping end 72 and a distal end 73. An elastomeric member 79 is coupled to the distal end 73. The elastomeric member 79 includes a spherically shaped elastomeric member 74 coupled to an elongate elastomeric member 77 to form an elastomeric tip member 79. The length of member 77 may vary depending upon a desired application. In another embodiment, rather than employing elastomeric member 77, rigid body 75 extends to spherically shaped elastomeric member 74 and is coupled thereto. Elongate body 75 has an annular groove 78 therein that allows a distal portion of the body to be bent with respect to a proximal portion thereof. Body 75 can be hollow or solid.

Elastomeric tip member 79 enables a practitioner to readily deliver a desired material to difficult to reach places, crevices, cracks and spaces between teeth, in light of the deformable nature thereof. Member 79 conforms to a delivery location even if the location is rough and cracked. Such delivery can be performed without injuring the patient. In the embodiment of Figure 4A, the spherical portion 74 of tip member 79 is covered with a fibrous covering 76 comprising a series of fibers 76. However, fibers 76 are optional, as shown in Figure 4B, which demonstrates a front-end view of applicator 70 without fibers. Such a nonfibrous applicator 70 can be used to deliver materials to a desired location without injury and while conforming to a desired delivery location.

Nevertheless, fibers 76 are highly useful in that they can be used for massaging, manipulating, removing bubbles, cleaning, or for a variety of other purposes. Fibers 76 can be attached to tip member 79 through flocking, such as electrostatic flocking, for example, and may comprise both long and short fibers such that the short fibers support the longer fibers.

Tip member 79 can be flocked in a variety of different manners. For example, in one embodiment, spherical portion 74 comprises a base 80 (Fig. 4c) and an adhesive layer 82, shown in phantom lines. In this embodiment, base 80 can be formed by coupling base 80 to a rigid body or an elastomeric member 77 such as through molding or adhesion, after which adhesive coating 82 (Fig. 4C) is placed on base 80. Optionally, base 80 is integral with member 77, which is coupled to rigid body 75, such as through molding or adhesion. Following the placement of coating 82 on base 80, flocking fibers

F¹ are placed on adhesive coating 82 and adhered thereto, such as through electrostatic flocking. Thus, with reference to Figure 4C, in one embodiment, spherical portion 74 comprises a base 80 of elastomeric material having an adhesive coating 82 thereon for maintaining fibers thereon.

5 However, fibers may be coupled to tip member 79 in a variety of different manners. Optionally, fibers F² are embedded into base 80 of elastomeric tip member 79 (with or without adhesive layer 82) to maintain the fibers therein. Base 80 may comprise an elastomeric material, an elastomeric adhesive material (e.g., polyurethane), a series of elastomeric adhesive coating materials placed sequentially onto one another, a molded
10 elastomeric member or a variety of different possible members that maintain the fibers therein. As yet another option, adhesive 82 is also an elastomeric material, possibly the same material used for base 80. Thus, it is possible for base 80 and adhesive coating 82 to be the same material, such as polyurethane, or different materials, for example. Optionally, fibers are coupled to base 80 with or without an adhesive layer through insert
15 or injection molding.

 With continued reference to Fig. 4C, in one embodiment, the diameter D of the spherical portion 74 of the elastomeric tip member 79 (with or without adhesive layer 82) is in the range of about 0.2 mm to about 4 mm, more preferably about 0.3 mm to about 2.5 mm, most preferably about 0.4 mm to about 1.8 mm. Also with reference to Fig. 4C,
20 in another embodiment, the diameter D is greater than about 1 mm, such as in the range of: (i) greater than about 1 mm; to (ii) about 4 mm.

 Figure 5A demonstrates another embodiment of an applicator 70a comprising an elastomeric member in the form of a coating 74a deposited on a spherically shaped rigid distal delivery end 73a of a rigid body portion 72a, which is shown in a cutaway view.
25 The elastomeric coating 74a cushions the contact of the instrument 70a against the teeth and gums of a patient. Fibers 76a can include short and long fibers such that the long fibers are supported by the short fibers, for example.

 Elastomeric coating 74a can be flocked in a variety of different manners. For example, in one embodiment, elastomeric coating 74a comprises a base 80a (Fig. 5B) and
30 an adhesive coating 82a, shown in phantom lines. In this embodiment, base 80a can be formed by coupling base 80a to a rigid body 73, such as through molding or adhesion,

after which adhesive coating 82a (Fig. 5B) is placed on base 80a. Next, flocking fibers F^5 are placed on adhesive coating 82a, and adhered thereto, such as through electrostatic flocking. Thus, with reference to Figures 5A-5B, in one embodiment, coating 74a comprises a base 80a of elastomeric material having an adhesive coating 82a thereon for
5 maintaining fibers thereon.

However, fibers 76a may be coupled to end 73a in a variety of different manners. Optionally, fibers F^3 , F^4 are embedded into base 80a (with or without adhesive layer 82a) to maintain the fibers therein. Base 80 may comprise an elastomeric material, an elastomeric adhesive material, a series of elastomeric adhesive coating materials placed
10 sequentially onto one another, a molded elastomeric member or a variety of different possible members that maintain the fibers therein. As yet another option, adhesive 82a is also an elastomeric material, possibly the same material used for base 80a. Thus, it is possible for base 80a and adhesive coating 82a to be the same material, such as polyurethane, or different materials, for example. Optionally, fibers are coupled to base
15 80 with or without an adhesive layer through insert or injection molding.

In one embodiment, the width W of the elastomeric coating 74a (with or without adhesive layer 82a) is in the range of about 0.1 mm to about 2 mm, more preferably about 0.2 mm to about 1 mm, most preferably about 0.25 mm to about 0.8 mm. In yet another embodiment, the width W is in the range of greater than about 0.5 mm, such as in the
20 range of: (i) greater than about 0.5 mm; to (ii) about 2 mm.

In yet another embodiment of the present invention, the dental tool of the present invention comprises an elongate rigid body coupled to a flocked elastomeric member (such as a spherical elastomer as in Fig. 4c, 6a, or 31 or an elastomer having other shapes described herein), the elastomeric member having a diameter D in the range of about
25 4mm to about 40mm. This tool may act as a brush, for example. Optionally, the brush is configured as shown in Figure 5A and the elastomeric coating thereof has a width in the range of about 2mm to about 20mm.

Thus, in one embodiment of an instrument of the present invention, comprising a rigid body and a flocked elastomeric member, the elastomeric member has a diameter D
30 in the range of about 0.2 mm to about 40mm depending upon the embodiment.

Optionally, the tool is configured as shown in Figure 5A and the elastomeric coating thereof has a width in the range of about 0.1mm to about 20mm.

With reference now to Figures 6A-6B, another applicator 90 comprises an elongate body 92 and an elastomeric member in the form of a spherically shaped or paddle-shaped tip member 94 coupled to a distal end 95 of elongate body 92. Elastomeric member 94 optionally has fibers 96 coupled thereto, such as through electrostatic flocking. Elastomeric member 94 is shown without such flocking and having a paddle shape in a front view in Figure 6B. Flocking 96 may be applied through a variety of different methods, such as electrostatic flocking or other methods known in the art. Elastomeric member 94, whether in a paddle or spherical shape can have the same or similar dimensions as discussed above with respect to member 74, for example.

A paddle shaped for tip member 94, as shown in Figure 6B is highly useful in that it can be used as a scoop, a flattener or for a variety of different purposes. The entire paddle 94 may comprise an elastomeric portion.

In another embodiment of an applicator, however, as shown in Figures 7A-7B, an elastomeric member in the form of an elastomeric coating 94a covers the paddle-shaped distal delivery end 95a of a rigid elongate body member 92a. Fibers 96a can include short and long fibers such that the long fibers are supported by the short fibers. Coating 94a can have the same or similar dimensions as discussed above with respect to coating 74a, for example.

It will thus be appreciated from the present invention that the elastomeric member of the dental instrument of the present invention may have a variety of different shapes and configurations, such as: (i) a hollow elastomeric tip member 17, as shown in Figures 1A - 1B, (ii) a coating as shown in Figures 2, 5A, and 7A (iii) a solid tip member as shown in Figures 3A-3C, 4A, and 6A and a variety of other configurations. Each of these elastomeric members may be coupled to a corresponding rigid member through a variety of methods, such as two-color molding, three color molding, adhesion, ultrasonic bonding, insert or injection molding, or a variety of other methods known in the art.

The following discussion with regard to materials to be used and coupling methods can apply both to applicators and delivery tips. As mentioned above, in one embodiment, the body of a delivery tip or applicator comprises a rigid polypropylene or

polyethylene, while the elastomeric cushioning member coupled thereto comprises a deformable elastomeric material, such as a thermoplastic elastomer, rubber, polyurethane, another elastomeric adhesive material, or another material that is thick enough to have a cushioning effect.

5 Coupling of the elastomeric member, and optionally a nonslip cushioned grip as discussed with reference to Figures 19-31, to the rigid body of the delivery tip or applicator may be accomplished through a variety of different methods, such as two-color or three, four, five, or six color molding, insert or injection molding, other molding processes, adhesion, ultrasonic bonding (e.g., thermoplastic elastomer to polypropylene),
10 or a variety of other methods known in the art. Additional additives can be employed in the molding process to improve adhesion. Coupling can be enhanced through a mechanical bond such as by shaping the rigid plastic with a notch, such as an undercut or groove to receive a portion of the elastomeric member to assist in mechanically bonding a portion of the elastomeric member to the rigid body.

15 Also as previously mentioned, in one embodiment, the elastomeric member comprises an elastomeric adhesive, such as polyurethane. In this embodiment, the adhesive member placed on a rigid delivery tip body or rigid applicator body can itself be electrostatically flocked to form a cushioned, electrostatically flocked delivery tip. The elastomeric adhesive is employed in thicknesses sufficient to provide an elastomeric,
20 cushioned effect. Optionally, the elastomeric member may comprise a combination of an adhesive and another elastomeric material coupled to the adhesive.

 As yet another option, in one embodiment, the elastomeric member comprises a series of layers that are built up upon each other to form the elastomeric layer. For example, in one embodiment, a first layer is placed on the applicator body or delivery tip
25 body, after which the layer is cured. Next, a second layer is placed on the first layer and cured. Additional layers can be added as desired. Optionally, a single elastomeric layer is employed.

 The durometer of the thermoplastic elastomer or other elastomeric member coupled to the applicator or delivery tip may vary with the viscosity of the material to be
30 delivered. For example, when a higher viscosity impression material is to be delivered, it may be desirable to employ a higher durometer thermoplastic elastomer to more

effectively manipulate the more viscous impression material. On the other hand, when delivering a lower viscosity material, such as an etching material, it may be desirable to employ a lower durometer elastomeric member in order to provide more cushioning.

It is possible to practice the present invention without the use of flocking fibers, i.e., through the use of a delivery tip or applicator having the described elastomeric portions without the use of flocking fibers thereon. Nevertheless, the fibers can be employed on the delivery tips and/or applicators to remove particles from the mouth of a patient, to remove bubbles from an impression material or other material, to manipulate or massage appliances, teeth, gums or portions of the mouth, or for a variety of other purposes.

The stimulation provided by the fibers also results in better adaptation of the applied material around tooth surfaces. The fibers may also be used in a brushing or scrubbing action, which is advantageous for working other dental compositions into the tissues. The fibers can also be used for cleaning. If the elastomeric member, with the fibers mounted thereon, contacts the tooth or gums of a patient during delivery of material or during removal of air bubbles or other procedure, such contact will not harm or injure the patient.

Fibers can be disposed in spaced apart clumps around the elastomeric portion or surround the entire elastomeric portion. In each of the embodiments disclosed herein employing fibers, the fibers can include short and long fibers such that the long fibers are supported by the short fibers.

The fibers may be coupled to the elastomeric member in a variety of different manners, such as through flocking, e.g., electrostatic flocking, gravity flocking, and a variety of other flocking methods. Such flocking may occur through a variety of different procedures.

According to one flocking method, an adhesive material is applied where fiber attachment is desired. An appropriate quantity of fibers is then contacted with the adhesive material. The adhesive is allowed to harden, thereby securing the fibers to the desired portion. The adhesive can be an adhesive coating and/or a portion of an adhesive base material.

An additional method of fiber attachment is to injection or insertion mold the fibers onto the desired elastomeric member. Thus, the fibers and elastomeric member can each be injection or insertion molded, either by (i) initially injection or insertion molding the elastomeric member onto the rigid applicator or delivery tip body, followed by
5 insertion or injection molding of the fibers onto the elastomeric member; or (ii) simultaneously injection or insertion molding the elastomeric member onto the rigid body and the fibers onto the elastomeric member, for example. Such molding can occur with a plastic material (possibly the same or different materials). Thus, in one embodiment, the fibers are in a diameter and length which allows injection or insertion molding.

10 Both natural and synthetic fibers may be used. Suitable natural fibers include cotton fibers, while suitable synthetic fibers include nylon and polyester fibers. In addition, as mentioned, various injection moldable plastics can be employed to form the fibers of the present invention using standard injection molding techniques.

In one embodiment, the rigid main body portion of a particular delivery tip or
15 applicator comprises a rigid material such as polypropylene or polyethylene, the elastomeric member comprises a deformable material and the fibers mounted on the elastomeric member comprise: (i) a deformable material; or (ii) a rigid material. The elastomeric member is more deformable than the rigid main body and the fibers can be more rigid, less rigid, or have the same rigidity as the material employed for the main
20 body of the delivery tip or applicator. This can be achieved, for example, through three color molding or through insert or injection molding. Four or five color molding can be used if a non-slip grip is employed, for example.

For example, in one embodiment, the rigid main body portion of a particular
25 delivery tip or applicator comprises a rigid material such as polypropylene or polyethylene, the elastomeric cushioning member comprises an elastomeric thermoplastic elastomer that is softer than the applicator body or delivery tip body and the fibers comprise a thermoplastic elastomer having a higher durometer than the delivery tip body or applicator body. Optionally, the fibers comprise a polypropylene, polyethylene or another material having a hardness comparable to polypropylene or polyethylene.

30 In another embodiment of the present invention, the fibers comprise a material that is less rigid than the elastomeric cushioning material of a particular delivery tip or

applicator. In yet another embodiment, the fibers comprise a material that has the same rigidity as the elastomeric cushioning material. For example, in this embodiment, the fibers and cushioning material are formed from the same material.

Also by way of example, in one embodiment, the rigid body portion of a particular delivery tip or applicator comprises polypropylene or polyethylene, the
5 elastomeric member comprises a softer thermoplastic elastomer, rubber, polyurethane, or other deformable material and the fibers mounted on the elastomeric member comprise an injection or insertion molded thermoplastic elastomer. Such an injection molded thermoplastic elastomer may have a higher durometer than the elastomeric member.
10 Optionally, the fibers comprise polypropylene, polyethylene or another material having a hardness comparable to polypropylene or polyethylene. This may be achieved through two or three color molding, insert or injection molding, for example.

The dental tool of the invention can be made with thinner fibers or with thicker fibers. For example, the tool made with thinner fibers may be useful in delivering
15 compositions such as sealing agents that need to be "spread" or "painted" onto tooth surfaces. The delivery tip made with thicker fibers can be useful in delivering and agitating higher viscosity materials, such as impression materials and other appropriate materials, for example.

In one embodiment, the length of the fibers of the delivery tips disclosed herein
20 is in the range from about 0.3 mm to about 5 mm, preferably about 0.3 mm to about 3 mm, and more preferably from about 0.5 mm to about 2 mm. In this embodiment, the diameter of the fibers of the delivery tips may be in the range from about 1 Denier to about 15 Denier, and more preferably in the range from about 1.5 Denier to about 10 Denier, for example. This embodiment may be useful for delivering sealing agents, for
25 example.

In yet another embodiment, such as when higher viscosity materials (e.g., impression materials) are employed, the length of the fibers may be in the range from about 0.3 mm to about 5 mm, preferably about 1 mm to about 3 mm, and more preferably from about 1.5 mm to about 2 mm. The diameter of such fibers may be in the range from
30 about 3 Denier to about 75 Denier, about 3 Denier to about 45 Denier, and more

preferably in the range from about 6 Denier to about 20 Denier, for example. This embodiment may be useful for removing bubbles in impression material, for example.

Also by way of example, the fiber length for the fibers of the applicators disclosed herein may be in the range from about 0.3 mm to about 3 mm, preferably from
5 about 0.5 mm to about 2 mm, more preferably from about 0.7 mm to about 1.5 mm, such as about 1 mm, for example. In one embodiment, the fiber diameter of the applicators is in the range from about 1 Denier to about 45 Denier, preferably about 1.5 Denier to 20 Denier, and more preferably in the range from about 1.5 Denier to about 10 Denier.

However, these ranges are highly dependent upon viscosities of materials
10 employed, surface tensions, cohesiveness, and other physical properties. Brushes of the present invention may have a variety of different lengths of fibers, such as about 3 mm to about 20 mm in one embodiment, although other ranges are possible, including longer and shorter fibers. Such brushes may require larger diameter fibers than other instruments of the present invention, although the exact sizes depend upon a desired use.

15 In a preferred embodiment, the adhesive used to attach the fibers to the body or elastomeric portion of the tool is water insoluble. It is also important that the components of the dental tool will not react with a dental composition used therewith. In addition, the dental composition should not adhere to the construction materials used. Since many dental compositions are light sensitive, the construction materials used may be light-
20 resistive. For example, various colored plastics that tend to filter out light can be employed in making the dental tool.

The elastomeric members disclosed herein and coupled to the distal ends of the main bodies of the applicators and delivery tips disclosed are examples of means for cushioning the distal ends of the main bodies. The dental tools described can be formed
25 in a variety of different shapes and sizes and the sizes illustrated have been provided by illustration only.

Reference will now be made to Figures 8A and 8B. Figures 8A and 8B demonstrate alternative applicators 100, 100a of the present invention. Each applicator 100, 100a has a main body 101, 101a. The main body of each applicator comprises a
30 rigid proximal gripping end 102, 102a; a rigid distal delivery end 104, 104a and an elastomeric member 106, 106a that couples proximal gripping end 102, 102a to distal

delivery end 104, 104a. As shown, the elastomeric member 106, 106a may have a variety of different shapes. The applicator may have a rigid distal delivery tip member 108 or may have an elastomeric tip member 108a coupled to the distal delivery end 104, 104a. The rigid distal delivery tip member 108 or elastomeric tip member 108a can have fibers
5 109, 109a flocked thereon, such as through electrostatic flocking, or may have the fibers coupled thereto through another method. Thus, the distal delivery end may have fibers directly coupled thereto, or indirectly coupled thereto (e.g., by having the fibers coupled to an elastomeric member).

It may be advantageous for an applicator to have an elastomeric material dividing
10 a first rigid member from a second rigid member, as shown in Figures 8A and 8B. For example, certain materials require the use of a rigid distal delivery end for delivery thereof. In addition, certain chemicals to be delivered are most compatible with certain rigid materials, such as polypropylene. Nevertheless, it may be desirable to enable the tool to still flex in certain areas. The elastomeric transition section can enable a
15 practitioner to achieve each of these goals and reach a desired location within a patient's mouth, for example, which requires flexibility.

Optionally, it may be desirable to employ an applicator having a proximal rigid body, an elastomeric transition section, and a distal section coupled to the elastomeric transition section that is also elastomeric, but is more rigid than the transition section.
20 Such an embodiment is also possible according to the present invention.

With reference now to Figures 9A and 9B, another embodiment of a dental applicator 200 comprises a hollow rigid main body 202 and an elastomeric member 204 coupled to the hollow main body 202. Elastomeric member 204 has fibers 206 thereon. Fibers 206 are deposited, for example, through electrostatic flocking. Elastomeric
25 member 204 has a hollow channel 208 extending therethrough. Channel 208 is in fluid communication with a channel 216 in hollow main body 202. Channels 208, 216 enable fluid to flow through body 202 and elastomeric member 204. Channel 208 is an example of means for enabling fluid to flow through elastomeric member 204. Another example of means for enabling fluid to flow through elastomeric member comprises elastomeric
30 member 204 being configured from a permeable material, through which a fluid may flow. One advantage of such a hollow main body 202 of applicator 200 is that hollow

main body 202 may be movably coupled in fluid communication with a reservoir, such as reservoir 210. Reservoir 210, main body 202 and elastomeric member 204 collectively form a delivery system. As one option, the delivery system conveniently acts as a "unit dose applicator 200" that can be conveniently used to deliver a predetermined dosage of material, for example, to the mouth of a patient, then manipulate the material with fibers 206 and cushioning material 204. Optionally, the delivery system can be resealable for a number of different applications.

As shown, reservoir 210 comprises an elongate member having a cavity 212 in which fluid 214 is selectively placed. Cavity 212 is in fluid communication with hollow chamber 216 in main body 202. For example, cavity 212 may communicate with hollow chamber 216 in main body 202 through port 218 in main body 202, which is in fluid communication with hollow chamber 216.

A circular flange 220 coupled to main body 202 slides back and forth within cavity 212 and abuts shoulders 222 of reservoir 210 when main body 202 is moved to an extended position, as shown in Figure 9A. An O-ring 224 prevents fluid from leaking from reservoir 210. When main body 202 is moved to a contracted position, as shown in Figure 9B, fluid 214 compressed within reservoir 210 is expelled through channel 216 and out of elastomeric member 204 onto the surface of the elastomeric member, fibers 206 and optionally into the mouth of a patient or other object. Thus, movement of the hollow main body with respect to the reservoir selectively causes fluid within the main body to flow from the elastomeric member. This fluid can then be delivered to a desired location.

A lid 226 is selectively mounted on elastomeric member 204 and its associated fibers 206 to prevent fluid from inadvertently leaking from applicator 200. Lid 226 is an example of means for selectively sealing applicator 200.

With reference to Figures 10A and 10B, as another example of such means for selectively sealing an applicator, main body 202a can be rotatably mounted on a base member 230a. Base member 230a is disposed within a reservoir 212a and has a port 232a therein that selectively communicates with a proximal port 218a of main body 202a. As shown in Figure 10B, upon moving proximal port 218a, which is in fluid communication with chamber 216a, in fluid communication with port 232a (i.e. by

rotating main body 202a with respect to base member 230a) fluid can flow from cavity 212a through chamber 216a and out of elastomeric member 204a, which can be a perforated member, for example. Upon aligning ports 232a and 218a and upon compressing reservoir 212a and main body 202a, as shown in Figure 90b, fluid flows in the direction of arrows 234a through port 232a, port 218a, channel 216a and out of member 204. O-rings 224a, 225a assist in sealing fluid within reservoir 212a until it is expelled through chamber 216a.

Figures 11A-18B disclose a variety of different tip members for applicators of the present invention. The elastomeric tip members are designed to be coupled to the distal end of a rigid elongate body, such as body 92. In one preferred embodiment, the tip members of Figures 11A-11B have fibers coupled thereto (see Fig. 11B) such as through electrostatic flocking or a variety of other manners. The groove(s) of the distal tips of Figures 11A-17B allow the tip members to compress as the tips are forced in between or against teeth. This both cushions the movement of a dental tool against the teeth and allows the tips to fit between teeth and into other difficult to reach places in the mouth of a patient.

The elastomeric tip members of Figures 11A-17B each feature an elastomeric spherical member having at least one groove therein. For example, distal tip member 110 of Figures 11A-11C features an elastomeric spherical member 112 and having a V-shaped groove 116 therein. In the embodiment shown, member 110 is coupled to a rigid body 114 (shown in a cutaway view). In light of groove 116, spherical member 112 is more likely to flex as spherical member 112 is moved against or between teeth. Figure 11B shows an example of a fiber-covered tip member 110, which may be flocked via electrostatic flocking, for example. Such fiber covering may be employed on the other tips disclosed in Figures 11A-18B.

Distal tip member 120 of Figures 12A-12B features an elastomeric spherical member 122 having a star-shaped groove 126 therein. In the embodiment shown, member 120 is coupled to a rigid body 124 (shown in a cutaway view). In light of groove 126, spherical member 122 is more likely to flex as spherical member 122 is moved against or between teeth. The star shape allows five different portions of the tip 120 to move inwardly with respect to each other, providing flexibility in a variety of different

directions. Distal tip member 130 of Figures 13A-13B features an elastomeric spherical member 132 having a slot-shaped groove 136 therein. In the embodiment shown, member 130 is coupled to a rigid body 134 (shown in a cutaway view). In light of groove 136, spherical member 132 is more likely to flex as spherical member 132 is moved against or between teeth. The groove allows the different sides of the tip 130 to flex with respect to each other.

Distal tip member 140 of Figures 14A-14B features an elastomeric spherical member 142 having a V-shaped groove 146 therein. In the embodiment shown, member 140 is coupled to a rigid body 144 (shown in a cutaway view). In light of groove 146, spherical member 142 is more likely to flex as spherical member 142 is moved against or between teeth. The V-shaped groove allows a wide gap such that the sides of the tip can flex significantly with respect to each other.

Distal tip member 150 of Figures 15A-15B features an elastomeric spherical member 152 having a plurality of V-shaped grooves 156a, 156b, 156c therein. In the embodiment shown, member 150 is coupled to a rigid body 154 (shown in a cutaway view). In light of grooves 156a-c, spherical member 152 is more likely to flex as spherical member 152 is moved against or between teeth. In light of the plurality of V-shaped grooves, spherical member 152 flexes significantly when moved between teeth.

Distal tip member 160 of Figures 16A-16B features an elastomeric spherical member 162 having a modified V-shaped groove 166 therein. In the embodiment shown, member 160 is coupled to a rigid body 164 (shown in a cutaway view). In light of groove 166, spherical member 162 is more likely to flex as spherical member 162 is moved against or between teeth.

Figures 17-18 disclose different paddle tip members of the present invention. Distal tip member 170 of Figures 17A-17B features an elastomeric paddle shaped member 172 having a V-shaped groove therein. Member 170 is coupled to body 174. In light of the V-shaped groove, paddle shaped member 172 is more likely to flex as the paddle-shaped member 172 is moved against or between teeth.

Figures 18A-18B also disclose a paddle tip member of the present invention. Distal tip 180 of Figures 18A-18B features an elastomeric paddle shaped member 182

coupled to a rigid body 184. This paddle shape provides convenient manipulation of material to be delivered to a desired location.

Figures 19-30 demonstrate examples of non-slip gripping surfaces that can be employed in the present invention to provide a non-slip grip along the rigid body of the applicators of the present invention, such as the applicators shown in Figures 3A-8B. Figure 31 demonstrates a perspective view of one example of the location of a non-slip material with respect to the remainder of the rigid body of the applicator 186 of Figure 19, although a variety of different applicator configurations are also possible. Applicator 186 of Figure 31 has an elastomeric, spherically shaped distal tip member 188, coupled to body 186.

The non-slip material employed in such non-slip grips can comprise the same elastomeric material as described as being coupled to the distal end of the elongate body. The non-slip portion may, for example, comprise a polyurethane, rubber, a thermoplastic elastomer, or another deformable material disclosed herein, such as any of those materials disclosed for use as an elastomeric member coupled to the distal end of an elongate body. Optionally, however, a different material is employed for the non-slip portion. As shown, the rigid body of the dental tool of the present invention may have a variety of different gripping surfaces.

Figure 19 demonstrates a grip portion of the body of a dental applicator. Grip 190 comprises: (i) a grip body 192; and (ii) a network of interlocking ridges 194 extending about body 192. Ridges 194 may comprise a material that is elastomeric, for example, while body 192 is rigid, thereby providing a nonslip gripping surface. Ridges 194 are an example of means for enhancing the gripping surface of grip 190.

Figure 20 demonstrates a grip portion of the body of a dental applicator. Grip 190a comprises: (i) a series of elastomeric grip body portions 192a; and (ii) a network of rigid interlocking grooves 194a dividing the grip body portions 192a. Grooves 194a and portions 192a are an example of means for enhancing the gripping surface of grip 190a.

Figure 21 demonstrates a grip portion of the rigid body of a dental applicator. Grip 190b comprises: (i) a grip body 192b; and (ii) a series of ridges 194b extending about body 192b. Ridges 194b may comprise a material that is elastomeric, for example,

while body 192b is rigid, thereby providing a nonslip gripping surface. Ridges 194b are an example of means for enhancing the gripping surface of grip 190b.

Figure 22 demonstrates a grip portion of the rigid body of a dental applicator. Grip 190c comprises: (i) a series of elastomeric grip body portions 192c; and (ii) a series of grooves 194c extending about body 192c. Grooves 194c and grip body portions 192c are an example of means for enhancing the gripping surface of grip 190c.

Figure 23 demonstrates a grip portion of the rigid body of a dental applicator. Grip 190d comprises: (i) a grip body 192d; and (ii) a series of longitudinal ridges 194d extending about body 192d. Ridges 194d may comprise a material that is elastomeric, for example, while body 192d is rigid, thereby providing a nonslip gripping surface. Ridges 194d are an example of means for enhancing the gripping surface of grip 190d.

Figure 24 demonstrates a grip portion of the rigid body of a dental applicator. Grip 190e comprises: (i) a series of elastomeric grip body portions 192e; and (ii) a series of rigid longitudinal grooves 194e extending adjacent body portions 192e. Grooves 194e and body portions 192e are an example of means for enhancing the gripping surface of grip 190e.

Figure 25 demonstrates a grip portion of the rigid body of a dental applicator. Grip 190f comprises: (i) a grip body 192f; and (ii) a series of knobs 194f extending about body 192f. Knobs 194f may comprise a material that is elastomeric, for example, while body 192f is rigid, thereby providing a nonslip gripping surface. Knobs 194f are an example of means for enhancing the gripping surface of grip 190f.

Figure 26 demonstrates a grip portion of the rigid body of a dental applicator. Grip 190g comprises: (i) an elastomeric grip body portion 192g; and (ii) a series of rigid grooves 194g in body portion 192g. Grooves 194g and body portion 192g are an example of means for enhancing the gripping surface of grip 190g.

Figure 27 demonstrates a grip portion of the rigid body of a dental applicator. Grip 190h comprises: (i) a grip body 192h; and (ii) a series of knobs 194h extending about body 192h. Knobs 194h may comprise a material that is rigid for example, while body 192h is elastomeric, thereby providing a nonslip gripping surface. Knobs 194h and body 192h are an example of means for enhancing the gripping surface of grip 190h.

Figure 28 demonstrates a grip portion of the rigid body of a dental applicator. Grip 190i comprises: (i) an elastomeric grip body portion 192i; and (ii) a series of elastomeric grooves 194i in body portion 192g. Grooves 194g and body portion 192g are an example of means for enhancing the gripping surface of grip 190g.

5 Figure 29 demonstrates a grip portion of the rigid body of a dental applicator. Grip 190j comprises: (i) a grip body 192j; and (ii) a winding ridge 194j extending about body 192j. Ridge 194j may comprise a material that is elastomeric, for example, while body 192j is rigid, thereby providing a nonslip gripping surface. Ridges 194j are an example of means for enhancing the gripping surface of grip 190j.

10 Figure 30 demonstrates a grip portion of the rigid body of a dental applicator. Grip 190k comprises: (i) a series of elastomeric grip body portions 192k; and (ii) a winding groove 194k extending about body 192k. Groove 194k and grip body portions 192k are an example of means for enhancing the gripping surface of grip 190k.

The dental instruments of the present invention may be used to apply various
15 dental materials into the mouth of a patient. One method for delivering a dental material within the mouth of a patient comprises: (1) providing a dental instrument, comprising: (A) a main body having a proximal end and a distal end; and (B) means for cushioning the distal end of the main body; (2) loading the dental instrument with a dental material; and (3) delivering the dental material within the mouth of the patient (possibly including,
20 for example, moving the distal delivery end of the dental instrument into the mouth of the patient and depressing a plunger or scraping material from the instrument against the teeth or gums). The dental instrument may comprise, for example, (i) a delivery system comprising a delivery tip and a delivery device coupled thereto; or (ii) an applicator.

For example, in one embodiment, the dental instrument comprises a delivery tip
25 having a syringe or another delivery device coupled thereto, the delivery tip having an elastomeric member on a distal end thereof. In such an embodiment, delivering the dental material within the mouth of a patient may comprise depressing a plunger movably coupled to a barrel of the syringe. Loading the dental instrument may comprise placing a dental material within a barrel of the syringe, for example.

30 In another embodiment, the instrument comprises a dental applicator and loading the instrument with a dental material comprises: (i) placing a dental material on the

applicator, e.g., specifically on the elastomeric cushioning member (such as by scooping a quantity of dental material onto a dental applicator); or (ii) loading a reservoir such as reservoir 210 or 210a with a dental material.

In one embodiment, the method of use further comprises positioning the dental instrument within the patient's mouth against air bubbles within the mouth of the patient, such as by positioning the fibers of the instrument against air bubbles within the mouth of the patient.

Thus, a method for furthering a dental procedure without causing pain to the teeth or gums of a patient, comprises: (1) providing (i) a rigid main body having a proximal end and a distal end, the rigid main body being configured to be grasped by a practitioner; and (ii) means for cushioning the distal end of the rigid main body; and (2) positioning at least a portion of the dental instrument within the patient's mouth. In one embodiment, the dental instrument comprises an instrument selected from the group consisting of: (i) an applicator; and (ii) a syringe. One embodiment of the method further comprises: (i) delivering a material into the mouth of the patient; and (ii) placing the instrument against the material delivered. Placing the delivery tip against the material delivered may comprise placing a portion of the instrument (e.g., the fibrous portion) against air bubbles within the material delivered in order to eliminate the air bubbles.

Thus, one embodiment of a method for positioning a dental instrument within the mouth of a patient so as to remove air bubbles from material delivered within the mouth of the patient is conducted without injuring or causing pain to the teeth or gums of the patient. Such a method, as described herein may comprise providing a dental applicator or delivery tip having a plurality of fibers at a distal end thereof as described herein and positioning the dental applicator within the patient's mouth against air bubbles within the mouth of the patient, such that the fibers contact and burst the air bubbles.

Figures 32-33 demonstrate an example of applicator 186 having fibers 240 coupled to elastomeric member 188 and having a dental material 242 placed thereon. Upon placing the cushioned, fiber-covered portion of applicator 186 into the mouth 244 of a patient, the material 242 can be delivered to a desired location. Figure 33 shows a mouth 244 in which the material 242 has been delivered against the teeth and gums of a patient. As depicted, the material 242 can be delivered to a desired location, after which

the fibers 240 can be moved against air bubbles 246 formed in the material to eliminate the air bubbles.

The fibers of the present invention may be coupled to the elastomeric material in a variety of different patterns. For example, the fibers may substantially surround a hollow elastomeric member 17 or a rigid tubular body 36 or may be placed thereon in discrete clumps, for example. Similarly, the fibers may substantially surround a tip, such as shown in Figures 11B and 32, or may only be mounted on one or more sides or surfaces thereof, depending upon a desired application.

According to the present invention, various dental instruments can be manufactured through the methods described above, including the use of flocking, such as electrostatic flocking, for example. Such instruments may comprise elastomeric portions to which fibers are flocked, for example.

Nevertheless, while the applicators and delivery tips described herein are particularly useful in the field of dentistry, it is also possible to use such applicators and delivery tips or similar applicators and tips in a variety of different fields, including the fields of painting, nail polish, make up, and other fields in which a liquid or pliable material is delivered to a surface and/or manipulated on a surface.

The present invention may be embodied in other specific forms without departing from its spirit or essential characteristics. The described embodiments are to be considered in all respects only as illustrative and not restrictive. The scope of the invention is, therefore, indicated by the appended claims rather than by the foregoing description. All changes, which come within the meaning and range of equivalency of the claims, are to be embraced within their scope.

What is claimed and desired to be secured is:

1. A cushioned delivery applicator, comprising:
a main body having a proximal end and a distal end,
means for cushioning the distal end of the main body such that abutment of the
5 dental instrument against the teeth or gums of a patient does not injure or cause pain to
the teeth or gums; and
a plurality of fibers coupled to the means for cushioning the distal end of the
main body.
2. An applicator as recited in claim 1, wherein the main body comprises an
10 elongate rigid main body configured to be selectively grasped by a practitioner;
3. An applicator as recited in claim 1, wherein the means for cushioning the
distal end of the rigid main body comprises an elastomeric member coupled to the distal
end of the main body.
4. An applicator as recited in claim 1, wherein the main body comprises a
15 rigid material, the means for cushioning comprises an elastomeric material, and the fibers
comprise a material that is more rigid than the elastomeric material.
5. An applicator as recited in claim 1, wherein the main body comprises a
rigid material, the means for cushioning comprises a deformable elastomeric material,
and the fibers comprise a material that is less rigid than the elastomeric material.
- 20 6. An applicator as recited in claim 1, wherein the main body comprises a
rigid material, the means for cushioning comprises an elastomeric deformable material,
and the fibers comprise a material that has the same rigidity as the elastomeric material.
7. An applicator as recited in claim 1, wherein the fibers are deposited onto
the means for cushioning through electrostatic flocking.
- 25 8. An applicator as recited in claim 1, wherein the main body comprises a
non-slip gripping surface.
9. An applicator as recited in claim 1, wherein the applicator is formed
through a process comprising a procedure selected from the group consisting of two color
molding, three color molding, injection molding and insertion molding.
- 30 10. An applicator as recited in claim 1, wherein the means for cushioning
comprises a spherical elastomeric material.

11. An applicator as recited in claim 10, wherein the spherical elastomeric material has a groove therein.
12. An applicator as recited in claim 1, wherein the applicator has a hollow main body in fluid communication with an opening in the means for cushioning.
- 5 13. An applicator as recited in claim 12, wherein the applicator further has a reservoir in fluid communication with the hollow main body.
14. An applicator as recited in claim 13, wherein movement of the hollow main body with respect to the reservoir selectively causes fluid within the main body to flow from the means for cushioning.
- 10 15. An applicator as recited in claim 1, wherein the main body comprises a first rigid member, a second rigid member and an elastomeric member connecting the first rigid member to the second rigid member, the means for cushioning coupled to the second rigid member.
16. An applicator as recited in claim 1, wherein the means for cushioning
15 comprises a coating.
17. An applicator as recited in claim 1, wherein the means for cushioning comprises a solid tip member.
18. An applicator as recited in claim 1, wherein the means for cushioning comprises an elastomeric adhesive.
- 20 19. An applicator as recited in claim 1, wherein the distal end of the main body comprises a paddle shaped member.
20. An applicator as recited in claim 1, wherein the distal end of the main body comprises a spherically shaped member.
21. An applicator as recited in claim 1, wherein the means for cushioning
25 comprises an elastomeric material having a diameter in the range of about 0.2 mm to about 40mm.
22. An applicator as recited in claim 1, wherein the means for cushioning comprises an elastomeric material having a diameter in the range of about 0.4 mm to about 1.8 mm.

23. An applicator as recited in claim 1, wherein the means for cushioning comprises an elastomeric material having a diameter in the range of: (i) greater than about 1 mm; to (ii) about 4 mm.
24. An applicator as recited in claim 1, wherein the applicator serves as a
5 cleaning device.
25. An applicator as recited in claim 1, wherein the applicator serves as a brush.
26. An applicator as recited in claim 1, wherein the elastomeric member comprises a base and an adhesive coating on the base.
- 10 27. An applicator as recited in claim 1, wherein the means for cushioning comprises an elastomeric coating having a width in the range of about 0.1mm to about 20mm.
28. An applicator configured to be positioned against the teeth and gums of a patient without injuring or causing pain to the teeth or gums, the applicator comprising:
15 a main body having a proximal gripping end and a distal delivery end,
an elastomeric member coupled to the distal delivery end of the main body such that abutment of the dental instrument against the teeth or gums of a patient does not injure or cause pain to the teeth or gums; and
a plurality of fibers coupled to the elastomeric member.
- 20 29. An applicator configured to be positioned against the teeth and gums of a patient without injuring or causing pain to the teeth or gums, the applicator comprising:
a rigid main body having a proximal gripping end and a distal delivery end,
a spherically shaped elastomeric tip coupled to the delivery end of the main body
such that abutment of the dental instrument against the teeth or gums of a patient does not
25 injure or cause pain to the teeth or gums; and
a plurality of electrostatically flocked fibers substantially surrounding the elastomeric tip.
30. An applicator configured to be positioned against the teeth and gums of a patient without injuring or causing pain to the teeth or gums, the applicator comprising:
30 a main body having a proximal gripping end and a distal delivery end,

an elastomeric member coupled between the proximal gripping end and the distal delivery end of the main body; and

a plurality of fibers coupled to the distal delivery end of the main body.

31. An applicator as recited in claim 30, wherein an elastomeric member is
5 coupled to the distal delivery end of the main body such that abutment of the dental instrument against the teeth or gums of a patient does not injure or cause pain to the teeth or gums.

32. An applicator as recited in claim 31, wherein the plurality of fibers are coupled to the elastomeric member, which is coupled to the distal delivery end.

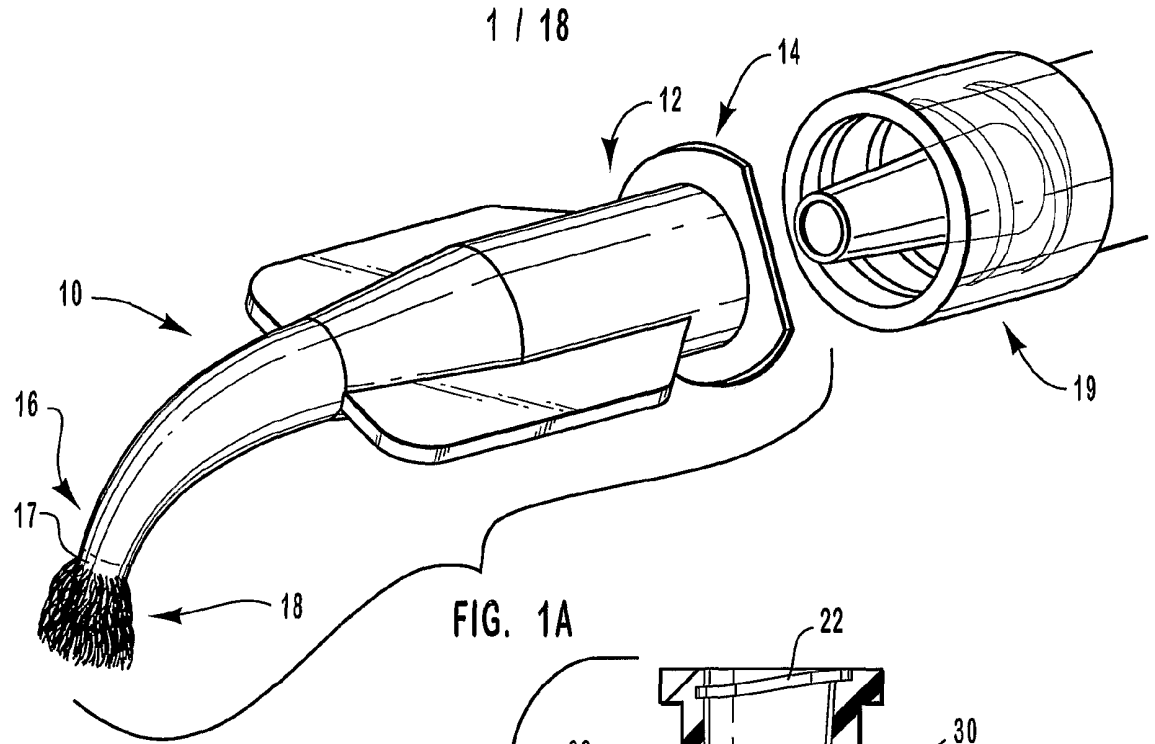

FIG. 1A

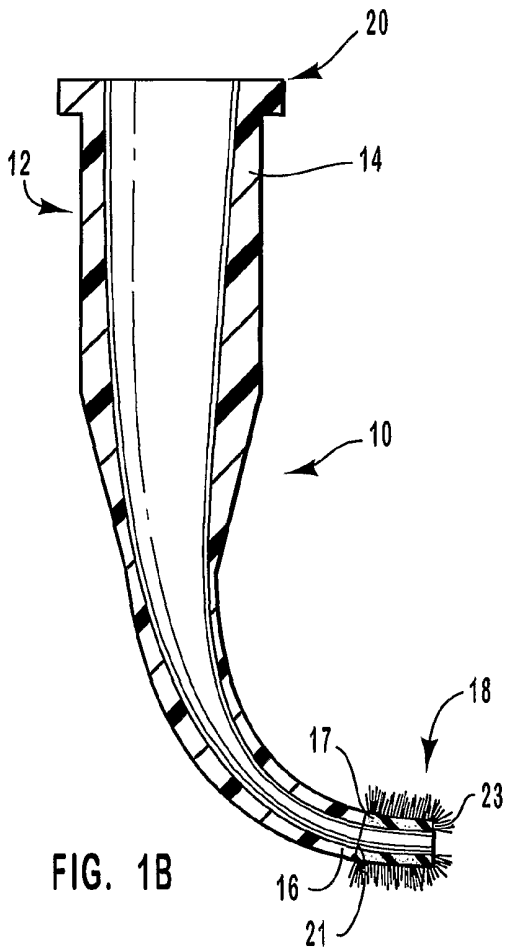

FIG. 1B

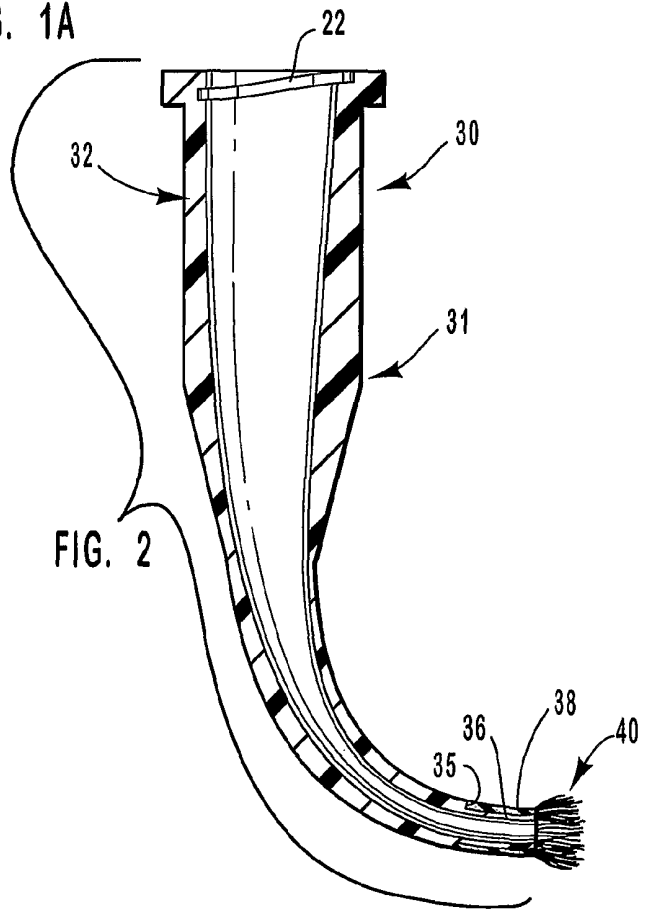

FIG. 2

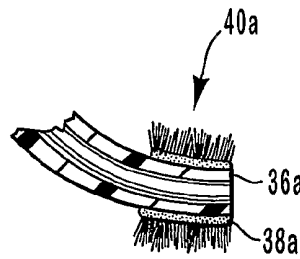

FIG. 2A

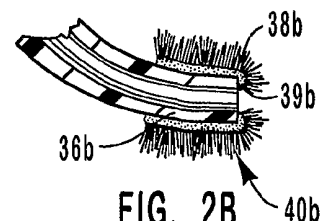

FIG. 2B

2 / 18

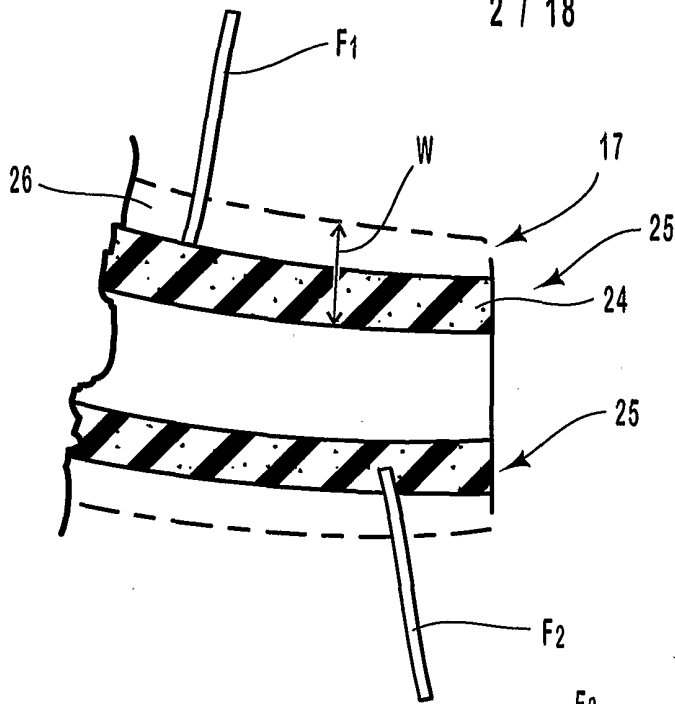

FIG. 1C

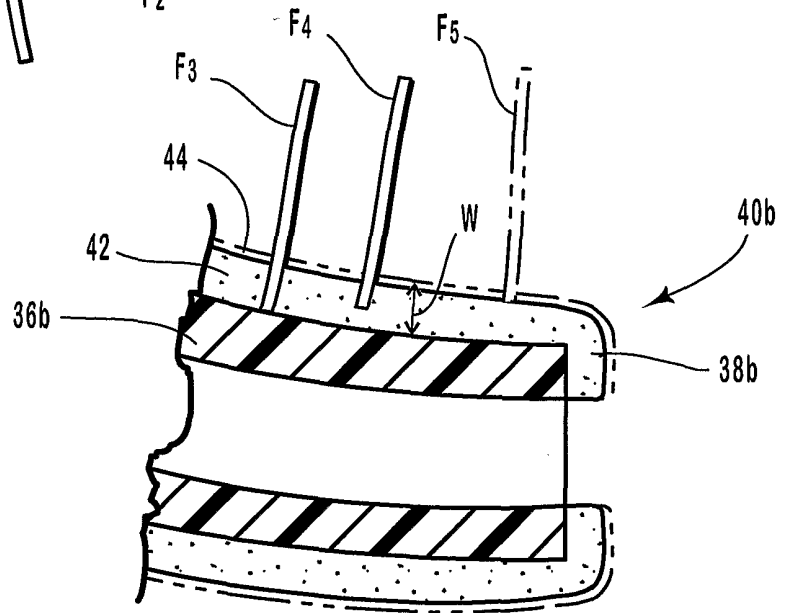

FIG. 2C

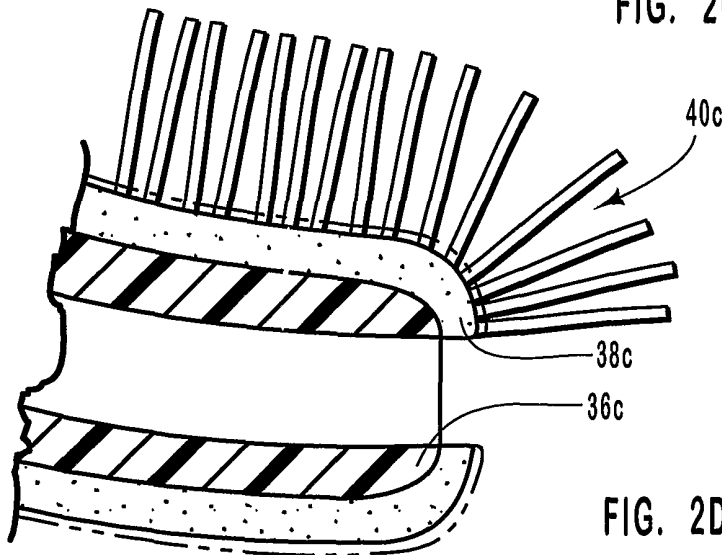
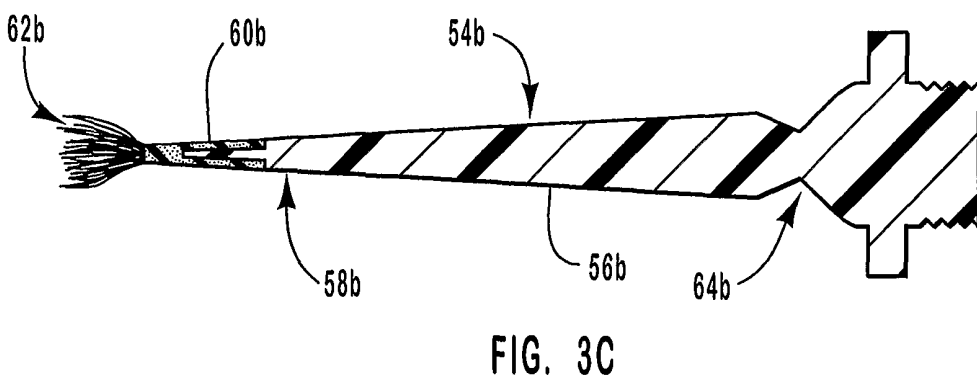
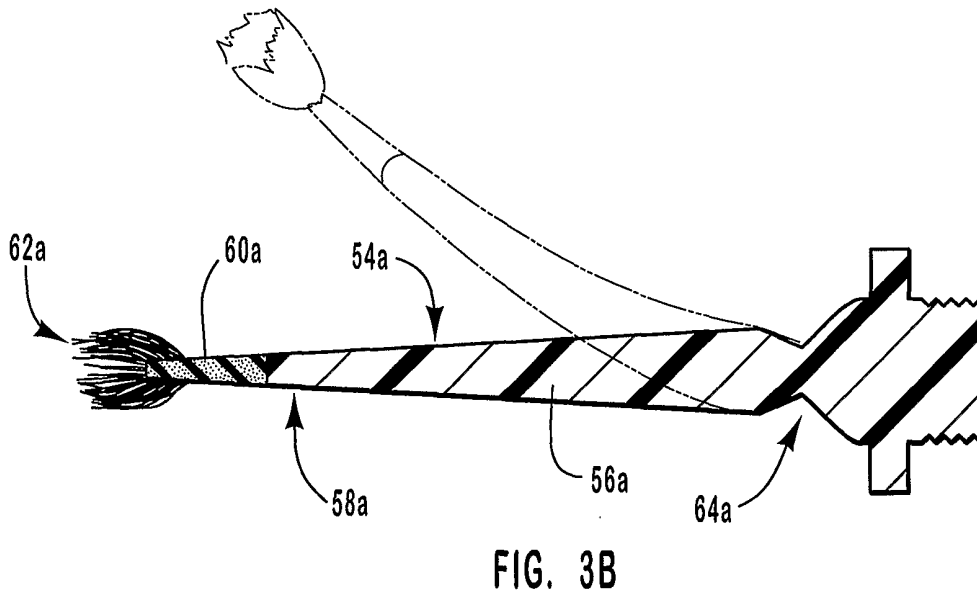
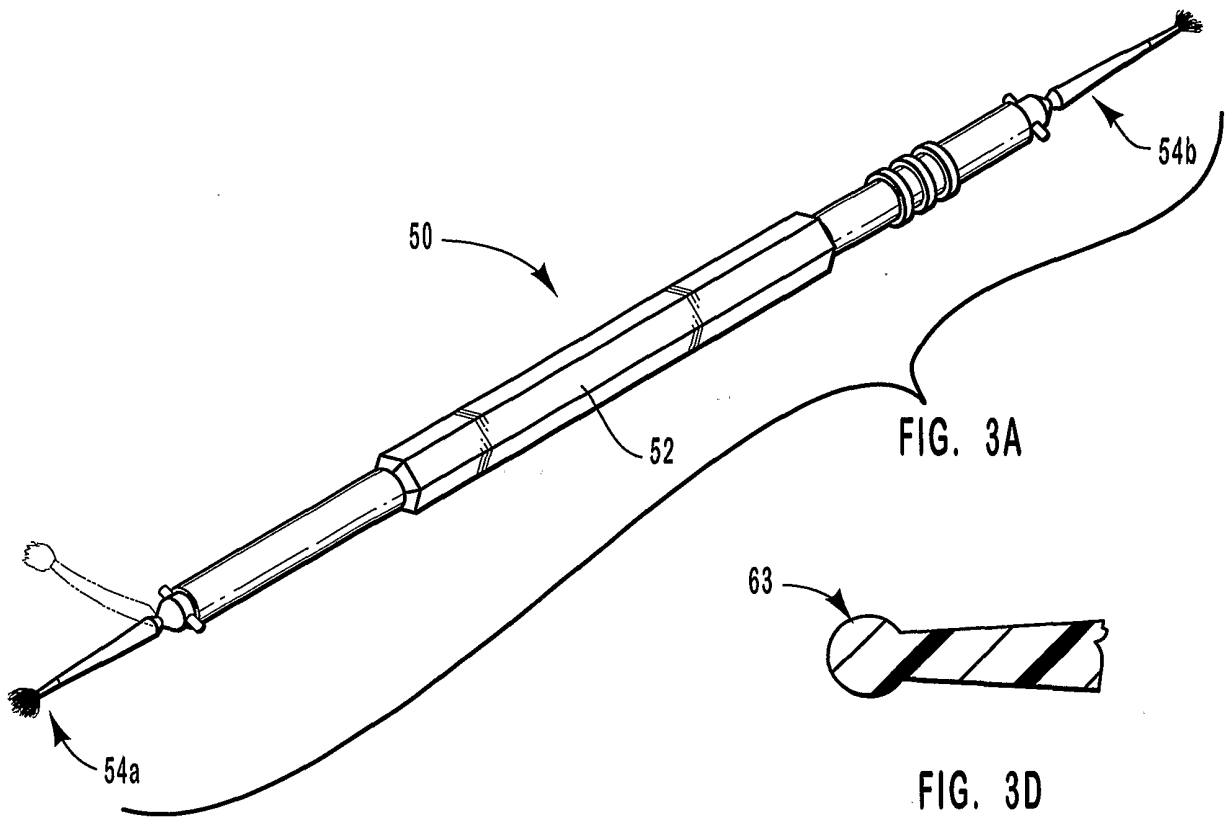

FIG. 2D



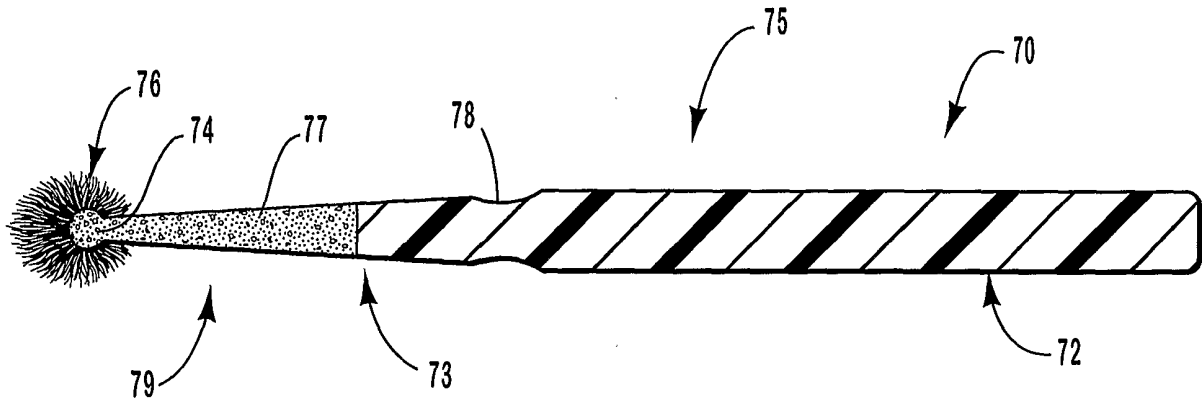

FIG. 4A

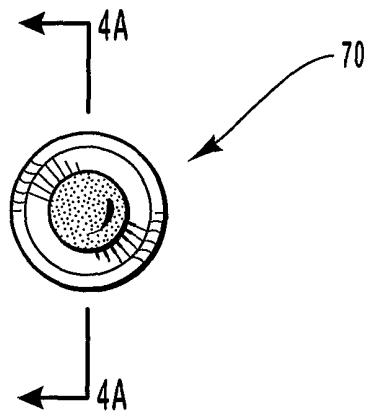

FIG. 4B

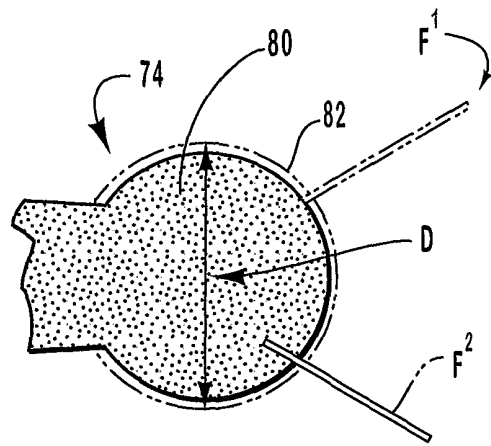

FIG. 4C

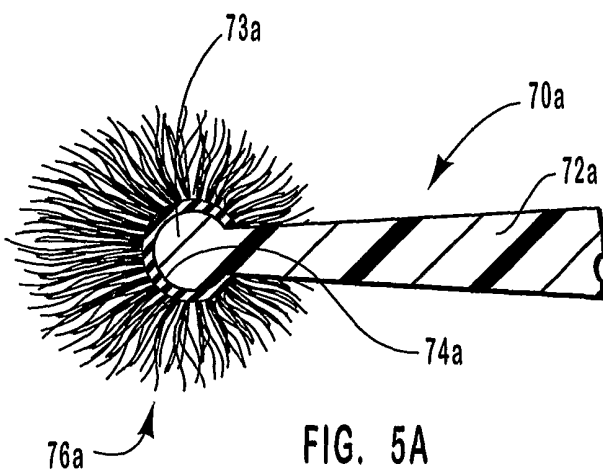

FIG. 5A

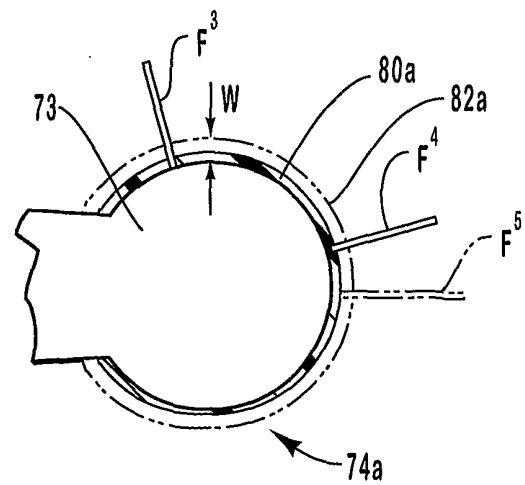

FIG. 5B

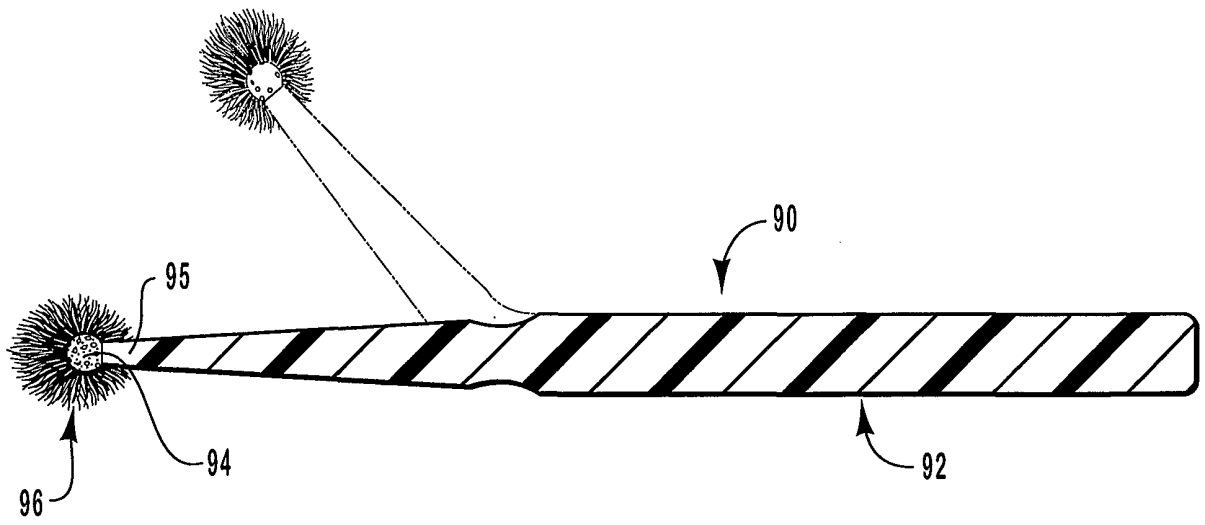

FIG. 6A

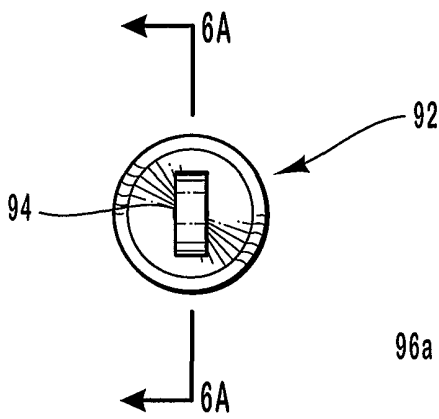

FIG. 6B

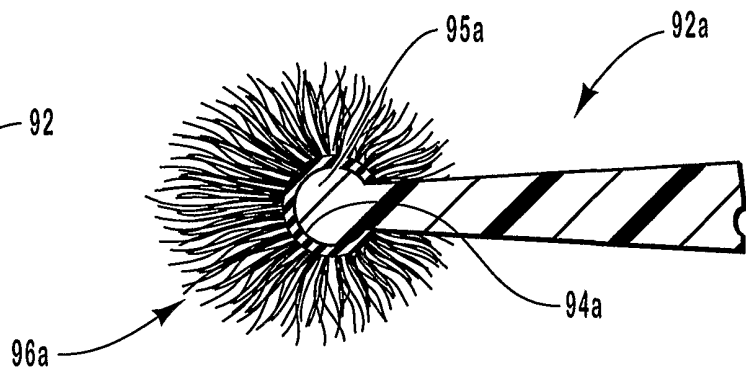

FIG. 7A

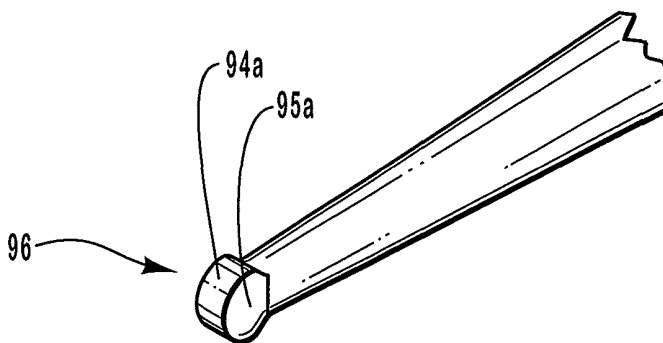

FIG. 7B

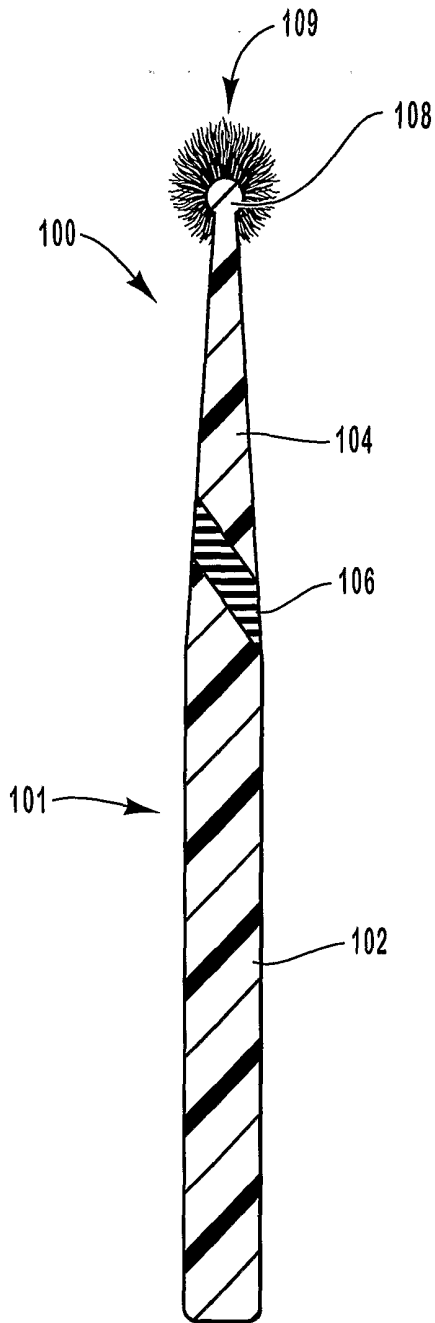

FIG. 8A

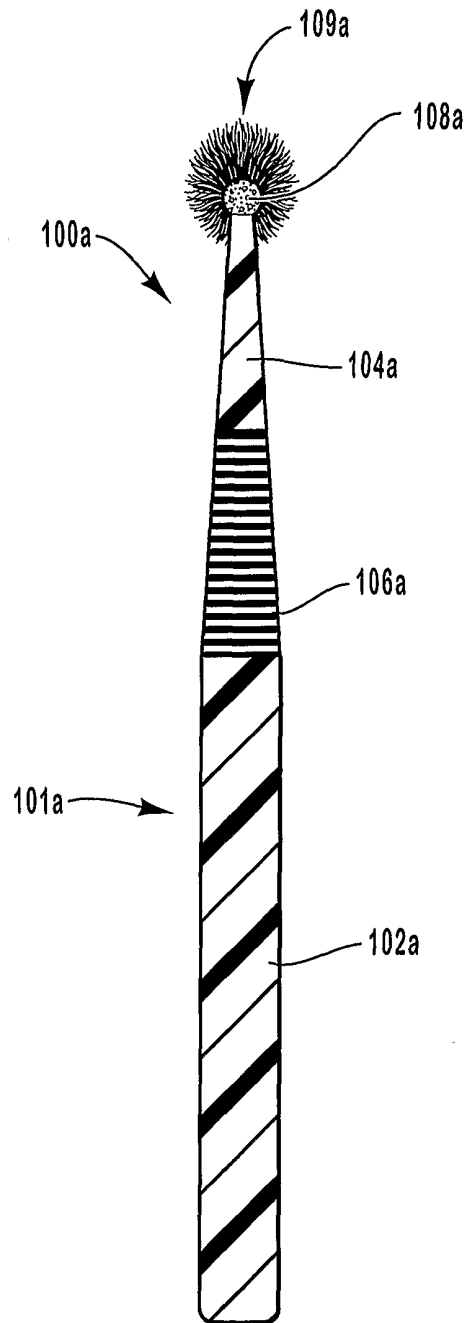

FIG. 8B

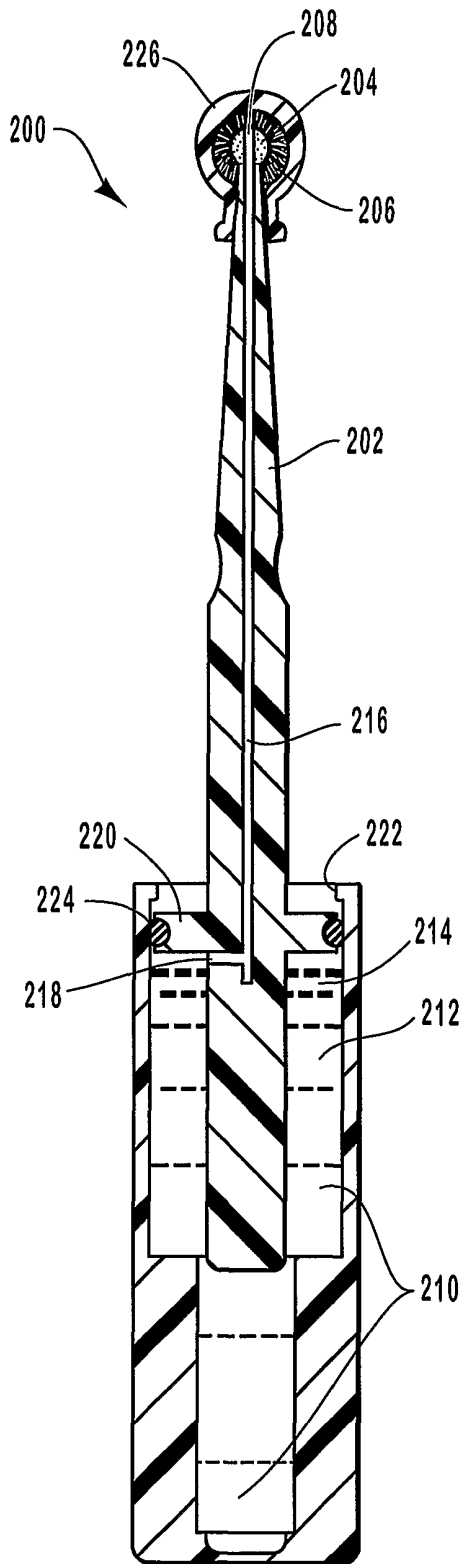

FIG. 9A

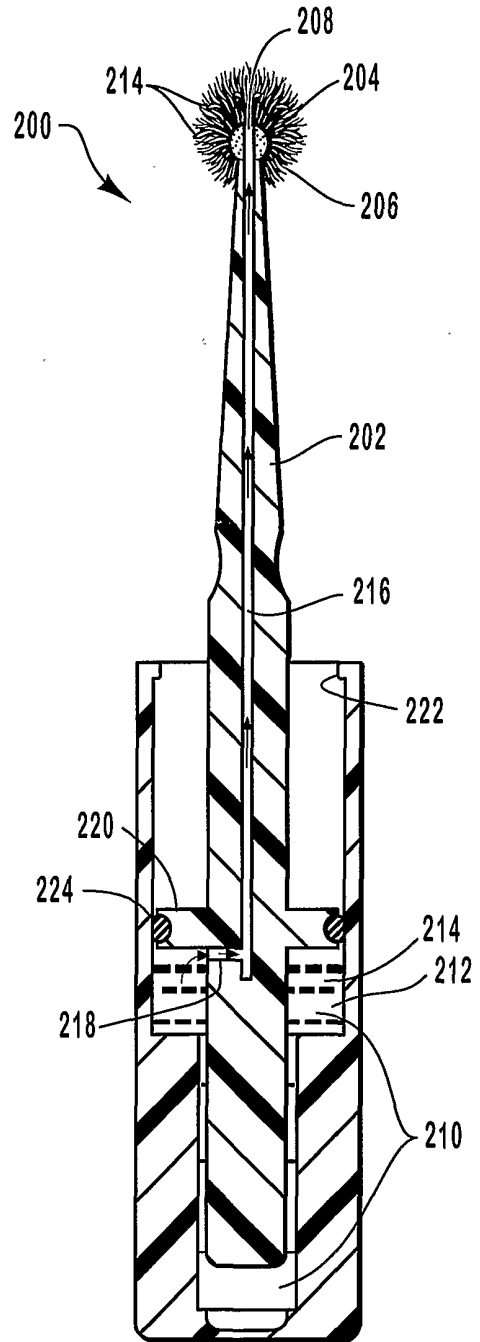

FIG. 9B

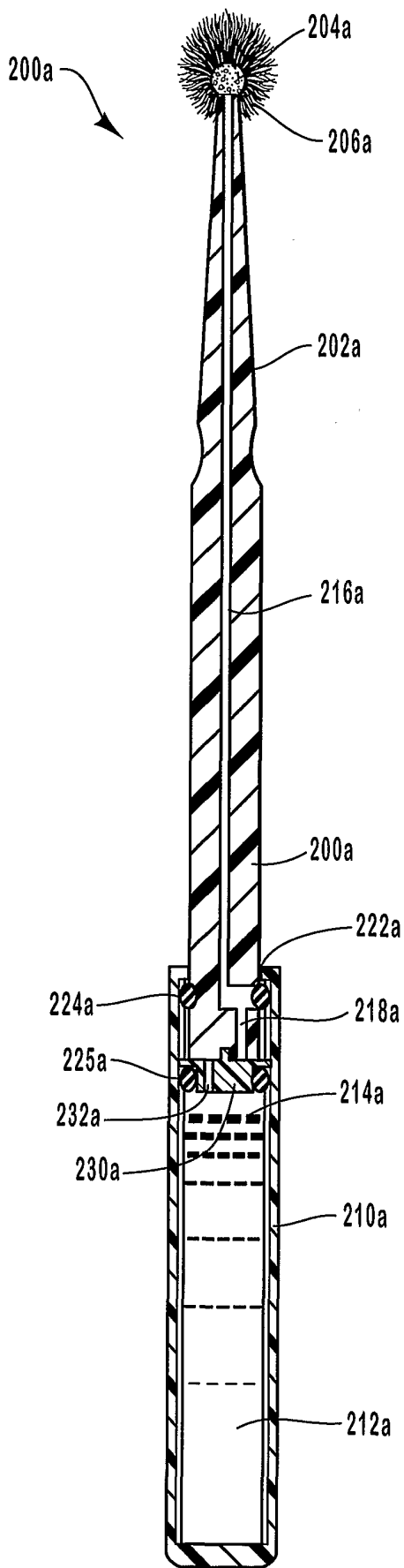

FIG. 10A

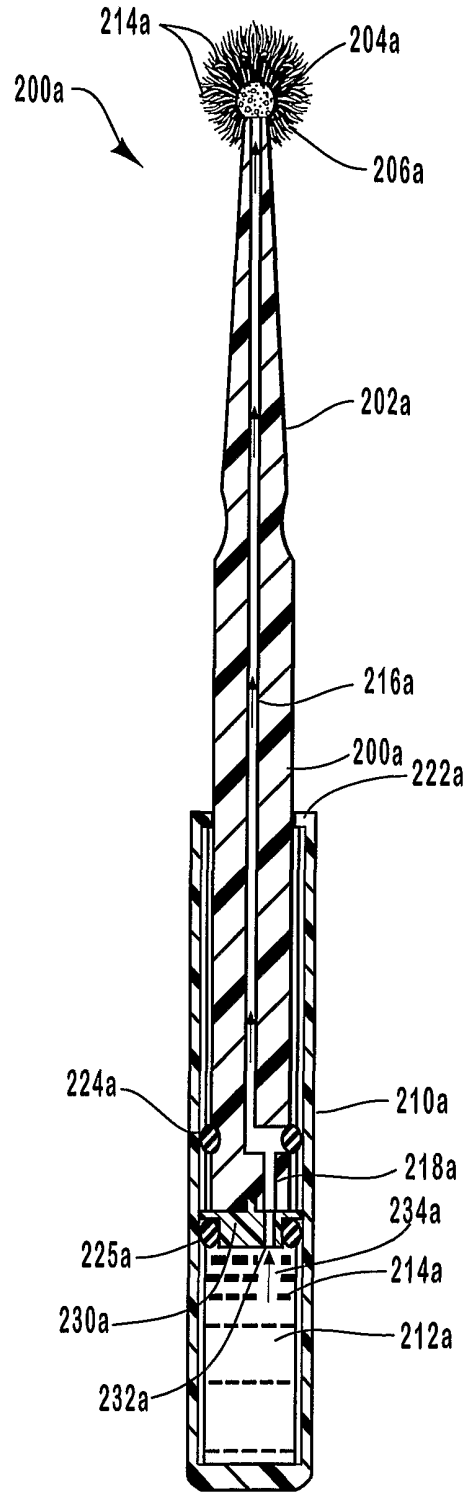

FIG. 10B

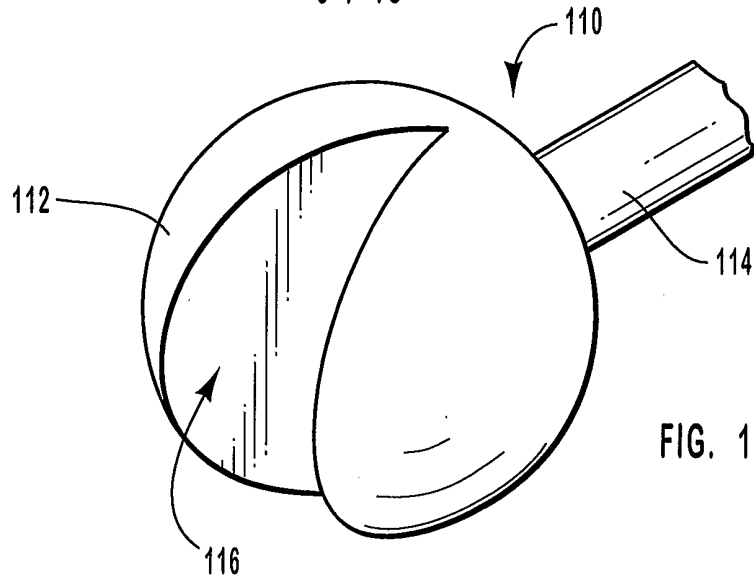

FIG. 11A

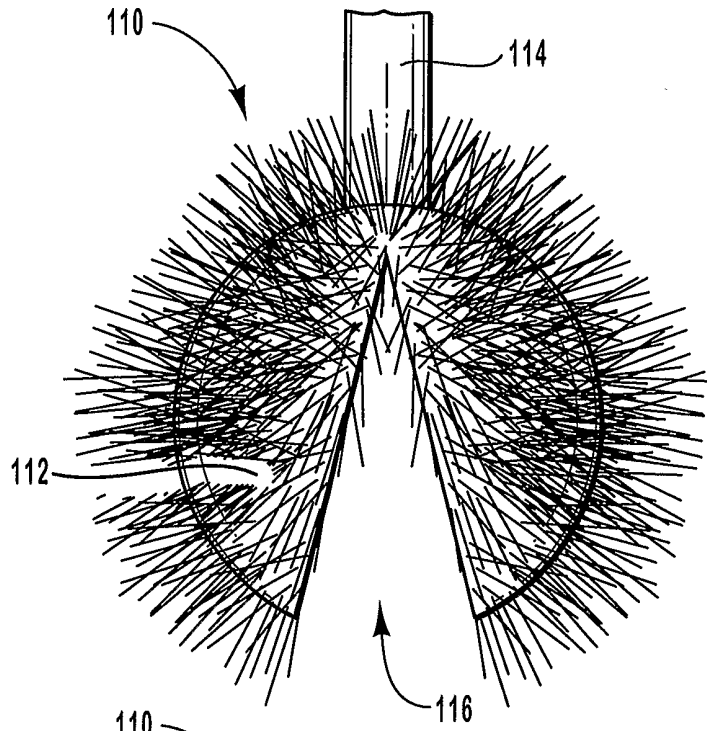

FIG. 11B

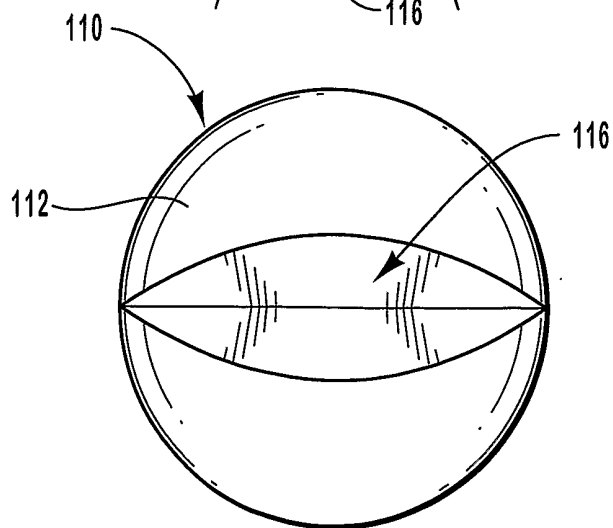

FIG. 11C

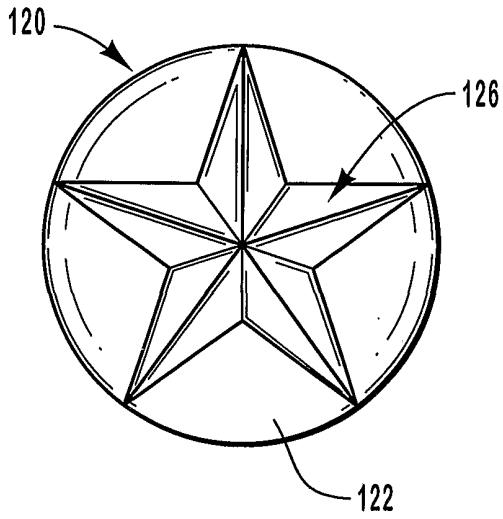

FIG. 12A

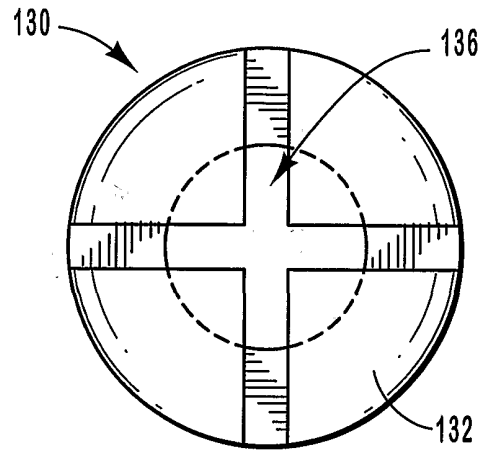

FIG. 13A

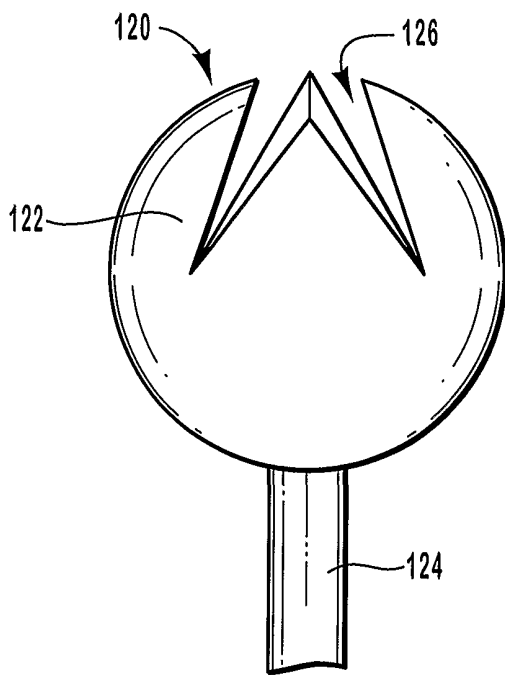

FIG. 12B

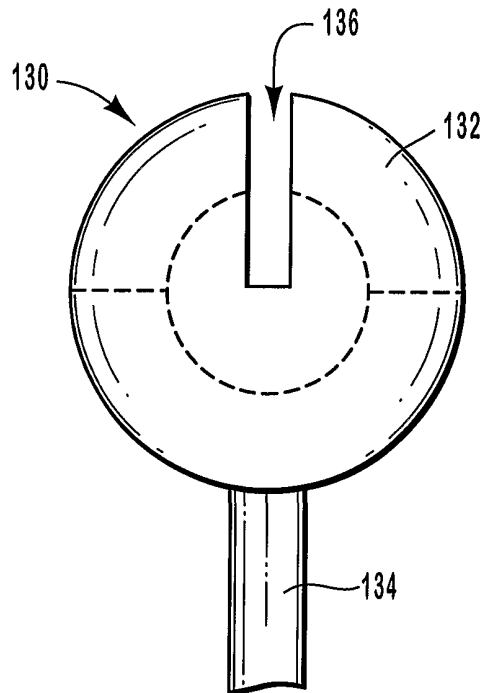

FIG. 13B

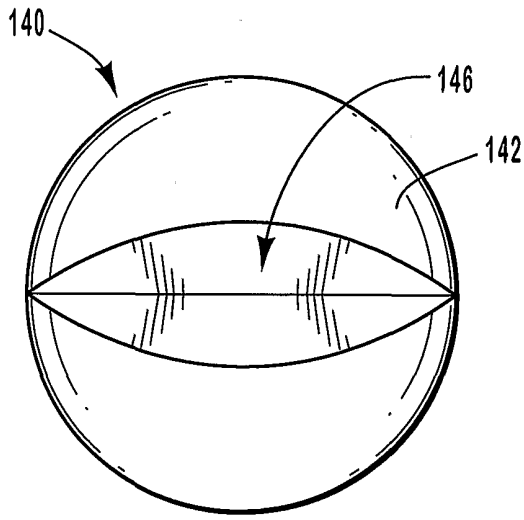

FIG. 14A

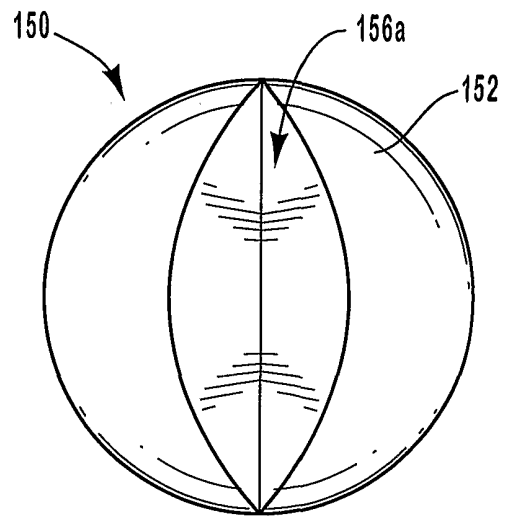

FIG. 15A

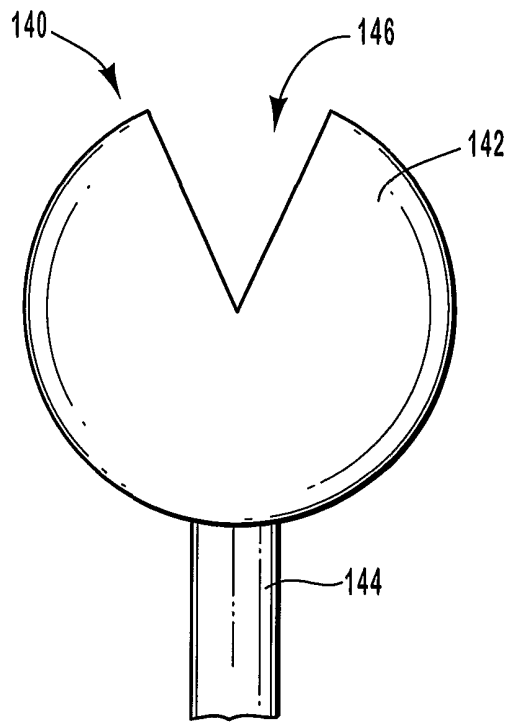

FIG. 14B

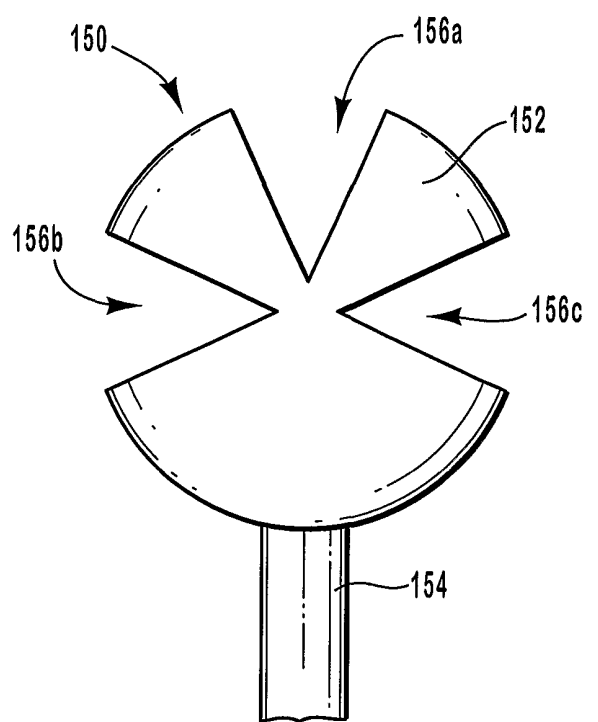

FIG. 15B

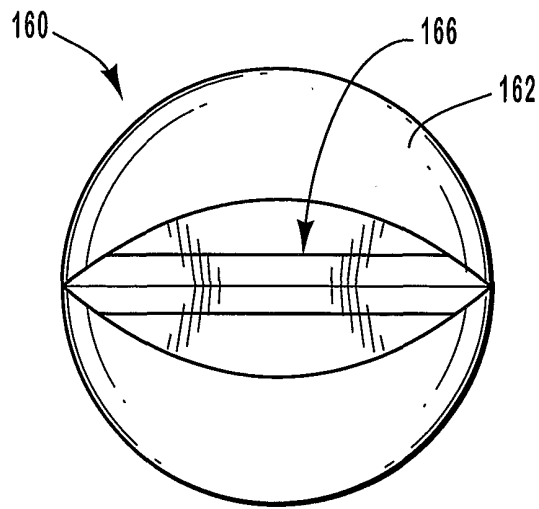

FIG. 16A

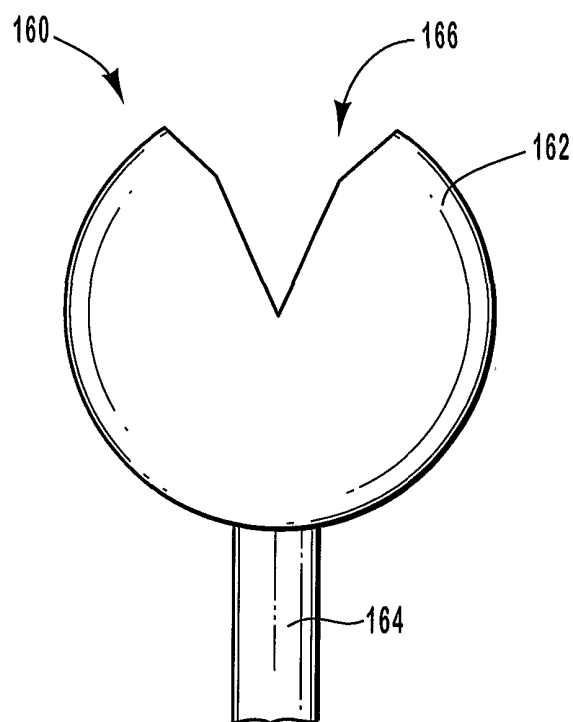

FIG. 16B

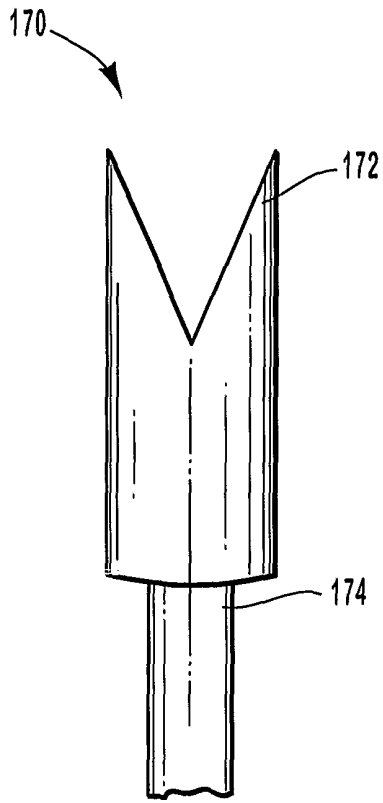

FIG. 17A

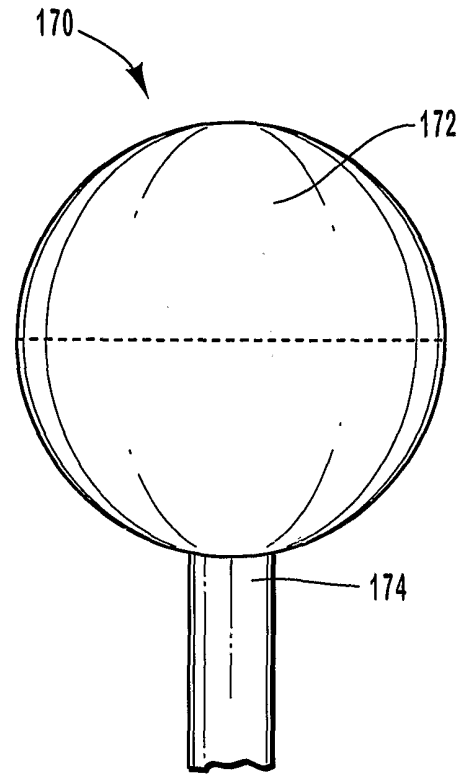

FIG. 17B

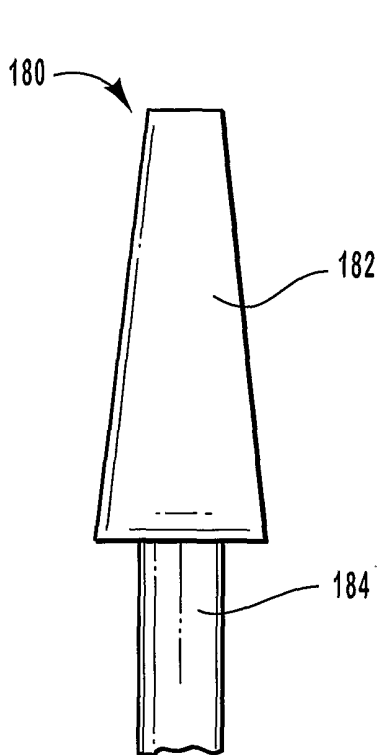

FIG. 18A

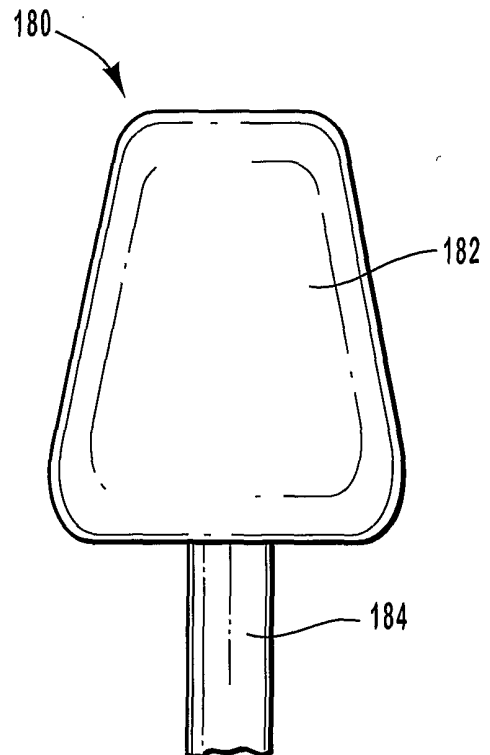
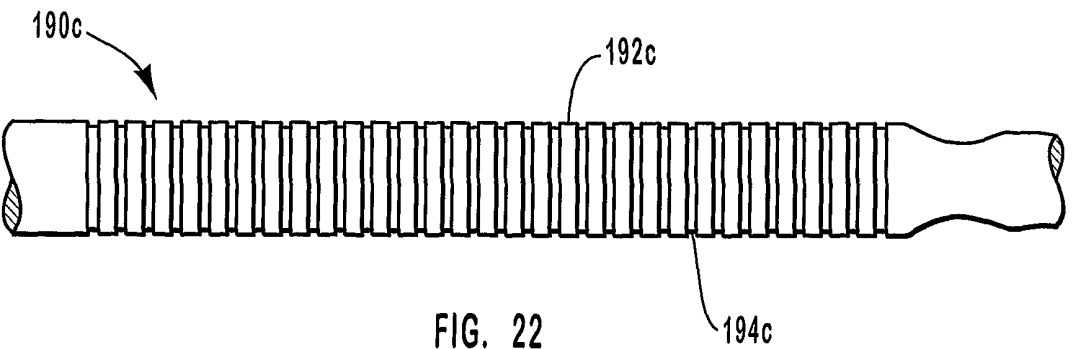
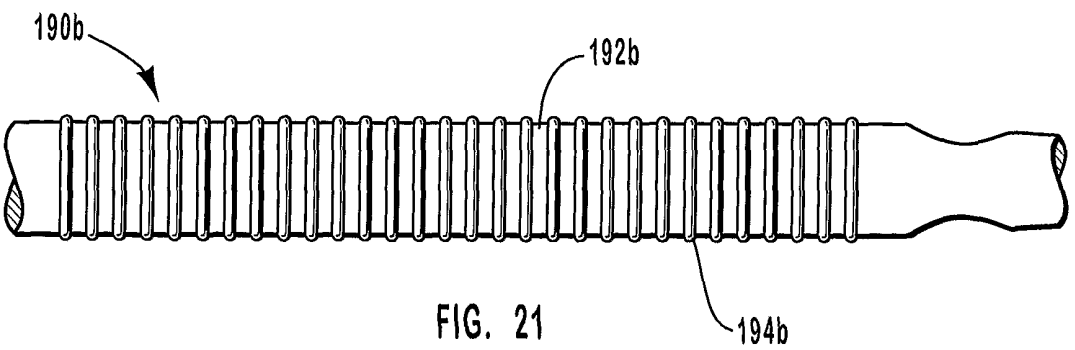
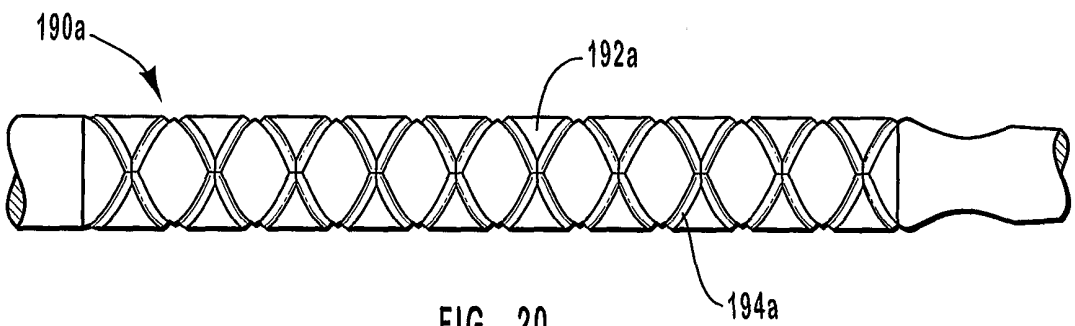
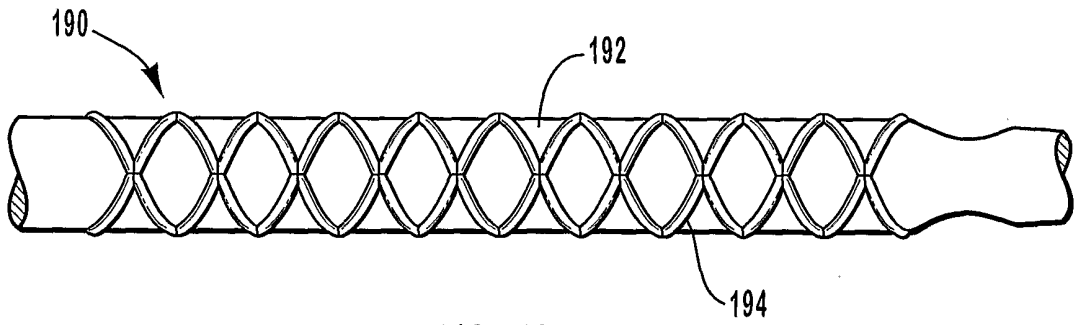

FIG. 18B



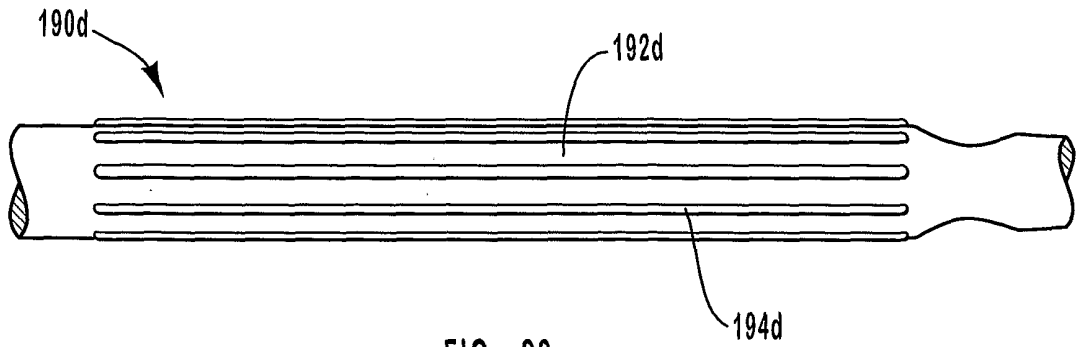

FIG. 23

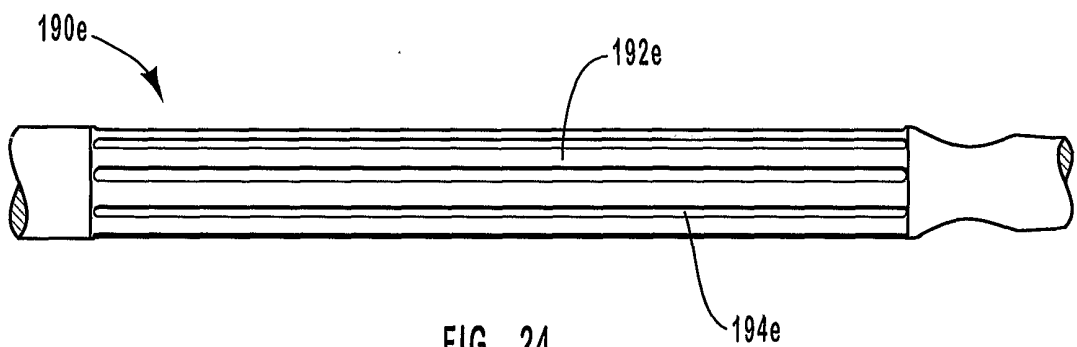

FIG. 24

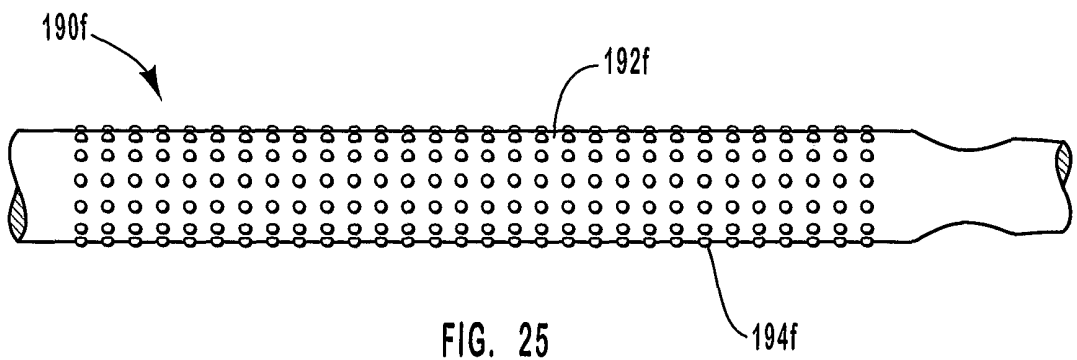

FIG. 25

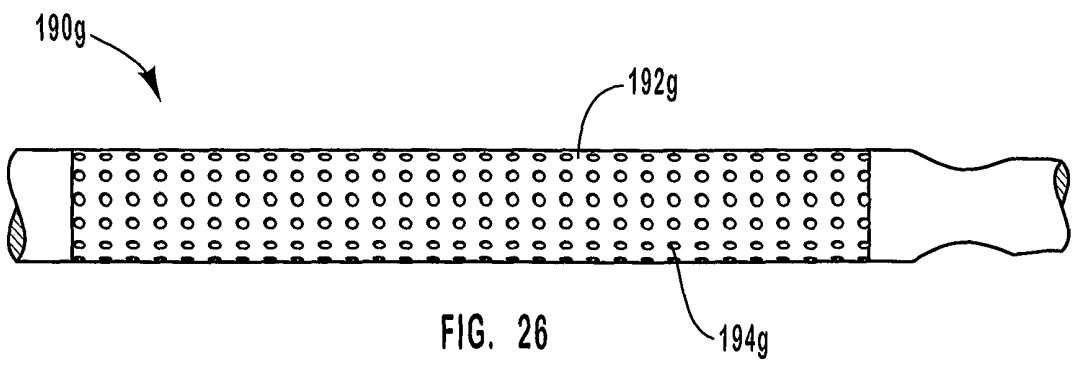

FIG. 26

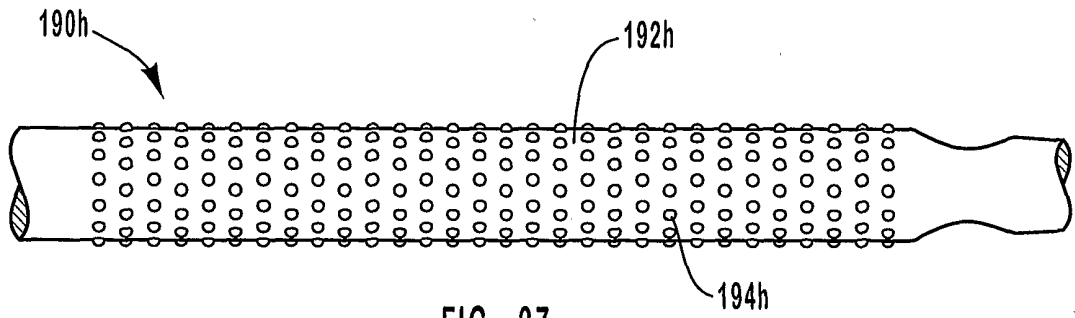

FIG. 27

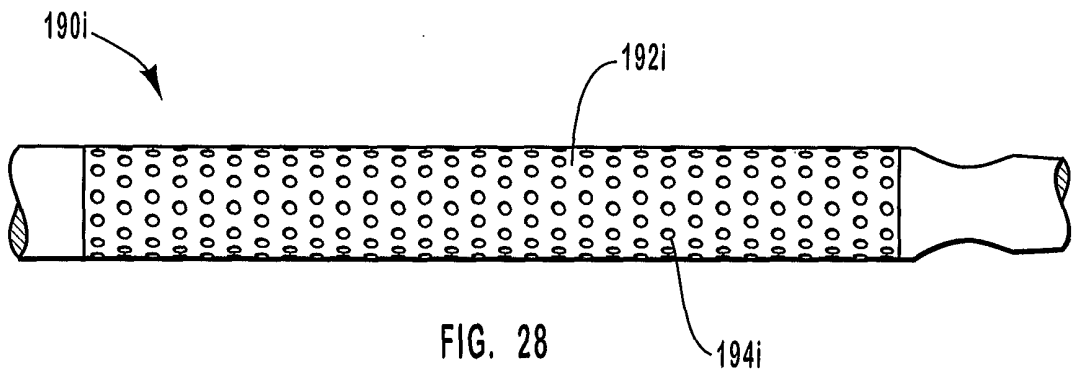

FIG. 28

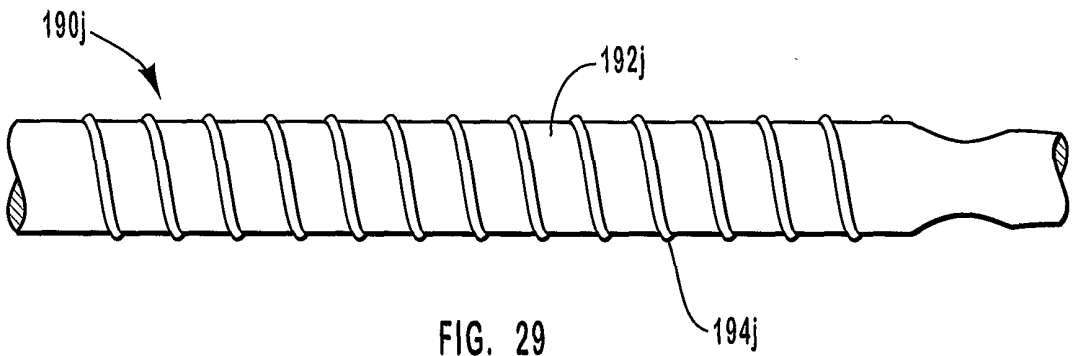

FIG. 29

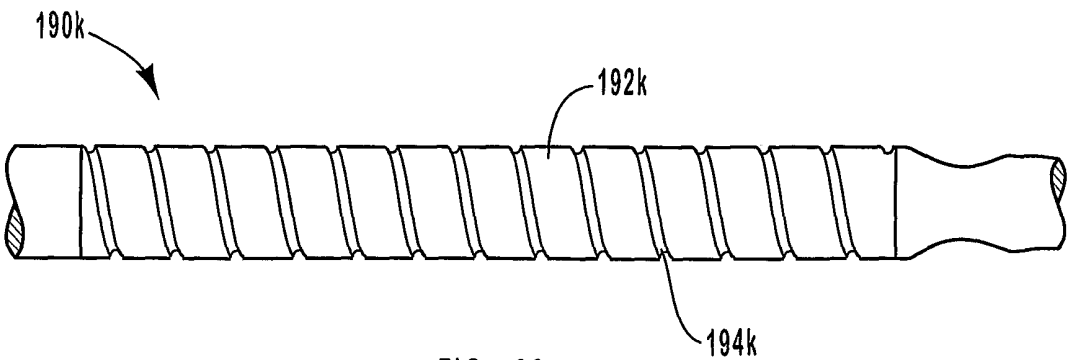

FIG. 30

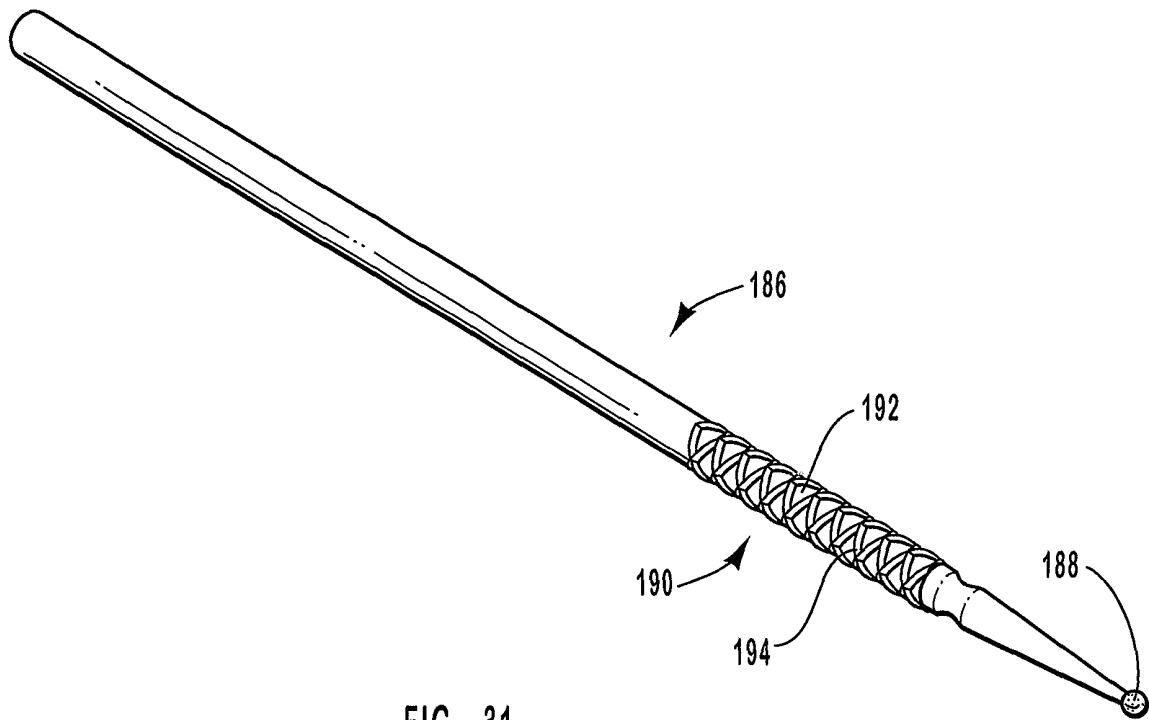

FIG. 31

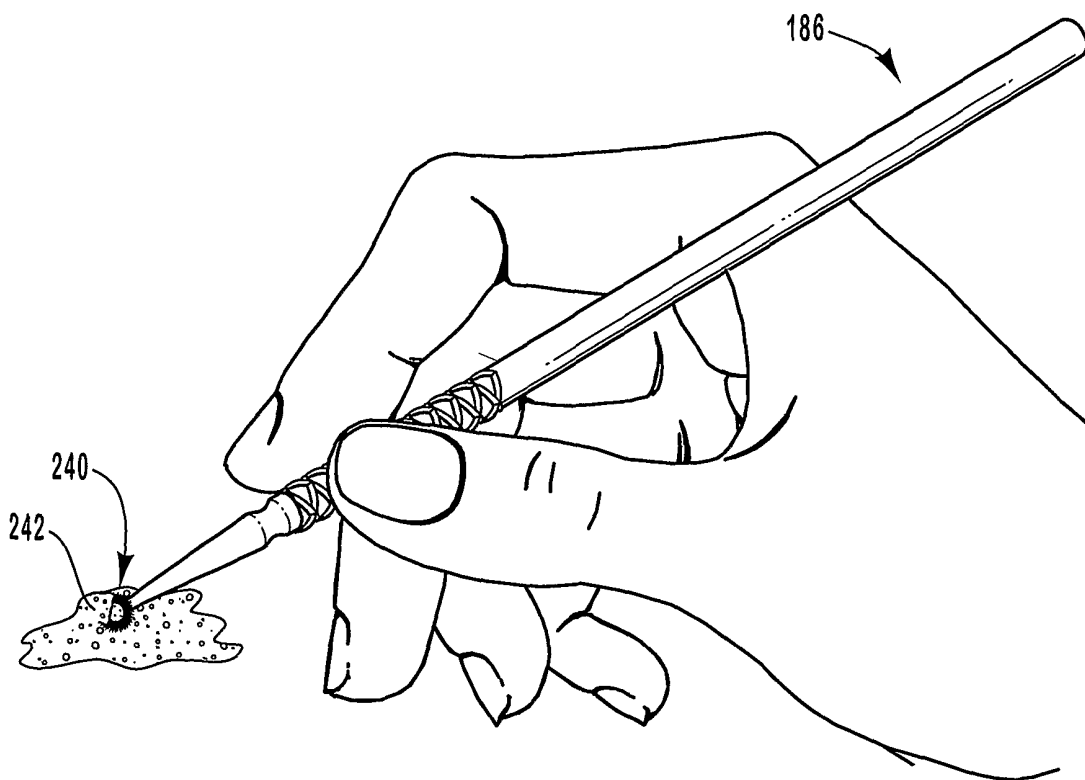

FIG. 32

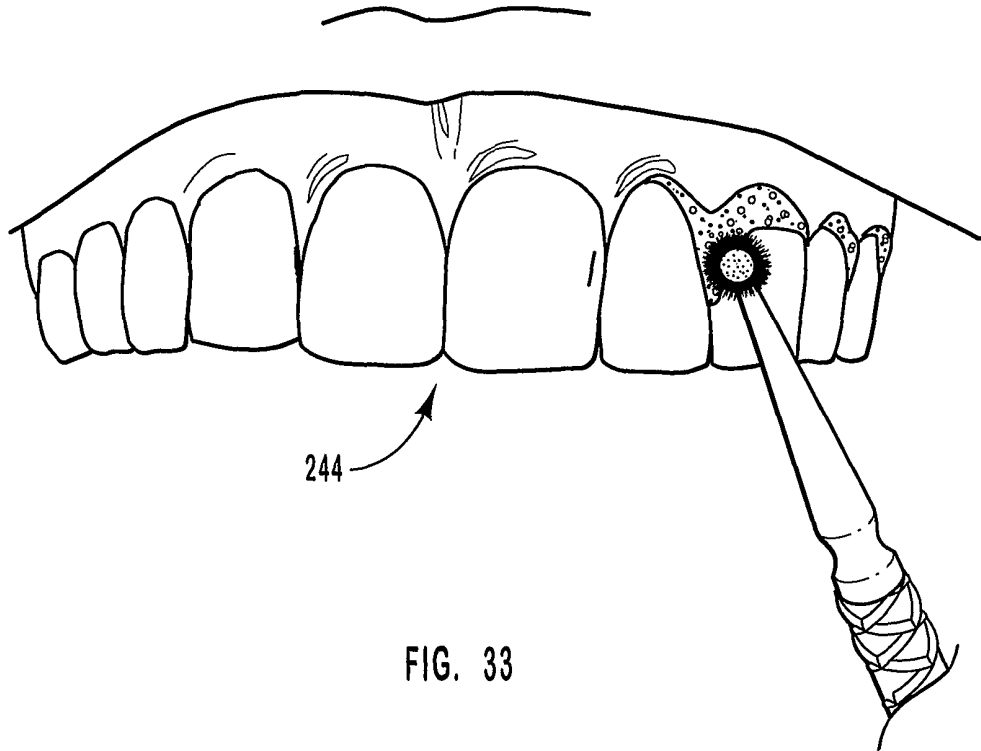
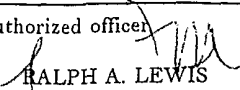

FIG. 33

INTERNATIONAL SEARCH REPORT

International application No.

PCT/US01/42676

A. CLASSIFICATION OF SUBJECT MATTER		
IPC(7) :A61C 5/04 US CL :433/80 According to International Patent Classification (IPC) or to both national classification and IPC		
B. FIELDS SEARCHED		
Minimum documentation searched (classification system followed by classification symbols) U.S. : 433/80, 89, 90; 604/1, 2, 311		
Documentation searched other than minimum documentation to the extent that such documents are included in the fields searched		
Electronic data base consulted during the international search (name of data base and, where practicable, search terms used)		
C. DOCUMENTS CONSIDERED TO BE RELEVANT		
Category*	Citation of document, with indication, where appropriate, of the relevant passages	Relevant to claim No.
X	US 4,718,889 A (BLASIUS, Jr. et al) 12 January 1988, see entire document	1-3,5,10,16 ,18, 20-28
X	US 5,630,244 A (CHANG) 20 May 1997. see entire document.	1-3,8,9,15, 17,19, 25,
Y		28,30-32
A	US 5,816,804 A (FISCHER) 06 October 1998, see Figures.	1-32
A	US 6,059,570 A (DRAGAN et al) 09 May 2000, see Figures.	1-32
X	US 6,082,999 A (TCHERNY et al) 04 July 2000, see entire document.	1-3,5,8,9, 17,24,25, 28
<input checked="" type="checkbox"/> Further documents are listed in the continuation of Box C. <input type="checkbox"/> See patent family annex.		
* Special categories of cited documents:	"T"	later document published after the international filing date or priority date and not in conflict with the application but cited to understand the principle or theory underlying the invention
"A" document defining the general state of the art which is not considered to be of particular relevance	"X"	document of particular relevance; the claimed invention cannot be considered novel or cannot be considered to involve an inventive step when the document is taken alone
"E" earlier document published on or after the international filing date	"Y"	document of particular relevance; the claimed invention cannot be considered to involve an inventive step when the document is combined with one or more other such documents, such combination being obvious to a person skilled in the art
"L" document which may throw doubts on priority claim(s) or which is cited to establish the publication date of another citation or other special reason (as specified)	"G"	document member of the same patent family
"O" document referring to an oral disclosure, use, exhibition or other means		
"P" document published prior to the international filing date but later than the priority date claimed		
Date of the actual completion of the international search 20 DECEMBER 2001	Date of mailing of the international search report 09 JAN 2002	
Name and mailing address of the ISA/US Commissioner of Patents and Trademarks Box PCT Washington, D.C. 20231 Facsimile No. (703) 305-3230	Authorized officer  RALPH A. LEWIS Telephone No. (703) 308-0770	

INTERNATIONAL SEARCH REPORT

International application No.
PCT/US01/42676

C (Continuation). DOCUMENTS CONSIDERED TO BE RELEVANT

Category*	Citation of document, with indication, where appropriate, of the relevant passages	Relevant to claim No.
X, P	US 6,162,202 A (SICURELLI et al) 19 December 2000, see entire document.	1,2,3,5, 7-9,12-14, 24,25,28