



(51) International Patent Classification:

C08B 3/02 (2006.01) H01M 8/04007 (2016.01)  
C25B 1/00 (2006.01) H01M 8/0612 (2016.01)  
C25B 15/02 (2006.01) H01M 8/0656 (2016.01)

(21) International Application Number:

PCT/US2016/062276

(22) International Filing Date:

16 November 2016 (16.11.2016)

(25) Filing Language:

English

(26) Publication Language:

English

(30) Priority Data:

62/256,515 17 November 2015 (17.11.2015) US

(71) Applicant: FUELCELL ENERGY, INC. [US/US]; 3 Great Pasture Road, Danbury, Connecticut 06810 (US).

(72) Inventors: JAHNKE, Fred C.; 2 Winthrop Street, Rye, New York 10580 (US). LAMBRECH, Matthew; 3 Briarwood Drive, Sherman, Connecticut 06784 (US).

(74) Agents: SPROW, Marcus et al.; Foley & Lardner LLP, 3000 K Street, N.W. Suite 600, Washington, District of Columbia 20007-5109 (US).

(81) Designated States (unless otherwise indicated, for every kind of national protection available): AE, AG, AL, AM, AO, AT, AU, AZ, BA, BB, BG, BH, BN, BR, BW, BY,

BZ, CA, CH, CL, CN, CO, CR, CU, CZ, DE, DJ, DK, DM, DO, DZ, EC, EE, EG, ES, FI, GB, GD, GE, GH, GM, GT, HN, HR, HU, ID, IL, IN, IR, IS, JP, KE, KG, KN, KP, KR, KW, KZ, LA, LC, LK, LR, LS, LU, LY, MA, MD, ME, MG, MK, MN, MW, MX, MY, MZ, NA, NG, NI, NO, NZ, OM, PA, PE, PG, PH, PL, PT, QA, RO, RS, RU, RW, SA, SC, SD, SE, SG, SK, SL, SM, ST, SV, SY, TH, TJ, TM, TN, TR, TT, TZ, UA, UG, US, UZ, VC, VN, ZA, ZM, ZW.

(84) Designated States (unless otherwise indicated, for every kind of regional protection available): ARIPO (BW, GH, GM, KE, LR, LS, MW, MZ, NA, RW, SD, SL, ST, SZ, TZ, UG, ZM, ZW), Eurasian (AM, AZ, BY, KG, KZ, RU, TJ, TM), European (AL, AT, BE, BG, CH, CY, CZ, DE, DK, EE, ES, FI, FR, GB, GR, HR, HU, IE, IS, IT, LT, LU, LV, MC, MK, MT, NL, NO, PL, PT, RO, RS, SE, SI, SK, SM, TR), OAPI (BF, BJ, CF, CG, CI, CM, GA, GN, GQ, GW, KM, ML, MR, NE, SN, TD, TG).

Declarations under Rule 4.17:

— as to applicant's entitlement to apply for and be granted a patent (Rule 4.17(ii))

Published:

— with international search report (Art. 21(3))  
— with amended claims (Art. 19(1))

(54) Title: HYDROGEN AND CARBON MONOXIDE GENERATION USING AN REP WITH PARTIAL OXIDATION

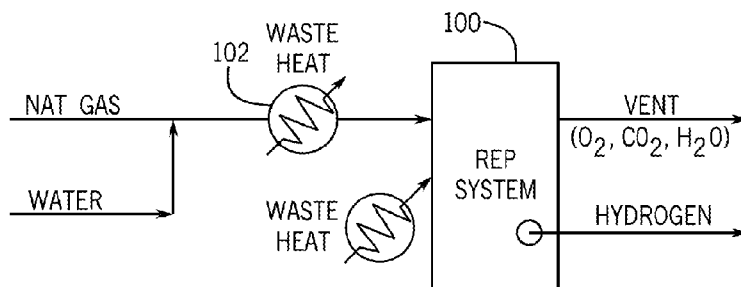

FIG. 1

(57) Abstract: A system for producing at least one of hydrogen or carbon monoxide includes at least one fuel cell, including an anode and a cathode separated by an electrolyte matrix. The at least one fuel cell further includes a power supply for applying a reverse voltage to the at least one fuel cell to operate the fuel cell in reverse as an electrolyzer. The anode is configured to receive a partially-reformed fuel and output a gas comprising hydrogen. The cathode is configured to output a gas comprising carbon dioxide and oxygen. The system further includes at least one oxidizer configured to receive the carbon dioxide and oxygen from the cathode and fuel from a fuel supply, the at least one oxidizer configured to output a partially-oxidized fuel comprising carbon monoxide, carbon dioxide, and hydrogen.

WO 2017/087518 A1

## Hydrogen and Carbon Monoxide Generation Using an REP with Partial Oxidation

### CROSS-REFERENCE TO RELATED PATENT APPLICATIONS

**[0001]** The present application claims the benefit of and priority to U.S. Provisional Patent Application No. 62/256,515, filed November 17, 2015, the entire disclosure of which is incorporated herein by reference.

### BACKGROUND

**[0002]** The present application relates generally to the field of H<sub>2</sub> (“hydrogen”) and/or CO (“carbon monoxide”) generation using fuel cells with partial oxidation.

**[0003]** A reformer-electrolyzer-purifier (“REP”) may be used to generate hydrogen and/or carbon monoxide. Examples of REPs and systems that include them are described in PCT Publication No. WO 2015/116964, which is assigned to the assignee of the present application.

### SUMMARY

**[0004]** In one embodiment, a system for producing at least one of hydrogen or carbon monoxide includes at least one fuel cell, including an anode and a cathode separated by an electrolyte matrix. The at least one fuel cell further includes a power supply for applying a reverse voltage to the at least one fuel cell to operate the fuel cell in reverse as an electrolyzer. The anode is configured to receive a partially-reformed fuel and output a gas comprising hydrogen. The cathode is configured to output a gas comprising carbon dioxide and oxygen. The system further includes at least one oxidizer configured to receive the carbon dioxide and oxygen from the cathode and fuel from a fuel supply, the at least one oxidizer configured to output a partially-oxidized fuel comprising carbon monoxide, carbon dioxide, and hydrogen.

**[0005]** In one aspect of the system, the system further includes a heat source configured to generate heat and exhaust.

**[0006]** In one aspect of the system, the heat source is a fired heater.

**[0007]** In one aspect of the system, the system further includes a reformer configured to receive fuel from the fuel supply and at least one of steam or water.

**[0008]** In one aspect of the system, the reformer is configured to transfer heat from the heat source to the fuel and to the at least one of steam or water, and the reformer is configured to at least partially reform the fuel and at least one of steam or water.

**[0009]** In one aspect of the system, the system further includes a pre-heater configured to pre-heat the fuel before the fuel is received in the reformer.

**[0010]** In one aspect of the system, the pre-heater is configured to pre-heat the fuel using waste heat.

**[0011]** In one aspect of the system, the system further includes an air supply heat exchanger configured to transfer heat generated by the heat source to air received by the heat source.

**[0012]** In one aspect of the system, the heat source is configured to vent exhaust out of the system.

**[0013]** In another embodiment, a method of generating at least one of hydrogen or carbon monoxide using the system includes receiving, at the anode of the fuel cell, partially-reformed fuel and at least one of steam or water, and outputting hydrogen from the anode of the fuel cell. The method further includes outputting carbon dioxide and oxygen from the cathode of the fuel cell. The method further includes receiving, at the at least one oxidizer, carbon dioxide and oxygen from the cathode and fuel from the fuel source. The method further includes outputting carbon monoxide from the at least one oxidizer.

**[0014]** In one aspect of the method, the method further includes venting exhaust generated by the heat source after heat is transferred from the exhaust by at least one of a reformer or a heat exchanger.

**[0015]** In one aspect of the method, the method further includes transferring heat from exhaust generated by the heat source to the fuel in at least one of a reformer or a heat exchanger.

**[0016]** In one aspect of the method, the method further includes transferring heat from exhaust generated by the heat source to at least one of steam or water in at least one of a reformer or a heat exchanger.

**[0017]** In one aspect of the method, the method further includes mixing hydrogen output from the anode of the fuel cell and carbon monoxide output from the at least one oxidizer to form a syngas.

**[0018]** In one aspect of the method, the method further includes desulfurizing the fuel prior to feeding the fuel to a reformer.

**[0019]** In another embodiment, a system for producing at least one of hydrogen or carbon monoxide includes at least one fuel cell, including an anode and a cathode separated by an electrolyte matrix, and a power supply for applying a reverse voltage to the at least one fuel cell to operate the fuel cell in reverse as an electrolyzer. The at least one fuel cell further includes a reforming cell configured to receive fuel from a fuel supply and at least one of steam or water, the reforming cell configured to output a partially-reformed fuel. The reforming cell is configured to feed the partially-reformed fuel to the anode and the cathode. The anode is configured to receive the partially-reformed fuel and output a gas comprising hydrogen. The cathode is configured to receive and at least partially oxidize at least one of the fuel from the fuel supply or the partially-reformed fuel. The cathode is configured to output carbon monoxide, hydrogen, and carbon dioxide.

**[0020]** In one aspect of the system, the cathode further includes a catalyst configured to partially oxidize the partially-reformed fuel.

**[0021]** In one aspect of the system, the cathode is configured to output primarily carbon monoxide.

**[0022]** In one aspect of the system, the system further includes a heat source configured to generate heat and exhaust.

**[0023]** In one aspect of the system, the system further includes a first heat exchanger configured to transfer heat from the heat source to fuel from the fuel supply and at least one of steam or water.

**[0024]** In one aspect of the system, the heat source is a fired heater.

**[0025]** In one aspect of the system, the heat source is configured to vent exhaust out of the system.

[0026] In one aspect of the system, the system further includes a pre-reformer configured to receive fuel from the fuel supply and at least one of steam or water.

[0027] In one aspect of the system, the system further includes a pre-heater configured to pre-heat the fuel before the fuel is received in the reforming cell.

[0028] In one aspect of the system, the pre-heater is configured to pre-heat the fuel using waste heat.

[0029] In one aspect of the system, the fuel from the fuel supply is methane.

[0030] In another embodiment, a method of generating at least one of hydrogen or carbon monoxide with the system includes receiving, at the reforming cell, methane and steam, and outputting a partially-reformed fuel from the reforming cell. The method further includes receiving, at the anode, the partially-reformed fuel from the reforming cell, and outputting hydrogen from the anode. The method further includes receiving, at the cathode, the partially-reformed fuel from the reforming cell, and outputting at least carbon monoxide from the cathode. The method further includes receiving, at the cathode, fuel from the fuel supply and at least one of steam or water.

[0031] In one aspect of the method, the method further includes using a reforming reaction in the reforming cell to remove at least a portion of heat generated in an oxidation reaction in the cathode.

[0032] In one aspect of the method, the method further includes desulfurizing fuel from the fuel supply prior to feeding the fuel to the reforming cell.

[0033] In one aspect of the method, the method further includes mixing hydrogen output from the anode of the fuel cell and carbon monoxide output from the cathode of the fuel cell to form a syngas.

[0034] In another embodiment, a system for producing hydrogen includes at least one fuel cell, including an anode and a cathode separated by an electrolyte matrix, and a power supply for applying a reverse voltage to the at least one fuel cell to operate the fuel cell in reverse as an electrolyzer. The system further includes an oxidizer configured to receive fuel from a fuel supply and at least one of steam or water, the oxidizer configured to output a partially-reformed

fuel. The anode is configured to receive the partially-reformed fuel from the oxidizer and to output hydrogen. The cathode is configured to output carbon dioxide and oxygen to the oxidizer.

**[0035]** In one aspect of the system, the system further includes a heater configured to heat the fuel and at least one of steam or water.

**[0036]** In one aspect of the system, the heater is configured to receive a portion of the partially-reformed fuel output by the oxidizer.

**[0037]** In one aspect of the system, the heater is configured to combust the partially-reformed fuel to generate heat.

**[0038]** In one aspect of the system, the heater is configured to vent exhaust out of the system.

**[0039]** In one aspect of the system, the fuel is diesel fuel or JP8.

**[0040]** In one aspect of the system, the system further includes a pre-heater configured to pre-heat the fuel and the at least one of steam or water before the fuel and the at least one of steam or water are received in the heater.

**[0041]** In one aspect of the system, the pre-heater is configured to pre-heat the fuel using waste heat.

**[0042]** In another embodiment, a method of generating hydrogen with the system includes receiving, at the oxidizer, fuel and steam, and outputting partially-oxidized fuel from the oxidizer. The method further includes receiving, at the anode, the partially-oxidized fuel, and outputting hydrogen from the anode. The method further includes outputting carbon dioxide and oxygen from the cathode. The method further includes receiving, at the oxidizer, carbon dioxide and oxygen from the cathode.

**[0043]** In one aspect of the method, the method further includes oxidizing fuel and steam from the heater with the carbon dioxide and oxygen output from the cathode.

**[0044]** In one aspect of the method, the method further includes desulfurizing the partially-oxidized fuel prior to feeding the partially-oxidized fuel to the anode.

[0045] In one aspect of the method, the method further includes feeding a portion of the partially-oxidized fuel from the oxidizer to a heater configured to heat the fuel and at least one of steam or water.

[0046] In one aspect of the method, the method further includes desulfurizing the portion of the partially-oxidized fuel before it is received by the heater.

[0047] In one aspect of the method, the method further includes combusting the portion of the partially-oxidized fuel to generate heat in the heater.

[0048] In one aspect of the method, the method further includes venting exhaust generated by the heater out of the system.

#### BRIEF DESCRIPTION OF THE DRAWINGS

[0049] FIG. 1 shows a schematic view of the reformer-electrolyzer-purifier (“REP”) system including a REP assembly of the present invention;

[0050] FIG. 2 shows a more detailed view of the REP system;

[0051] FIG. 3 shows reactions occurring in in the REP assembly;

[0052] FIG. 4 shows gasification/partial oxidation separate from the REP system;

[0053] FIG. 5 shows partial oxidation integrated with the REP system; and

[0054] FIG. 6 shows a system for generating hydrogen with low-cost sulfur-containing liquid fuels.

#### DETAILED DESCRIPTION

[0055] A reformer-electrolyzer-purifier (“REP”) assembly includes at least one electrolyzer molten carbonate fuel cell and may include a plurality of electrolyzer fuel cells formed in a fuel cell stack, also referred to as a REP stack. The at least one electrolyzer fuel cell is a fuel cell operated in reverse so as to electrolyze CO<sub>2</sub> and water to produce H<sub>2</sub> (“hydrogen”), and to purify the hydrogen by removing the CO<sub>3</sub><sup>=</sup> electrochemically. The CO<sub>2</sub> may be provided by a hydrocarbon, such as methane, and removing the CO<sub>3</sub><sup>=</sup> drives the reforming reaction to

completion. Other reactions may occur in the at least one electrolyzer fuel cell, as described below and shown in the accompanying Figures.

**[0056]** The REP stack comprises a molten carbonate fuel cell (“MCFC”) stack and the REP assembly includes a power supply for supplying power to the REP stack for driving the electrolysis reaction. A controller may be included in the REP assembly and/or in the REP system for controlling the power supply and for controlling other operations and parts of the REP assembly and/or REP system. Control operations are described in more detail below. Although the specification describes the REP assembly, the REP stack and the REP system as including reforming, such as internal or external reforming, it is also contemplated that the REP assembly, the REP stack and/or the REP system may omit internal and/or external reforming, and may be used for electrolyzing a supply gas containing CO<sub>2</sub> and water and purifying hydrogen without reforming.

**[0057]** FIG. 1 shows a schematic view of an example of a REP system 100. As shown in FIG. 1, fuel, such as natural gas, anaerobic digester gas (“ADG”), or other suitable fuel, is pre-heated using waste heat (e.g., lower level heat) in a pre-heater 102 (e.g., a primary, first, or waste heat exchanger 416, 516, 616 as shown in FIGS. 4-6, respectively) and thereafter supplied to the REP system 100. The fuel may be humidified or mixed with water before or after being pre-heated. In the REP system 100, the fuel is reformed by reacting with steam to produce hydrogen, CO, and carbon dioxide, and hydrogen is purified at high temperature (reforming temperatures) by separating almost all of the carbon from the hydrogen, which drives the reforming reaction to completion. The REP system 100 outputs hydrogen and separately outputs other reaction products, including oxygen, and carbon dioxide. As shown, high level waste heat is supplied to the REP system 100 to provide heat for the endothermic reforming reaction such that substantially all of the fuel is converted to hydrogen, thereby reducing CO<sub>2</sub> emissions resulting from incomplete conversion of methane to hydrogen.

**[0058]** In one example of a hydrogen and/or carbon monoxide production system, described in PCT Publication No. WO 2015/116964, the hydrogen and/or carbon monoxide production system comprises a REP assembly including a REP stack 200 and a power supply 230. For example, FIG. 2 shows an illustrative configuration of such a hydrogen and/or carbon monoxide production system. The REP stack 200 comprises fuel cell components and may include one or more reforming only cells, or reforming units, 202 and one or more REP fuel cells 204, each of

which comprises an anode 204a and a cathode 204b separated by an electrolyte matrix. The REP fuel cells may be configured the same as conventional MCFC fuel cells but are operated in reverse by applying a reverse voltage of greater than 1.0 Volt, typically in the 1.15 to 1.35 Volt range. The reforming-only units 202 and REP fuel cells 204 are assembled in a stack and are connected in series so that fuel is first conveyed through the reforming only cells 202 and thereafter through the anodes 204a of the REP fuel cells 204. The cathodes 204b may receive hot gas, such as air, supplied to the system and a CO<sub>2</sub> and O<sub>2</sub> gas mixture produced in purification operation from the anode 204a of the REP fuel cell. In one illustrative embodiment, the fuel cell stack 200 of the REP system 100 incorporates components developed for commercial molten carbonate fuel cell technology, such as MCFC/DFC® developed by Fuel Cell Energy, Inc. However, it is understood that other types of molten carbonate fuel cells may be used in the REP system 100.

**[0059]** As also shown in FIG. 2, the REP system 100 may include one or more pre-heaters which utilize waste heat from the cells 204 of the REP system 100 and/or produced by other devices external to the REP system 100 and/or integrated with the REP system 100. The pre-heater 102 uses waste heat from the fuel cells 204 and reforming only cells 202 to preheat fuel, which may be mixed with water or humidified, prior to supplying the fuel to the reforming only cells 202. Other pre-heater(s) 104 may be used for pre-heating gas supplied to the system using waste heat from other devices such as a high temperature fuel cell being used to produce power. Moreover, as shown in FIG. 2, an oxidizer 106 may be provided for increasing the heat to the REP system 100 using supplemental fuel by oxidizing the supplemental fuel with air and generating hot oxidant gas which is then supplied to the REP fuel cell cathodes 204b.

**[0060]** The REP fuel cell stack 200 may be operated in purification mode, or a hydrogen-producing mode, as a purifying-reforming-electrolyzer and during such operation, removes almost all of the carbon from the system as CO<sub>3</sub><sup>-</sup> and produces nearly pure hydrogen from the reformed methane. In addition, the REP fuel cell stack 200 also efficiently produces additional hydrogen by dissociation of steam (electrolysis) at the same time. Thus, when natural gas is supplied to the REP system, about 80% of the hydrogen output is produced from the natural gas reformation and the other 20% of the hydrogen is provided by the electrolysis reaction. This REP system 100 produces hydrogen efficiently and with minimal CO<sub>2</sub> emissions.

**[0061]** As seen in FIG. 2, fuel, such as natural gas and/or renewable fuel, plus water are fed into the REP system 200. This fuel feed is heated in the pre-heater 102 and then routed to the reforming cells 202 and the REP fuel cells 204 where the almost all of the gas is reformed to hydrogen and CO. Heat for this endothermic reforming reaction may be provided, at least in part, by external waste heat 104, which is provided from other waste heat-generating devices. In certain embodiments, supplemental or extra fuel may be used as a backup or to raise the level of the waste heat, particularly when interruptible renewable waste heat such as wind power or solar heat is used as the source of waste heat. For example, in FIG. 2, an oxidizer 106 is provided in the system which receives supplemental fuel and air and oxidizes the supplemental fuel to produce heated gas for use in the cathode. In this way, the oxidizing reaction raises the level of waste heat that is used in the REP cells.

**[0062]** In the illustrative embodiment shown in FIG. 2, first the fuel gas is partially reformed in the reforming only cells (reformers) 202. The reaction occurring between water and methane in the reformer 202 is shown in FIG. 3. As shown in FIGS. 2 and 3, the partially-reformed gas from the reformer 202 is then fed to the anode side 204a of an MCFC fuel cell 204 operating in purification mode as an electrolyzer (REP cells) (hydrogen producing mode). In the fuel cells 204, water is dissociated to hydrogen and oxygen, the oxygen combines with the carbon dioxide in the reformed gas to produce  $\text{CO}_3^-$ , and the  $\text{CO}_3^-$  is removed electrochemically across the molten carbonate membrane. These reactions in the anode side 204a of the fuel cell 204 are shown in FIG. 3. This operation in the fuel cell 204 removes almost all of the carbon in the system and forces the equilibrium reforming and shift reactions to essentially complete conversion of the  $\text{CH}_4$  and CO to hydrogen. Thus, as shown in FIGS. 2 and 3, the exiting hydrogen-containing gas stream is almost pure hydrogen (greater than 98%) with a small amount of  $\text{CO}_2$  and  $\text{CH}_4$ . This small amount of  $\text{CO}_2$  and  $\text{CH}_4$  can easily be removed as the hydrogen is pressurized for systems requiring high purity hydrogen. However, many systems are able to use the low purity hydrogen directly, without the need for removing the small amount of impurities.

**[0063]** As shown in FIG. 2, the operation of the REP fuel cell 204 as an electrolyzer may be controlled by a controller. The controller 250 is programmed to control the supply or flow rate of reactant gases to the REP fuel cell 204. The controller 250 also controls the voltage and current applied to the fuel cell, which is supplied from the power supply (e.g., DC power supply)

230 so that the ion transfer is in the reverse direction of the normal fuel cell operation. The reactions that occur in the fuel cells of the REP system 100 are shown in FIG. 3. When a gas containing CO<sub>2</sub> and oxygen is used as the cathode side gas, the controller 250 may further control the switching of the operation modes of the fuel cell 204 between operation as an electrolyzer and normal power production operation.

**[0064]** Moreover, although the reforming cells 202 in FIG. 2 are shown as part of the REP fuel cell stack, so that the stack is an indirect internally reforming stack, in other embodiments, an external reformer may be used instead of or in addition to the internal reforming cells for reforming the fuel.

**[0065]** In certain illustrative embodiments, the components used in the REP system 200 of FIG. 2 are the same or similar to the commercially available components of DFC® fuel cells developed by FuelCell Energy, Inc. By using commercially available components for the REP system, this invention can be rapidly commercialized with competitive costs, which results in further cost savings.

**[0066]** Referring to FIG. 4, an alternative hydrogen and/or carbon monoxide production system is provided for converting natural gas and water to purified hydrogen and carbon monoxide, from which syngas may be formed. Conventionally, syngas is produced by steam methane reforming or by partial oxidation of a hydrocarbon using pure O<sub>2</sub> from an air separation unit. Syngas from steam methane reforming generally has a higher H<sub>2</sub> to CO ratio than desired and syngas from partial oxidation is not cost effective, except on a very large scale.

**[0067]** Certain embodiments of the present invention overcome these difficulties by using a hydrogen and/or carbon monoxide production system 400 with partial oxidation to generate hydrogen and/or carbon monoxide. Thereafter, hydrogen and carbon monoxide may be mixed to form syngas with a desired H<sub>2</sub>/CO ratio. The hydrogen and/or carbon monoxide production system 400 includes a heat source 410, a REP assembly 420, a reformer 412 for reforming a fuel feed and a partial oxidizer 430. The REP assembly 420 includes a REP anode 422 and a REP cathode 424.

**[0068]** As shown in FIG. 4, fuel is fed from a fuel supply, desulfurized, and preheated. Water may be added to the fuel before (not shown) or after preheating. Preferably, the fuel is natural gas or other suitable fuel. At least some of the fuel is fed to a partial oxidizer (i.e., oxidizer)

430. Water is converted to steam and mixed with the remaining desulfurized fuel to form a fuel and steam mixture. The fuel and steam mixture is fed through a secondary heat exchanger 414 and a reformer 412. At least some of the fuel and steam mixture is fed to the REP anode 422, and the remaining fuel and steam mixture is fed to the partial oxidizer 430.

**[0069]** The REP anode 422 receives the fuel and steam mixture, which reacts during electrolysis to produce an output gas from the REP anode containing mainly H<sub>2</sub>. The output gas from the REP anode 422 may be captured and stored or exported. During electrolysis, a stream of at least CO<sub>2</sub> and O<sub>2</sub> is output from the REP cathode 424 and fed to the partial oxidizer 430.

**[0070]** The partial oxidizer 430 receives and partially oxidizes fuel and the fuel and steam mixture with CO<sub>2</sub> and O<sub>2</sub>. The CO<sub>2</sub> and O<sub>2</sub> partially oxidize CH<sub>4</sub> from fuel from the fuel supply and the fuel and steam mixture to generate a mixture of CO, H<sub>2</sub>, and CO<sub>2</sub> (“syngas”). Preferably, the syngas has a high content of CO. The partial oxidation reaction performed in the partial oxidizer 430 is shown as follows:



Secondary reactions include a steam reforming reaction (*see* equation (2)), a CO<sub>2</sub> reforming reaction (*see* equation (3)), and a water-gas shift reaction (*see* equation (4)).

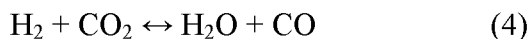
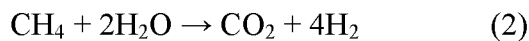

The syngas is fed from the partial oxidizer 430 through the reformer 412 to provide heat to that system and cool the syngas. The syngas may then be further cooled (not shown), captured, and stored or exported.

**[0071]** A heat source 410 combusts air and fuel to generate high-temperature exhaust. Preferably, the heat source is a fired heater, combustion turbine, internal combustion engine, or other suitable heat source. The high-temperature exhaust is fed through the reformer 412. Heat is transferred in the reformer 412 from the high-temperature exhaust to the feed gas (CH<sub>4</sub> + H<sub>2</sub>O) to partially reform the feed gas. The high-temperature exhaust is further fed through the

secondary heat exchanger 414 and vented out of the hydrogen and/or carbon monoxide production system 400. Heat is transferred in the secondary heat exchanger 414 from the high-temperature exhaust to the fuel and steam mixture to preheat the fuel and steam mixture before introduction to the reformer 412 and the REP anode 422.

**[0072]** Referring to FIG. 5, an alternative hydrogen and/or carbon monoxide production system 500 is provided for converting natural gas and water to purified hydrogen and carbon monoxide. The hydrogen and/or carbon monoxide production system 500 includes a heat source 510 and a REP assembly 520. The REP assembly 520 includes a REP anode 522, a REP cathode 524, and at least one reforming cell 526.

**[0073]** As shown in FIG. 5, fuel is first desulfurized, and preheated. Water may be added to the fuel before (not shown) or after preheating. Preferably, the fuel is natural gas or other suitable fuel. At least a portion of the fuel may be fed directly to the REP cathode 524 along with reformed fuel. Water is converted to steam and mixed with the remaining desulfurized fuel to form a fuel and steam mixture. The fuel and steam mixture is fed through a heat exchanger 514 and a pre-reformer 515, where slight reforming of the feed gas occurs, and to the reforming cells 526.

**[0074]** The reforming cells 526 receive the fuel and steam mixture. Heat from the oxidation reaction in the REP cathode 524 is removed by the reforming cells 526 and used in the reforming reaction, which includes a steam reforming reaction (*see* equation (5)), a CO<sub>2</sub> reforming reaction (*see* equation (6)), and a water-gas shift reaction (*see* equation (7)).

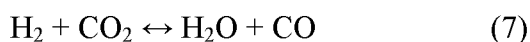
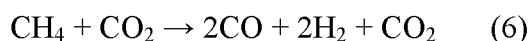
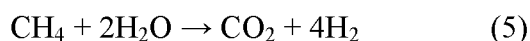

At least some of the output stream from the reforming cells 526 is fed to the REP anode 522, and the remaining output stream is fed to the REP cathode 524. In the REP anode 522, the output stream from the reforming cells 526 reacts during electrolysis to produce an output gas containing mainly H<sub>2</sub>. The output gas from the REP anode 522 may be captured and stored or exported. During electrolysis, a stream of at least CO<sub>2</sub> and O<sub>2</sub> is output from the REP cathode 524. The REP cathode 524 includes a partial oxidation catalyst. The REP cathode 524 receives

and partially oxidizes the output stream from the reforming cells 526 in this configuration, with CO<sub>2</sub> and O<sub>2</sub> to generate syngas. Preferably, the syngas has a high content of CO (i.e., is primarily CO). The partial oxidation reaction performed in the REP cathode 524 is shown as follows:

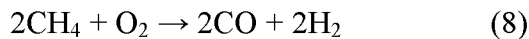

Secondary reactions include a steam reforming reaction (*see* equation (9)), a reforming reaction (*see* equation (10)), and a water-gas shift reaction (*see* equation (11)).

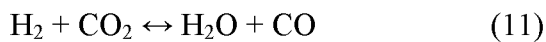
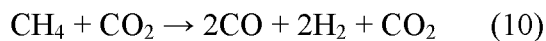
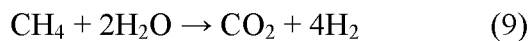

The syngas may then be captured and stored or exported. The configuration shown in FIG. 5 has the advantage of eliminating the need for a separate partial oxidation reaction, but since this partial oxidation reaction operates at a lower temperature, it will produce a syngas with lower CO to H<sub>2</sub> ratio than that produced in the illustrative embodiment in FIG. 4.

**[0075]** A heat source 510 combusts air and fuel to generate a high temperature exhaust. Preferably, the heat source is a fired heater, combustion turbine, internal combustion engine, or other suitable heat source. The exhaust is fed through the heat exchanger 514. Heat is transferred in the heat exchanger 514 from the exhaust to the fuel and steam mixture to preheat the fuel and steam mixture before introduction to the reforming cells 526. Further, an air supply heat exchanger (not shown) may transfer heat from the heat source to preheat air before introduction to the heat source.

**[0076]** Referring to FIG. 6, an alternative hydrogen production system 600 is provided for converting high-sulfur liquid fuel and water to purified hydrogen. Access to natural gas for operating a fuel cell may be limited in remote locations, but more widely-available fuels, such as those that are high in sulfur (e.g., diesel) may not always be used in place of natural gas when operating a fuel cell that is intolerant of sulfur.

[0077] Certain embodiments of the present invention overcome these difficulties by using a hydrogen production system 600 with partial oxidation to generate syngas, removing the sulfur after partial oxidation but before introducing the fuel to the fuel cell. The sulfur-free syngas is then converted to hydrogen in the REP assembly 620. The hydrogen production system 600 includes a high level heater (i.e., heater) 610, a REP assembly 620, and a partial oxidizer (i.e., oxidizer) 630. The REP assembly 620 includes a REP anode 622 and a REP cathode 624.

[0078] As shown in FIG. 6, water is converted to steam and mixed with fuel to form a fuel and steam mixture. Preferably, the fuel is diesel, JP8 or other low-cost suitable fuel. The fuel and steam mixture is fed to a low level preheater 616, through a high level heater 610, and then to the partial oxidizer 630.

[0079] The partial oxidizer 630 receives and partially oxidizes the fuel and steam mixture with  $\text{CO}_2$  and  $\text{O}_2$  generated in the REP cathode 624. The partial oxidation of the fuel and steam mixture converts the sulfur compounds in the feed to  $\text{H}_2\text{S}$  and  $\text{COS}$  in the syngas.  $\text{H}_2\text{S}$  and  $\text{COS}$  can be removed from the syngas. The partial oxidation reaction performed in the partial oxidizer 630 is shown as follows:

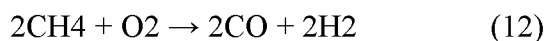

Secondary reactions include a steam reforming reaction (*see* equation (13)) and a reforming reaction (*see* equation (14)).

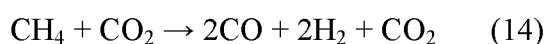
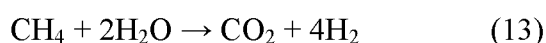

At least some of the syngas mixture is desulfurized, wherein the  $\text{H}_2\text{S}$  and  $\text{COS}$  is removed from the mixture, and is fed to the REP anode 622. The remaining  $\text{H}_2\text{S}$ ,  $\text{COS}$ , and syngas mixture that is not desulfurized is fed to the high level heater 610. According to an exemplary embodiment, desulfurized syngas may also be sent to the heater 610. In either configuration, the stream to the high level heater 610 also prevents  $\text{CO}_2$  from building up in the hydrogen production system 600.

[0080] The REP anode 622 receives the syngas, which reacts during electrolysis to produce an output gas containing mainly  $\text{H}_2$ . The output gas from the REP anode 622 may then be captured

and stored or exported. During electrolysis, a stream of at least CO<sub>2</sub> and O<sub>2</sub> is output from the REP cathode 624 and fed to the partial oxidizer 630.

**[0081]** The remaining H<sub>2</sub>S, COS, and syngas mixture that is not fed to the REP anode 622 is fed to the high level heater 610. The high level heater 610 combusts air with the H<sub>2</sub>S, COS, and syngas mixture to generate heat. Heat generated by the combustion in the high level heater 610 is transferred to the fuel and steam mixture. Exhaust generated by the high level heater 610 is vented out of the hydrogen production 600, which prevents the buildup of CO<sub>2</sub> within the hydrogen production system 600.

**[0082]** As utilized herein, the terms “approximately,” “about,” “substantially,” and similar terms are intended to have a broad meaning in harmony with the common and accepted usage by those of ordinary skill in the art to which the subject matter of this disclosure pertains. It should be understood by those of skill in the art who review this disclosure that these terms are intended to allow a description of certain features described and claimed without restricting the scope of these features to the precise numerical ranges provided. Accordingly, these terms should be interpreted as indicating that insubstantial or inconsequential modifications or alterations of the subject matter described and claimed are considered to be within the scope of this disclosure as recited in the appended claims.

**[0083]** It should be noted that the term “exemplary” as used herein to describe various embodiments is intended to indicate that such embodiments are possible examples, representations, and/or illustrations of possible embodiments (and such term is not intended to connote that such embodiments are necessarily extraordinary or superlative examples).

**[0084]** The terms “coupled,” “connected,” and the like as used herein mean the joining of two members directly or indirectly to one another. Such joining may be stationary (e.g., permanent) or moveable (e.g., removable or releasable). Such joining may be achieved with the two members or the two members and any additional intermediate members being integrally formed as a single unitary body with one another or with the two members or the two members and any additional intermediate members being attached to one another.

**[0085]** References herein to the position of elements (e.g., “top,” “bottom,” “above,” “below,” etc.) are merely used to describe the orientation of various elements in the FIGURES. It should

be noted that the orientation of various elements may differ according to other exemplary embodiments, and that such variations are intended to be encompassed by the present disclosure.

**[0086]** It is to be understood that although the present invention has been described with regard to preferred embodiments thereof, various other embodiments and variants may occur to those skilled in the art, which are within the scope and spirit of the invention, and such other embodiments and variants are intended to be covered by corresponding claims. Those skilled in the art will readily appreciate that many modifications are possible (e.g., structures, values of parameters, mounting arrangements, orientations, etc.) without materially departing from the novel teachings and advantages of the subject matter described herein. For example, the order or sequence of any process or method steps may be varied or re-sequenced according to alternative embodiments. Other substitutions, modifications, changes and omissions may also be made in the design, operating conditions and arrangement of the various exemplary embodiments without departing from the scope of the present disclosure.

**WHAT IS BEING CLAIMED IS:**

1. A system for producing at least one of hydrogen or carbon monoxide, comprising:
  - at least one fuel cell comprising:
    - an anode and a cathode separated by an electrolyte matrix; and
    - a power supply for applying a reverse voltage to the at least one fuel cell to operate the fuel cell in reverse as an electrolyzer;
    - wherein the anode is configured to receive a partially-reformed fuel and output a gas comprising hydrogen;
    - wherein the cathode is configured to output a gas comprising carbon dioxide and oxygen; and
    - at least one oxidizer configured to receive the carbon dioxide and oxygen from the cathode and fuel from a fuel supply, the at least one oxidizer configured to output a partially-oxidized fuel comprising carbon monoxide, carbon dioxide, and hydrogen.
2. The system according to claim 1, further comprising a heat source configured to generate heat and exhaust.
3. The system according to claim 2, wherein the heat source is a fired heater.
4. The system according to claims 2, further comprising a reformer configured to receive fuel from the fuel supply and at least one of steam or water.
5. The system according to claim 4, wherein the reformer is configured to transfer heat from the heat source to the fuel and to the at least one of steam or water; and
  - wherein the reformer is configured to at least partially reform the fuel and at least one of steam or water.
6. The system according to claim 4, further comprising a pre-heater configured to pre-heat the fuel before the fuel is received in the reformer.
7. The system according to claim 6, wherein the pre-heater is configured to pre-heat the fuel using waste heat.

8. The system according to claim 2, further comprising an air supply heat exchanger configured to transfer heat generated by the heat source to air received by the heat source.

9. The system according to any of claim 2, wherein the heat source is configured to vent exhaust out of the system.

10. A method of generating at least one of hydrogen or carbon monoxide using the system according to any of claims 2-9, the method comprising:

receiving, at the anode of the fuel cell, partially-reformed fuel and at least one of steam or water, and outputting hydrogen from the anode of the fuel cell;

outputting carbon dioxide and oxygen from the cathode of the fuel cell;

receiving, at the at least one oxidizer, carbon dioxide and oxygen from the cathode and fuel from the fuel source; and

outputting carbon monoxide from the at least one oxidizer.

11. The method according to claim 10, further comprising venting exhaust generated by the heat source after heat is transferred from the exhaust by at least one of a reformer or a heat exchanger.

12. The method according to claim 10, further comprising transferring heat from exhaust generated by the heat source to the fuel in at least one of a reformer or a heat exchanger.

13. The method according to claim 10, further comprising transferring heat from exhaust generated by the heat source to at least one of steam or water in at least one of a reformer or a heat exchanger.

14. The method according to claim 10, further comprising mixing hydrogen output from the anode of the fuel cell and carbon monoxide output from the at least one oxidizer to form a syngas.

15. The method according to claim 10, further comprising desulfurizing the fuel prior to feeding the fuel to a reformer.

16. A system for producing at least one of hydrogen or carbon monoxide, comprising:

at least one fuel cell comprising:

an anode and a cathode separated by an electrolyte matrix;  
a power supply for applying a reverse voltage to the at least one fuel cell to operate the fuel cell in reverse as an electrolyzer; and  
a reforming cell configured to receive fuel from a fuel supply and at least one of steam or water, the reforming cell configured to output a partially-reformed fuel;  
wherein the reforming cell is configured to feed the partially-reformed fuel to the anode and the cathode;  
wherein the anode is configured to receive the partially-reformed fuel and output a gas comprising hydrogen;  
wherein the cathode is configured to receive and at least partially oxidize at least one of the fuel from the fuel supply or the partially-reformed fuel; and  
wherein the cathode is configured to output carbon monoxide, hydrogen, and carbon dioxide.

17. The system according to claim 16, wherein the cathode further comprises a catalyst configured to partially oxidize the partially-reformed fuel.

18. The system according to claim 16, wherein the cathode is configured to output primarily carbon monoxide.

19. The system according to claim 16, further comprising a heat source configured to generate heat and exhaust.

20. The system according to claim 19, further comprising a first heat exchanger configured to transfer heat from the heat source to fuel from the fuel supply and at least one of steam or water.

21. The system according to claim 19, wherein the heat source is a fired heater.

22. The system according to claim 19, wherein the heat source is configured to vent exhaust out of the system.

23. The system according to claim 16, further comprising a pre-reformer configured to receive fuel from the fuel supply and at least one of steam or water.

24. The system according to any of claims 16, further comprising a pre-heater configured to pre-heat the fuel before the fuel is received in the reforming cell.

25. The system according to claim 24, wherein the pre-heater is configured to pre-heat the fuel using waste heat.

26. The system according to claim 16, wherein the fuel from the fuel supply is methane.

27. A method of generating at least one of hydrogen or carbon monoxide with the system according to any of claims 16-26, the method comprising:

receiving, at the reforming cell, methane and steam, and outputting a partially-reformed fuel from the reforming cell;

receiving, at the anode, the partially-reformed fuel from the reforming cell, and outputting hydrogen from the anode;

receiving, at the cathode, the partially-reformed fuel from the reforming cell, and outputting at least carbon monoxide from the cathode; and

receiving, at the cathode, fuel from the fuel supply and at least one of steam or water.

28. The method according to claim 27, further comprising using a reforming reaction in the reforming cell to remove at least a portion of heat generated in an oxidation reaction in the cathode.

29. The method according to claim 27, further comprising desulfurizing fuel from the fuel supply prior to feeding the fuel to the reforming cell.

30. The method according to claim 27, further comprising mixing hydrogen output from the anode of the fuel cell and carbon monoxide output from the cathode of the fuel cell to form a syngas.

31. A system for producing hydrogen, comprising:

at least one fuel cell comprising:

an anode and a cathode separated by an electrolyte matrix; and

a power supply for applying a reverse voltage to the at least one fuel cell to operate the fuel cell in reverse as an electrolyzer;

an oxidizer configured to receive fuel from a fuel supply and at least one of steam or water, the oxidizer configured to output a partially-reformed fuel;

wherein the anode is configured to receive the partially-reformed fuel from the oxidizer and to output hydrogen; and

wherein the cathode is configured to output carbon dioxide and oxygen to the oxidizer.

32. The system according to claim 31, further comprising a heater configured to heat the fuel and at least one of steam or water.

33. The system according to claim 32, wherein the heater is configured to receive a portion of the partially-reformed fuel output by the oxidizer.

34. The system according to claim 33, wherein the heater is configured to combust the partially-reformed fuel to generate heat.

35. The system according to claim 34, wherein the heater is configured to vent exhaust out of the system.

36. The system according to claim 31, wherein the fuel is diesel fuel or JP8.

37. The system according to claim 32, further comprising a pre-heater configured to pre-heat the fuel and the at least one of steam or water before the fuel and the at least one of steam or water are received in the heater.

38. The system according to claim 37, wherein the pre-heater is configured to pre-heat the fuel using waste heat.

39. A method of generating hydrogen with the system according to any of claims 31-38, the method comprising:

receiving, at the oxidizer, fuel and steam, and outputting partially-oxidized fuel from the oxidizer;

receiving, at the anode, the partially-oxidized fuel, and outputting hydrogen from the anode;

outputting carbon dioxide and oxygen from the cathode; and

receiving, at the oxidizer, carbon dioxide and oxygen from the cathode.

40. The method according to claim 39, further comprising oxidizing fuel and steam from the heater with the carbon dioxide and oxygen output from the cathode.
41. The method according to claim 39, further comprising desulfurizing the partially-oxidized fuel prior to feeding the partially-oxidized fuel to the anode.
42. The method according to claim 39, further comprising feeding a portion of the partially-oxidized fuel from the oxidizer to a heater configured to heat the fuel and at least one of steam or water.
43. The method according to any of claims 42, further comprising desulfurizing the portion of the partially-oxidized fuel before it is received by the heater.
44. The method according to claim 42, further comprising combusting the portion of the partially-oxidized fuel to generate heat in the heater.
45. The method according to claim 39, further comprising venting exhaust generated by the heater out of the system.

## AMENDED CLAIMS

received by the International Bureau on 21 March 2017 (21.03.2017)

**WHAT IS CLAIMED IS:**

1. A system for producing at least one of hydrogen or carbon monoxide, comprising:
  - at least one fuel cell comprising:
    - an anode and a cathode separated by an electrolyte matrix; and
    - a power supply for applying a reverse voltage to the at least one fuel cell to operate the fuel cell in reverse as an electrolyzer;
    - wherein the anode is configured to receive a partially-reformed fuel and output a gas comprising hydrogen;
    - wherein the cathode is configured to output a gas comprising carbon dioxide and oxygen; and
    - at least one oxidizer configured to receive the carbon dioxide and oxygen from the cathode and fuel from a fuel supply, the at least one oxidizer configured to output a partially-oxidized fuel comprising carbon monoxide, carbon dioxide, and hydrogen.
2. The system according to claim 1, further comprising a heat source configured to generate heat and exhaust.
3. The system according to claim 2, wherein the heat source is a fired heater.
4. The system according to claim 2, further comprising a reformer configured to receive fuel from the fuel supply and at least one of steam or water.
5. The system according to claim 4, wherein the reformer is configured to transfer heat from the heat source to the fuel and to the at least one of steam or water; and
  - wherein the reformer is configured to at least partially reform the fuel and at least one of steam or water.
6. The system according to claim 4, further comprising a pre-heater configured to pre-heat the fuel before the fuel is received in the reformer.
7. The system according to claim 6, wherein the pre-heater is configured to pre-heat the fuel using waste heat.

8. The system according to claim 2, further comprising an air supply heat exchanger configured to transfer heat generated by the heat source to air received by the heat source.
9. The system according to claim 2, wherein the heat source is configured to vent exhaust out of the system.
10. A method of generating at least one of hydrogen or carbon monoxide using the system according to any of claims 2-9, the method comprising:
  - receiving, at the anode of the fuel cell, partially-reformed fuel and at least one of steam or water, and outputting hydrogen from the anode of the fuel cell;
  - outputting carbon dioxide and oxygen from the cathode of the fuel cell;
  - receiving, at the at least one oxidizer, carbon dioxide and oxygen from the cathode and fuel from the fuel source; and
  - outputting carbon monoxide from the at least one oxidizer.
11. The method according to claim 10, further comprising venting exhaust generated by the heat source after heat is transferred from the exhaust by at least one of a reformer or a heat exchanger.
12. The method according to claim 10, further comprising transferring heat from exhaust generated by the heat source to the fuel in at least one of a reformer or a heat exchanger.
13. The method according to claim 10, further comprising transferring heat from exhaust generated by the heat source to at least one of steam or water in at least one of a reformer or a heat exchanger.
14. The method according to claim 10, further comprising mixing hydrogen output from the anode of the fuel cell and carbon monoxide output from the at least one oxidizer to form a syngas.
15. The method according to claim 10, further comprising desulfurizing the fuel prior to feeding the fuel to a reformer.

16. A system for producing at least one of hydrogen or carbon monoxide, comprising:
- at least one fuel cell comprising:
    - an anode and a cathode separated by an electrolyte matrix;
    - a power supply for applying a reverse voltage to the at least one fuel cell to operate the fuel cell in reverse as an electrolyzer; and
    - a reforming cell configured to receive fuel from a fuel supply and at least one of steam or water, the reforming cell configured to output a partially-reformed fuel;
  - wherein the reforming cell is configured to feed the partially-reformed fuel to the anode and the cathode;
  - wherein the anode is configured to receive the partially-reformed fuel and output a gas comprising hydrogen;
  - wherein the cathode is configured to receive and at least partially oxidize at least one of the fuel from the fuel supply or the partially-reformed fuel; and
  - wherein the cathode is configured to output carbon monoxide, hydrogen, and carbon dioxide.
17. The system according to claim 16, wherein the cathode further comprises a catalyst configured to partially oxidize the partially-reformed fuel.
18. The system according to claim 16, wherein the cathode is configured to output primarily carbon monoxide.
19. The system according to claim 16, further comprising a heat source configured to generate heat and exhaust.
20. The system according to claim 19, further comprising a first heat exchanger configured to transfer heat from the heat source to fuel from the fuel supply and at least one of steam or water.
21. The system according to claim 19, wherein the heat source is a fired heater.
22. The system according to claim 19, wherein the heat source is configured to vent exhaust out of the system.

23. The system according to claim 16, further comprising a pre-reformer configured to receive fuel from the fuel supply and at least one of steam or water.
24. The system according to claim 16, further comprising a pre-heater configured to pre-heat the fuel before the fuel is received in the reforming cell.
25. The system according to claim 24, wherein the pre-heater is configured to pre-heat the fuel using waste heat.
26. The system according to claim 16, wherein the fuel from the fuel supply is methane.
27. A method of generating at least one of hydrogen or carbon monoxide with the system according to any of claims 16-26, the method comprising:
- receiving, at the reforming cell, methane and steam, and outputting a partially-reformed fuel from the reforming cell;
  - receiving, at the anode, the partially-reformed fuel from the reforming cell, and outputting hydrogen from the anode;
  - receiving, at the cathode, the partially-reformed fuel from the reforming cell, and outputting at least carbon monoxide from the cathode; and
  - receiving, at the cathode, fuel from the fuel supply and at least one of steam or water.
28. The method according to claim 27, further comprising using a reforming reaction in the reforming cell to remove at least a portion of heat generated in an oxidation reaction in the cathode.
29. The method according to claim 27, further comprising desulfurizing fuel from the fuel supply prior to feeding the fuel to the reforming cell.
30. The method according to claim 27, further comprising mixing hydrogen output from the anode of the fuel cell and carbon monoxide output from the cathode of the fuel cell to form a syngas.
31. A system for producing hydrogen, comprising:  
at least one fuel cell comprising:

an anode and a cathode separated by an electrolyte matrix; and

a power supply for applying a reverse voltage to the at least one fuel cell to operate the fuel cell in reverse as an electrolyzer;

an oxidizer configured to receive fuel from a fuel supply and at least one of steam or water, the oxidizer configured to output a partially-reformed fuel;

wherein the anode is configured to receive the partially-reformed fuel from the oxidizer and to output hydrogen; and

wherein the cathode is configured to output carbon dioxide and oxygen to the oxidizer.

32. The system according to claim 31, further comprising a heater configured to heat the fuel and at least one of steam or water.

33. The system according to claim 32, wherein the heater is configured to receive a portion of the partially-reformed fuel output by the oxidizer.

34. The system according to claim 33, wherein the heater is configured to combust the partially-reformed fuel to generate heat.

35. The system according to claim 34, wherein the heater is configured to vent exhaust out of the system.

36. The system according to claim 31, wherein the fuel is diesel fuel or JP8.

37. The system according to claim 32, further comprising a pre-heater configured to pre-heat the fuel and the at least one of steam or water before the fuel and the at least one of steam or water are received in the heater.

38. The system according to claim 37, wherein the pre-heater is configured to pre-heat the fuel using waste heat.

39. A method of generating hydrogen with the system according to any of claims 31-38, the method comprising:

receiving, at the oxidizer, fuel and steam, and outputting partially-oxidized fuel from the oxidizer;

receiving, at the anode, the partially-oxidized fuel, and outputting hydrogen from the anode;

outputting carbon dioxide and oxygen from the cathode; and  
receiving, at the oxidizer, carbon dioxide and oxygen from the cathode.

40. The method according to claim 39, further comprising oxidizing fuel and steam from the heater with the carbon dioxide and oxygen output from the cathode.

41. The method according to claim 39, further comprising desulfurizing the partially-oxidized fuel prior to feeding the partially-oxidized fuel to the anode.

42. The method according to claim 39, further comprising feeding a portion of the partially-oxidized fuel from the oxidizer to a heater configured to heat the fuel and at least one of steam or water.

43. The method according to claim 42, further comprising desulfurizing the portion of the partially-oxidized fuel before it is received by the heater.

44. The method according to claim 42, further comprising combusting the portion of the partially-oxidized fuel to generate heat in the heater.

45. The method according to claim 39, further comprising venting exhaust generated by the heater out of the system.

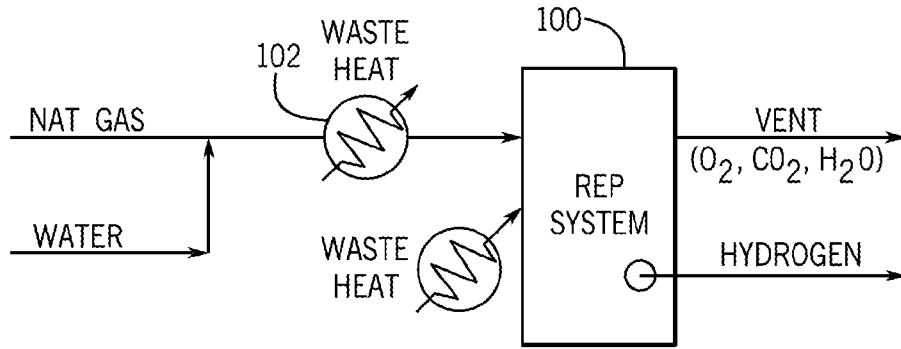

FIG. 1

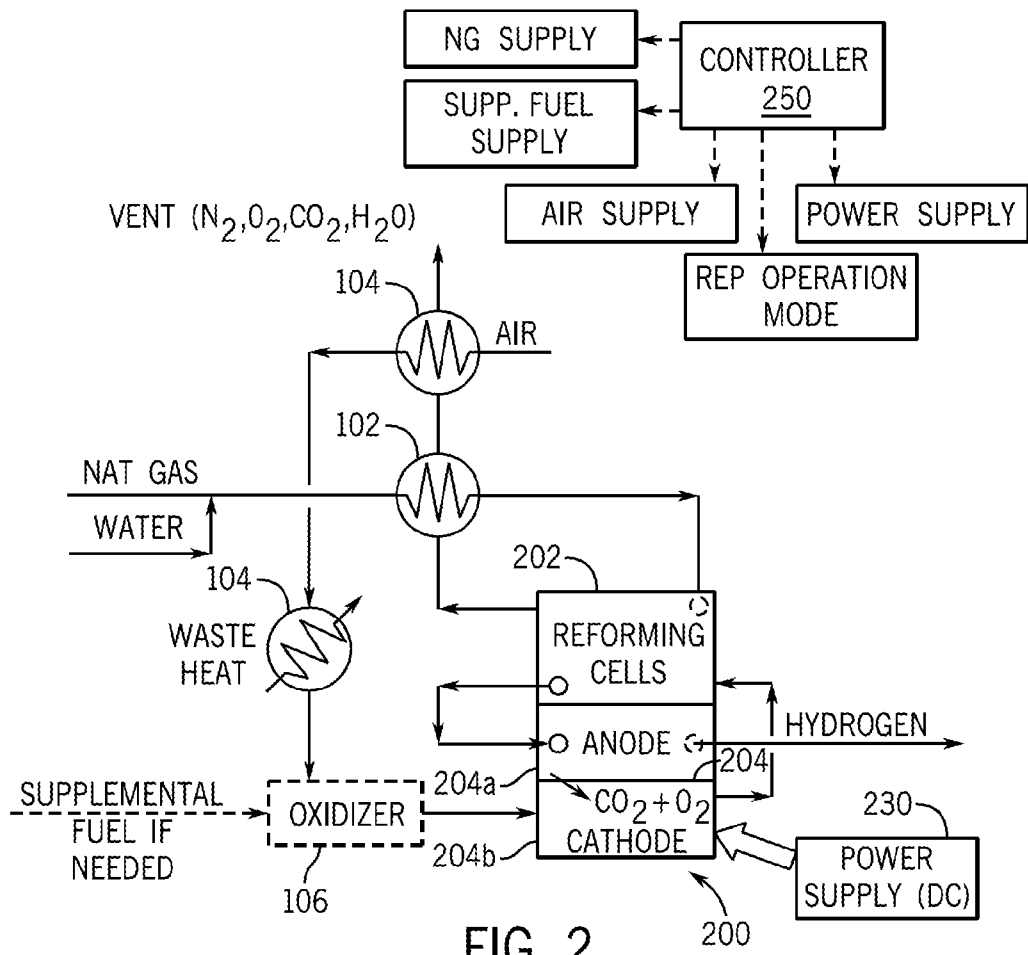

FIG. 2

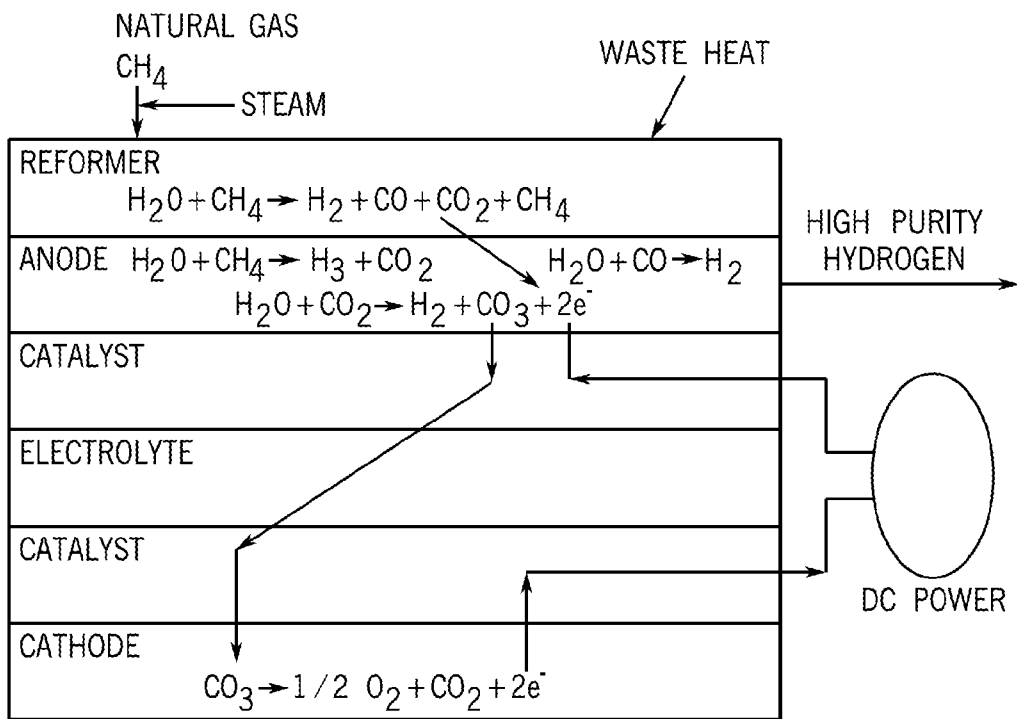

FIG. 3

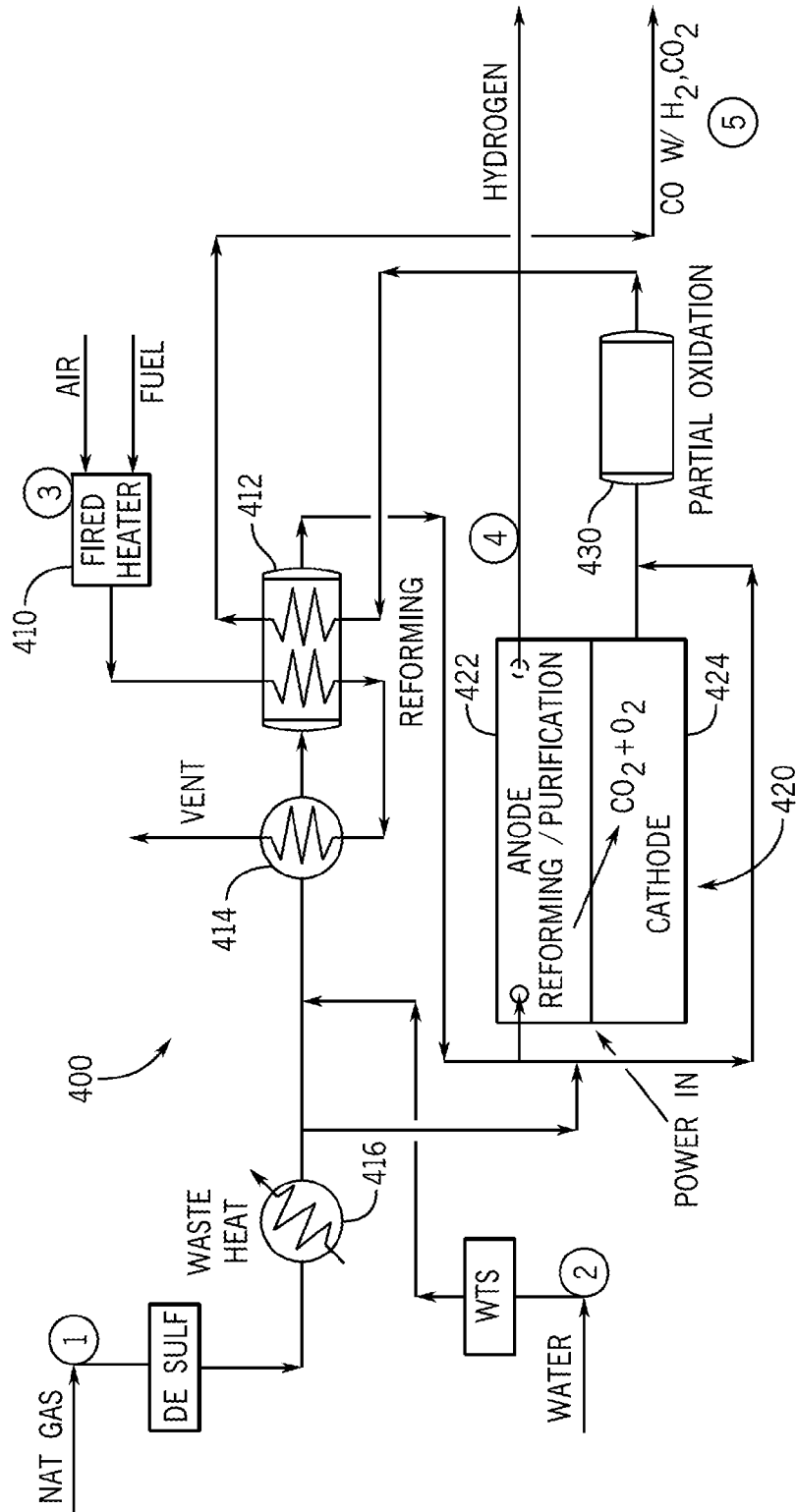

FIG. 4

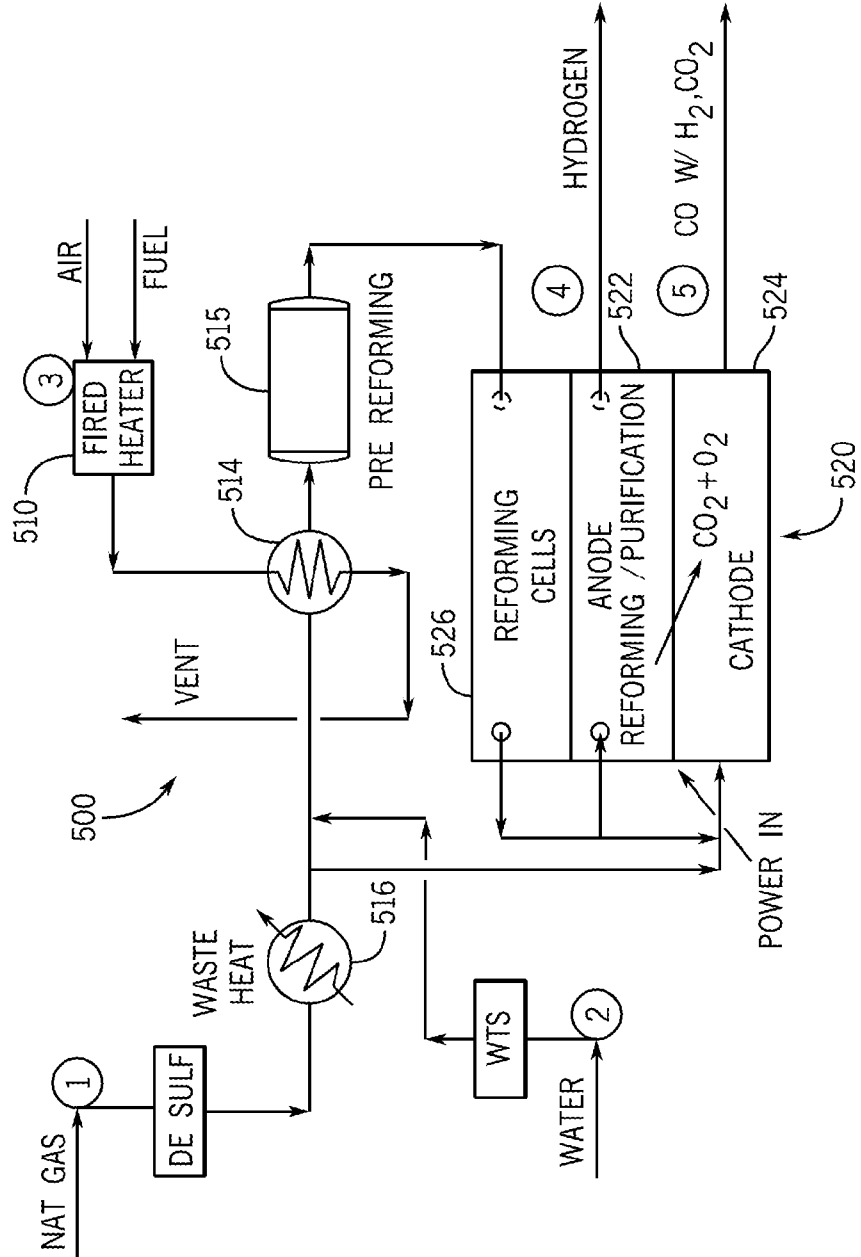

FIG. 5

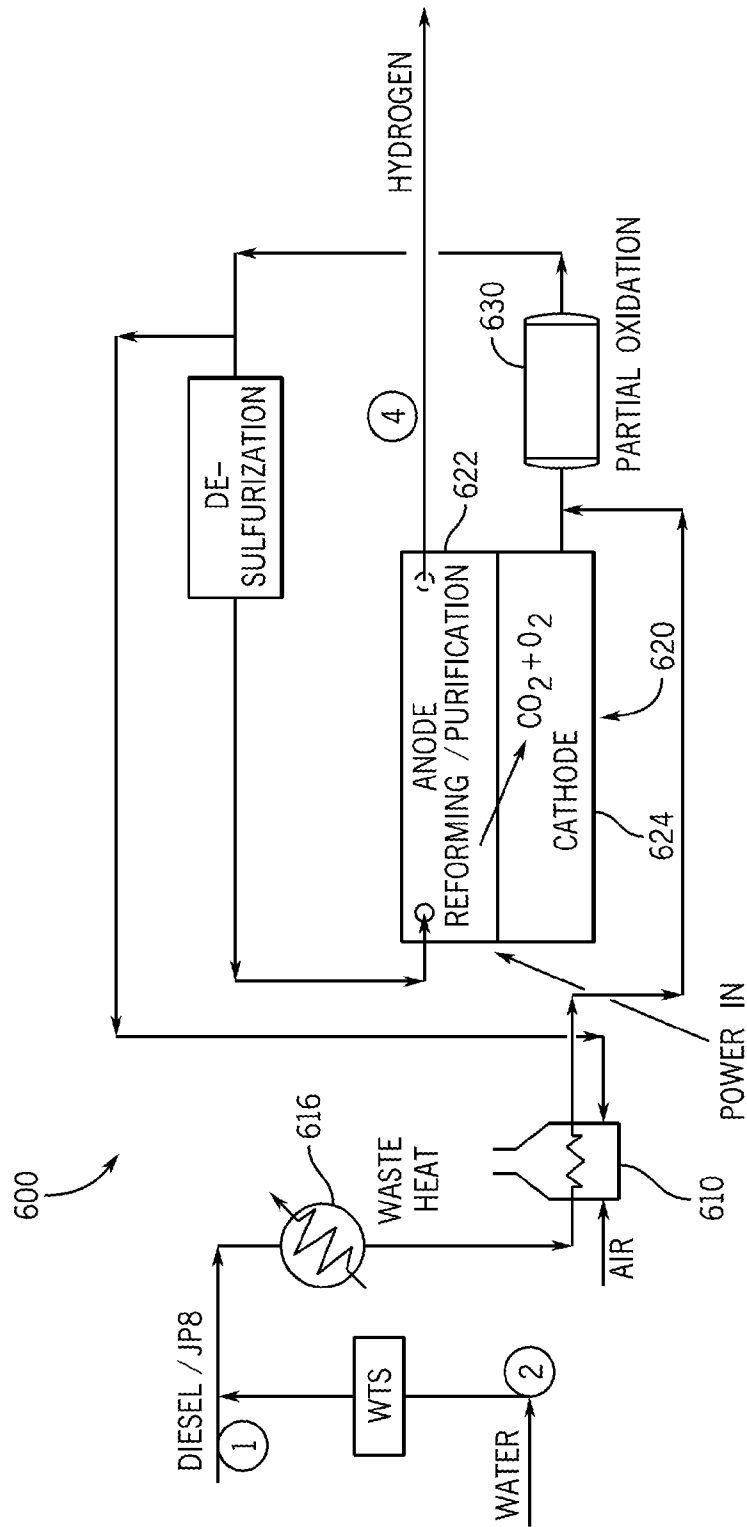

FIG. 6

## INTERNATIONAL SEARCH REPORT

International application No.

PCT/US16/62276

## A. CLASSIFICATION OF SUBJECT MATTER

IPC - C01B 3/02; C25B 1/00, 15/02; H01M 8/04007, 8/0612, 8/0656 (2017.01)

CPC - C01B 3/02, 3/12, 3/583; H01M 8/00, 8/04007, 8/04089, 8/04298, 8/04328, 8/0435, 8/04373, 8/04544, 8/0612, 8/0618, 8/0656, 8/22

According to International Patent Classification (IPC) or to both national classification and IPC

## B. FIELDS SEARCHED

Minimum documentation searched (classification system followed by classification symbols)

See Search History document

Documentation searched other than minimum documentation to the extent that such documents are included in the fields searched

See Search History document

Electronic data base consulted during the international search (name of data base and, where practicable, search terms used)

See Search History document

## C. DOCUMENTS CONSIDERED TO BE RELEVANT

Category*	Citation of document, with indication, where appropriate, of the relevant passages	Relevant to claim No.
A	WO 2015/116964 A1 (FUELCELL ENERGY, INC.) 06 August 2015; entire document	1-45
A	US 2005/0123810 A1 (BALAN, C.) 09 June 2005; entire document	1-45
A	US 2005/0112425 A1 (HSU, M. S.) 26 May 2005; entire document	1-45
A	US 2014/0093798 A1 (FUELCELL ENERGY, INC) 03 April 2014; entire document	1-45
A	WO 2013/029701 A1 (OSTEE MARITIME GMBH) 07 March 2013; entire document	1-45
A	US 2009/0226775 A1 (JAHNKE, F. C. et al.) 10 September 2009; entire document	1-45
A	US 2009/0110989 A1 (DALY, J. M. et al.) 30 April 2009; entire document	1-45

Further documents are listed in the continuation of Box C.

See patent family annex.

\* Special categories of cited documents:

"A" document defining the general state of the art which is not considered to be of particular relevance

"E" earlier application or patent but published on or after the international filing date

"L" document which may throw doubts on priority claim(s) or which is cited to establish the publication date of another citation or other special reason (as specified)

"O" document referring to an oral disclosure, use, exhibition or other means

"P" document published prior to the international filing date but later than the priority date claimed

"T" later document published after the international filing date or priority date and not in conflict with the application but cited to understand the principle or theory underlying the invention

"X" document of particular relevance; the claimed invention cannot be considered novel or cannot be considered to involve an inventive step when the document is taken alone

"Y" document of particular relevance; the claimed invention cannot be considered to involve an inventive step when the document is combined with one or more other such documents, such combination being obvious to a person skilled in the art

"&amp;" document member of the same patent family

Date of the actual completion of the international search

16 January 2017 (16.01.2017)

Date of mailing of the international search report

31 JAN 2017

Name and mailing address of the ISA/

Mail Stop PCT, Attn: ISA/US, Commissioner for Patents  
P.O. Box 1450, Alexandria, Virginia 22313-1450  
Facsimile No. 571-273-8300

Authorized officer

Shane Thomas

PCT Helpdesk: 571-272-4300  
PCT OSP: 571-272-7774