

S. Boyden.

Picker.

N^o 46,294.

Patented Feb. 7, 1865.

Fig. 1.

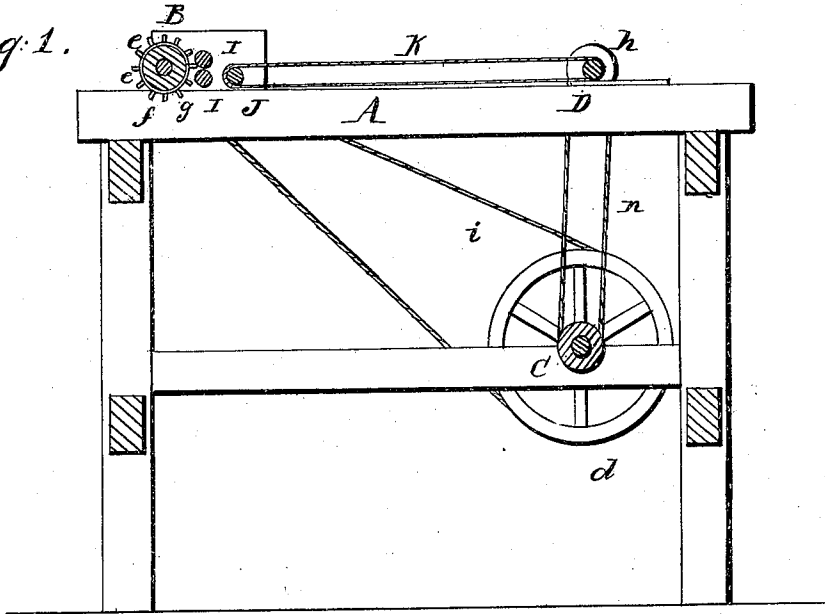
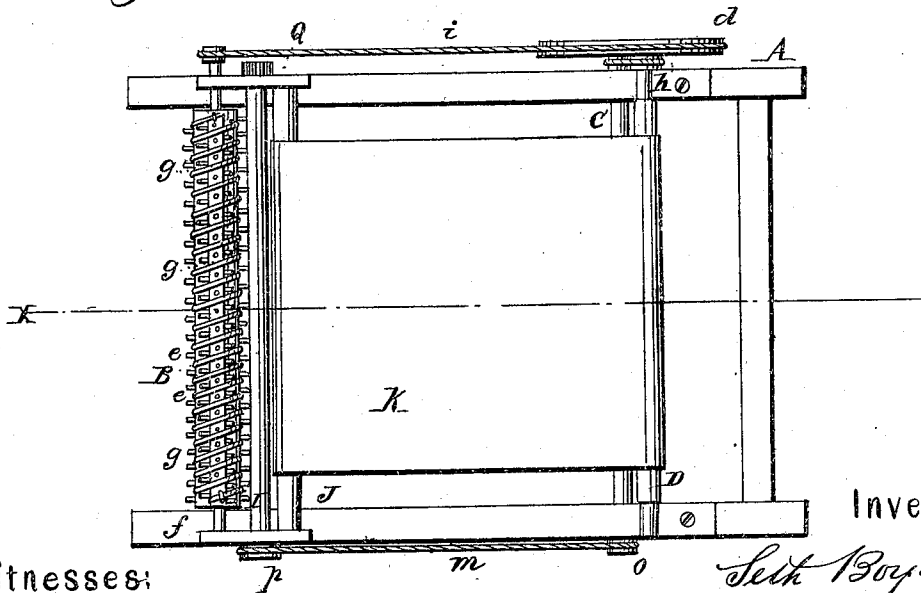

Fig. 2.



Witnesses:

*Wm Brown
Geo Tuck*

Inventor:

*Seth Boyden
Jno Munnell
Attorneys*

UNITED STATES PATENT OFFICE.

SETH BOYDEN, OF NEWARK, NEW JERSEY, ASSIGNOR TO HENRY H. JACQUES, OF SAME PLACE.

IMPROVEMENT IN PICKING-CYLINDERS OF MACHINES FOR DISINTEGRATING FIBROUS MATERIALS.

Specification forming part of Letters Patent No. 46,294, dated February 7, 1865.

To all whom it may concern:

Be it known that I, SETH BOYDEN, of Newark, in the county of Essex and State of New Jersey, have invented a new and useful Improvement in Pickers; and I do hereby declare that the following is a full, clear, and exact description thereof, which will enable others skilled in the art to make and use the same, reference being had to the accompanying drawings, forming part of this specification, in which—

Figure 1 is a sectional elevation of so much of a picker as is necessary to show my invention, taken on the line *x* of Fig. 2. Fig. 2 is a plan thereof.

Similar letters of reference indicate like parts.

This invention consists in binding the wooden picker-cylinders of pickers for disintegrating fibrous materials by means of a strand or strands of wire, or other equivalent means, so as to strengthen them and make it possible to run them with safety at a greater speed than has been possible hitherto.

A is the frame of the picker. C is its driving-shaft, provided at one end with a large pulley, *d*, a band from which drives the cylinder B, as usual. The other end of the shaft C has a small pulley, O, a band from which drives the upper one of two feed-rolls, I, which are geared together by gear-wheels Q on their opposite ends. The shaft C has on it another pulley, *h*, between the large pulley *d* and the adjacent side of the frame A, a band from which drives the apron-shaft D.

K is the endless apron of the picker carried by the shaft D and by a roller, J, placed near to the feed-rolls I, according to the construction generally adopted.

The cylinder B is made of wood, secured to a central metallic shaft, *f*, to which it is firmly secured. Its sides are set full of short spikes, as usual.

In disintegrating and separating the fibers of fur, wool, cotton, and other fibrous materials from each other it is necessary that the cylinder be driven at a very high speed in order that the fine bodies composing the material may be effectually separated, approaching sometimes a speed of five or six thousand revolutions in a minute. This is especially necessary in disintegrating fur and other stock for use in the manufacture of hats, and the high speed employed frequently causes the cylinder to fly to pieces by centrifugal action, endangering the operatives employed about the machine and causing great loss and damage to the machinery.

In order to strengthen the cylinder and make it possible to run it at a very high speed with safety, I bind it with suitable strengthening-bands, and in this example of my invention I have shown the cylinder bound around by a strand of wire, *g*, laid in a spiral direction between the rows of spikes, the ends of the wire being fastened in the body of the cylinder. One or more strands of wire, where wire is the means used, may be bound upon the cylinder, and they may be wound upon its unbroken surface, or shallow grooves may be cut thereon to receive them and allow them to be partially embedded therein. Cylinders of wood thus prepared may be run at a speed of ten thousand revolutions a minute with entire safety, and at a still higher speed, if desired.

I claim as new and desire to secure by Letters Patent—

Binding the picker-cylinders of pickers for disintegrating fibrous materials, as and for the purpose described.

SETH BOYDEN.

Witnesses:

WM. E. LAYTON,
WM. RANKIN.