

(19)



Europäisches Patentamt

European Patent Office

Office européen des brevets



(11)

EP 0 706 857 B1

(12)

EUROPEAN PATENT SPECIFICATION

(45) Date of publication and mention of the grant of the patent:

14.07.1999 Bulletin 1999/28

(51) Int. Cl.⁶: **B24B 37/04**, B24B 21/06

(21) Application number: **95307203.0**

(22) Date of filing: **11.10.1995**

(54) **Wafer polishing machine**

Vorrichtung zum Polieren eines Halbleiters

Machine de polissage pour plaquettes semi-conductrices

(84) Designated Contracting States:
AT BE CH DE DK ES FR GB GR IE IT LI LU MC NL PT SE

(30) Priority: **11.10.1994 US 321085**
02.11.1994 US 333463

(43) Date of publication of application:
17.04.1996 Bulletin 1996/16

(73) Proprietor: **ONTRAK SYSTEMS, INC.**
Milpitas, California 95035 (US)

(72) Inventors:
• **Talieh, Homayoun**
Santa Jose, California 95124 (US)
• **Weldon, David Edwin**
Los Gatos, California 95030 (US)
• **Nagorski, Boguslaw A.**
San Jose, California 95124 (US)

(74) Representative:
Bucks, Teresa Anne et al
BOULT WADE TENNANT,
27 Furnival Street
London EC4A 1PQ (GB)

(56) References cited:
DE-A- 3 411 120 **US-A- 5 246 525**

- **PATENT ABSTRACTS OF JAPAN vol. 015 no. 028 (M-1072) ,23 January 1991 & JP-A-02 269553 (RODEELE NITTA KK) 2 November 1990,**
- **PATENT ABSTRACTS OF JAPAN vol. 009 no. 111 (M-379) ,15 May 1985 & JP-A-59 232768 (KANEBO KK) 27 December 1984,**
- **PATENT ABSTRACTS OF JAPAN vol. 012 no. 478 (M-775) ,14 December 1988 & JP-A-63 200965 (FUJITSU LTD) 19 August 1988,**
- **PATENT ABSTRACTS OF JAPAN vol. 013 no. 041 (M-791) ,30 January 1989 & JP-A-63 251166 (HITACHI LTD) 18 October 1988,**

Note: Within nine months from the publication of the mention of the grant of the European patent, any person may give notice to the European Patent Office of opposition to the European patent granted. Notice of opposition shall be filed in a written reasoned statement. It shall not be deemed to have been filed until the opposition fee has been paid. (Art. 99(1) European Patent Convention).

EP 0 706 857 B1

Description

[0001] This invention relates to polishing machines for planarizing semi-conductor wafers, and in particular to such machines having improved bearings, and a method of use of the polishing machine.

[0002] Chemical mechanical polishing machines for semi-conductor wafers are well known in the art, as described for example in U.S. Patents 5,335,453, 5,329,732, 5,287,663, 5,297,361 and 4,811,522. Typically, such polishing machines utilize mechanical bearings for the polishing pad and the wafer holder. Such mechanical bearings can provide disadvantages in operation. Mechanical bearings can become contaminated with the abrasive slurry used in the polishing process. If mechanical bearings provide point or line support for a polishing pad platen, the possibility of cantilever bending of the platen arises. Bearing vibrations can result in undesirable noise, and bearing adjustment typically requires a mechanical adjustment of the assembly. This adjustment is typically a high-precision, time-consuming adjustment.

[0003] JP 2269553 describes a polishing machine in which a polishing belt is pressed against a workpiece by a pressurised fluid film. This is an example of a machine having the features of the preamble of claim 1.

[0004] It is an object of the present invention to provide a polishing machine having fluid bearings that to a large extent overcome the problems set out above, and that can easily be adjusted to control polishing forces.

[0005] This invention relates to semi-conductor wafer polishing machines of the type comprising at least one polishing pad assembly and at least one wafer holder positioned to hold a semi-conductor wafer against the polishing pad assembly and a method of adjusting a pressure profile in such a machine

[0006] According to this invention, there is provided a semi-conductor wafer polishing machine of the type comprising at least one polishing pad assembly and at least one wafer holder positioned to hold a semi-conductor wafer against the polishing pad assembly, and a support positioned adjacent the polishing pad assembly, characterised in that at least one of said support and said polishing pad assembly comprises a plurality of fluid bearings that support the polishing pad assembly on the support, each of said fluid bearings comprising:

a separate respective fluid supply conduit connectable to a respective source of fluid at a separate respective pressure;

a respective set of fluid pads, each in fluid communication with the respective fluid supply conduit, said fluid pads configured to direct fluid from the respective fluid supply conduit to support in part the polishing pad assembly on the support.

[0007] Preferably, at least some of the sets of fluid

pads are arranged in respective concentric rings. With this arrangement support forces for the polishing pad assembly can be varied across the face of the wafer being polished, thereby enhancing uniform polishing rates. A method of so doing is achieved by a method having the features of the attached claim 9.

[0008] The invention itself, together with further objects and attendant advantages, will best be understood by reference to the following detailed description, taken with the accompanying drawings, in which:

FIGURE 1 is a perspective view of a chemical mechanical wafer polishing machine.

FIGURE 2 is a perspective view of a belt support assembly included in the polishing machine of Figure 1.

Figure 3 is a top view of hydrostatic bearings included in the belt support assembly of Figure 2.

Figure 4 is a perspective view of portions of another chemical mechanical wafer polishing machine.

Figure 5 is a perspective view of the belt support assembly of the polishing machine of Figure 4.

Figure 6 is a perspective view at an expanded scale of a portion of the belt support assembly of Figure 5.

Figure 7 is a top view of the belt support assembly of Figure 5.

Figure 8 is a top view of another belt support assembly suitable for use in the polishing machine of Figure 4.

Figure 9 is a cross-sectional view taken along line 9-9 of Figure 8.

Figure 10 is a cross-sectional view taken along line 10-10 of Figure 9.

Figure 11 is a side view taken along line 11-11 of Figure 10.

Figure 12 is an enlarged view of a portion of the belt support assembly of Figure 9.

Figure 13 is a top view of another belt support assembly.

[0009] Turning now to the drawings, Figures 1-3 relate to a chemical mechanical wafer polishing machine 10 that incorporates a wafer holder 12 which holds a wafer W against a polishing pad assembly 14. The polishing pad assembly 14 includes a belt 16 which carries on its outer surface one or more polishing pads 18. The belt 16 travels over rollers 20 which are driven in rotation to cause the belt to move linearly past the wafer holder 12. The belt 16 is supported with respect to movement away from the wafer W by a belt support assembly 22 which is shown more clearly in Figure 2. The belt support assembly 22 includes a support 24 which is fixedly mounted in position with respect to the rollers 20. This support 24 defines a hemispherical recess 26 which supports a belt platen 28. The belt platen 28 defines a lower hemispherical surface 30 that is received within the recess 26 to form a ball joint. The uppermost portion

of the platen 28 defines a belt support surface 32. The belt 16 may be wetted and the belt support surface 32 may be grooved to prevent the belt 16 from hydro-planing. Alternatively, the belt support surface 32 may be formed of a low-friction bearing material.

[0010] Further details regarding the wafer polishing machine 10 can be found in U.S. patent application Serial No. 08/287,658 filed August 9, 1994, assigned to the assignee of this invention.

[0011] The platen 28 and the support 24 form at least one fluid bearing which allows low-friction movement of the platen 28 with respect to the support 24. Figure 3 is a top view into the recess 26 with the platen 28 removed. As shown in Figure 3, the recess 26 defines a total of five fluid bearings 34 in this embodiment. One of these fluid bearings 34 is larger than the other four and is positioned centrally. The remaining four fluid bearings 34 are positioned symmetrically around the central fluid bearing. Each of the fluid bearings includes a central fluid inlet 36 which is connectable to a source of fluid under pressure and a respective fluid outlet 38 that is annular in shape and extends around the fluid inlet 36. Each fluid outlet 38 is connectable to a drain of fluid at a lower pressure than that of the source. The region of the recess 26 between the fluid inlet 36 and the fluid outlet 38 forms a bearing surface 40. In use, fluid is pumped from the fluid inlet 36 across the bearing surface 40 to the fluid outlet 38. In this way a film of fluid is formed over the bearing surface 40, and it is this film of fluid that supports the hemispherical surface 30 of the platen 28.

[0012] The larger central fluid bearing 34 supports the platen 28 against movement away from the belt 16. The four smaller fluid bearings 34 provide self-centering characteristics in order maintain the platen 28 centered in the recess 26.

[0013] Returning to Figures 1 and 2, the recess 26 and the hemispherical surface 30 are shaped such that the center of rotation 42 of the ball joint formed by the support 24 and the platen 28 is positioned substantially at the front surface of the wafer W that is being polished. In this way, tilting moments on the platen 28 are minimized and any tendency of the ball joint formed by the platen 28 and the support 24 to press the belt 16 with greater force into the leading edge of the wafer W is minimized or eliminated.

[0014] Figures 4-7 relate to a wafer polishing machine in which the belt 16 is supported by a belt support assembly 60. This belt support assembly 60 includes a support 62 which acts as a manifold for pressurized fluid and includes a raised peripheral rim 66 (Figure 5). A plurality of cylindrical tubes 68 are contained within the rim 66, and each of these tubes 68 defines an exposed annular end surface 70. The manifold is connected to the interiors of the tubes 68 via fluid inlets 72, and a plurality of fluid outlets 74 are provided as shown in Figure 7. Individual ones of the tubes 68 are sealed to the support 62 by seals 78 that allow a controlled amount of movement of the tubes 68. For example, the seal 78 can

be formed of an elastomeric O-ring which bears against a lower cap of the tube 68, and the fluid inlet 72 can be a hollow fastener that secures the tube 68 to the support 62 and compresses the seal 78. As best shown in Figures 6 and 7, interstitial spaces 76 between adjacent tubes 68 allow fluid to flow out of the tubes 68 to the fluid outlets 74.

[0015] Simply by way of example, the tubes 68 can define an array having a diameter of about 20cm (eight inches), and 187 tubes can be used, each having an outside diameter of 1.3cm ($\frac{1}{2}$ inch) and an inside diameter of 0.95cm ($\frac{3}{8}$ inch), and the fluid inlets 72 can be about 0.08cm (0.030 inches) in diameter.

[0016] In use, the manifold is connected to a source of fluid such as water at an elevated pressure, and the fluid outlets 74 are connected to a fluid drain at a lower pressure such as atmospheric pressure. Fluid flows into the tubes 68 via the fluid inlet 72, across the end surfaces 70 which act as bearing surfaces, via the interstitial spaces 76 and the fluid outlets 74 to the fluid drain. The fluid flow over the end surfaces 70 provides broad-area support for the belt 16.

[0017] Figures 1-7 are included in co-pending U.S. patent application serial No. 08/321,085, filed October 11, 1994 (Attorney Docket No. 7103/4).

[0018] Turning now to Figures 8-12, these figures show another support 100 that can for example be used to support the polishing pad assembly 14 in the wafer polishing machine 10. This support 100 includes an upper plate 102 and a lower plate 104 which are held together by fasteners 106. As best shown in Figures 9 and 10, the lower plate 104 defines eight fluid supply conduits 108, each having a respective threaded end 110 and a discharge end 112. The threaded ends 110 in use are each connected to a separate respective source of pressurized fluid at a separate respective pressure. The discharge ends 112 are each in fluid communication with a respective one of eight concentric grooves 114. As best shown in Figure 9, adjacent ones of the concentric grooves 114 are separated by lands 118 which define O-ring receiving grooves 118. O-rings 120 are positioned in the grooves 118 to create a seal between the upper and lower plates 102, 104 between adjacent concentric grooves 114.

[0019] As best shown in Figures 8, 9 and 12, the upper plate 102 defines eight circular arrays of fluid pads 122, each array aligned with a respective one of the concentric grooves 114. Each fluid pad 122 is connected by means of an orifice 124 and a bore 126 to the respective groove 114. The central fluid pad 128 is in fluid communication with the innermost concentric groove 114, as shown in Figures 9 and 10.

[0020] In use, fluid is supplied under respective pressures to the conduits 108 and it flows via the conduits 108, the grooves 104, the bores 126 and the orifices 128 to the fluid pads 122. Pressurized fluid then is directed against the polishing pad assembly and it tends to flow radially outwardly to a drain (not shown) at a

lower pressure. Though not intending to be bound by any theory, it is believed that the support 100 may utilize three different modes of lubrication: hydrostatic fluid lubrication at the outer fluid bearing, localized hydrodynamic fluid lubrication inside the hydrostatic region and mixed fluid film lubrication at the points of asperity contact.

[0021] The arrangement shown in Figures 8-12 creates in effect eight separate fluid bearings. Each of these fluid bearings includes a respective circle of fluid pads 122 aligned with the respective concentric groove 114. In addition, the innermost fluid bearing includes the central pad 128. Each of these fluid bearings operates with a fluid such as water conducted via a respective fluid supply conduit 108 at a respective pressure. When the support 100 is used to support a belt type polishing pad assembly 14 (Figure 1), the concentric fluid bearings of the support 100 remain in a fixed position with respect to the wafer being polished. By properly adjusting the fluid pressure in the various fluid bearings, a wide range of pressure profiles can be provided. For example, if a wafer being polished is experiencing non-uniform polishing rates between the periphery and the center of the wafer the pressure of the peripheral fluid bearings can be either increased or decreased with respect to the pressure of the central fluid bearings in order to make the polishing rate more uniform across the surface of the wafer being polished. In effect, the concentric fluid bearings provide concentric regions of support which can be precisely adjusted by adjusting the pressure in the fluid in the respective conduit 108.

[0022] In the embodiment discussed above, the fluid pads 122 direct fluid to support the underside of the polishing pad assembly 14. In an alternate embodiment (not shown), the support 100 can be used with a rotating polishing pad assembly rather than one which moves linearly as described above. Also, though the fluid bearings have been shown on the support, they could be formed on the polishing pad assembly in alternative embodiments.

[0023] It should be understood that the support 60 of Figures 4-7 can be modified to provide multiple regions of support operating at different fluid pressures. For example, the fluid inlets 72 can be connected to separate respective manifolds such that the fluid inlets 72 in concentric rings are supplied with fluid at respective pressures. Alternately, the fluid inlets 72 can be connected to manifolds at respective pressures in other spatial patterns if desired.

[0024] Simply by way of example, the individual fluid pads 122 can be 0.6cm (0.25 inch) in diameter by 0.1cm (0.05 inch) in depth, and the orifices 124 can be 0.05cm (0.020 inches) in diameter. The upper and lower plates 102, 104 can be formed of a stainless steel such as type 304, and the fluid bearings on the support 100 can have a maximum diameter comparable to that of the wafer being polished.

[0025] Figure 13 is a top view of a polishing pad sup-

port 100' that is in many ways identical to the support 100 described above. The upper surface of the upper plate 102' includes drainage features including radial grooves 130' and communicating concentric grooves 132'. All of the grooves 130', 132' are in fluid communication with one another, and the spaces between the grooves 130', 132' and the fluid pads 122' constitute raised lands 134'. Fluid passes from the fluid pads 122' to the grooves 130', 132' over the lands 134'. In this way, drainage of the various fluid bearings is enhanced as the movement of fluid toward the periphery of the upper plate 102' is facilitated by the grooves 130', 132'. In all other respects the support 100' is identical to the support 100 described above.

[0026] In this embodiment, the grooves 130' 132' are approximately 0.1cm (0.05 inch) in depth and are provided with rounded edges to reduce damage to the overlying polishing pad assembly (not shown). The illustrated arrangement provides an asymmetrical arrangement for the grooves 130'. By repositioning the fasteners, it would be possible to achieve a more nearly symmetrical array of grooves 130', which might provide advantages. The grooves 130', 132' could also be adapted for use with the embodiment of Figures 4-7.

[0027] The fluid bearings described above provide a number of important advantages. The constant flow of fluid out of the bearing allows for no slurry contamination. These fluid bearings provide excellent stiffness and wide-area support, thereby reducing or eliminating cantilever bending of the platen. These bearings are nearly frictionless and vibrationless, and therefore they provide the further advantage of reduced noise. These bearings are extremely stable and robust, and they can readily be adjusted merely by controlling fluid pressure.

This lends itself to simple, closed-loop feedback control systems. The preferred bearing fluid is liquid water, which is slurry compatible. These bearings are extremely reliable with hardly any maintenance or wear. [0028] Of course, it should be understood that a wide range of changes and modifications can be made to the preferred embodiments described above. For example, other fluids including gases can be used in place of water. If desired the fluid bearings can be formed on the platen rather than the support, and the fluid inlet and outlet may be formed on different components. The number of concentric fluid bearings can be modified as desired, and it is not essential in all embodiments that the fluid bearings be arranged in a concentric fashion, or that individual fluid bearings have a circular shape. It is therefore intended that the foregoing detailed description be regarded as illustrative rather than limiting, and that it be understood that it is the following claims that are intended to define the scope of this invention.

55 Claims

1. A semiconductor wafer polishing machine (10) of the type comprising at least one polishing pad

assembly (14) and at least one wafer holder (12) positioned to hold a semiconductor wafer (10) against the polishing pad assembly (14), and a support (24, 60, 100, 100') positioned adjacent the polishing pad assembly, characterized in that at least one of said support (24, 60, 100, 100') and said polishing pad assembly (14) comprises a plurality of fluid bearings (34, 70, 122, 128) that support the polishing pad assembly (14) on the support (24, 60, 100, 100'), each of said fluid bearings (34, 70, 122, 128) comprising:

a separate respective fluid supply conduit (36, 72, 108) connectable to a respective source of fluid at a separate respective pressure;

a respective set of fluid pads (40, 122, 122'), each in fluid communication with the respective fluid supply conduit (36, 72, 108), said fluid pads (40, 122, 122') configured to direct fluid from the respective fluid supply conduit (36, 72, 108) to support in part the polishing pad assembly (14) on the support (24, 60, 100, 100').

2. The invention of Claim 1 wherein at least some of the sets of fluid pads (122, 122') are arranged in respective concentric rings.

3. The invention of Claim 1 wherein the polishing pad assembly (14) comprises at least one polishing pad (18) and a belt (16) supporting the at least one polishing pad (18) for linear translation.

4. The invention of Claim 1 wherein the fluid bearings comprise first and second plates (104, 102);

said first plate (104) comprising a plurality of concentric grooves (114), each in communication with a respective one of the fluid supply conduits (108);

said second plate (102) comprising a plurality of sets of orifices (124), each set of orifices (124) overlying and aligned with a respective concentric groove (114);

said first and second plates (104, 102) secured together to hold the orifices (124) in alignment with the respective grooves (114);

each fluid pad (122) formed in the second plate (102) in communication with a respective orifice (124).

5. The invention of Claim 4 further comprising an array of drainage grooves (130', 132') formed in the second plate (102') between the fluid pads (122').

6. The invention of Claim 5 wherein the drainage grooves comprise both radially extending drainage grooves (130') and concentric drainage grooves

(132').

7. The invention of Claim 1 wherein the fluid bearings (34, 70, 122, 128) are separately adjustable with respect to fluid pressure to provide a range of pressure profiles.

8. The invention of Claim 1 wherein the fluid bearings (34, 70, 122, 128) comprise a central bearing (128) and a peripheral bearing (122) and wherein the peripheral bearing (122) surrounds the central bearing (128).

9. A method for adjusting a pressure profile in the polishing machine (10) of Claim 1 comprising the steps of:

connecting each of the fluid supply conduits (36, 72, 108) to one of at least two sources of fluid at separate respective pressures; and adjusting the pressure supplied by at least one source of fluid to at least one of the conduits (36, 72, 108) with respect to a the pressure supplied by the at least one other source of fluid to at least one of the other conduits (36, 72, 108) in order to adjust a pressure profile of the fluid bearings (34, 70, 122, 128).

Patentansprüche

1. Poliermaschine (10) für Halbleiterwafer des Typs, der wenigstens eine Polierkissenbaugruppe (14) und wenigstens einen Waferhalter (12) umfaßt, der so angeordnet ist, daß er einen Halbleiterwafer (W) an der Polierkissenbaugruppe (14) hält, sowie eine Auflage (24, 60, 100, 100'), die an die Polierkissenbaugruppe angrenzend angeordnet ist, **dadurch gekennzeichnet**, daß wenigstens die Auflage (29, 60, 100, 100') oder die Polierkissenbaugruppe (14) eine Vielzahl von Fluidlagern (34, 70, 122, 128) umfaßt, die die Polierkissenbaugruppe (14) auf der Auflage (24, 60, 100, 100') tragen, wobei jedes der Fluidlager (34, 70, 122, 128) umfaßt:

eine entsprechende separate Fluidzuführleitung (36, 72, 108), die mit einer entsprechenden Quelle von Fluid unter einem entsprechenden separaten Druck verbunden werden kann;

eine entsprechende Gruppe von Fluidkissen (40, 122, 122'), die jeweils in Fluidverbindung mit der entsprechenden Fluidzuführleitung (36, 72, 108) stehen, wobei die Fluidkissen (40, 122, 122') so aufgebaut sind, daß sie Fluid aus der entsprechenden Fluidzuführleitung (36, 72, 108) so leiten, daß die Polierkissenbaugruppe (14) teilweise auf der Auflage (24, 60, 100,

100') getragen wird.

2. Erfindung nach Anspruch 1, wobei wenigstens einige der Gruppen von Fluidkissen (122, 122') in entsprechenden konzentrischen Ringen angeordnet sind. 5
3. Erfindung nach Anspruch 1, wobei die Polierkissenbaugruppe (14) wenigstens ein Polierkissen (18) und ein Band (16) umfaßt, das das wenigstens eine Polierkissen (18) linear verschiebbar trägt. 10
4. Erfindung nach Anspruch 1, wobei die Fluidlager eine erste und ein zweite Platte (104, 102) umfassen; 15

die erste Platte (104) eine Vielzahl von konzentrischer Nuten (114) umfaßt, die jeweils in Verbindung mit einer entsprechenden der Fluidzuführleitungen (108) stehen; 20

die zweite Platte (102) eine Vielzahl von Gruppen von Düsen (124) umfaßt, wobei jede Gruppe von Düsen (124) eine entsprechende konzentrische Nut (114) überlappt und auf sie ausgerichtet ist; 25

die erste und die zweite Platte (104, 102) aneinander befestigt sind, um die Düsen (124) auf die entsprechenden Nuten (114) ausgerichtet zu halten; 30

jedes Fluidkissen (122), das in der zweiten Platte (102) ausgebildet ist, mit einer entsprechenden Düse (124) in Verbindung steht. 35

5. Erfindung nach Anspruch 4, des weiteren eine Anordnung von Abflußnuten (130', 132') umfassend, die in der zweiten Platte (102') zwischen den Fluidkissen (122') ausgebildet ist. 40
6. Erfindung nach Anspruch 5, wobei die Abflußnuten sowohl radial verlaufende Abflußnuten (130') als auch konzentrische Abflußnuten (132') umfassen. 45
7. Erfindung nach Anspruch 1, wobei die Fluidlager (34, 70, 122, 128) bezüglich des Fluiddrucks separat reguliert werden können, um ein Spektrum an Druckprofilen zu erzeugen. 50
8. Erfindung nach Anspruch 1, wobei die Fluidlager (34, 70, 122, 128) ein mittiges Lager (128) und ein Umfangslager (122) umfassen, und wobei das Umfangslager (122) das mittige Lager (128) umschließt. 55
9. Verfahren zum Regulieren eines Druckprofils in der Poliermaschine (10) nach Anspruch 1, das die fol-

genden Schritte umfaßt:

Verbinden jeder der Fluidzuführleitungen (36, 72, 108) mit einer von wenigstens zwei Quellen von Fluid auf entsprechenden separaten Drücken; und

Regulieren des Drucks, der von wenigstens einer Quelle von Fluid wenigstens einer der Leitungen (36, 72, 108) zugeführt wird, in bezug auf den Druck, der von der wenigstens einen anderen Quelle von Fluid der wenigstens einen der anderen Leitungen (36, 72, 108) zugeführt wird, um ein Druckprofil der Fluidlager (34, 70, 122, 128) zu regulieren.

Revendications

1. Machine (10) de polissage de tranches semi-conductrices, du type qui comprend au moins un ensemble (14) à tampon de polissage et au moins un support (12) de tranche positionné afin qu'il retienne une tranche semi-conductrice (10) contre l'ensemble (14) à tampon de polissage, et un support (24, 60, 100, 100') disposé près de l'ensemble à tampon de polissage, caractérisée en ce que l'un au moins parmi le support (24, 60, 100, 100') et l'ensemble à tampon de polissage (14) comprend plusieurs paliers fluides (34, 70, 122, 128) qui supportent l'ensemble à tampon de polissage (14) sur le support (24, 60, 100, 100'), chacun des paliers fluides (34, 70, 122, 128) comprenant :

un conduit respectif séparé (36, 72, 108) d'alimentation en fluide qui peut être raccordé à une source respective de fluide à une pression respective séparée, et

un ensemble respectif de tampons fluides (40, 122, 122') communiquant chacun avec le conduit respectif (36, 72, 108) d'alimentation en fluide, les tampons fluides (40, 122, 122') ayant une configuration telle qu'ils dirigent le fluide du conduit respectif (36, 72, 108) d'alimentation en fluide afin qu'ils supportent en partie l'ensemble à tampon de polissage (14) placé sur le support (24, 60, 100').

2. Invention selon la revendication 1, dans laquelle certains au moins des ensembles de tampons fluides (122, 122') sont disposés en anneaux concentriques respectifs.
3. Invention selon la revendication 1, dans laquelle l'ensemble à tampon de polissage (14) comporte au moins un tampon de polissage (18) et une courroie (16) qui supporte le tampon de polissage au moins (18) afin qu'il présente un déplacement linéaire en translation.

4. Invention selon la revendication 1, dans laquelle les paliers fluides comprennent des première et seconde plaques (104, 102),

la première plaque (104) comprenant plusieurs gorges concentriques (114) qui communiquent chacune avec un conduit respectif parmi les conduits (108) d'alimentation en fluide, la seconde plaque (102) comprenant plusieurs ensembles d'orifices (124), chaque ensemble d'orifices (124) recouvrant une gorge concentrique respective (114) et étant aligné sur une telle gorge, la première et la seconde plaque (104, 102) étant fixées mutuellement afin qu'elles maintiennent les orifices (124) dans l'alignement des gorges respectives (114), chaque tampon fluide (122) formé dans la seconde plaque (102) étant en communication avec un orifice respectif (124).

5. Invention selon la revendication 4, comprenant en outre un arrangement de gorges d'évacuation (130', 132') formées dans la seconde plaque (102) entre les tampons fluides (122').

6. Invention selon la revendication 5, dans laquelle les gorges d'évacuation comprennent à la fois des gorges radiales (130') et des gorges concentriques (132') d'évacuation.

7. Invention selon la revendication 1, dans laquelle les paliers fluides (34, 70, 122, 128) sont réglables séparément en pression de fluide pour donner toute une plage de profils de pression.

8. Invention selon la revendication 1, dans laquelle les paliers fluides (34, 70, 122, 128) comprennent un palier central (128) et un palier périphérique (122), et le palier périphérique (122) entoure le palier central (128).

9. Procédé d'ajustement d'un profil de pression dans la machine (10) de polissage selon la revendication 1, comprenant les étapes suivantes :

le raccordement de chacun des conduits (36, 72, 108) d'alimentation en fluide à chacune d'au moins deux sources de fluide à des pressions respectives séparées, et l'ajustement de la pression transmise par au moins une source de fluide à au moins l'un des conduits (36, 72, 108) par rapport à une pression transmise par au moins une autre source de fluide à au moins l'un des autres conduits (36, 72, 108) afin qu'un profil de pression des paliers fluides (34, 70, 122, 128) soit ajusté.

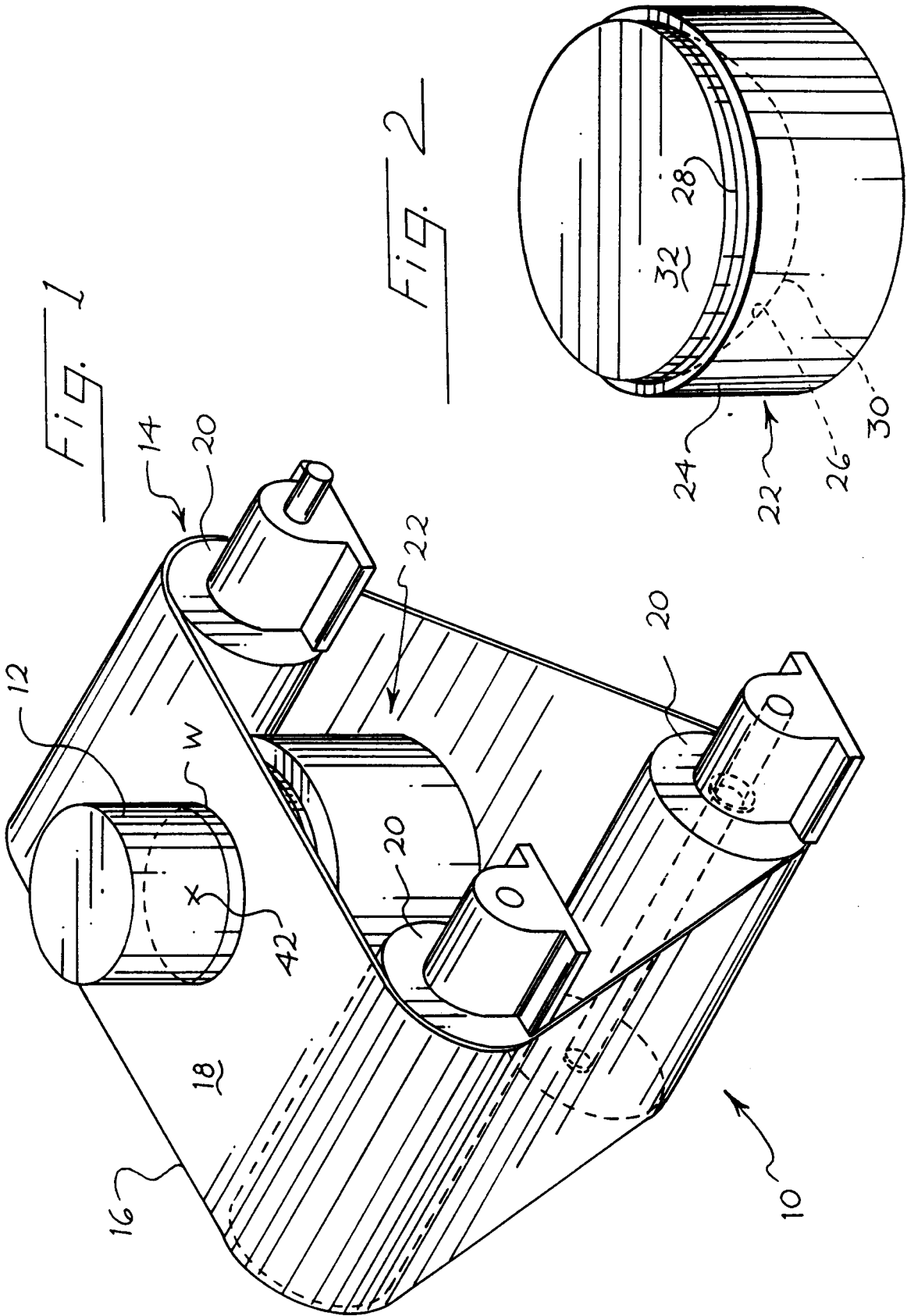

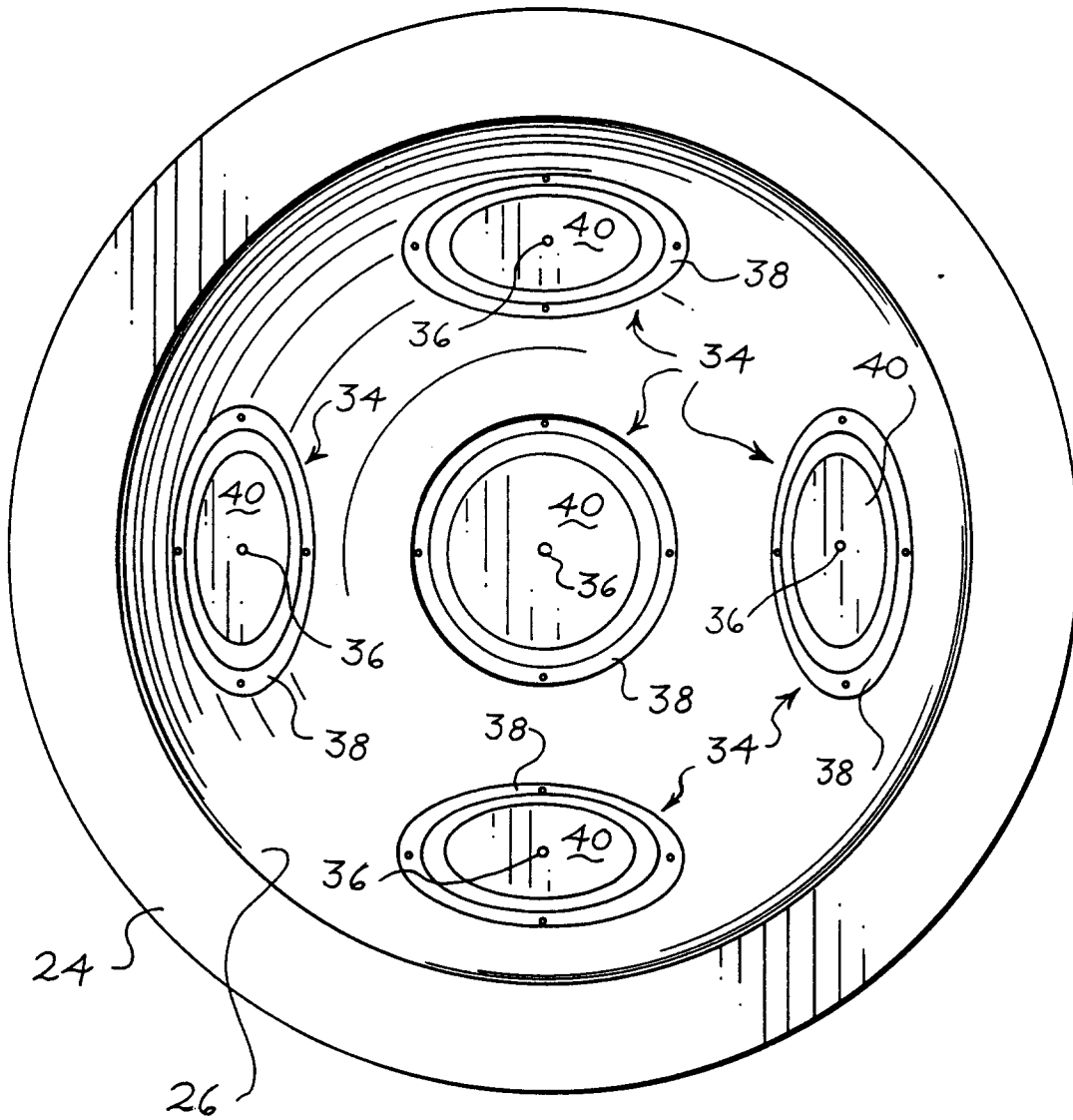
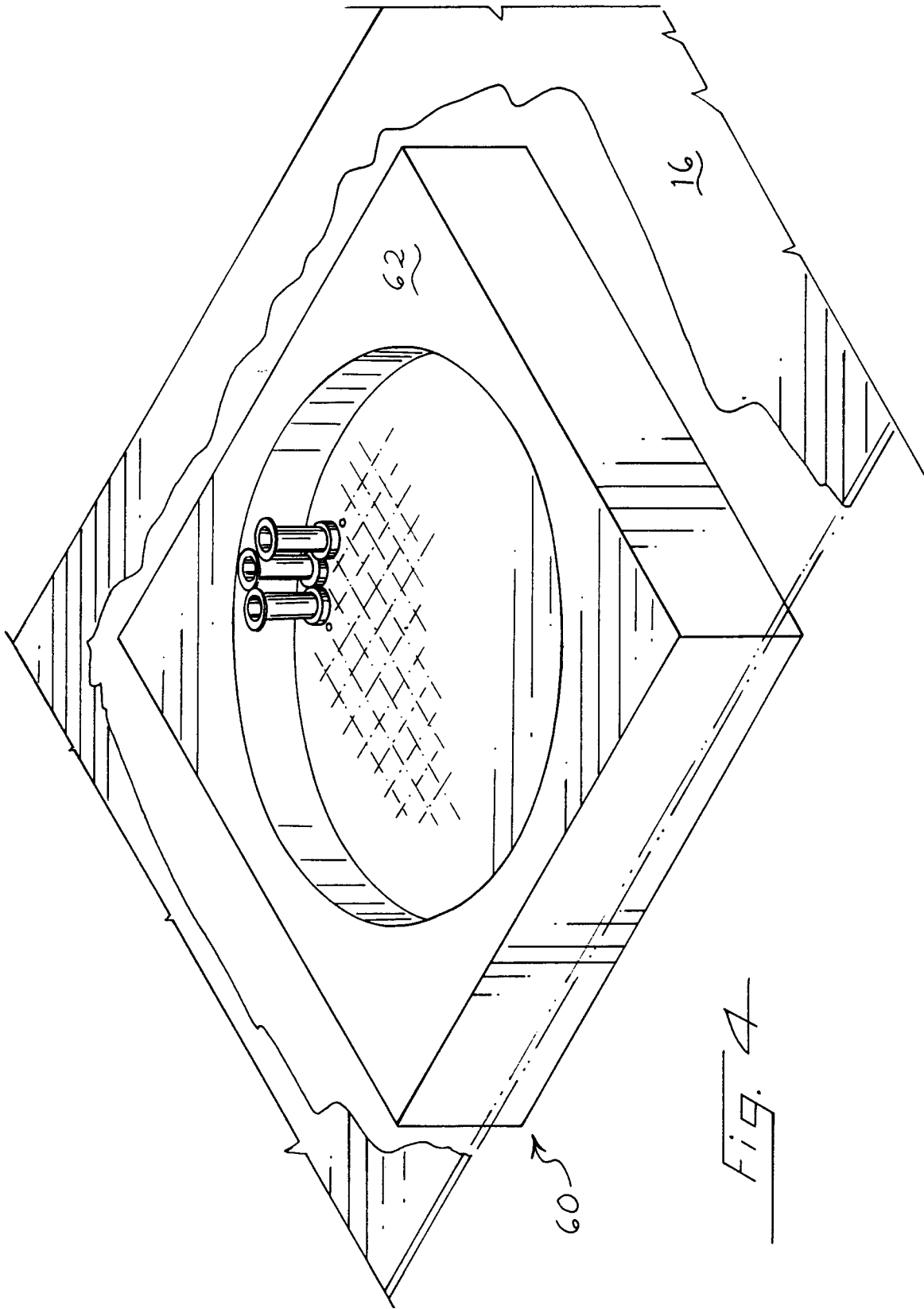

Fig. 3



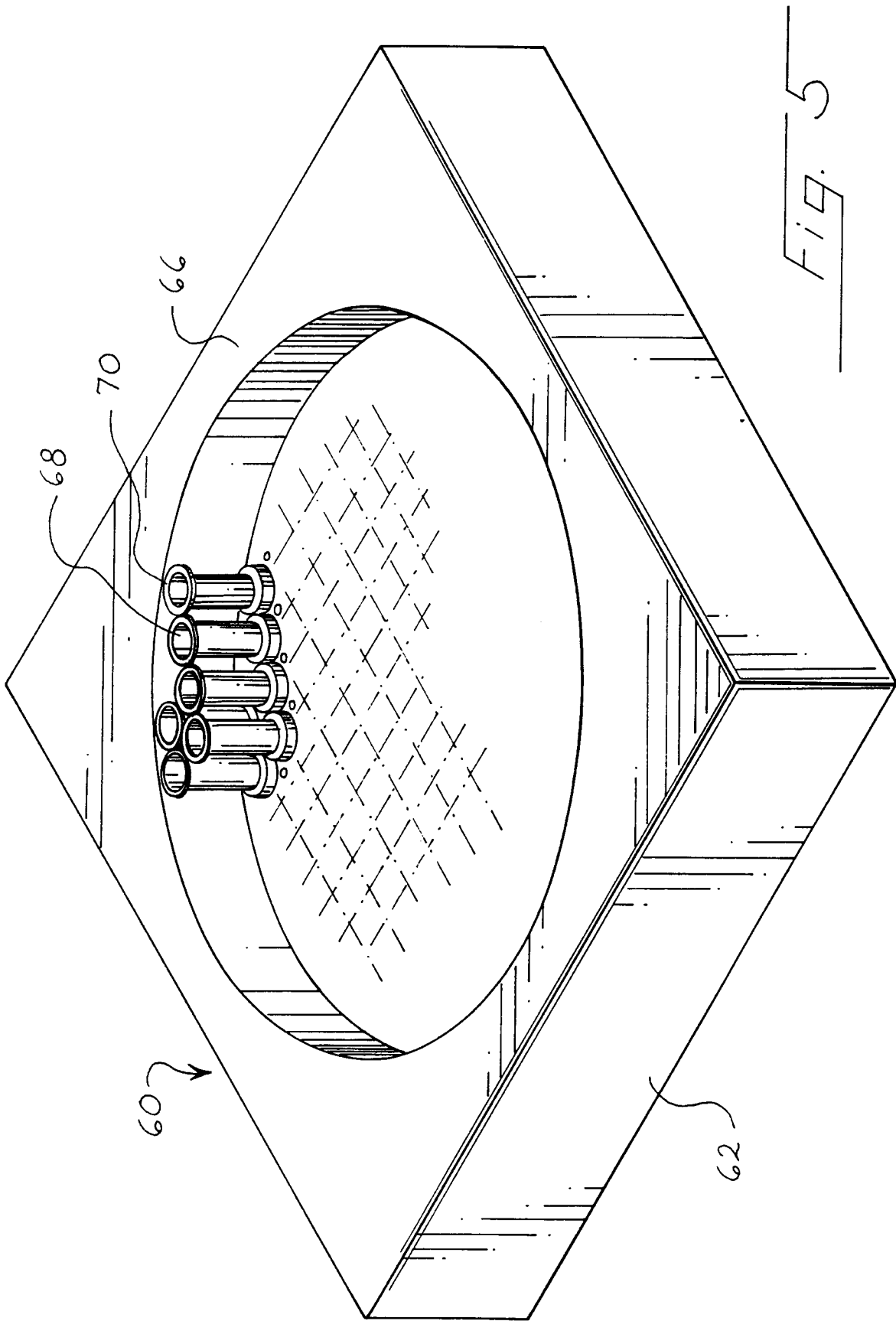

Fig. 5

Fig. 6

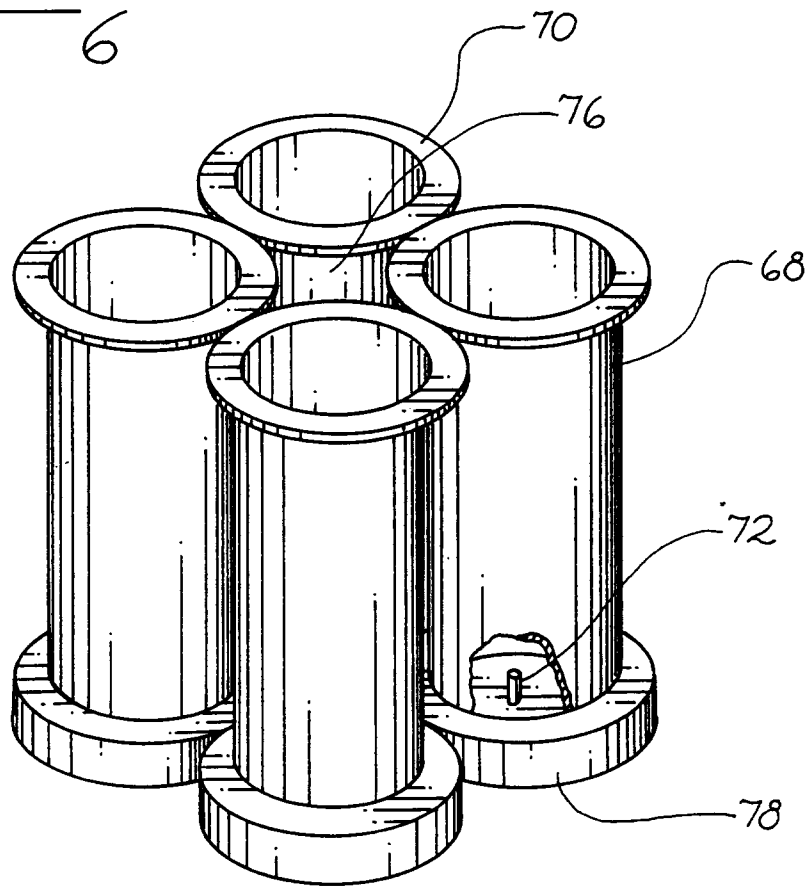
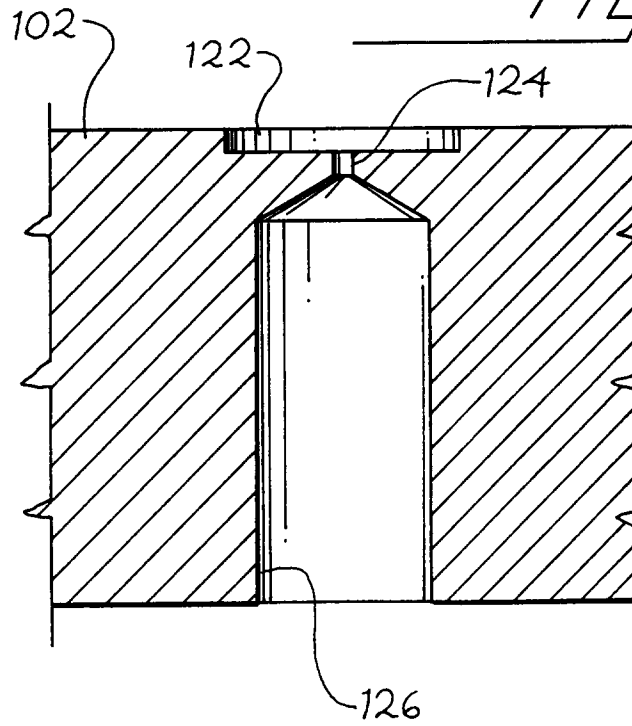

Fig. 12



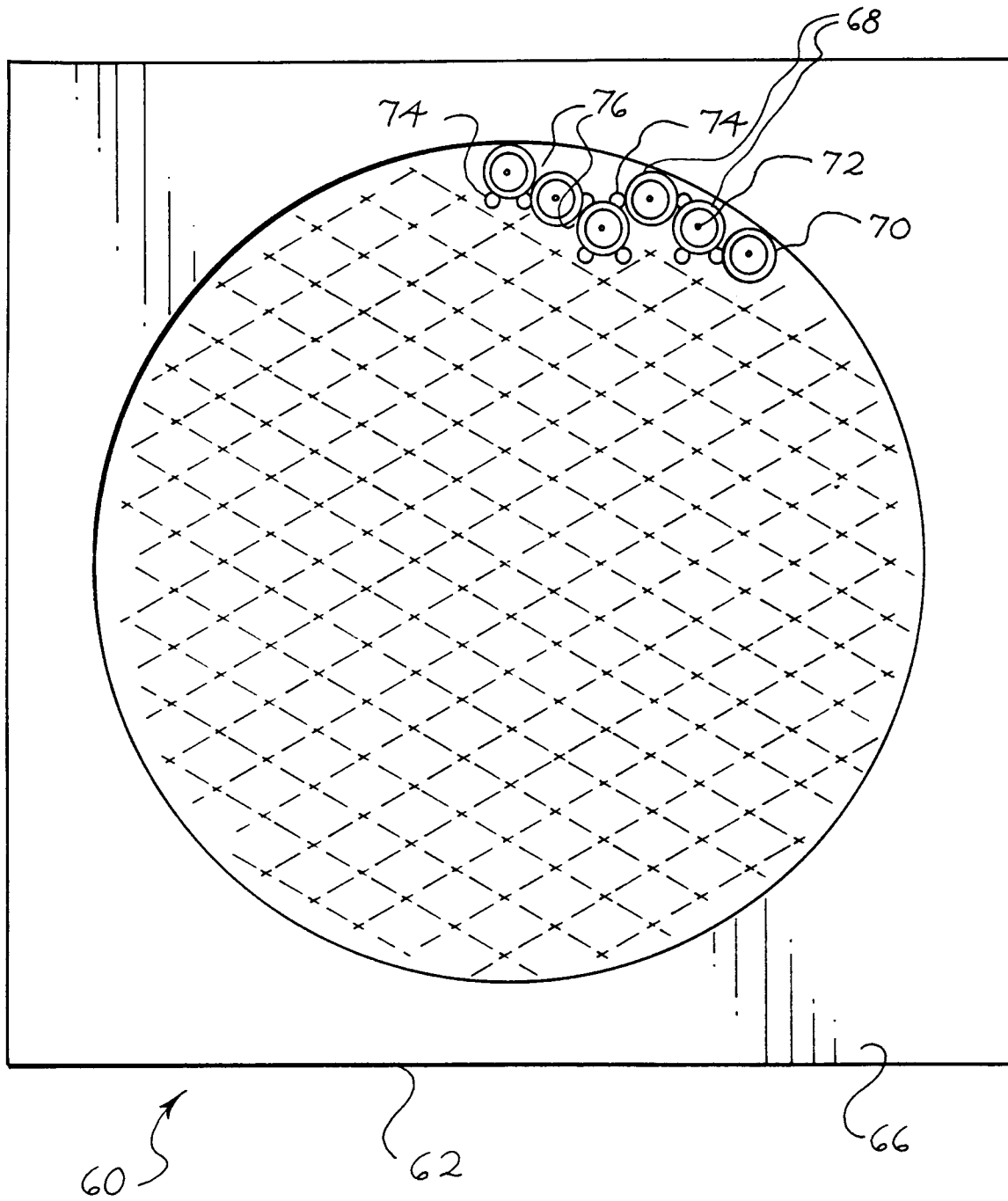

Fig. 7

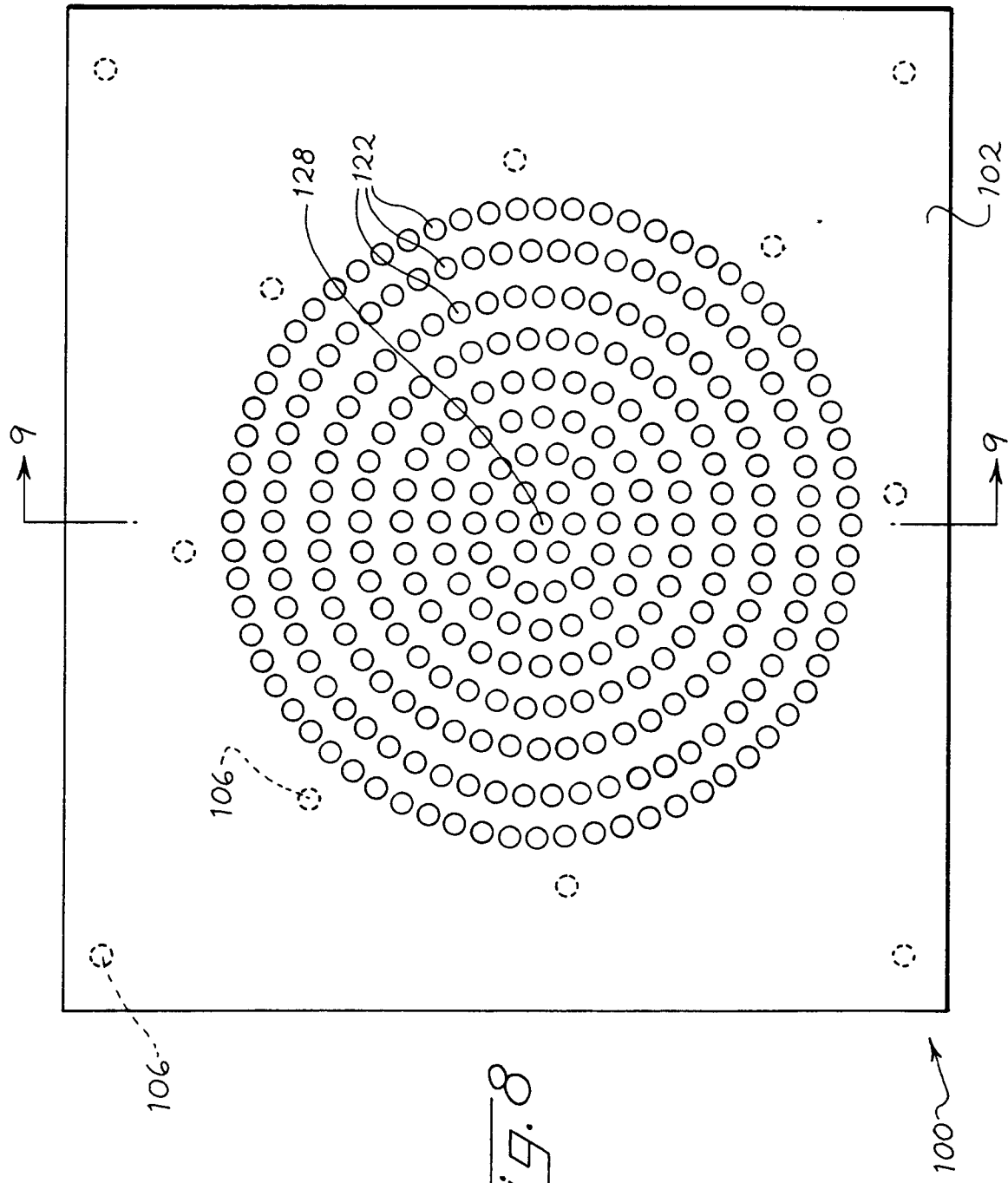

Fig. 8

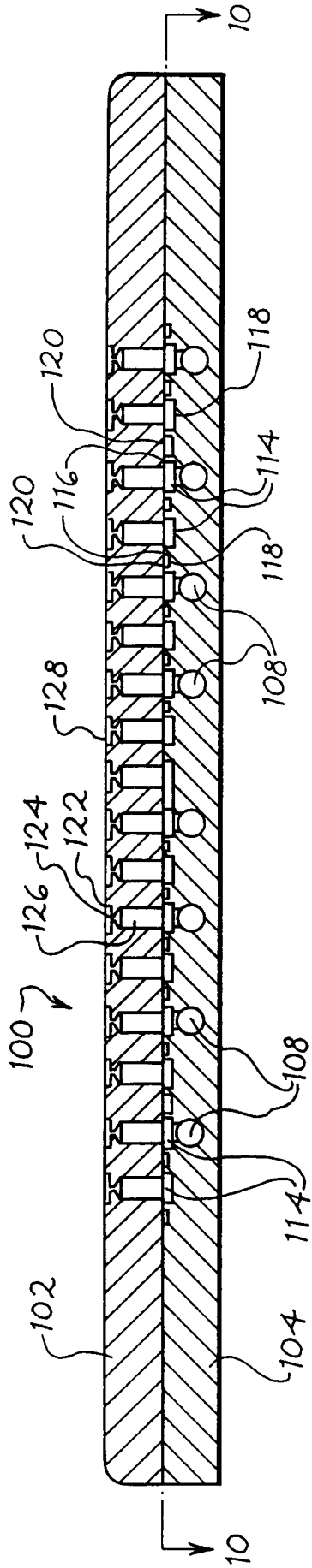

Fig. 9

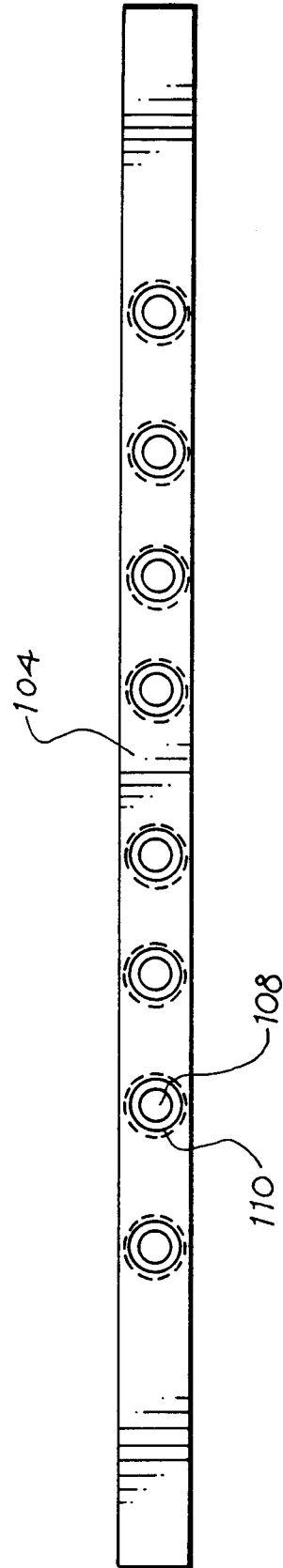

Fig. 11

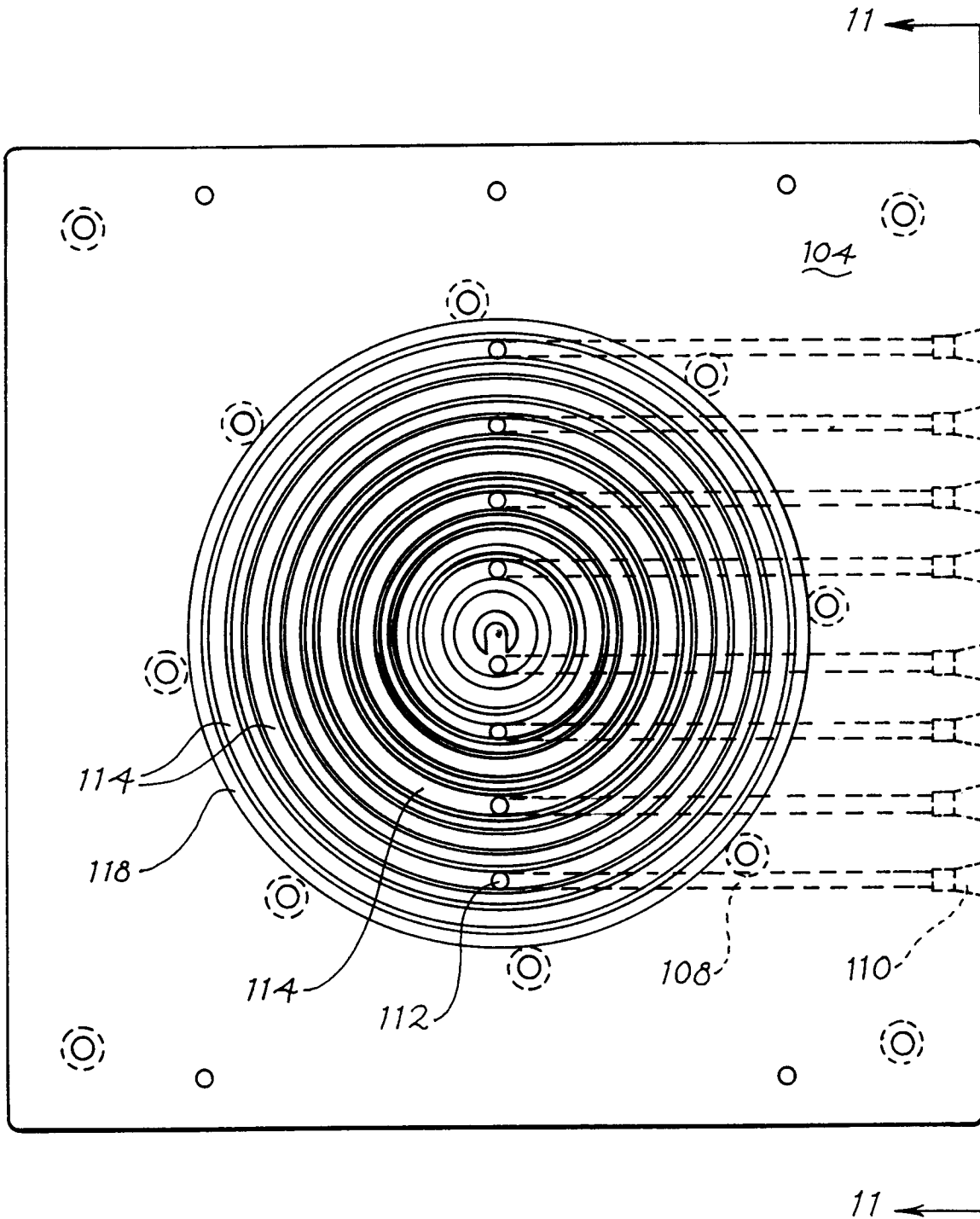

Fig. 10

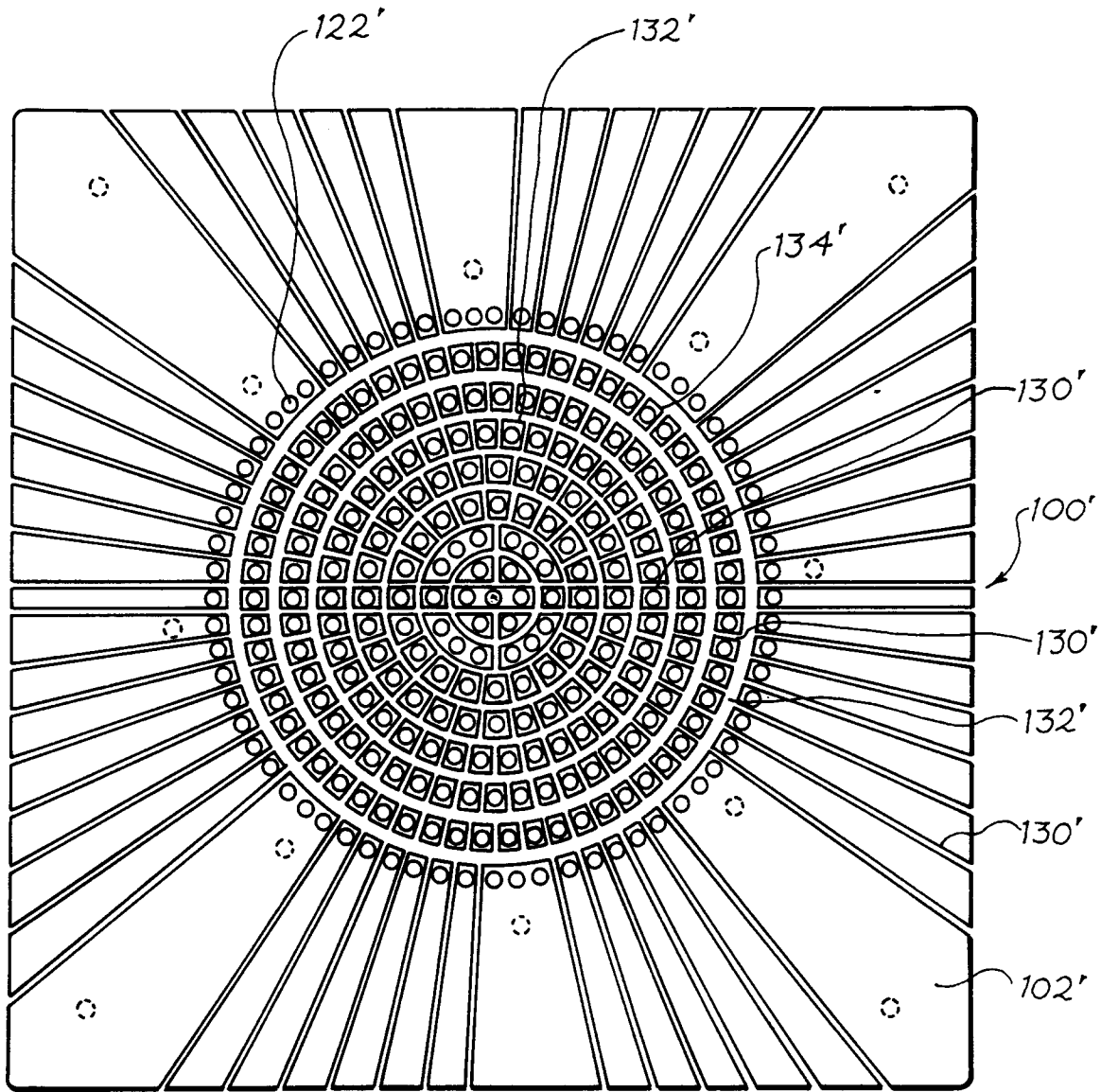

Fig. 13