

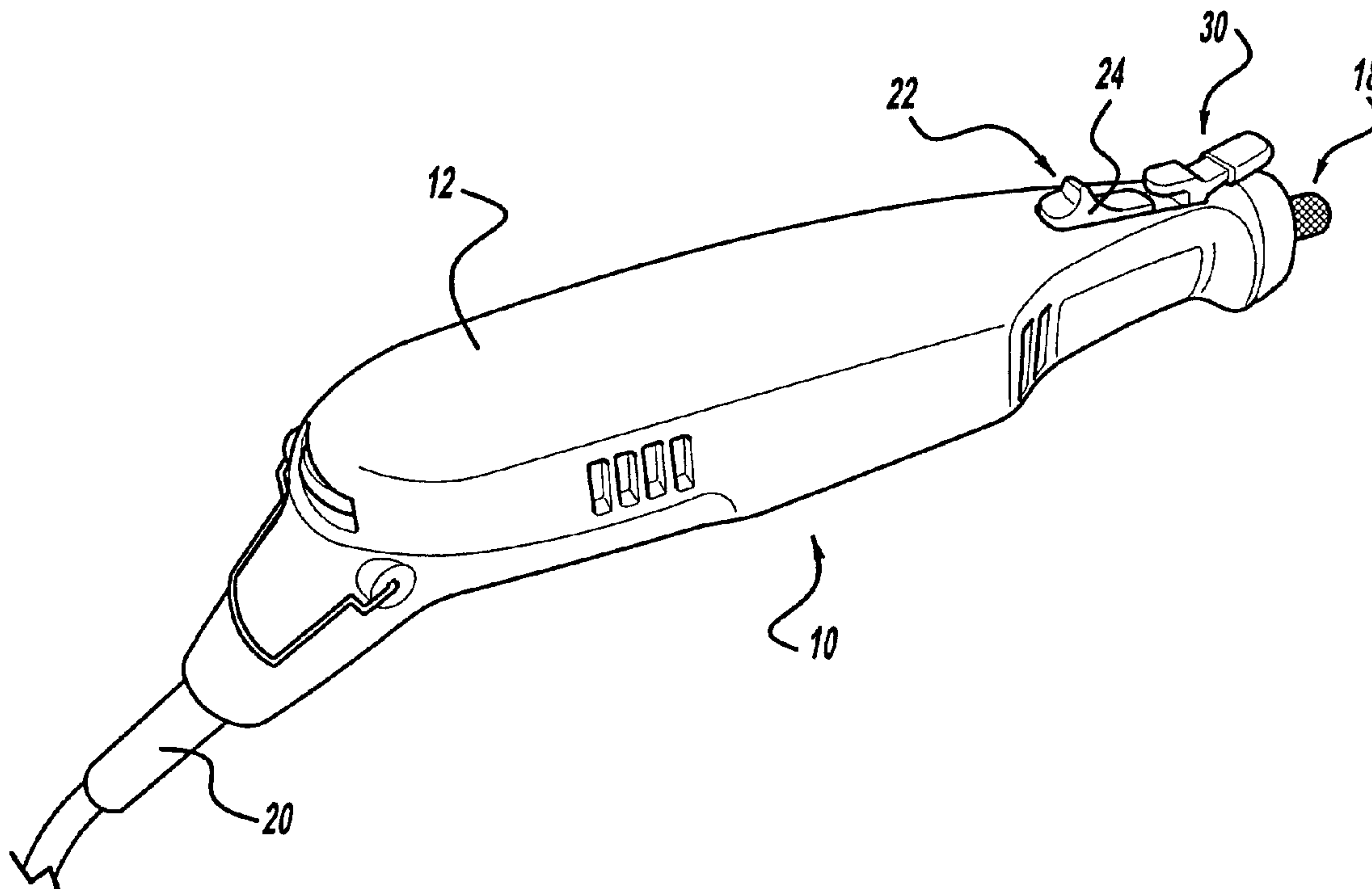

(22) Date de dépôt/Filing Date: 2001/05/28
(41) Mise à la disp. pub./Open to Public Insp.: 2001/12/23
(30) Priorité/Priority: 2000/06/23 (09/603,869) US

(51) Cl.Int.⁷/Int.Cl.⁷ B23B 47/00
(71) Demandeur/Applicant:
BLACK & DECKER INC., US
(72) Inventeurs/Inventors:
SMITH, ROGER Q., US;
KING, WADE C., US
(74) Agent: GOWLING LAFLEUR HENDERSON LLP

(54) Titre : **COMMANDE DE VERROUILLAGE DE BROCHE A SELECTEUR DE VITESSE**
(54) Title: **GEAR AND LEVER SPINDLE LOCK**



(57) **Abrégé/Abstract:**

A power tool with a shaft locking mechanism has a member which is rotatable about a pivot on the housing. The member has a first projection which rotates the member between an engaging and a disengaging position. A gear is secured to the output shaft of the power tool. In a first position, the member does not engage the gear. When the first projection is moved, the member rotates such that a second projection engages the gear. When the second projection engages the gear, this prohibits rotation of the output shaft. To disengage the member, the first projection is moved in the opposite direction which, in turn, disengages the second projection from the gear enabling rotation of the output shaft.

Abstract of the Disclosure

A power tool with a shaft locking mechanism has a member which is rotatable about a pivot on the housing. The member has a first projection which rotates the member between an engaging and a disengaging position. A gear is secured to the output shaft of the power tool. In a first position, the member does not engage the gear. When the first projection is moved, the member rotates such that a second projection engages the gear. When the second projection engages the gear, this prohibits rotation of the output shaft. To disengage the member, the first projection is moved in the opposite direction which, in turn, disengages the second projection from the gear enabling rotation of the output shaft.

GEAR AND LEVER SPINDLE LOCK

Background and Summary of the Invention

The present invention relates to power tools and, more particularly, to power tools having a device for locking the spindle against rotation.

5 In rotary tools that are used by hobbyists, several different types of bits are used in the rotary tool. Ordinarily, a collet is present which receives the tool bit. The collet is tightened to retain the tool bit within the collet on the tool. Ordinarily, these collets are tightened by the rotation of a collet nut to provide the frictional force necessary to retain the tool bit within the collet. In order to loosen or tighten the collet nut to release a tool bit or secure a tool bit, respectively, the collet nut must be rotated. 10 In order to rotate the collet nut with respect to the tool motor, it is desirable to inhibit rotation of the motor shaft of the tool so that the collet nut may be rotated. One type of device utilized to accomplish this task is a push button mechanism which, in turn, prohibits rotation of the motor shaft. While this device works satisfactorily for its intended purpose, designers are always striving to improve the art.

15 The present invention provides the art with a rotatable member which, when it is rotated into a lock position, prohibits rotation of the output spindle. The member may be rotated to its locked position and released, enabling the user to easily access the collet nut. The rotatable member includes a mechanism to receive the on/off switch, as well as to prohibit activation of the on/off switch while it is in its locked 20 position. Further, a device is provided to positively set the rotating member in a locked and unlocked position.

In accordance with a first aspect of the invention, a shaft locking mechanism for a power tool comprises a member adapted to be rotatable about a pivot. The member has a first projection to rotate the member about the pivot. The member has

a second projection to engage a gear. A gear is adapted to be secured on a shaft of the power tool. The first projection rotates the member between an engaged position, where the second projection engages the gear prohibiting rotation of the output spindle, to a disengaged position, where the second projection disengages from the gear, enabling rotation of the output spindle. The member also includes a receiving portion to receive an on/off switch of the power tool. The member includes at least one detent associated with a spring member to hold the member in the engaged or disengaged position. The spring member positively sets the member in the engaged and disengaged position. A pair of detents, one for the engaged position and one for the disengaged position, are formed in the member. In a first position, the first projection is parallel with respect to a central axis of the tool where the member is in a disengaged position. In a second position, the first projection is perpendicular to the central axis and the second projection engages the gear. The member has an annular body with an interior aperture to receive the pivot. The on/off switch is disabled when the first projection is in the perpendicular position. The receiving portion includes a cantilevered member defining a cut-out to receive the on/off switch.

In accordance with a second embodiment of the invention, a power tool comprises a housing with a motor within the housing. The motor is coupled with an output shaft and is also coupled with a power source. An on/off switch on the housing is coupled with the power source and the motor to energize and de-energize the motor. When the motor is energized, the motor rotates the output shaft. A member is coupled with the housing to prohibit rotation of the output shaft. The member has a first projection for rotating the member about a pivot on the housing. The member has a second projection to engage a gear on the output shaft. A gear is adapted to be secured on the output shaft. The first projection rotates the member between an engaged position, where the second projection engages the gear prohibiting rotation

of the output shaft, to a disengaged position, where the second projection disengages from the gear, enabling rotation of the output shaft. The member also includes a receiving portion to receive the on/off switch of the power tool. The member includes at least one detent associated with a spring member to hold the member in the engaged or disengaged position. The spring member positively sets the member in the engaged and disengaged position. A pair of detents, one for the engaged position and one for the disengaged position, are formed in the member. In a first position, the first projection is parallel with respect to a central axis of the tool where the member is in a disengaged position. In a second position, the first projection is perpendicular to the central axis and the second projection engages the gear. The member has an annular body with an interior aperture to receive the pivot. The on/off switch is disabled when the first projection is in the perpendicular position. The receiving portion includes a cantilevered member defining a cut-out to receive the on/off switch.

Additional objects and advantages of the present invention will become apparent from the detailed description of the preferred embodiment, and the appended claims and accompanying drawings, or may be learned by practice of the invention.

Brief Description of the Drawings

Figure 1 illustrates a perspective view of a rotary tool in accordance with the present invention.

Figure 2 illustrates a partial cross-section view of the rotary tool according to Figure 1.

Figure 3 is a view like that of Figure 2 with the rotary member in a second position.

Figure 4 is a perspective view of the shaft locking mechanism of Figure 3.

Figure 5 is a partial cross-section view like Figure 3 of an additional embodiment of the present invention.

Figure 6 is a perspective view like Figure 4 of the embodiment of Figure 5.

Detailed Description of the Preferred Embodiment

5 Turning to Figures 1 and 2, a rotary tool is illustrated and designated with the reference numeral 10. The rotary tool 10 includes a housing 12 which houses a motor 14. The motor 14 is coupled with an output shaft 16. The output shaft 16 has a collet 18 on its end to receive rotary tool bits. A power source, in this view a cord 20, is coupled with the motor 14 to energize the motor. An on/off switch 22 is electrically
10 coupled with the motor 14 and the power cord 20 to energize the motor 14. The on/off switch 22 includes a sliding member 24 which activates a push button switch 26 which is electrically coupled with the motor 14 and power source 20. A shaft locking member 30 is coupled with the housing 12.

Turning to Figures 2-4, a better understanding of the rotary member 30 can be
15 found. The rotary member 30 has an annular body 32 with an aperture 34 which is received on a pivot pin 36 of the housing 12. The rotary member 30 includes a first projecting member 38. The projecting member 38 enables the user to grab it and rotate the rotary member 30 about the pivot 36. The annular body 32 includes a second projecting member 40 which has an overall tooth shape. A third projecting
20 portion 42 includes a cantilevered portion 44 which defines a cut-out 46 which receives a portion of the sliding on/off switch 24. As can be seen in Figure 2, when the first projection 38 is substantially parallel with the axis of the tool, the on/off switch 24 can be slid into the cut-out 46 to energize the power tool. After use, the on/off switch 24 is slid out of the cut-out 46. When the on/off switch 24 is in the cut-out 46,

the rotating member 30 cannot be rotated and is locked in position when the power tool is energized.

The annular body 32 includes a pair of detents 50 and 52. The detents 50 and 52 receive the head 54 of a spring member 56 which positively holds the rotary member 30 in its engaged and disengaged positions. The head 54 is ordinarily a cap which is connected to a spring 56. The spring 56 and cap 54 are seated in a channel 58 in the housing 12. Thus, as the member 30 is rotated, the cap moves inward into the channel 58 against the bias of the spring 56. The cap 54 cams along the body surface 32 until the spring 56 biases the cap 54 into the second detent 52. In the second detent 52, the rotary member 30 is held in its second or engaged position.

A gear 60 is secured onto the output shaft 16. The gear 60 includes a plurality of teeth 62 positioned about its annular body. The gear 60 is fixed onto the output shaft 16 so that when the tooth projection 40 engages the gear 60 as illustrated in Figure 3, the output shaft 16 is prohibited from rotating. Thus, in order to prohibit rotation of the output shaft 16, the projecting member 38 is rotated until it is substantially perpendicular to the axis of the tool. In this position, the tooth projection 40 meshes between a pair of teeth 62 on gear 60. Thus, the output shaft 16 is prohibited from rotating. Likewise, when the tooth 40 engages the gear 60, the cap 54 of the spring mechanism 56 engages detent 52 as illustrated in Figure 3. Thus, the rotating member 30 is held in position by the spring mechanism frictionally biasing in the detent 52.

As illustrated in Figure 3, the sliding switch 24 cannot be moved forward to energize the motor. Thus, the power tool is locked in an off position when the rotary member 30 engages the gear 60. The projecting member 38 may include a rubber boot 64 to enhance the feel for the user to move it between the engaged and disengaged position.

To disengage the tooth projection 40, the first projection 38 is rotated clockwise until it is substantially parallel with the central axis of the power tool. At this time, the on/off switch 24 can be slid forward to be received within the cut-out 46.

5 The tool may be removed from the collet 18 when the output shaft 16 is prohibited from rotating as illustrated in Figure 3. In order to remove the tool, the tooth projection engages the gear teeth 62 which, in turn, enables the collet nut 64 to be rotated. As the collet nut 64 is rotated, it releases the grasping force on the collet fingers 66 of the collet 68. Thus, as the collet fingers 66 expand, the tool may be removed. To retain the tool, the collet nut 64 is tightened which, in turn, exerts a
10 grasping force on the collet fingers 66 to retain the tool in the collet 68.

Turning to Figures 5 and 6, an additional embodiment of the present invention is shown. The embodiment of Figures 5 and 6 are similar to that of Figures 3 and 4 with the same elements having the same identification numerals. The difference between the figures is the gear 60'. Here, the gear 60' includes teeth 62' which
15 include an angled surface 72'. The angled surfaces act as cam surfaces to engage the tooth 40 of the rotary member 30. Also, the gear 60' includes one tooth 74' which has an angled surface 76'. When viewed in elevation, tooth 74' is axially longer on the gear 60' than the other teeth 62' as seen in Figure 5. Thus, the tooth 74', with its angled surface 76', would be the first tooth to contact the tooth 40 of the rotary
20 member 30 as the tooth 40 attempts to mesh with gear 60' during rotation of the shaft 16 as the shaft 16 winds down.

As the power is terminated to the power tool, the spindle 16 continues to rotate. As the spindle continues to rotate, the gear 60' continues to rotate. If the rotary member 30 attempts to be engaged during this rotation, the tooth 40 contacts the
25 teeth 62' and 74'. Since the tooth 74' is longer than the other teeth 62', the tooth 74' contacts the tooth 40 at a regular duration as the gear and spindle continue to rotate

and slow down. The long tooth 74' contacts the tooth 40 of the rotary member 30 with a strong force, giving a positive feedback to the user that the lever cannot be engaged. The single long tooth enables one tooth to contact the tooth 40 of the rotary member 30 during a single rotation instead of each tooth 62' contacting the tooth 40. The
5 contacting of each tooth would produce a rapid contacting of the tooth 40 and not a solid impact which occurs by the single tooth 74'. Thus, the strong kickout force indicates to the user that the spindle lock is not ready to be engaged since the spindle has not stopped its rotation.

While the above detailed description describes the preferred embodiment of
10 the present invention, the invention is susceptible to modification, variation, and alteration without deviating from the scope and fair meaning of the subjoined claims.

What is Claimed is:

1. A shaft locking mechanism for a power tool, comprising:
a member adapted to be rotatable about a pivot, said member having a first projection for rotating said member about the pivot, and a second projection for engaging a gear; and
5 a gear with one or more teeth adapted to secure with a shaft of the power tool, wherein said first projection rotates said member between an engaged position, where said second projection engages said gear prohibiting rotation of the shaft and a disengaged position, where said second projection disengages said gear enabling rotation of the shaft.
2. The shaft locking mechanism according to Claim 1, wherein said member includes a receiving portion for receiving an on/off switch of the power tool.
3. The shaft locking mechanism according to Claim 1, wherein said member includes at least one detent associated with a spring mechanism for holding said member in said engaged or disengaged position.
4. The shaft locking mechanism according to Claim 3, wherein said member includes a pair of detents, one for holding in said engaged position and the other detent for holding in said disengaged position.

5. The shaft locking mechanism according to Claim 1, wherein said first projection being in a position parallel with respect to a central axis of the tool when in a disengaged position and in a position perpendicular to the central axis in an engaged position.

6. The shaft locking mechanism according to Claim 1, wherein said member has an annular shaped body with an interior aperture for receiving the pivot.

7. The shaft locking mechanism according to Claim 5, wherein the on/off switch being disabled when said first projection is in said perpendicular position.

8. The shaft locking mechanism according to Claim 2, wherein said receiving portion including a cantilevered member defining a cut-out for receiving the on/off switch.

9. A power tool, comprising:
- a housing;
 - a motor in said housing;
 - an output shaft coupled with said motor;
 - 5 a power source coupled with said motor;
 - an on/off switch coupled with said power source and said motor for energizing and de-energizing said motor which, in turn, in the energized mode, said motor rotates said output shaft;
 - a member adapted to be rotatable about a pivot in said housing, said
 - 10 member having a first projection for rotating said member about said pivot, and a second projection for engaging a gear; and
 - a gear with one or more teeth secured with said output shaft of said power tool, wherein said first projection rotates said member between an engaged position, where said second projection engages said gear prohibiting rotation of the
 - 15 shaft and a disengaged position, where said second projection disengages said gear, enabling rotation of the shaft.
10. The power tool according to Claim 9, wherein said member includes a receiving portion for receiving said on/off switch.
11. The power tool according to Claim 9, wherein said member includes at least one detent associated with a spring mechanism for holding said member in said engaged or disengaged position.

12. The power tool according to Claim 11, wherein said member includes a pair of detents, one for holding in said engaged position and the other detent for holding in said disengaged position.

13. The power tool according to Claim 9, wherein said first projection being in a position parallel with respect to a central axis of said tool when in a disengaged position and in a position perpendicular to the central axis in an engaged position.

14. The power tool according to Claim 9, wherein said member has an annular shaped body with an interior aperture for receiving said pivot.

15. The power tool according to Claim 13, wherein said on/off switch being disabled when said first projection is in said perpendicular position.

16. The power tool according to Claim 10, wherein said receiving portion including a cantilevered member defining a cut-out for receiving said on/off switch.

17. The shaft lock according to Claim 1, wherein said gear including a plurality of teeth, each tooth having an angle cam surface for enabling engagement of said second projecting member.

18. The shaft lock according to Claim 17, wherein one of said teeth projects beyond said plurality of teeth enabling said tooth to contact said second projection.

19. The shaft lock according to Claim 1, wherein said gear includes a member for contacting said second projecting member.

20. The shaft lock according to Claim 19, wherein said member extending beyond a plurality of teeth on said gear.

21. The power tool according to Claim 9, wherein said gear including a plurality of teeth, each tooth having an angle cam surface for enabling engagement of said second projecting member.

22. The power tool according to Claim 21, wherein one of said teeth projects beyond said plurality of teeth enabling said tooth to contact said second projection.

23. The power tool according to Claim 9, wherein said gear includes a member for contacting said second projecting member.

24. The power tool according to Claim 23, wherein said member extending beyond a plurality of teeth on said gear.

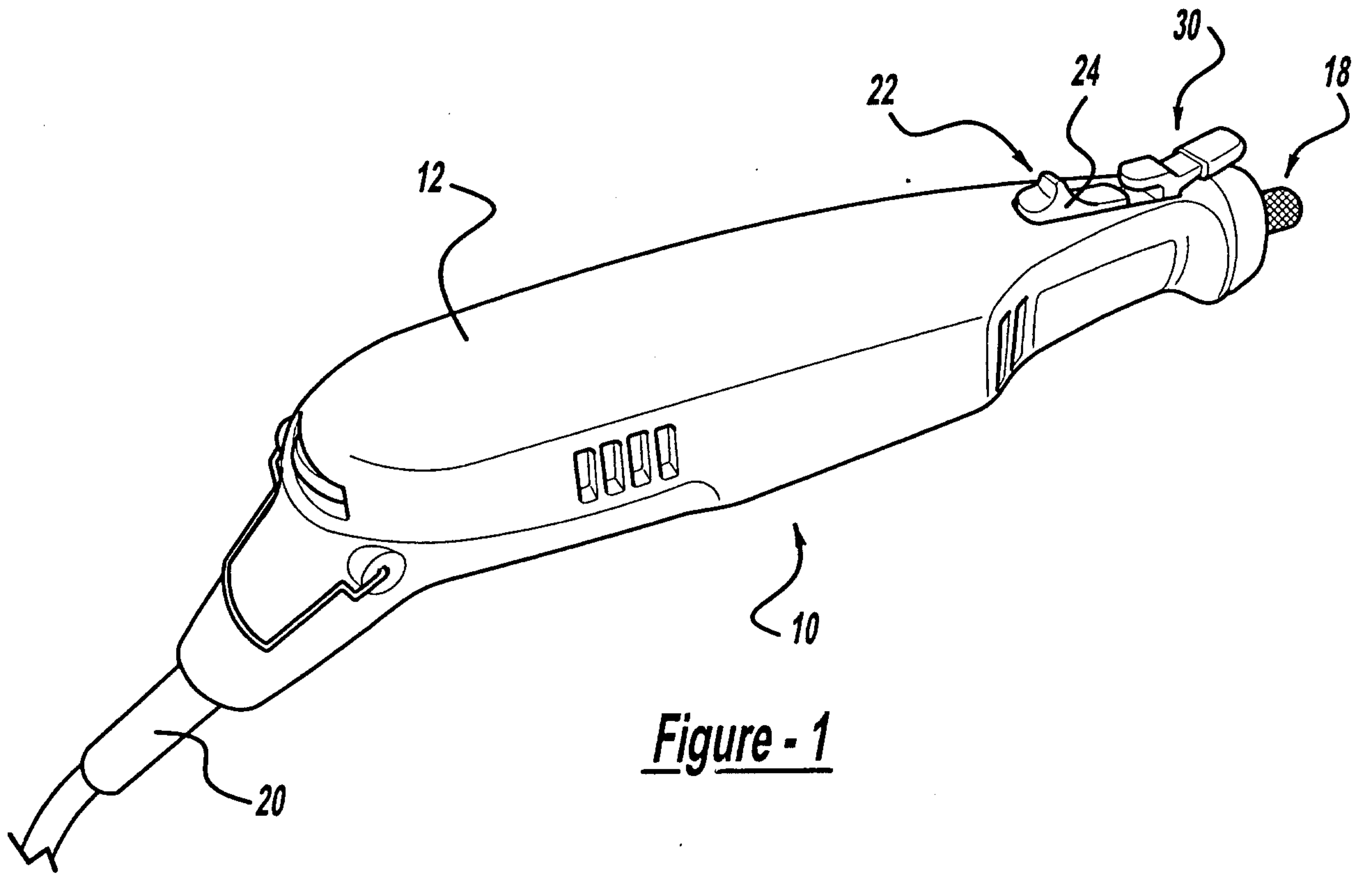

Figure - 1

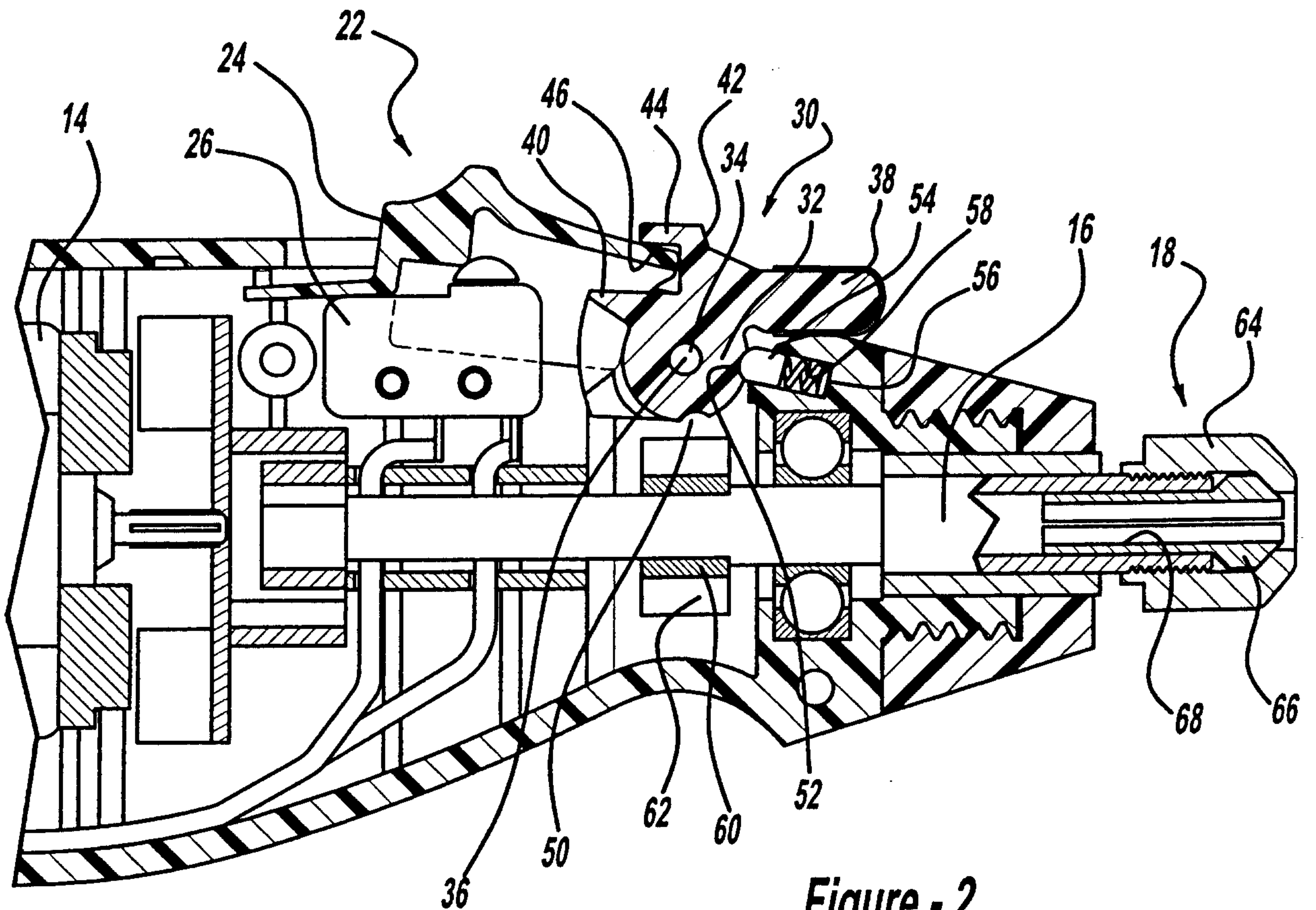

Figure - 2

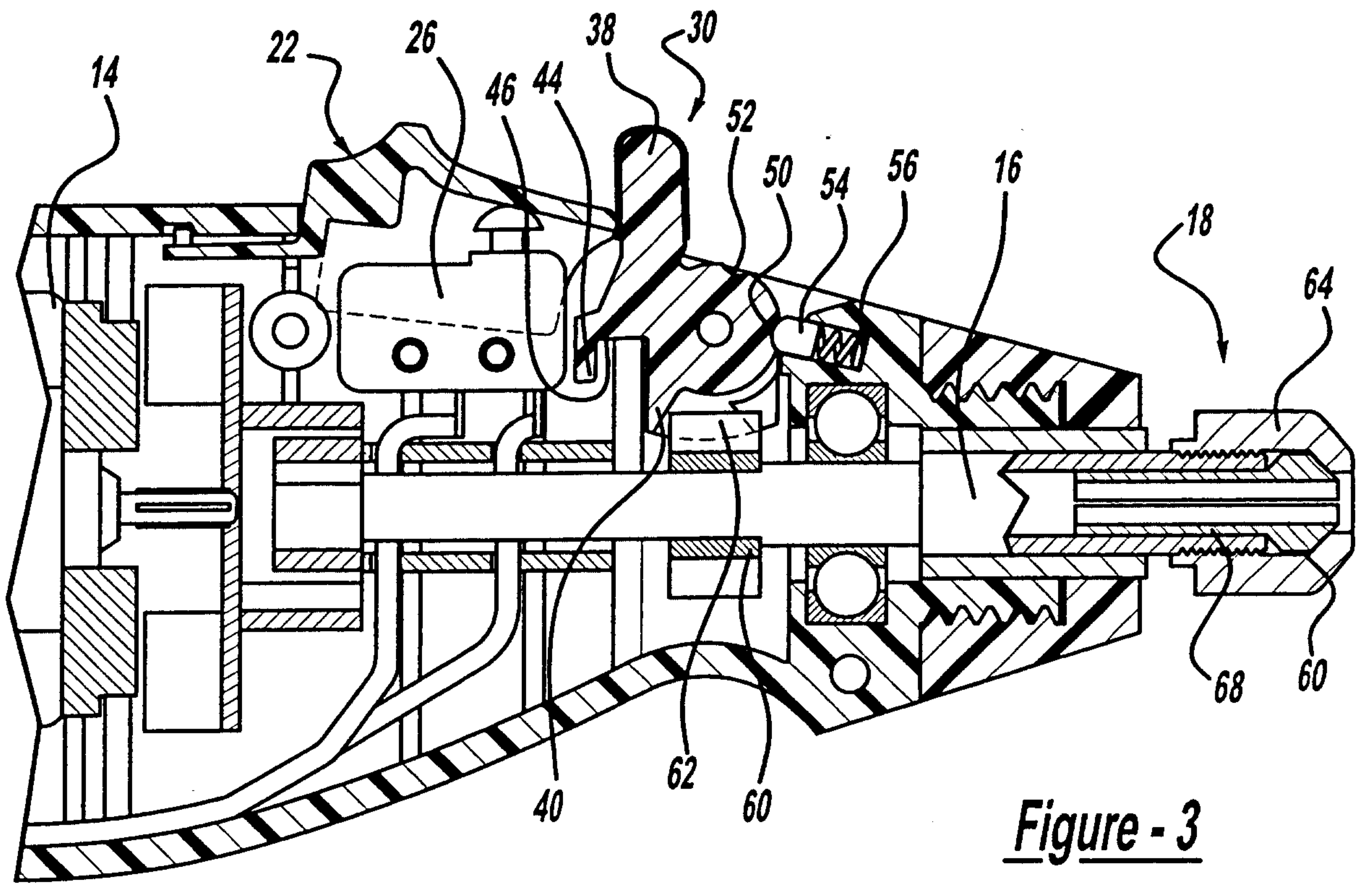

Figure - 3

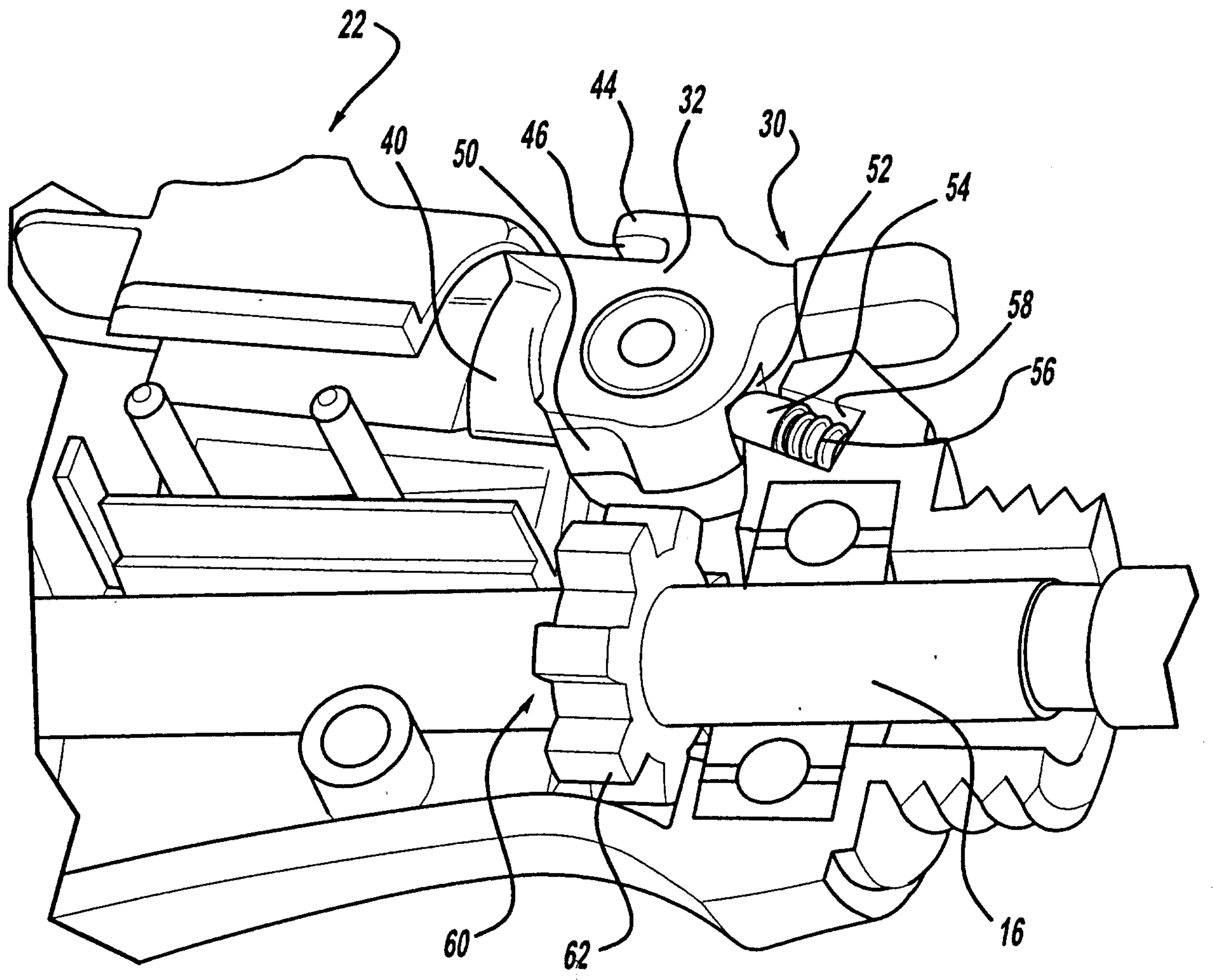

Figure - 4

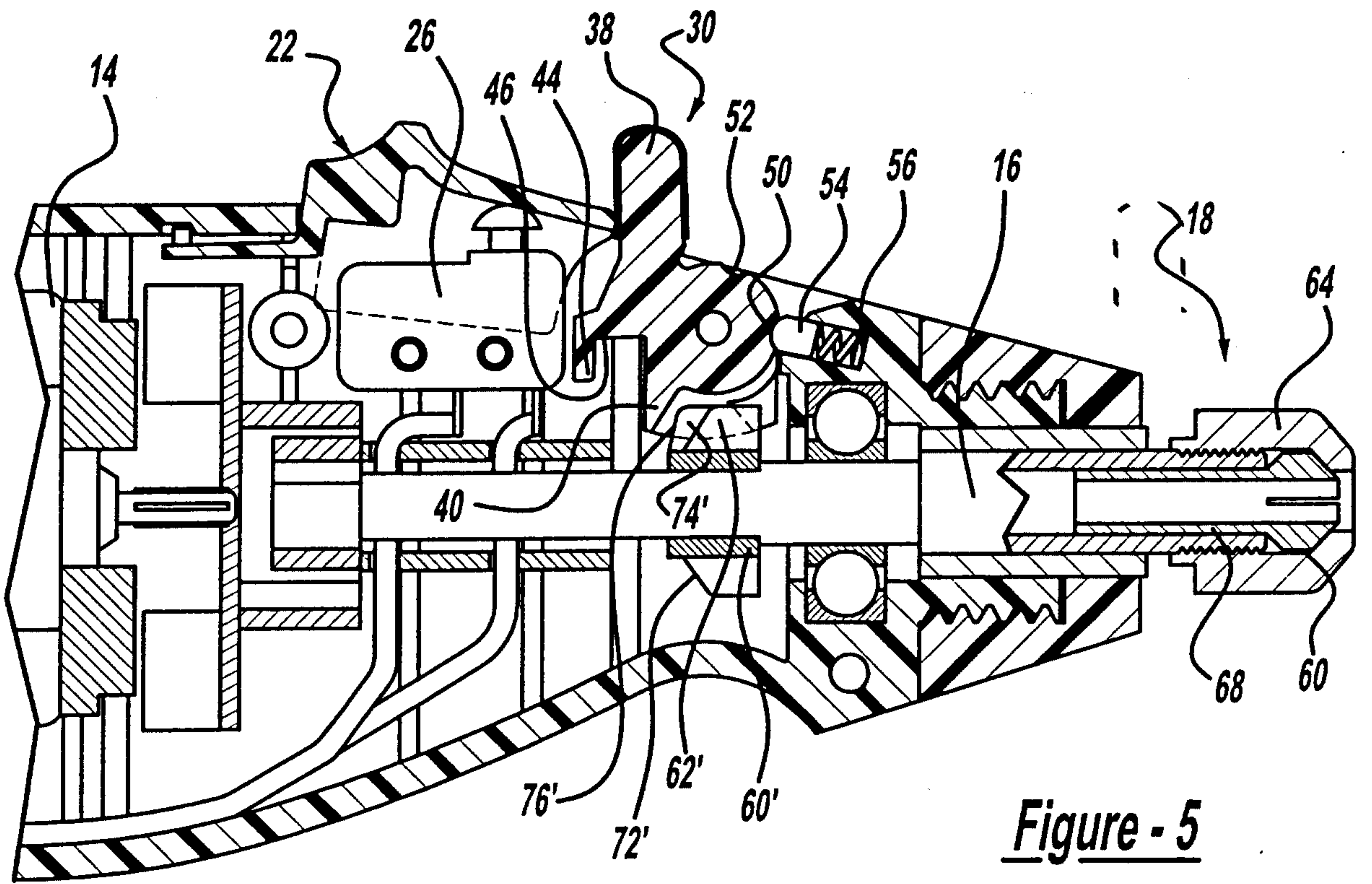

Figure - 5

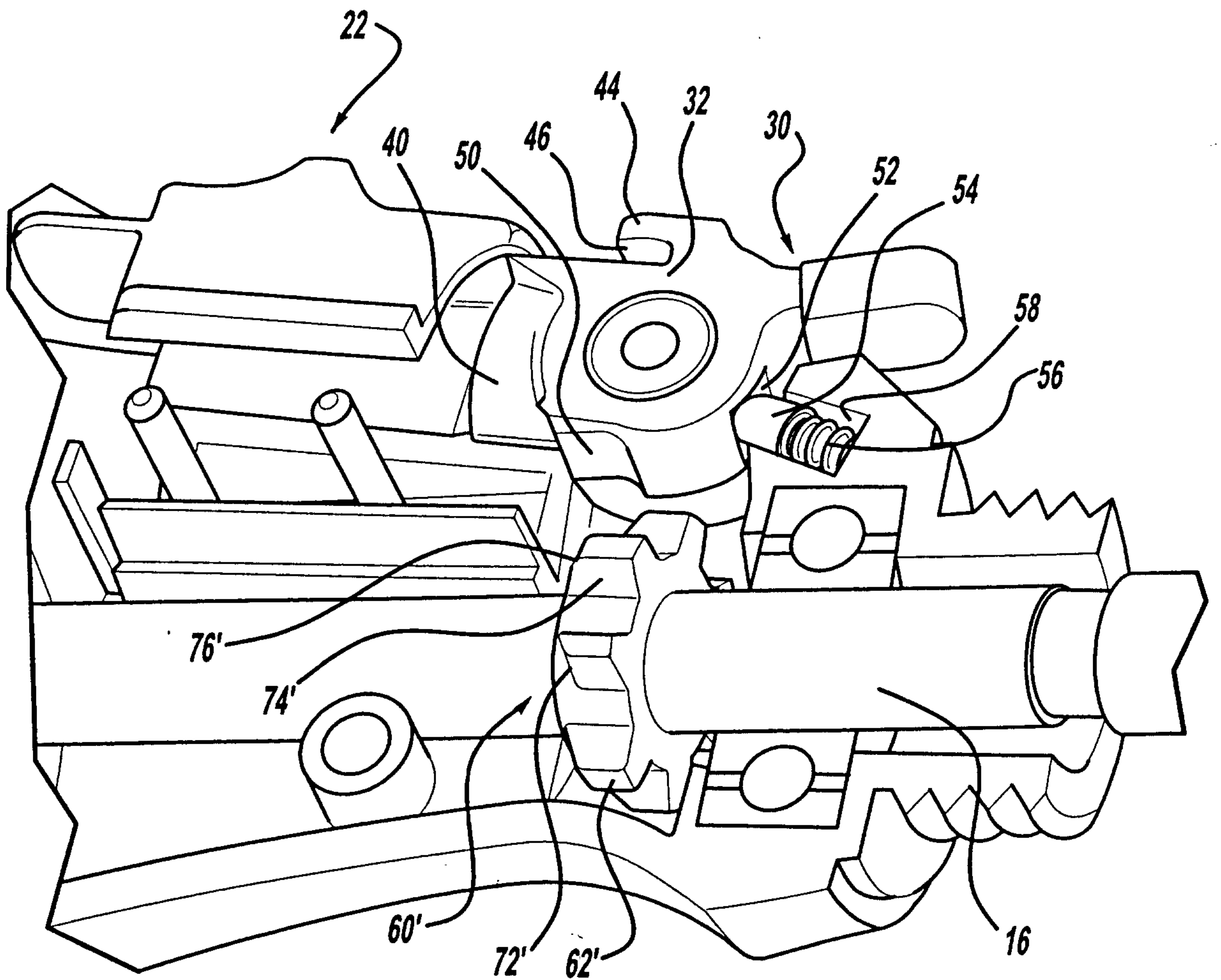

Figure - 6

Gowling Lafleur Henderson LLP

