

(19) AUSTRALIAN PATENT OFFICE

(54) Title
Pressurized liquid fuel vaporizer

(51)⁶ International Patent Classification(s)
F23K 5/22 (2006.01) 43/00
F02B 43/00 (2006.01) 20060101ALI20060101
F02M 21/02 (2006.01) BHAU F02M
F17C 7/04 (2006.01) 21/02
F23K 5/22 20060101ALI20060101
20060101AFI20060101 BHAU F17C 7/04
BHAU F02B 20060101ALI20060101
BHAU

(21) Application No: **2005220249** (22) Application Date: **2005 .10 .07**

(30) Priority Data

(31) Number (32) Date (33) Country
164469 2004 .10 .10 IL

(43) Publication Date : **2006 .04 .27**

(43) Publication Journal Date : **2006 .04 .27**

(71) Applicant(s)
Meir Kozik

(72) Inventor(s)
Kozik, Meir

(74) Agent/Attorney
Spruson & Ferguson, Level 35 St Martins Tower 31 Market Street, Sydney, NSW, 2000

07 Oct 2005

2005220249

PRESSURIZED LIQUID FUEL VAPORIZER
ABSTRACT OF THE DISCLOSURE

5 A device (10) for vaporizing liquid fuel including a plurality of flow column
elements (12), each including a generally vertical tube with an inlet fluid connector (14)
and outlet fluid connector (15) at a top portion thereof, and a generally vertical siphon
tube (16) disposed inside the tube and in fluid communication with the inlet fluid
connector (14) of that tube, a first of the flow column elements (12) being in fluid
communication with a pressurized liquid fuel inlet port (18) connectable to a source of
10 pressurized liquid fuel, and a last of the flow column elements (12) being in fluid
communication with an outlet port (20) connectable to a consumer device, wherein the
flow column elements (12) are connected in series from the first to last flow column
element (12), the siphon tube (16) of one flow column element (12) being fluidly
connected to the outlet fluid connector (15) of the previous, adjacent flow column
15 element (12), and a heater (22) mounted in juxtaposition to the flow column elements
(12).

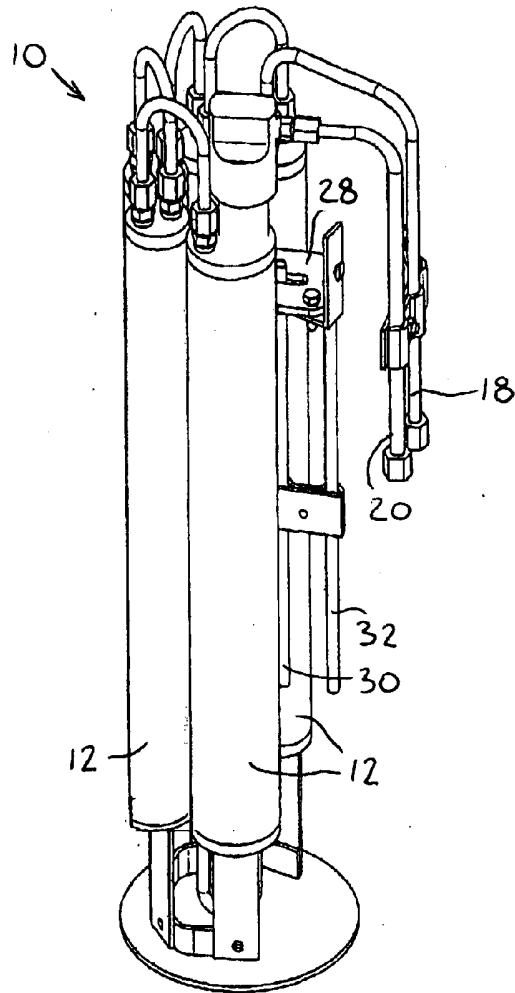
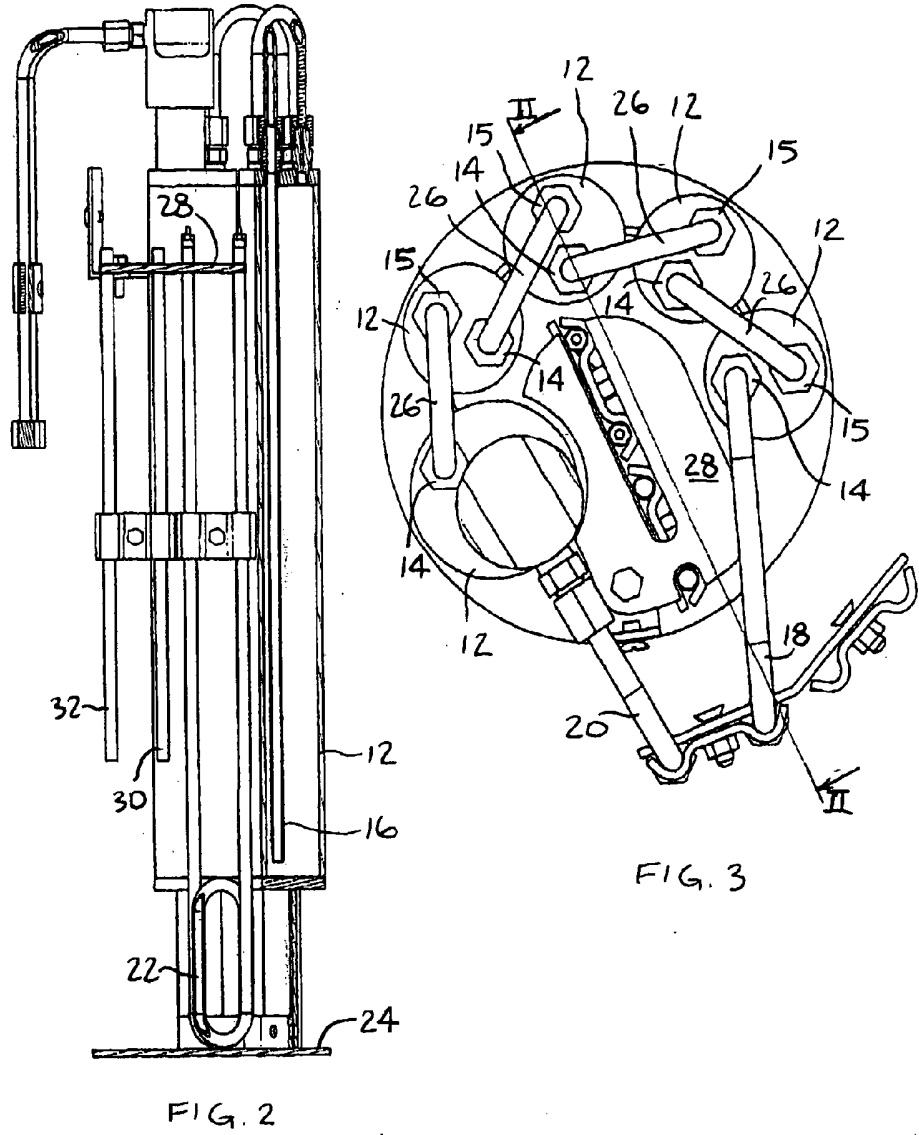

FIG. 1



2005220249 07 Oct 2005

S&F Ref: 738656

AUSTRALIA
PATENTS ACT 1990
COMPLETE SPECIFICATION
FOR A STANDARD PATENT

Name and Address of Applicant : Meir Kozik, of PO Box 221, 60910, Bnei Zion, Israel

Actual Inventor(s): Meir Kozik

Address for Service: Spruson & Ferguson
St Martins Tower Level 35
31 Market Street
Sydney NSW 2000
(CCN 3710000177)

Invention Title: Pressurized liquid fuel vaporizer

The following statement is a full description of this invention, including the best method of performing it known to me/us:-

PRESSURIZED LIQUID FUEL VAPORIZER

FIELD OF THE INVENTION

The present invention relates generally to pressurized liquid fuel tanks and accessories therefor, and particularly to a device for vaporizing liquid fuel and ensuring that vapors are supplied to a consumer of the fuel.

BACKGROUND OF THE INVENTION

Pressurized liquid fuel tanks, such as tanks which contain liquefied petroleum gas (LPG), are used to store such fuel for use by homeowners for cooking and the like, as well as for businesses (e.g., restaurants) and other establishments. The fuel should be completely vaporized by the time it reaches the consumer, but due to various environmental factors, this may not always be the case. Accordingly, it is known in the prior art to heat and vaporize the liquid fuel before supplying it to the consumer.

An example of such a heater and vaporizer is described in French Patent FR2603090. A closed-circuit heater for a pressurized LPG tank includes a heat exchanger to which pressurized liquid fuel is supplied from the tank. The heat exchanger heats the fuel into vapor and the vapors return to the tank in a closed circuit. The heat exchanger uses electrical heating. As is typical of the prior art, the system is horizontal and the heat exchange fluid is forced to circulate substantially from one end to the other of the heat exchanger by a circulation pump.

SUMMARY OF THE INVENTION

The present invention seeks to provide a device for vaporizing liquid fuel and ensuring that vapors are supplied to a consumer of the fuel, as is described in detail further hereinbelow. Unlike the prior art, the system is vertical, which means that any dirt or residual liquid droplets will fall to the bottom of the system and be carried back to the supply tank by differential pressure, and will not pass to the consumer.

There is provided in accordance with an embodiment of the present invention a device for vaporizing liquid fuel including a plurality of flow column elements, each including a generally vertical tube with an inlet fluid connector and outlet fluid connector at a top portion thereof, and a generally vertical siphon tube disposed inside the tube and in fluid communication with the inlet fluid connector of that tube, a first of the flow column elements being in fluid communication with a pressurized liquid fuel inlet port connectable to a source of pressurized liquid fuel, and a last of the flow column elements

being in fluid communication with an outlet port connectable to a consumer device, wherein the flow column elements are connected in series from the first to last flow column element, the siphon tube of one flow column element being fluidly connected to the outlet fluid connector of the previous, adjacent flow column element, and a heater mounted in juxtaposition to the flow column elements.

In accordance with an embodiment of the present invention a first (and second) temperature sensor may be in operative communication with the heater and may cease operation of the heater upon sensing a first (and second) reference temperature.

Further in accordance with an embodiment of the present invention the flow column elements, the heater and the first and second temperature sensors are mounted in a chamber. The heater may include an electric resistance coil positioned at a lower portion of the chamber. The flow column elements, the heater and the first and second temperature sensors may comprise a removable and replaceable unit for assembly into the chamber. The chamber may be at least partially filled with a heat transfer liquid and the fluid column elements may be at least partially submerged in the heat transfer liquid. The chamber may be thermally insulated, as well as a cap adapted to cover the chamber on an upper side thereof.

Still further in accordance with an embodiment of the present invention a cutoff safety valve may be adapted to cut off flow of the liquid in the last of the flow column elements.

BRIEF DESCRIPTION OF THE DRAWINGS

The present invention will be understood and appreciated more fully from the following detailed description taken in conjunction with the drawings in which:

Figs. 1 and 2 are simplified perspective and sectional illustrations, respectively, of a device for vaporizing liquid fuel, constructed and operative in accordance with an embodiment of the present invention;

Fig. 3 is a simplified top-view illustration of the device of Figs. 1 and 2;

Fig. 4 is a simplified sectional illustration of the device of Figs. 1 and 2 assembled in a thermally insulated chamber; and

Fig. 5 is a simplified sectional illustration of flow column element with a cutoff safety valve, useful in the device of Figs. 1 and 2, constructed and operative in accordance with an embodiment of the present invention.

DETAILED DESCRIPTION OF EMBODIMENTS

Reference is now made to Figs. 1-4, which illustrate a device 10 for vaporizing liquid fuel, constructed and operative in accordance with an embodiment of the present invention.

The device 10 may include a plurality of flow column elements 12. Each flow column element 12 comprises a generally vertical tube with an inlet fluid connector 14 and an outlet fluid connector 15 at a top portion thereof. A generally vertical siphon tube 16 (Fig. 2) may be disposed inside the flow column element 12 and in fluid communication with the inlet fluid connector 14. The first of the flow column elements 12 may be in fluid communication with a pressurized liquid fuel inlet port 18 connectable to a source of pressurized liquid fuel (not shown). Accordingly, the siphon tube 16 of the first flow column element 12 is in fluid communication with pressurized liquid fuel inlet port 18. The last of the flow column elements 12 may be in fluid communication with an outlet port 20 connectable to a consumer device (not shown).

The flow column elements 12 are connected in series from the first to last flow column element, the siphon tube 16 of one flow column element 12 being fluidly connected to the outlet fluid connector 15 of the previous, adjacent flow column element 12 via a connecting tube 26, which may be U-shaped. In the non-limiting illustrated embodiment, there are a total of five flow column elements 12, but the invention is not limited to this number. The diameter and length of the flow column elements 12 may be selected to suit the particular application.

In the non-limiting illustrated embodiment, the flow column elements 12 may be mounted on a lower base 24, and may also be attached with any suitable mechanical fastener to a bracket 28.

A heater 22 may be mounted in juxtaposition to the flow column elements 12, and attached to bracket 28. First and second temperature sensors 30 and 32 may be mounted on bracket 28 and may be in operative communication with the heater 22. The first temperature sensor 30 may cease operation of the heater 22 upon sensing a first reference temperature, such as but not limited to, 75°C. The second temperature sensor 32 may cease operation of the heater 22 upon sensing a second reference temperature, such as but not limited to, 85°C. The first and second temperature sensors 30 and 32 may be thermistors or thermocouples, for example.

As seen in Fig. 4, the flow column elements 12, heater 22 and first and second temperature sensors 30 and 32 may be mounted in a chamber 34. The heater 22 may be an

electric resistance coil positioned at a lower portion of the chamber 34. The flow column elements 12, the heater 22 and the first and second temperature sensors 30 and 32 may form a removable and replaceable unit for assembly into chamber 34.

Chamber 34 may be at least partially filled with a heat transfer liquid 36, such as but not limited to, oil. The fluid column elements 12 may be at least partially submerged in the heat transfer liquid 36. Additionally, chamber 34 may be thermally insulated with a layer of thermal insulation 38 on its inner perimeter.

A cap 40 may be provided for covering chamber 34 on an upper side thereof. Cap 40 may be provided with handles and may be clamped or screwed on chamber 34. Cap 40 may also be thermally insulated.

Reference is now made to Fig. 5. A cutoff safety valve 42 may be provided to cut off flow of the liquid in the last of the flow column elements 12, in the event of temperature drops or higher than expected flow rates or other reasons, for example. In the non-limiting illustrated embodiment, valve 42 includes a float 44, which is adapted to rise under fluid pressure applied to an underside thereof and make contact with an aperture 46 in the flow column element 12. The contact is not hermetic and permits a trickle of flow therepast, which means that the float 44 will not get stuck in the closed position. After a power stoppage, for example, there may be liquid in the system up to float 44. After power is restored, and the temperature of the liquid once again rises (e.g., due to heating by heater 22), the residual liquid will flow back through the siphons to the supply tank, due to the differential pressure.

Accordingly, with the present invention, liquid fuel enters pressurized liquid fuel inlet port 18 and flows into the first flow column element 12 through siphon tube 16. The heater 22 raises the temperature of the liquid fuel and vaporizes at least a portion thereof. Vapor and any residual liquid rise and flow through outlet fluid connector 15, pass through connecting tube 26 and enter the siphon tube 16 of the next flow column element 12. Once again, the heater 22 raises the temperature of the fuel and further vaporizes any remaining liquid, or at least a portion thereof. Again, vapor and any residual liquid rise and flow through the outlet fluid connector 15, pass through the connecting tube 26 and enter the siphon tube 16 of the next flow column element 12. The process continues until the fuel is completely vaporized by the time it exits the last flow column element 12. Any dirt or residual liquid droplets will fall to the bottom of the flow column elements 12 and be carried back to the supply tank via the siphon tubes 16 by differential pressure, and may not pass to the consumer

2005220249 07 Oct 2005

5

It is also appreciated that various features of the invention which are, for clarity, described in the contexts of separate embodiments, may also be provided in combination in a single embodiment. Conversely, various features of the invention which are, for brevity, described in the context of a single embodiment, may also be provided separately
5 or in any suitable subcombination.

The claims defining the invention are as follows:

1. A device for vaporizing liquid fuel comprising:
a plurality of flow column elements, each comprising a generally vertical tube with an inlet fluid connector and outlet fluid connector at a top portion thereof, and a
5 generally vertical siphon tube disposed inside the tube and in fluid communication with the inlet fluid connector of that tube, a first of said flow column elements being in fluid communication with a pressurized liquid fuel inlet port connectable to a source of pressurized liquid fuel, and a last of said flow column elements being in fluid communication with an outlet port connectable to a consumer device, wherein said flow
10 column elements are connected in series from the first to last flow column element, the siphon tube of one flow column element being fluidly connected to the outlet fluid connector of the previous, adjacent flow column element; and
a heater mounted in juxtaposition to said flow column elements.
2. The device according to claim 1, further comprising a first temperature
15 sensor in operative communication with said heater and adapted to cease operation of said heater upon sensing a first reference temperature.
3. The device according to claim 2, further comprising a second temperature sensor in operative communication with said heater and adapted to cease operation of said heater upon sensing a second reference temperature.
- 20 4. The device according to claim 3, wherein said flow column elements, said heater and said first and second temperature sensors are mounted in a chamber.
5. The device according to claim 4, wherein the heater comprises an electric resistance coil positioned at a lower portion of said chamber.
6. The device according to claim 4, wherein said flow column elements,
25 said heater and said first and second temperature sensors comprise a removable and replaceable unit for assembly into said chamber.
7. The device according to claim 4, wherein said chamber is at least partially filled with a heat transfer liquid and said fluid column elements are at least partially submerged in said heat transfer liquid.
- 30 8. The device according to claim 4, wherein said chamber is thermally insulated.
9. The device according to claim 4, further comprising a cap adapted to cover said chamber on an upper side thereof.
10. The device according to claim 9, wherein said cap is thermally
35 insulated.

2005220249 07 Oct 2005

7

11. The device according to claim 1, further comprising a cutoff safety valve adapted to cut off flow of the liquid in the last of said flow column elements.

12. A device for vaporizing liquid fuel, said device being substantially as hereinbefore described with reference to the accompanying drawings.

5

Dated 6 October, 2005

Meir Kozik

Patent Attorneys for the Applicant/Nominated Person

SPRUSON & FERGUSON

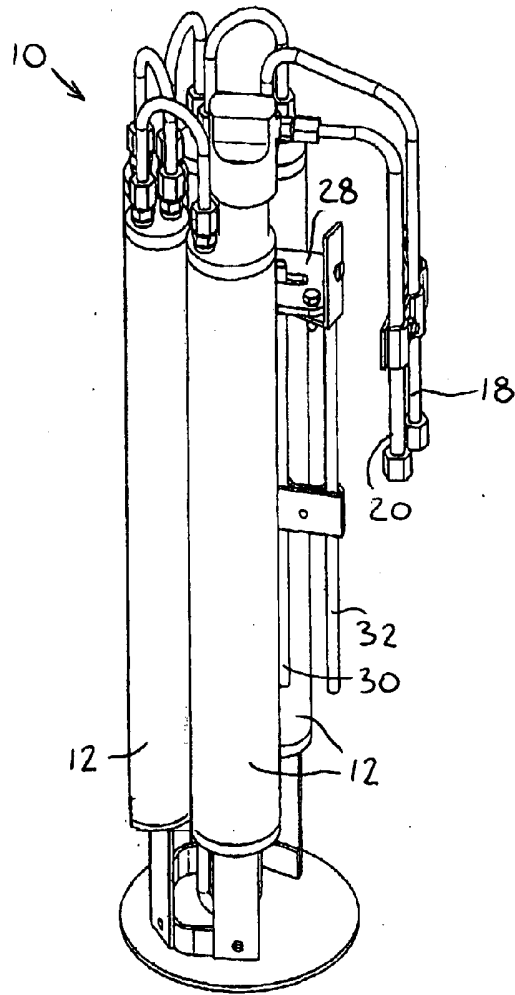
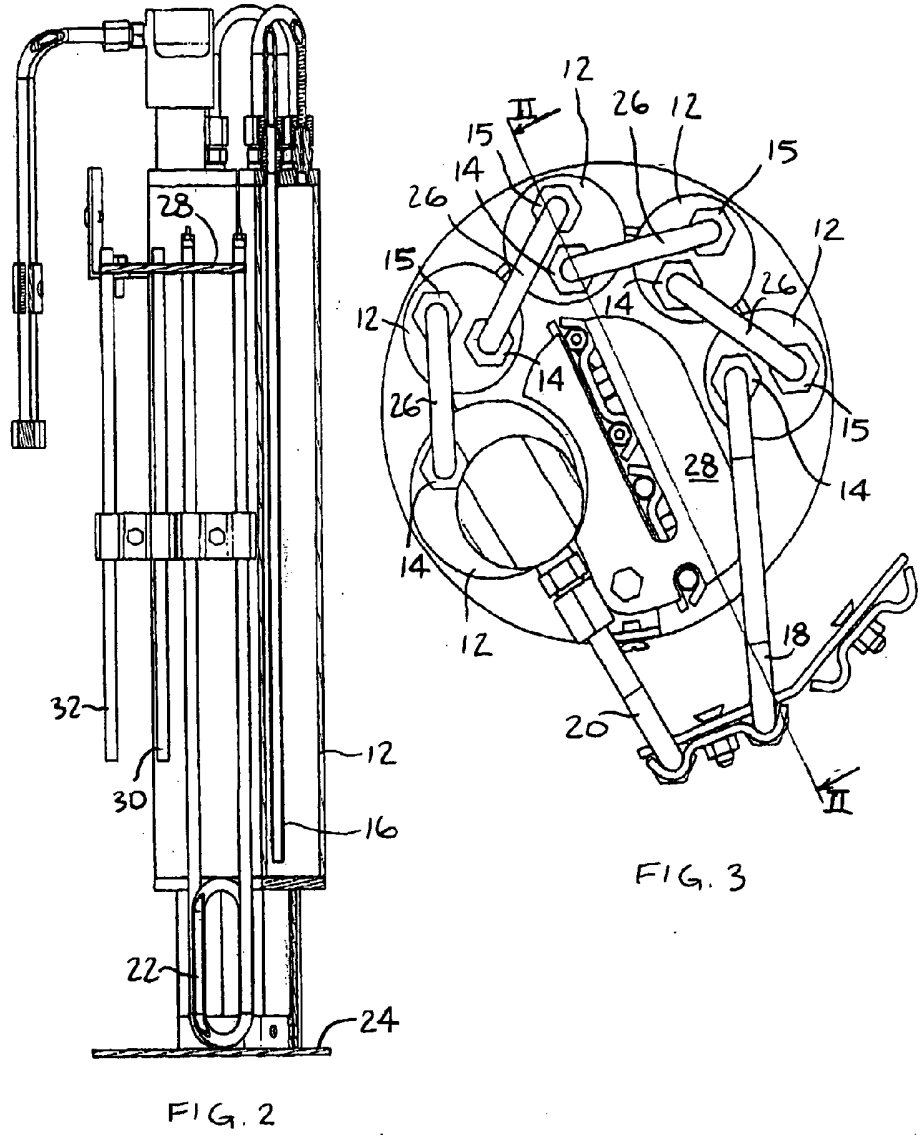

FIG. 1



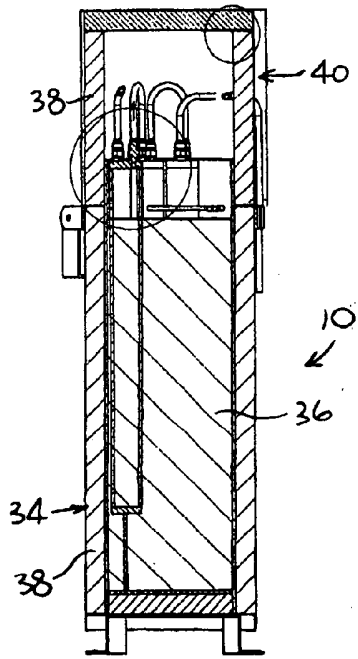

FIG. 4

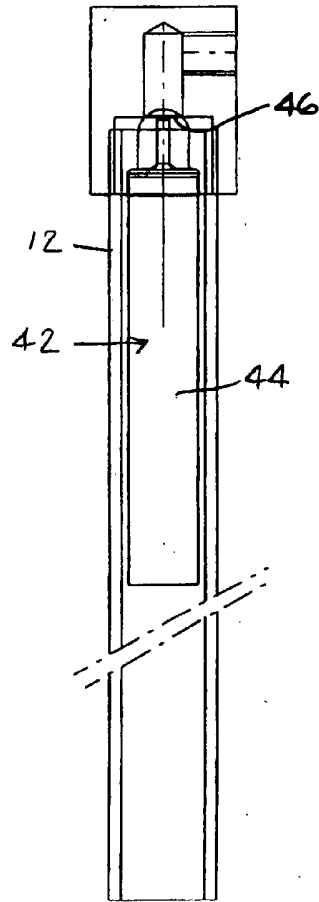

FIG. 5