



(51) International Patent Classification:
A61K 9/20 (2006.01) A61K 9/00 (2006.01)

(21) International Application Number:
PCT/US2010/049971

(22) International Filing Date:
23 September 2010 (23.09.2010)

(25) Filing Language: English

(26) Publication Language: English

(30) Priority Data:
61/245,315 24 September 2009 (24.09.2009) US
61/255,582 28 October 2009 (28.10.2009) US
61/314,629 17 March 2010 (17.03.2010) US
61/358,167 24 June 2010 (24.06.2010) US
12/887,582 22 September 2010 (22.09.2010) US

(71) Applicant (for all designated States except US): MC-NEIL-PPC, INC. [US/US]; 199 Grandview Road, Skillman, NJ 08558 (US).

(72) Inventors; and

(75) Inventors/Applicants (for US only): KOLL, Gregory, E. [US/US]; 314 Thatcher Terrace, Hillsborough, NJ 08844 (US). SOWDEN, Harry, S. [US/US]; 209 Woods Road, Glenside, PA 19038 (US). LUBER, Joseph, R. [US/US]; 750 East Cherry Road, Quakertown, PA 18951 (US). KRIKSUNOV, Leo, B. [US/US]; 5 Perry Lane, Ithaca, NY 14850 (US). BUNICK, Frank, J. [US/US]; 47 Long Ridge Road, Randolph, NJ 07869 (US). CHEN, Jen-chi [US/US]; 80 Annamarie Drive, Morrisville, 19067 (US). OLSSON, Rolland [SE/SE]; Saffransgatan 5, 73, S-253 Gantofta (SE). SZYMCAK, Christopher, E. [US/US]; 70 Colts Gait Road, Marlton, NJ 08053 (US).

[Continued on next page]

(54) Title: MANUFACTURE OF CHEWING GUM PRODUCT WITH RADIOFREQUENCY

FIG. 1C

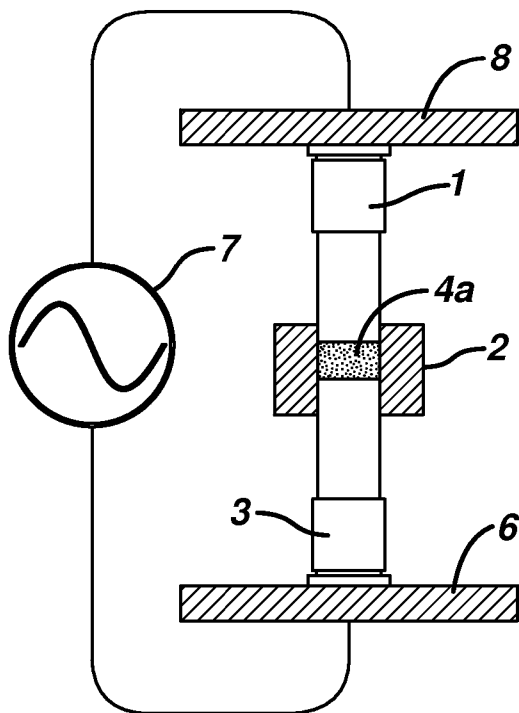

(57) Abstract: The present invention features a process for making a chewing gum product including the steps of forming a powder blend containing a gum base into the desired shape of the chewing gum product and applying radio frequency energy to the shape for a sufficient period of time to soften the gum base to fuse the shape into the chewing gum product.

WO 2011/038101 A1



(74) **Agents:** MCGOWAN, William, E. et al.; Johnson & Johnson, 1 Johnson & Johnson Plaza, New Brunswick, NJ 08933 (US).

(81) **Designated States** (unless otherwise indicated, for every kind of national protection available): AE, AG, AL, AM, AO, AT, AU, AZ, BA, BB, BG, BH, BR, BW, BY, BZ, CA, CH, CL, CN, CO, CR, CU, CZ, DE, DK, DM, DO, DZ, EC, EE, EG, ES, FI, GB, GD, GE, GH, GM, GT, HN, HR, HU, ID, IL, IN, IS, JP, KE, KG, KM, KN, KP, KR, KZ, LA, LC, LK, LR, LS, LT, LU, LY, MA, MD, ME, MG, MK, MN, MW, MX, MY, MZ, NA, NG, NI, NO, NZ, OM, PE, PG, PH, PL, PT, RO, RS, RU, SC, SD, SE, SG, SK, SL, SM, ST, SV, SY, TH, TJ, TM, TN, TR, TT, TZ, UA, UG, US, UZ, VC, VN, ZA, ZM, ZW.

(84) **Designated States** (unless otherwise indicated, for every kind of regional protection available): ARIPO (BW, GH, GM, KE, LR, LS, MW, MZ, NA, SD, SL, SZ, TZ, UG,

ZM, ZW), Eurasian (AM, AZ, BY, KG, KZ, MD, RU, TJ, TM), European (AL, AT, BE, BG, CH, CY, CZ, DE, DK, EE, ES, FI, FR, GB, GR, HR, HU, IE, IS, IT, LT, LU, LV, MC, MK, MT, NL, NO, PL, PT, RO, SE, SI, SK, SM, TR), OAPI (BF, BJ, CF, CG, CI, CM, GA, GN, GQ, GW, ML, MR, NE, SN, TD, TG).

Declarations under Rule 4.17:

- as to the identity of the inventor (Rule 4.17(i))
- as to applicant's entitlement to apply for and be granted a patent (Rule 4.17(ii))
- as to the applicant's entitlement to claim the priority of the earlier application (Rule 4.17(iii))

Published:

- with international search report (Art. 21(3))

MANUFACTURE OF CHEWING GUM PRODUCT WITH RADIOFREQUENCY

5 Cross Reference to Related Applications

This application claims priority of the benefits of the filing of U.S. Provisional Application Serial No. 61/245,315, filed September 24, 2009, U.S. Provisional Application Serial No. 61/255,582, filed October 28, 2009, U.S. Provisional Application Serial No. 61/314,629, filed March 17, 2010, and U.S. Provisional Application Serial
10 No. 61/358,167, filed June 24, 2010. The complete disclosures of the aforementioned related U.S. patent applications are hereby incorporated herein by reference for all purposes.

Background of the Invention

Chewing gums can be formed by conventional processes involving dough mixing
15 with rolling and scoring or directly compressing a compressible mixture. See WO 2006/127618. Compressed gums tend to have an undesirable texture upon placement in the mouth, in that they tend to disintegrate into granular or powdery portions which must be reintegrated into a unified gum upon chewing. Compressed gums can also be limited in the amount of gum base that can be incorporated into the form and often have limited
20 duration sensory characteristics like taste. Stick and extruded gums must be preheated before forming into the final gum. This pre-heating step can be disadvantageous for several reasons, including the potential degradation of active ingredients which are sensitive to heat and/or degradation of volatile or heat sensitive flavor components.

Thus, there is a need to manufacture gums using a powder blend containing the
25 gum base that avoids one or more of the disadvantages associated with current compressed chewing gum products.

Summary of the Invention

30 In one aspect, the present invention features a process for making a chewing gum product including the steps of forming a powder blend containing a gum base into the desired shape of the chewing gum product and applying radiofrequency ("RF") energy to

the shape for a sufficient period of time to soften the gum base to fuse the shape into the chewing gum product. One or more of the above ingredients may be present on the same particle of the powder blend.

In other aspects, the present invention features chewing gum products
5 manufactured by such process and the use of chewing gum products.

Other features and advantages of the present invention will be apparent from the detailed description of the invention and from the claims.

Brief Description of the Figures

10 FIGS. 1A-F are cross-section, side views of an embodiment of the invention showing the manufacture of chewing gum shape 4a from powder blend 4 within die platen 2.

FIGS. 2A-H are cross-section, side views of an embodiment of the invention showing the manufacture of a bilayer chewing gum 12 from powder blends 10 and 11
15 within die platen 2.

FIGS. 3A-F are cross-section, side views of an embodiment of the invention showing the manufacture of chewing gum 40 containing preformed inserts 30 and 31 from powder blend 20 within die platen 2.

FIGS. 4A and 4B are a perspective view of a rotary indexing machine 195.

20 FIGS. 5A and 5B are top views of the rotary indexing machine 195 in the dwell position.

FIGS. 6A and 6B are section views of the lower forming tool assembly 110 in the start position of the manufacturing cycle.

25 FIG. 7 is a section view through the RF station rotary indexing machine 195 prior to compacting powder blend 101.

FIG. 8 is a section view through the RF station rotary indexing machine 195 prior showing the manufacture of chewing gums 101a.

FIG. 9 is a section view through chewing gum ejection station 160 before chewing gums 101a have been ejected.

30 FIG. 10 is a section view through chewing gum ejection station 160 after chewing gums 101a have been ejected into blister 190.

FIGS. 11A-D are cross sections of alternate embodiments of forming tools and the die platen.

FIGS. 12A-D are cross sections of alternate embodiments of forming tools and the die platen.

5 FIG. 13A is a cross section of forming tools having a wave-shaped surface.

FIG. 13B is a perspective view of forming tools having a wave-shaped surface.

FIG. 14 is a cross section of forming tools having protrusions at the surface.

Detailed Description of the Invention

10 It is believed that one skilled in the art can, based upon the description herein, utilize the present invention to its fullest extent. The following specific embodiments can be construed as merely illustrative, and not limitative of the remainder of the disclosure in any way whatsoever.

Unless defined otherwise, all technical and scientific terms used herein have the
15 same meaning as commonly understood by one of ordinary skill in the art to which the invention belongs. Also, all publications, patent applications, patents, and other references mentioned herein are incorporated by reference. As used herein, all percentages are by weight unless otherwise specified.

As discussed above, in one aspect, the present invention features a process for
20 making a chewing gum product including the steps of forming a powder blend containing a gum base into the desired shape of the chewing gum product and applying radiofrequency energy to the shape for a sufficient period of time to soften the gum base to fuse the shape into the chewing gum product.

25 **Powder Blend**

As discussed above, the chewing gum shape is manufactured by compacting a powder blend containing a gum base and optionally nicotine and/or other pharmaceutically active agent(s) and/or excipients. Examples of such excipients include, but are not limited to, glidants, lubricants, sweeteners, flavors and aromatics, coloring
30 agents, preservatives, vitamins, minerals, fluoride, and tooth whitening agents, and

mixtures thereof. One or more of the above ingredients may be present on the same particle of the powder blend.

Suitable lubricants include, but are not limited to, long chain fatty acids and their salts, such as magnesium stearate and stearic acid, talc, glycerides waxes, and mixtures thereof.

Suitable glidants include, but are not limited to, colloidal silicon dioxide.

Examples of sweeteners include, but are not limited to, synthetic or natural sugars; artificial sweeteners such as saccharin, sodium saccharin, aspartame, acesulfame, thaumatin, glycyrrhizin, sucralose, dihydrochalcone, alitame, miraculin, monellin, and stevioside; sugar alcohols such as sorbitol, mannitol, glycerol, lactitol, maltitol, and xylitol; sugars extracted from sugar cane and sugar beet (sucrose), dextrose (also called glucose), fructose (also called laevulose), and lactose (also called milk sugar); isomalt, salts thereof, and mixtures thereof.

Examples of flavors and aromatics include, but are not limited to, essential oils including distillations, solvent extractions, or cold expressions of chopped flowers, leaves, peel or pulped whole fruit containing mixtures of alcohols, esters, aldehydes and lactones; essences including either diluted solutions of essential oils, or mixtures of synthetic chemicals blended to match the natural flavor of the fruit (e.g., strawberry, raspberry and black currant); artificial and natural flavors of brews and liquors, e.g., cognac, whisky, rum, gin, sherry, port, and wine; tobacco, coffee, tea, cocoa, and mint; fruit juices including expelled juice from washed, scrubbed fruits such as lemon, orange, and lime; spear mint, pepper mint, wintergreen, cinnamon, cacao/cocoa, vanilla, liquorice, menthol, eucalyptus, aniseeds nuts (e.g., peanuts, coconuts, hazelnuts, chestnuts, walnuts, colanuts), almonds, raisins; and powder, flour, or vegetable material parts including tobacco plant parts, e.g., genus *Nicotiana*, in amounts not contributing significantly to the level of nicotine, and ginger.

In one embodiment, the chewing gum may incorporate a flavor or flavoring component which is encapsulated, in order to provide a taste profile where the flavor is released upon chewing and hydration over time.

Examples of coloring agents include, but are not limited to, dyes being approved as a food additive.

Gum Base

The gum base may be of any conventional gum base known in the art. For example it may be of natural or synthetic origin. Natural gum bases include, but are not limited to, chicle, jelutong-, lechi de caspi-, soh-, siak-, katiiau-, sorwa-, balata-, pendare-, malaya-, and peach gums; natural cautchouc; and natural resins such as dammar and mastix. Other examples of gum bases include, but are not limited to, agar, alginate, arabic gum, carob gum, carrageenan, ghatti gum, guar gum, karaya gum, pectin, tragacanth gum, locust beam gum, gellan gum and xanthan gum. Synthetic gum bases typically include a mixture of elastomers such as natural latexes and synthetic rubbers, resins such as glycerol esters or gums, waxes such as paraffin, fats such as hydrogenated vegetable oils, emulsifiers such as lecithin, and/or antioxidants such as BHT.

In one embodiment, the amount of gum base in the powder blend/gum shape/chewing gum product is from about 10-80%, by weight, such as from about 20% to about 70%, such as from about 30% to about 70%, such as from about 40% to about 70%.

Nicotine Compound

In one embodiment, the powder blend/gum shape/chewing gum product contains a smoking cessation compound(s) such as: nicotine and/or metabolites thereof, such as cotinine, nicotine N'-oxide, nornicotine, (S)-nicotine-N- β -glucuronide or salt thereof (hereinafter "nicotine compound"); varenicline, bupropion, nortriptyline, doxepin, fluoxetine, imipramine, moclobemide, conotoxinMII, epibatidine, A-85380, lobeline, anabasine, SIB-1508Y, SIB-1553A, ABT-418, ABT-594, ABT-894, TC-2403, TC-2559, RJR-2403, SSR180711, GTS-21, and/or cytosine or salts thereof. The smoking cessation compound (e.g., nicotine compound) may be present in the powder blend and/or the optional coating.

Numerous nicotine salts are known and may be used. Examples include, but are not limited to, formic (2:1), acetic (3:1), propionic (3:1), butyric (3:1), 2-methylbutyric (3:1), 3-methylbutyric (3:1), valeric (3:1), lauric (3:1), palmitic (3:1), tartaric (1:1) and (2:1), citric (2:1), malic (2:1), oxalic (2:1), benzoic (1:1), gentisic (1:1), gallic (1:1), phenylacetic (3:1), salicylic (1:1), phthalic (1:1), picric (2:1), sulfosalicylic (1:1), tannic

(1:5), pectic (1:3), alginic (1:2), hydrochloric (2:1), chloroplatinic (1:1), silicotungstic (1:1), pyruvic (2:1), glutamic (1:1), and aspartic (1:1) salts of nicotine.

In one embodiment, the nicotine compound is bound to a resin (e.g., a polyacrylate resin), zeolite, or cellulose or starch microsphere. Examples of cation exchange resins include, but are not limited to, Amberlite IRC 50 (Rohm & Haas),
5 Amberlite IRP 64 (Rohm & Haas), Amberlite IRP 64M (Rohm & Haas), BIO-REX 70 (BIO-RAD Lab.), Amberlite IR 118 (Rohm & Haas), Amberlite IRP 69 (Rohm & Haas), Amberlite IRP 69M (Rohm & Haas), BIO-REX 40 (BIO-RAD Lab.), Amberlite IR 120 (Rohm & Haas), Dowex 50 (Dow Chemical), Dowex 50W (Dow Chemical), Duolite C
10 25 (Chemical Process Co.), Lewatit S 100 (Farbenfabriken Bayer), Ionac C 240 (Ionac Chem.), Wofatit KP S 200 (I.G. Farben Wolfen), Amberlyst 15 (Rohm & Haas), Duolite C-3 (Chemical Process), Duolite C-10 (Chemical Process), Lewatit KS (Farbenfabriken Bayer), Zerolit 215 (The Permutit Co.), Duolite ES-62 (Chemical Process), BIO-REX 63 (BIO-RAD Lab.), Duolite ES-63 (Chemical Process), Duolite ES-65 (Chemical Process),
15 Ohelex 100 (BIO-RAD Lab.), Dow Chelating Resin A-1 (Dow Chemical Company), Purolite C115HMR (Purolite International Ltd.), CM Sephadex C-25 (Pharmacia Fine Chemicals), SE Sephadex C-25 (Pharmacia Fine Chemicals), Viscarin GP-109NF
Lambda-carrageenan FMC Biopolymer or any other anionic polyelectrolyte.

In one another embodiment, the nicotine compound is in the form of an inclusion
20 complex with a cyclodextrin, which may include cyclodextrin complexation, such as complexation of the active pharmaceutically compound with cyclodextrin where preferably the cyclodextrin used is chosen among α -, β - and γ -cyclodextrin, the hydroxypropyl derivatives of α -, β - and γ -cyclodextrin, sulfoalkylether cyclodextrins such as sulfobutylether β -cyclodextrin, alkylated cyclodextrins such as the randomly
25 methylated β -cyclodextrin, and various branched cyclodextrins such as glucosyl- and maltosyl- β -cyclodextrin.

In one embodiment, the nicotine compound is dosed in the chewing gum product to provide the person with a dose to achieve an effect, e.g., to provide a sense of smoking satisfaction without smoking and/or to reduce of the urge to smoke or use tobacco. This
30 amount may, of course, vary from person to person.

In one embodiment, chewable gum product includes the nicotine compound in an amount of from about 0.05 to about 12 mg calculated as the free base form of nicotine per chewing gum product, such as from about 0.2-6 mg, such as from about 0.5-5 mg. This may in different embodiments include 0.05, 0.5, 1, 1.5, 2, 3, 4, 4.5, 5, 6, 7, 8, 9, 10 or 12 mg calculated as the free base form of nicotine per chewing gum product.

Buffering Agent

In one embodiment, the chewing gum/powder blend/coating contains both nicotine and a buffering agent. In one embodiment, the chewing gum is buffered such that upon administration of the chewing gum, the pH of the saliva is transiently increased from about 0.2 to about 4 pH units, preferably from about 0.4 to about 2 pH units. The buffering is designed so as to achieve a transient buffering of the saliva of a subject during mastication of the chewing gum product. As the change is transient, the pH will return to its normal value after a certain period of time.

Examples of buffering agents include, but are not limited to, carbonates including bicarbonate or sesquicarbonate, glycinate, phosphate, glycerophosphate or citrate of an alkali metal, such as potassium or sodium, or ammonium such as trisodium or tripotassium citrate, trisodium phosphate, disodium hydrogen phosphate, tripotassium phosphate, dipotassium hydrogen phosphate, calcium hydroxide, sodium glycinate, and trometamol (TRIS). Alkali metal carbonates, glycinates and phosphates are preferred buffering agents.

The one or more buffering agents may to some extent be microencapsulated or otherwise coated as granules with polymers and/or lipids being less soluble in saliva than is the one or more buffering agents. Such microencapsulation controls the dissolution rate whereby is extended the time frame of the buffering effect.

In order to increase the buffering capacity still further without correspondingly increasing the pH, one may in specific embodiments use a second or auxiliary buffering agent to the first buffering agent, such as e.g., sodium or potassium bicarbonate buffers. The second or auxiliary buffering agent may be selected from the group consisting of alkali metal bicarbonates that are preferred for this purpose. Thus, further embodiments

of the invention may include a mixture of an alkali metal carbonate or phosphate and alkali metal bicarbonate.

The amount of the buffering agent or agents in the chewing gum composition is preferably sufficient in the specific embodiments to raise the pH of the saliva to above 7, as specified above, to transiently maintain the pH of the saliva in the oral cavity above 7, e.g., pH 7-11.

The nicotine may be administered in different forms, e.g., in different complexes or salts. The amount of buffer required to achieve such an increase in pH of the different administered nicotine form is readily calculated by the skilled man in the art. The extent and duration of the increase in pH is dependent on type and amount of the buffering agent(s) used as well as where the buffer is distributed in the product.

Pharmaceutically Active Agent

The powder blend/gum shape/chewing gum product of the present invention may include at least one pharmaceutically active agent (other than or in addition to a nicotine compound). What is meant by a "pharmaceutically active agent" is an agent (e.g., a compound) that is permitted or approved by the U.S. Food and Drug Administration, European Medicines Agency, or any successor entity thereof, for the oral treatment of a condition or disease. Suitable pharmaceutically active agents include, but are not limited to, analgesics, anti-inflammatory agents, antipyretics, antihistamines, antibiotics (e.g., antibacterial, antiviral, and antifungal agents), antidepressants, antidiabetic agents, antispasmodics, appetite suppressants, bronchodilators, cardiovascular treating agents (e.g., statins), central nervous system treating agents, cough suppressants, decongestants, diuretics, expectorants, gastrointestinal treating agents, anesthetics, mucolytics, muscle relaxants, osteoporosis treating agents, stimulants, and sedatives.

Examples of suitable gastrointestinal treating agents include, but are not limited to: antacids such as aluminum-containing pharmaceutically active agents (e.g., aluminum carbonate, aluminum hydroxide, dihydroxyaluminum sodium carbonate, and aluminum phosphate), bicarbonate-containing pharmaceutically active agents, bismuth-containing pharmaceutically active agents (e.g., bismuth aluminate, bismuth carbonate, bismuth subcarbonate, bismuth subgallate, and bismuth subnitrate), calcium-containing

pharmaceutically active agents (e.g., calcium carbonate), glycine, magnesium-containing pharmaceutically active agents (e.g., magaldrate, magnesium aluminosilicates, magnesium carbonate, magnesium glycinate, magnesium hydroxide, magnesium oxide, and magnesium trisilicate), phosphate-containing pharmaceutically active agents (e.g., aluminum phosphate and calcium phosphate), potassium-containing pharmaceutically active agents (e.g., potassium bicarbonate), sodium-containing pharmaceutically active agents (e.g., sodium bicarbonate), and silicates; laxatives such as stool softeners (e.g., docusate) and stimulant laxatives (e.g., bisacodyl); H₂ receptor antagonists, such as famotidine, ranitidine, cimetadine, and nizatidine; proton pump inhibitors such as omeprazole, dexlansoprazole, esomeprazole, pantoprazole, rabeprazole, and lansoprazole; gastrointestinal cytoprotectives, such as sucralfate and misoprostol; gastrointestinal prokinetics such as prucalopride; antibiotics for *H. pylori*, such as clarithromycin, amoxicillin, tetracycline, and metronidazole; antidiarrheals, such as bismuth subsalicylate, kaolin, diphenoxylate, and loperamide; glycopyrrolate; analgesics, such as mesalamine; antiemetics such as ondansetron, cyclizine, diphenhydramine, dimenhydrinate, meclizine, promethazine, and hydroxyzine; probiotic bacteria including but not limited to lactobacilli; lactase; racecadotril; and antiflatulents such as polydimethylsiloxanes (e.g., dimethicone and simethicone, including those disclosed in United States Patent Nos. 4,906,478, 5,275,822, and 6,103,260); isomers thereof; and pharmaceutically acceptable salts and prodrugs (e.g., esters) thereof.

Examples of suitable analgesics, anti-inflammatories, and antipyretics include, but are not limited to, non-steroidal anti-inflammatory drugs (NSAIDs) such as propionic acid derivatives (e.g., ibuprofen, naproxen, ketoprofen, flurbiprofen, fenbufen, fenoprofen, indoprofen, ketoprofen, fluprofen, piroprofen, carprofen, oxaprozin, pranoprofen, and suprofen) and COX inhibitors such as celecoxib; acetaminophen; acetylsalicylic acid; acetic acid derivatives such as indomethacin, diclofenac, sulindac, and tolmetin; fenamic acid derivatives such as mefenamic acid, meclofenamic acid, and flufenamic acid; biphenylcarboxylic acid derivatives such as diflunisal and flufenisal; and oxicams such as piroxicam, sudoxicam, isoxicam, and meloxicam; isomers thereof; and pharmaceutically acceptable salts and prodrugs thereof.

Examples of antihistamines and decongestants, include, but are not limited to, bromopheniramine, chlorcyclizine, dexbrompheniramine, bromhexane, phenindamine, pheniramine, pyrillamine, thonzylamine, pripolidine, ephedrine, phenylephrine, pseudoephedrine, phenylpropanolamine, chlorpheniramine, dextromethorphan, 5 diphenhydramine, doxylamine, astemizole, terfenadine, fexofenadine, naphazoline, oxymetazoline, montelukast, propylhexadrine, triprolidine, clemastine, acrivastine, promethazine, oxomemazine, mequitazine, buclizine, bromhexine, ketotifen, terfenadine, ebastine, oxatamide, xylomeazoline, loratadine, desloratadine, and cetirizine; isomers thereof; and pharmaceutically acceptable salts and esters thereof.

10 Examples of cough suppressants and expectorants include, but are not limited to, diphenhydramine, dextromethorphan, noscapine, clophedianol, menthol, benzonatate, ethylmorphine, codeine, acetylcysteine, carbocisteine, ambroxol, belladonna alkaloids, sobrenol, guaiaicol, and guaifenesin; isomers thereof; and pharmaceutically acceptable salts and prodrugs thereof.

15 Examples of muscle relaxants include, but are not limited to, cyclobenzaprine and chlorzoxazone metaxalone, orphenadrine, and methocarbamol; isomers thereof; and pharmaceutically acceptable salts and prodrugs thereof.

Examples of stimulants include, but are not limited to, caffeine.

20 Examples of sedatives include, but are not limited to sleep aids such as antihistamines (e.g., diphenhydramine), eszopiclone, and zolpidem, and pharmaceutically acceptable salts and prodrugs thereof.

Examples of appetite suppressants include, but are not limited to, phenylpropanolamine, phentermine, and diethylcathinone, and pharmaceutically acceptable salts and prodrugs thereof

25 Examples of anesthetics (e.g., for the treatment of sore throat) include, but are not limited to dyclonine, benzocaine, and pectin and pharmaceutically acceptable salts and prodrugs thereof.

30 Examples of suitable statins include but are not limited to atorvastin, rosuvastatin, fluvastatin, lovastatin, simvastatin, atorvastatin, pravastatin and pharmaceutically acceptable salts and prodrugs thereof.

As discussed above, the pharmaceutically active agents of the present invention may also be present in the form of pharmaceutically acceptable salts, such as acidic/anionic or basic/cationic salts. Pharmaceutically acceptable acidic/anionic salts include, and are not limited to acetate, benzenesulfonate, benzoate, bicarbonate, bitartrate, bromide, calcium edetate, camsylate, carbonate, chloride, citrate, 5 dihydrochloride, edetate, edisylate, estolate, esylate, fumarate, glyceptate, gluconate, glutamate, glycollylarsanilate, hexylresorcinate, hydrabamine, hydrobromide, hydrochloride, hydroxynaphthoate, iodide, isethionate, lactate, lactobionate, malate, maleate, mandelate, mesylate, methylbromide, methylnitrate, methylsulfate, mucate, 10 napsylate, nitrate, pamoate, pantothenate, phosphate/diphosphate, polygalacturonate, salicylate, stearate, subacetate, succinate, sulfate, tannate, tartrate, teoclate, tosylate and triethiodide. Pharmaceutically acceptable basic/cationic salts include, and are not limited to aluminum, benzathine, calcium, chlorprocaine, choline, diethanolamine, ethylenediamine, lithium, magnesium, meglumine, potassium, procaine, sodium and zinc.

15 As discussed above, the pharmaceutically active agents of the present invention may also be present in the form of prodrugs of the pharmaceutically active agents. In general, such prodrugs will be functional derivatives of the pharmaceutically active agent, which are readily convertible in vivo into the required pharmaceutically active agent. Conventional procedures for the selection and preparation of suitable prodrug 20 derivatives are described, for example, in "Design of Prodrugs", ed. H. Bundgaard, Elsevier, 1985. In addition to salts, the invention provides the esters, amides, and other protected or derivatized forms of the described compounds.

Where the pharmaceutically active agents according to this invention have at least one chiral center, they may accordingly exist as enantiomers. Where the pharmaceutically 25 active agents possess two or more chiral centers, they may additionally exist as diastereomers. It is to be understood that all such isomers and mixtures thereof are encompassed within the scope of the present invention. Furthermore, some of the crystalline forms for the pharmaceutically active agents may exist as polymorphs and as such are intended to be included in the present invention. In addition, some of the 30 pharmaceutically active agents may form solvates with water (e.g., hydrates) or common

organic solvents, and such solvates are also intended to be encompassed within the scope of this invention.

In one embodiment, the pharmaceutically active agent or agents are present in the chewing gum product in a therapeutically effective amount, which is an amount that produces the desired therapeutic response upon oral administration and can be readily determined by one skilled in the art. In determining such amounts, the particular pharmaceutically active agent being administered, the bioavailability characteristics of the pharmaceutically active agent, the dose regime, the age and weight of the patient, and other factors must be considered, as known in the art.

The pharmaceutically active agent may be present in various forms. For example, the pharmaceutically active agent may be dispersed at the molecular level, e.g. melted, within the chewing gum product, or may be in the form of particles, which in turn may be coated or uncoated. If the pharmaceutically active agent is in form of particles, the particles (whether coated or uncoated) typically have an average particle size of from about 1 to about 2000 microns. In one embodiment, such particles are crystals having an average particle size of from about 1 to about 300 microns. In another embodiment, the particles are granules or pellets having an average particle size of from about 50 to about 2000 microns, such as from about 50 to about 1000 microns, such as from about 100 to about 800 microns.

The pharmaceutically active agent may be present in pure crystal form or in a granulated form prior to the addition of the taste masking coating. Granulation techniques may be used to improve the flow characteristics or particle size of the pharmaceutically active agents to make it more suitable for compaction or subsequent coating. Suitable binders for making the granulation include but are not limited to starch, polyvinylpyrrolidone, polymethacrylates, hydroxypropylmethylcellulose, and hydroxypropylcellulose. The particles including pharmaceutically active agent(s) may be made by cogranulating the pharmaceutically active agent(s) with suitable substrate particles via any of the granulation methods known in the art. Examples of such granulation method include, but are not limited to, high sheer wet granulation and fluid bed granulation such as rotary fluid bed granulation.

If the pharmaceutically active agent has an objectionable taste, the pharmaceutically active agent may be coated with a taste masking coating, as known in the art. Examples of suitable taste masking coatings are described in U.S. Patent No. 4,851,226, U.S. Patent No. 5,075,114, and U.S. Patent No. 5,489,436. Commercially available taste masked pharmaceutically active agents may also be employed. For example, acetaminophen particles, which are encapsulated with ethylcellulose or other polymers by a coacervation process, may be used in the present invention. Coacervation-encapsulated acetaminophen may be purchased commercially from Eurand America, Inc. (Vandalia, Ohio) or from Circa Inc. (Dayton, Ohio).

In one embodiment one or more pharmaceutically active agents or a portion of the pharmaceutically active agent may be bound to an ion exchange resin for the purposes of taste-masking the pharmaceutically active agent or delivering the active in a modified release manner.

The susceptibility to RF energy of the pharmaceutically active agent (e.g., to melt or degrade) can have an impact on the type of energy and/or temperature used during the heating step as well as the type of the gum base used.

In one embodiment, the processing of the chewing gum product is free of a wet or hot melt granulation step. In this embodiment, the materials are directly blended prior to the addition of heat. In one embodiment, the materials are directly blended and compressed prior to the addition of heat.

Manufacture of Chewing Gum Shape

In one embodiment, the powder blend is fed into the die of an apparatus that applies pressure to form the chewing gum shape (e.g., by light compaction such as tamping). Any suitable compacting apparatus may be used, including, but not limited to, a conventional unitary or rotary tablet press. In one embodiment, the chewing gum shape may be formed by compaction using a rotary tablet press (e.g., such as those commercially available from Fette America Inc., Rockaway, N.J. or Manesty Machines LTD, Liverpool, UK). In one embodiment, the chewing gum shape is heated after it is removed from the tablet press. In another embodiment, the chewing gum shape is heated within the tablet press.

In most thermodynamic processes or machines, the heat source and the heat sink are two distinct machines or steps requiring material to be transferred from one apparatus to the other. In the manufacture of the chewing gums of the present invention, the energy must be added to the chewing gum to achieve the binding effect and then must be
5 removed from the product to solidify and strengthen it for its final handling packaging and use. One of the unique and unanticipated attributes of one embodiment of the manufacturing process of the present invention is that heat source and heat sink are part of the same apparatus. In one embodiment, heat is added to the forming tools to achieve proper sintering at the surface as well as at the center of the chewing gum.

10 To exploit this unique thermal effect, powder blends can also be chosen for their thermal properties and thermal conductivity and specific heat such that the powder blend particles themselves become heat sinks. The desirable result of this is that the total process time can be just a few seconds and that the chewing gum does not need to be transferred from the die platen during the critical tamping and heating process. The die
15 platen can function then as a material handling apparatus as well as a thermal forming tool.

In one embodiment, the compaction step (e.g., tamping) which occurs prior to the addition of the RF energy utilizes a compaction force which is less than the force required to compress a chewable or swallowable tablet. In one embodiment, the
20 compaction force is less than about 1000 pounds per square inch (e.g., less than about 500 pounds per square inch, such as less than 200 pounds per square inch, such as less than 50 pounds per square inch). In one embodiment, the energy is applied while the powder blend is under such force.

In one embodiment, the compaction step occurs in an indexed manner, where one
25 set of chewing gums are compacted simultaneously, before rotating to another indexing station. In one embodiment, the compaction step occurs at a single indexing station and the application of RF energy occurs at a separate indexing station. In another embodiment, a third indexing station is present wherein the ejection of the chewing gum or multiple chewing gums occurs, wherein the lower forming tool is raised up through
30 and up to the surface of the die. In another embodiment the compaction step is performed through the addition of air pressure or hydraulic cylinder to the top of the

upper forming tools. In one embodiment multiple chewing gums are ejected simultaneously and separated from the surface of the indexing station and removed via a take-off bar.

In another embodiment, the chewing gum shape may be prepared by the compaction methods and apparatus described in United States Patent Application Publication No. 20040156902. Specifically, the chewing gum shape may be made using a rotary compression module including a fill zone, insertion zone, compression zone, ejection zone, and purge zone in a single apparatus having a double row die construction. The dies of the compression module may then be filled using the assistance of a vacuum, with filters located in or near each die. The purge zone of the compression module includes an optional powder blend recovery system to recover excess powder blend from the filters and return the powder blend to the dies. In one embodiment the RF energy source is projected through the die table of a rotary press into the appropriate electrode within the forming tool or the forming cavity. In one embodiment the die table is constructed of non-conductive material.

In one embodiment, the chewing gum shape is prepared by the compaction methods and apparatus described in issued U.S. Patent No. 6,767,200. Specifically, the chewing gum shape is made using a rotary compression module including a fill zone, compression zone, and ejection zone in a single apparatus having a double row die construction as shown in FIG. 6 therein. The dies of the compression module are preferably filled using the assistance of a vacuum, with filters located in or near each die.

The chewing gum shape may have one of a variety of different shapes. For example, the chewing gum shape may be shaped as a polyhedron, such as a cube, pyramid, prism, or the like; or may have the geometry of a space figure with some non-flat faces, such as a cone, truncated cone, triangle, cylinder, sphere, torus, or the like. In certain embodiments, a chewing gum shape has one or more major faces. For example, the chewing gum shape surface typically has opposing upper and lower faces formed by contact with the upper and lower forming tool faces (e.g., die punches) in the compaction machine. In such embodiments, the chewing gum shape surface typically further includes a "belly-band" located between the upper and lower faces, and formed by contact with the die walls in the compaction machine. A chewing gum shape/chewing gum may also be a

multilayer. Applicants have found that sharp edges in the tooling used to make the chewing gums can cause arcing, and thus more rounded edges may be needed.

In one embodiment, the method of producing the chewing gum shape is substantially free of the use of solvents. In this embodiment, the powder blend is substantially free of solvents, and the manufacturing process (e.g., filling process into the die) is also substantially free of solvents. Solvents may include, but are not limited to, water, organic solvents such as but not limited to alcohols, chlorinated solvents, hexanes, or acetone; or gaseous solvents such as but not limited to nitrogen, carbon dioxide or supercritical fluids.

In one embodiment a vibratory step is utilized (e.g., added after filling of the powder blend but prior to the heating or fusing step, in order to remove air from the powder blend). In one embodiment a vibration with the frequency from about 1 Hz to about 50 KHz is added with amplitude from 1 micron to 5 mm peak-to-peak to allow for the flowable powder blend to settle into the cavity of a the die platen (“forming cavity”).

In one embodiment, as shown in FIGS. 1A - 1F, a metered volume of powder blend 4 is filled into a Teflon® (or similar electrical and RF energy insulative material such as ceramic or UHMW plastic) die platen 2. Die platen 2 has forming cavity 5 with inner wall 6, upper opening 7 on the upper surface of die platen 2 (which allows powder blend 4 and upper forming tool 1 to move into the forming cavity 5), and lower opening 8 on the opposite surface of die platen 2 (which allows powder blend 4 and lower forming tool 3 to move into the forming cavity 5). Powder blend 4 may be either gravity fed or mechanically fed from a feeder (not shown). A metallic, electrically conductive lower forming tool 3 is inserted into the die platen to retain the powder blend 4, within die platen 2. A similar metallic, electrically conductive upper forming tool 1 is positioned above the die platen 2 as shown in FIG 1B. The forming tools 1 and 3, die platen 2, and powder blend 4 are then moved to a compaction and RF heating station as shown in FIG 1C to form chewing gum shape 4a.

This heating station is comprised of an RF generator 7 which produces the necessary high voltage, high frequency energy. The generator 7 is electrically connected to movable upper RF electrode plate 8 and movable lower RF electrode plate 6. As shown in FIG. 1C, at this position, the powder blend 4 is compacted between an upper

forming tool 1 and a lower forming tool 3 by pressure exerted by upper RF electrode plate 8 and lower electrode plate 6 to form chewing gum shape 4a. Chewing gum shape 4a is then exposed to RF energy from RF generator 7, which heats the gum base within chewing gum shape 4a. After the RF energy is switched off, chewing gum shape 4a
5 cools to form the chewing gum 4b. In one embodiment, as shown in FIG. 1D, chewing gum 4b is pushed by upper forming tool 1 from the die platen 2 into blister 8, which is used to package chewing gum 4b. In an alternative embodiment, as shown in FIG. 1E, chewing gum 4b is pushed from the die platen 2 by the lower forming tool 3 and guided to an ejection chute by a stationary “take-off” bar (not shown). FIG. 1F shows a 3
10 dimensional representation of the forming tools 1 and 4, die platen 2, and chewing gum 4b.

In FIGS. 2A - 2H, an alternate embodiment of the invention is shown where a multilayer chewing gum is produced. First, powder blend 10 is filled into die platen 2 as shown in FIG. 2A. Powder blend 10 is tamped or moved down into die platen 2 by
15 upper forming tool 1 as shown in FIG. 2B to form chewing gum shape 10a. Then, powder blend 11 is then filled on top of chewing gum shape 10a. The forming tools 1 and 3, die platen 2, chewing gum shape 10a and powder blend 11 are then moved to the compaction and RF heating station as shown in FIG 2E. RF heating is accomplished as described above in FIG 1C to produce multilayer chewing gum 12 as shown in FIGS. 2F
20 and 2G. While a bi-layer chewing gum is shown in the drawing, additional multiple layers can be produced by adding additional powder blends to die platen 2.

FIGS. 3A - 3G show another embodiment of the invention where preformed inserts 30 and 31 are inserted into chewing gum shape 20a as shown in FIGS. 3A - 3D. Forming tools 1 and 3, die platen 2, chewing gum shape 20, and preformed inserts 30 and
25 31 are then moved to the compaction and RF heating station as shown in FIG 3E. RF heating is accomplished as described above in FIG. 1C to produce a multi-component chewing gum 40 shown in FIGS. 2F and 2G.

FIGS. 4A and 4B show two views of a rotary indexing machine 195 which is designed to create large quantities of chewing gums. This embodiment of the invention
30 is comprised of an indexing table 170 having four sets of die platens 175 each having sixteen cavities, powder feeder 100, RF generator 150, a machine frame 140, moving RF

electrode assemblies 120 and 130, lower forming tool assembly 110, upper forming tool assembly 210, chewing gum ejection station 160, indexer drive system 180, blister package web 190, and blister lid material roll 191.

Figure 5A is a top view of the apparatus in the dwell position. Figure 5B is a top view of the apparatus as the indexing table 170 rotates between stations in direction “A”.
5 Figure 6A depicts a section view through the lower forming tool assembly 110 in a start position of the manufacturing cycle. The lower forming tools 111, which are made of an electrically conductive metallic material such as brass or stainless steel, are retained in retainer plate 112 (e.g., made of aluminum or steel). Heated block 117 is attached to the retainer plate 112 and contains fluid passages 117b. Heated (or optionally cooling) fluid
10 is circulated through the heated block 117 by connections to flexible hoses 119a and 119b which form a supply and return circuit. Heating can also be accomplished by electric cartridge heaters or other suitable means (not shown). Attached to the retainer plate are cam-follower 114 and linear bearing 113. A guide shaft 116 is fixed to indexing table
15 170. The retainer plate and forming tools 111 and are moveable up or down according to the profile of barrel cam 115 which cam follower 114 rolls upon. Also shown is die platen 171, which is made of electrical and RF energy insulative material such as Teflon, UHMW, or ceramic. This is necessary to prevent a short circuit when the electrically conductive forming tools are positioned in the RF electric field in subsequent steps. The
20 forming cavity 171a is shown empty at this stage of the process.

Figure 6B depicts a section through the powder feeder station 100 of the apparatus. In this station powdered powder blend 101 is gravity fed into die platen 171. Movable cam segment 118 is adjusted up or down in direction “B” to vary the volume of the forming cavity 171a by changing the amount that the lower forming tools 111
25 penetrate into the die platen 171. This adjustable volume feature enables the precise dose of powdered powder blend to be selected for a desired chewing gum weight. When the machine indexes out of the powder feeder station, the rim of feeder 102 scrapes against the die platen 171 to create a level powder surface relative to the surface of the die platen 171.

30 Figure 7 is a section view through the RF station of the apparatus. The RF generator 150 is depicted symbolically here. In one embodiment, the configuration of

the RF generator 150 is a free running oscillator system. It is typically composed of a power vacuum tube (such as a triode), a DC voltage source between 1000 and 8000 volts connected across the cathode and plate (anode). A tank circuit is used to impose a sinusoidal signal upon the control grid and electrodes thereby producing the necessary frequency (typically 13.56 MHZ or 27.12 MHZ) and high voltage field. An example of such RF generator 150 is the COSMOS Model C10X16G4 (Cosmos Electronic Machine Corporation, Farmingdale, NY). In another embodiment, RF energy can be provided by a 50 Ohm system composed of a waveform generator which feeds a radio frequency signal to power amplifiers which are coupled to the electrodes and the load by an impedance matching network.

In Figure 7, a lower movable RF electrode 121 is shown, movable in direction "D". It is represented in its down position. The linear movement is generated by linear actuators which are typically devices such as air cylinders or servo motors. Two air cylinders are depicted in Figure 7. Air cylinder bodies 141 and 142 apply pressure to guide rods 144 and 143. Moving platens 132 and 122 are connected to the guide rods and provide an electrically isolated mounting for electrode plates 131 and 121. RF generator 150 connects to the electrode plates 131 and 121 through wires 185 and 184. A movable upper RF electrode assembly 130, movable in direction "C", is shown in its up position. Upper forming tools 133, retainer plate 134, and heated block 135 are all attached to the movable RF electrode plate 131 and, consequently, move up and down with it. Powder blend 101 is within die platen 171.

Figure 8 is a section through the same RF station but shows the RF electrodes 131 and 121 pressing against the respective forming tool assemblies 133 and 111 to both compact and apply RF energy to powder blend 101 creating chewing gum product 101a. After application of the RF energy is stopped, the moveable RF electrode plates retract, and the indexing plate 170, die platen 171, and lower forming tool assembly 110 are indexed to the next station.

Figure 9 is a section view through the chewing gum ejection station 160. Ejector pins 161 are attached to movable plate 162 (movable in the "E" direction), which is actuated by actuator assembly 163 (for example, this can be a linear servo motor or air cylinder or other suitable actuator). Actuator rod 166 connects to the movable plate

162. Linear bearing 164 and guide rod 165 provide rigidity and support for the actuator plate 162 and prevent destructive side loads created by the ejection force from acting upon actuator 163. A blister package 190 is shown below die platen 171.

Figure 10 is a section through the same assembly after the ejector pins 161 have pushed finished chewing gums 101a through the die platen 171. This direct placement of chewing gum into blister helps prevent breakage that could occur while using typical means such as feeders or by dumping chewing gums into transport drums.

In one embodiment, a lubricant is added to forming cavity prior to the addition of the flowable powder blend. This lubricant may be a liquid or solid. Suitable lubricants include but are not limited to solid lubricants such as magnesium stearate, starch, calcium stearate, aluminum stearate and stearic acid; or liquid lubricants such as but not limited to simethicone, lecithin, vegetable oil, olive oil, or mineral oil. In certain embodiments, the lubricant is added at a percentage by weight of the chewing gum of less than 5 percent, e.g. less than 2 percent, e.g. less than 0.5 percent. In certain embodiments, the presence of a hydrophobic lubricant can disadvantageously compromise the disintegration or dissolution properties of a chewing gum. In one embodiment the chewing gum is substantially free of a hydrophobic lubricant. Hydrophobic lubricants include magnesium stearate, calcium stearate and aluminum stearate.

20 Radiofrequency Heating of Chewing Gum Shape to Form Chewing Gum

Radiofrequency heating generally refers to heating with electromagnetic field at frequencies from about 1 MHz to about 100 MHz. In one embodiment of the present invention, the RF-energy is within the range of frequencies from about 1MHz to about 100MHz (e.g., from about 5MHz to 50MHz, such as from about 10MHz to about 30MHz). The RF-energy is used to heat the gum base. The degree of compaction, the type and amount of gum base, and the amount of RF energy used can determine the hardness and/or type of chewing gum.

RF energy generators are well known in the art. Examples of suitable RF generators include, but are not limited to, COSMOS Model C10X16G4 (Cosmos Electronic Machine Corporation, Farmingdale, NY).

In one embodiment, the upper and lower forming tools serve as the electrodes (e.g., they are operably associated with the RF energy source) through which the RF energy is delivered to the chewing gum shape. In one embodiment, there is direct contact between at least one RF electrode (e.g., forming tool) and the chewing gum shape. In another embodiment, there is no contact between any of the RF electrode (e.g., forming tools) and the chewing gum shape. In one embodiment, the RF electrodes are in direct contact with the surface of the chewing gum shape when the RF energy is added. In another embodiment, the RF electrodes are not in contact (e.g., from about 1mm to about 1 cm from the surface of the chewing gum shape) during the addition of the RF energy.

In one embodiment, the RF energy is delivered while the chewing gum shape is being formed. In one embodiment, the RF energy is delivered once the chewing gum shape is formed. In one embodiment, the RF energy is delivered after the chewing gum shape has been removed from the die.

In one embodiment, the RF energy is applied for a sufficient time to soften and melt substantially all (e.g., at least 90%, such as at least 95%, such as all) of the gum base within the chewing gum shape. In one embodiment, the RF energy is applied for a sufficient time to soften and melt only a portion (e.g., less than 75%, such as less than 50%, such as less than 25%) of the gum base within the chewing gum shape, for example only on a portion of the chewing gum shape, such as the outside of the chewing gum shape.

In alternate embodiments of the invention, the forming tools can be constructed to achieve localized heating effects and can also be configured to shape the electric field that is developed across the tools. Figure 11A shows one such configuration. An RF generator 200 is connected to RF electrode plates 201 and 202. Forming tools 205 and 204 are constructed of an electrically conductive material and they have an attachment 207 and 208 which are made of electrical and RF energy insulative material such as ceramic, Teflon®, polyethylene, or high density polyethylene. Die platen 203 is also constructed of electrical and RF energy insulative material. This configuration creates greater distance between the conductive forming tools to weaken the electric field which is beneficial for producing thin chewing gums without the risk of an electric arc forming which would damage the product and tooling. Figure 11B depicts a similar

configuration but with forming tools 210 and 211 that, respectively, have a recess containing insert 213 and 212 which are made of electrical and RF energy insulative material. This geometry will produce a chewing gum with lesser heating in the area where the inserts 213 and 212 are located since the electric field is weaker due to the greater distance between the conductive portions of 211 and 210. Figure 11C is similar to Figure 11B only the geometry is reversed so the chewing gum formed by this configuration will have a greater heating effect at the center since the inserts 216 and 217 are at the periphery of respective forming tools 214 and 215. Figure 11D depicts another embodiment whereby the die platen is constructed of an electrically conductive component 221 and electrically insulating component 222, which is made of electrical and RF energy insulative material. Forming tools 219 and 218 are electrically conductive, but forming tool 218 further contains second electrically insulating component 220 around the surface of upper forming tool 218 which contact chewing gum shape 206. This configuration creates an electric field and associated zones of heating that is preferential to the conductive portions of the die platen.

Figure 12A is similar to Figure 11D except the die platen 233 in this embodiment is constructed entirely of electrically conductive material. Figures 12B and 12C depict two embodiments where the die platen comprises a respective center portion 245 and 254 that are electrically conductive and respective outer portions 244/246 and 252/253 is are made of electrical and RF energy insulative material. Figure 12B further includes insulating component 220 around the surface of lower forming tool 219. Figure 12D is a further embodiment where the forming tools 263 and 262 are made of electrical and RF energy insulative material. The die platen portions 264 and 265 are made of electrical and RF energy insulative material, but there are two respective electrically conductive portions 267 and 266 which are attached to the RF generator circuit 200. In this configuration, the electric field is applied in the horizontal direction across the chewing gum shape 206.

As described above, the distance between conductive portions of the forming tool has a strong effect on field strength and heating effect. To create a chewing gum with uniform heating and texture, a forming tool that is constructed with equidistant spacing is desirable. Figure 13A and 13B depict such a configuration. In this embodiment, a

wave-shaped forming tools 270 and 273 are shown to create a chewing gum 272 within die platen 271 with a unique appearance. The profiles of the forming tool surfaces are equidistant as shown by dimension "X".

Figure 14 is an embodiment wherein a non-uniform heating is used to manufacture chewing gum 282. In this embodiment, a chewing gum with hard and soft zones is created. The forming tools 280 and 281 are made with protrusions at the surface that create high field strength (resulting in greater heating) where they are closest together (shown by the dimension "Z") and weaker field strength (resulting in lesser heating) where they are further apart (shown by the dimension "Y").

In one embodiment, to help reduce sticking, the chewing gum is cooled within the forming cavity to cool and/or solidify the gum base. The cooling can be passive cooling (e.g., at room temperature) or active cooling (e.g., coolant recirculation cooling). When coolant recirculation cooling is used, the coolant can optionally circulate through channels inside the forming tools (e.g., punches or punch platen) and/or die or die platen (e.g., as discussed above in FIGS 6A and 6B). In one embodiment, the process uses a die platen having multiple die cavities and upper and lower punch platens having multiple upper and lower punched for simultaneous forming of a plurality of chewing gums wherein the platens are actively cooled.

In one embodiment, there is a single powder blend forming the chewing gum shape which is then heated with the RF energy. In another embodiment, the chewing gum is formed of at least two different powder blends, at least one powder blend being RF-curable and at least one formulation being not RF-curable. When cured with RF energy, such chewing gum shape develops two or more dissimilarly cured zones. In one embodiment, the outside area of the chewing gum shape is cured, while the middle of the chewing gum shape is not cured. By adjusting the focus of the RF heating and shape of the RF electrodes, the heat delivered to the chewing gum shape can be focused to create customized softer or harder areas on the finished chewing gum.

In one embodiment the RF energy is combined with a second source of heat including but not limited to infrared, induction, or convection heating. In one embodiment, the addition of the second source of heat is particularly useful with a secondary non-RF-meltable binder present in the powder blend.

Microwave Heating of Chewing Gum Shape to Form Chewing Gum

In one embodiment, microwave energy is used in place of radiofrequency energy to manufacture the chewing gum. Microwave heating generally refers to heating with
5 electromagnetic field at frequencies from about 100 MHz to about 300 GHz. In one embodiment of the present invention, the RF-energy is within the range of frequencies from about 500 MHz to about 100GHz (e.g., from about 1GHz to 50GHz, such as from about 1GHz to about 10GHz). The microwave energy is used to heat the gum base In such an embodiment, a microwave energy source and microwave electrodes are used in
10 the machine used to manufacture the dosage form.

Surface Treating of the Chewing Gum Product

In one embodiment, the surface of the chewing gum shape and/or the chewing gum product is further treated with energy (e.g., convection, infrared, or RF energy) to
15 soften or melt the material on the surface of the chewing gum product and then cooled or allowed to cool to further smooth the texture, enhance the gloss of surface of the chewing gum product, limit the friability of the chewing gum product, and/or provide a mark for identification. In one embodiment, the surface of the chewing gum product is further exposed to infrared energy wherein the majority (at least 50 percent, such as least 90
20 percent, such as at least 99 percent) of the wavelength of such infrared energy is from about 0.5 to about 5 micrometers such as from about 0.8 to about 3.5 micrometers (e.g., by use of a wavelength filter). In one embodiment, the infrared energy source is a quartz lamp with a parabolic reflector (e.g., to intensify the energy) and a filter to remove unwanted frequencies. Examples of such infrared energy sources include the SPOT IR
25 4150 (commercially available from Research, Inc., Eden Prairie, MN).

Coating of the Chewing Gum Product

In one embodiment, the chewing gum product further includes at least one coating
30 layer (e.g., to add crispiness, enhance taste, or protect the gum during storage). Examples

of such coatings include, but are not limited to, sugar coatings, film coatings, press/compression coatings, or melt coatings.

For film and sugar coatings, the coating may be manually placed or sprayed onto the chewing gum product in rotating pans of different shapes or fluidized beds.

5 Sugar coating is a multistep process and may be divided into the following steps: (i) sealing of the chewing gum product; (ii) subcoating; (iii) smoothing or glossing; (iv) coloring; (v) polishing; and (vi) optionally printing. Sugar coated gums have a smoother profile with less visible edges remaining from the original core. Sub-coating, e.g., either by dusting with powder on the polyol solution or application of dry powder in the polyol
10 solution, may be used. The chewing gum product may also be coated by a panning technique, e.g., using a sugar coating pan, or other more sophisticated techniques capable of some degree of automation. The sugar in a sugar coating may be sucrose or other types of sugar, such as sugar alcohols, and/or an artificial sweetener.

Film coating involves the deposition, usually by a spray method, of a thin film of
15 polymer surrounding the chewing gum product. The solution may be sprayed on to a rotated, mixed bed. The drying conditions permit the removal of the solvent so as to leave a thin deposition of coating material around each chewing gum product.

Press coating involves the compaction of granular material around an already
manufactured core.

20

Inserts within Compacted Gum Shape

In one embodiment, an insert is incorporated into the compacted gum shape before the energy is delivered. Examples include solid compressed forms or beads filled with a liquid composition.

25 In one embodiment, the nicotine compound and/or other pharmaceutically active agent is in the form of a gel bead, which is liquid filled or semi-solid filled. The gel bead(s) are added as a portion of the powder blend. In one embodiment, the chewing gum product of this invention has the added advantage of not requiring a strong compaction step, allowing for the use of liquid or semisolid filled particles or beads which are
30 deformable since they will not rupture following the reduced pressure compaction step. These bead walls may contain gelling substances such as: gelatin; gellan gum; xanthan

gum; agar; locust bean gum; carrageenan; polymers or polysaccharides such as but not limited to sodium alginate, calcium alginate, hypromellose, hydroxypropyl cellulose and pullulan; polyethylene oxide; and starches. The bead walls may further contain a plasticizer such as glycerin, polyethylene glycol, propylene glycol, triacetin, triethyl
5 citrate and tributyl citrate. The pharmaceutically active agent may be dissolved, suspended or dispersed in a filler material such as but not limited to high fructose corn syrup, sugars, glycerin, polyethylene glycol, propylene glycol, or oils such as but not limited to vegetable oil, olive oil, or mineral oil.

In one embodiment, the insert is substantially free of RF-absorbing ingredients, in
10 which case application of the RF energy results in no significant heating of the insert itself. In other embodiments, the insert contains ingredients and are heated upon exposure to RF energy and, thus, such inserts can be used to melt/soften the gum base.

Multi-Layer Chewing Gum

15 In certain embodiments, the chewing gum includes at least two layers, e.g., with different types and/or concentrations of gum bases and/or other ingredients or different concentrations of pharmaceutically active agents. Such an embodiment is shown in FIGS. 2A-2D. In one embodiment, the chewing gum is a bilayer form; wherein the first layer is a chewing gum form and the second layer is an orally disintegrating tablet form.

20 In one embodiment the first layer is a chewing gum form and the second layer is a lozenge form. In one embodiment, the powder blend that makes up the lozenge layer contains at least one amorphous carbohydrate polymer. What is meant by an “amorphous carbohydrate polymer” is a molecule having a plurality of carbohydrate monomers wherein such molecule has a crystallinity of less than 20%, such as less than 10%, such
25 as less than 5%. Examples of amorphous carbohydrate polymers include, but are not limited to hydrogenated starch hydrolysate, polydextrose, and oligosaccharides. Examples of oligosaccharides include, but are not limited to, fructo-oligosaccharide, galacto-oligosaccharide malto-oligosaccharide, inulin, and isolmalto-oligosaccharide. In one embodiment, the amount of amorphous carbohydrate polymer in the powder blend
30 that is used to make the lozenge layer is from about 50 percent to about 99.9 percent, by weight, such as from about 80 percent to about 95 percent by weight. In one embodiment

the powder blend/lozenge shape/lozenge product contains less than about 20 percent by weight of crystalline material, such as less than 10 percent, such as less than 5 percent, such as none. In one embodiment the powder blend that is used to make the lozenge layer is substantially free of isomalt. In one embodiment the lozenge form layer is free of a material that reacts to RF heating.

In one embodiment, the lozenge form layer or the orally disintegrating tablet form layer is first compressed as a layer, then the powder blend is added to the compressed lozenge or compressed orally disintegrating tablet layer and the entire form is energized utilizing RF energy. In one embodiment, the lozenge layer or the orally disintegrating tablet layer includes at least one material that reacts to RF heating, such as a RF heatable meltable binder or a RF heatable sugar or sugar alcohol. RF heatable sugars include but are not limited to polydextrose and polyfructose. In one embodiment the lozenge powder blend or the orally disintegrating tablet blend is added to the die, then the powder blend is added to the die, and the entire form is energized utilizing RF energy. In another version of this embodiment, the order of addition of the powder blend and the lozenge powder blend or orally disintegrating tablet powder blend into the RF apparatus is reversed.

Use of Chewing Gum Product

In one embodiment, the chewing gum product does not contain a nicotine compound or a pharmaceutically active agent, and is a product is a non-medicated chewing gum used just for the chewing enjoyment of the user. In one embodiment, the present invention features a method of treating an ailment, the method including orally administering the above-described wherein the chewing gum product includes an amount of the nicotine compound and/or pharmaceutically active agent effective to treat the ailment. Examples of such ailments include, but are not limited to, pain (such as headaches, migraines, sore throat, cramps, back aches and muscle aches), fever, inflammation, upper respiratory disorders (such as cough and congestion), infections (such as bacterial and viral infections), depression, diabetes, obesity, cardiovascular disorders (such as high cholesterol, triglycerides, and blood pressure), gastrointestinal disorders (such as nausea, diarrhea, irritable bowel syndrome and gas), sleep disorders,

osteoporosis, and nicotine and/or tobacco dependence.

In this embodiment, the “unit dose” is typically accompanied by dosing directions, which instruct the patient to take an amount of the pharmaceutically active agent that may be a multiple of the unit dose depending on, e.g., the age or weight of the patient. Typically the unit dose volume will contain an amount of pharmaceutically active agent that is therapeutically effective for the smallest patient. For example, suitable unit dose volumes may include one chewing gum product.

Examples

Specific embodiments of the present invention are illustrated by way of the following examples. This invention is not confined to the specific limitations set forth in these examples.

Example 1: Preparation of Placebo Chewing Gum Product

The powder blend of Table 1 is prepared as follows. The colorant, flavor, acesulfame K, and sucralose are manually passed through a 50 mesh screen. The above mixture and remaining materials are added to a plastic bottle, mixed end-over end for approximately three minutes, and then discharged. The powder blend is then individually dosed into an electrically insulative Teflon die platen having a cavity that is 1/2 inch in diameter. 1 mm thick Teflon discs are placed between the powder blends and the metal forming tools to help prevent arcing. The powder blend is then tamped between an upper and lower metal forming tools at about 60 psi of pressure. The forming tools, die platen and chewing gum shape are then placed between the upper RF electrode and lower RF electrode powered by an RF heating unit using a COSMOS Model C10X16G4 (Cosmos Electronic Machine Corporation, Farmingdale, NY) RF generator having an output of 4 KW of power, frequency of 27 MHz, and the vacuum capacitor is set at 140. The forming tools are heated with recirculating water at a temperature of 57°C. The upper RF electrode is brought into contact with the upper forming tool and the lower RF electrode is brought into contact with lower forming tool. The RF heating unit is energized for 2-5 seconds. The resulting chewing gum product is then ejected from the die platen using the lower forming tool.

Table 1

<u>Material</u>	<u>G/Batch</u>	<u>mg/gum</u>	<u>Weight %</u>
HiG PWD-03 Gum Base ¹	97.01	970.05	97.01
Blue Lake Colorant	0.02	0.20	0.02
Vanilla-Mint Flavor	1.00	10.00	1.00
Peppermint Flavor	0.50	5.00	0.50
Sodium Bicarbonate Anhydrous	0.50	5.00	0.50
Acesulfame K	0.20	2.00	0.20
Sucralose Powder	0.40	4.00	0.40
Amorphous Silica	0.38	3.75	0.38
TOTAL	100.0	1000.00	100.0

- 5 1: Commercially available from the Cafosa Corporation in Barcelona, Spain (comprises gum base, isomalt, sorbitol and an anticaking agent).

Example 2a: Preparation of Coated Taste-Masked Dextromethorphan

10

Part I: Preparation of Layered Active Ingredient

An aqueous solution is prepared containing the following ingredients: (i) 20% dextromethorphan hydrobromide; (ii) 1% polyvinyl pyrrolidone (K29/32 grade); and (iii) 79% purified water. Then, 1.96 kg of microcrystalline cellulose (Avicel PH 200 Grade, commercially available from FMC Corporation) is charged into a fluidized bed coating apparatus (Glatt Model GPCG 5/9) fitted with a rotor (tangential spray) attachment. The microcrystalline cellulose is fluidized at an air flow at 36°C and the above aqueous solution is sprayed at a rate of 80 g/minute until the microcrystalline cellulose contains, by weight of the layered particles, approximately 40% by weight of dextromethorphan hydrobromide.

15

20

Part II: Preparation of Coated Active Ingredient

A coating solution is prepared containing cellulose acetate 398-10 (commercially available from Eastman Chemical) and basic butylated methacrylate copolymer (Eudragit E-100, commercially available from Rohm Pharma) at a level of about 12% solids at a ratio of 80:20 Cellulose Acetate:Eudragit in acetone (total solution weight equal to 10.7 kg).

A 3.0 kg portion of the particles prepared in Part I are charged into the rotor fluidized bed coating apparatus (Glatt Model GPCG 5/9). The drug-layered particles are fluidized at 36°C and the polymer solution is sprayed on at a rate of 40 g/minute until the drug particles contain approximately 20% by weight of the polymer coating.

Example 2b: Preparation of Chewing Gum Product Containing Coated Dextromethorphan

The powder blend of Table 2 is prepared as follows. The colorant, flavor, acesulfame K, and sucralose are manually passed through a 50 mesh screen. The above mixture and remaining materials including the coated dextromethorphan are added to a plastic bottle, mixed end-over end for approximately three minutes, and then discharged. The powder blend is then placed into the forming cavity, tamped, and activated with RF energy as described in Example 1 to form the chewing gum and subsequently removed from the die platen.

Table 2

<u>Material</u>	<u>G/Batch</u>	<u>mg/gum</u>	<u>Weight %</u>
HiG PWD-03 Gum Base	87.96	879.65	87.96
Coated Dextromethorphan (32%)	9.04	90.40	9.04
Blue Lake Colorant	0.02	0.20	0.02
Vanilla-Mint Flavor	1.00	10.00	1.00
Peppermint Flavor	0.50	5.00	0.50
Sodium Bicarbonate Anhydrous	0.50	5.00	0.50
Acesulfame K	0.20	2.00	0.20
Sucralose Powder	0.40	4.00	0.40

Amorphous Silica	0.38	3.75	0.38
TOTAL	100.0	1000.00	100.0

Example 3: Preparation of Chewing Gum Product Containing Nicotine Bitartrate Dihydrate

- 5 The powder blend of Table 3 is prepared as follows. The colorant, flavor, acesulfame K, and sucralose are manually passed through a 50 mesh screen. The above mixture and remaining materials including the nicotine bitartrate dihydrate and the L-Arginine are added to a plastic bottle, mixed end-over end for approximately three minutes, and then discharged. The powder blend is then placed into the forming cavity,
- 10 tamped, and activated with RF energy as described in Example 1 to form the chewing gum and subsequently removed from the die platen.

Table 3

<u>Material</u>	<u>G/Batch</u>	<u>mg/gum</u>	<u>Weight %</u>
HiG PWD-03 Gum Base	92.63	926.3	92.63
Nicotine Bitartrate Dihydrate (32.55% Nicotine)	0.615	6.15*	0.615
Blue Lake Colorant	0.02	0.2	0.02
Vanilla-Mint Flavor	1	10	1
Peppermint Flavor	0.5	5	0.5
L-arginine	4.26	42.6	4.26
Acesulfame K	0.2	2	0.2
Sucralose Powder	0.4	4	0.4
Amorphous Silica	0.375	3.75	0.375
TOTAL	100	1000	100

- 15 *Equivalent to a 2.0 mg Dose of Nicotine

Example 4: Preparation of Chewing Gum Product Containing Nicotine Resin Complex

The powder blend of Table 4 is prepared as follows. The colorant, flavor, acesulfame K, and sucralose are manually passed through a 50 mesh screen. The above

mixture and remaining materials including the nicotine resin complex and the Trometamol are added to a plastic bottle, mixed end-over end for approximately three minutes, and then discharged. The powder blend is then individually dosed into an electrically-insulative Teflon die platen and heated as set forth in Example 1. The
 5 resulting chewing gum product is then ejected from the die platen using the lower forming tool.

Table 4

<u>Material</u>	<u>G/Batch</u>	<u>mg/gum</u>	<u>Weight %</u>
HiG PWD-03 Gum Base	92.72	927.2	92.72
Nicotine Resin Complex (20% Nicotine) ¹	1	10	1
Trometamol	3.3	33	3.3
Vanilla-Mint Flavor	1	10	1
Peppermint Flavor	0.5	5	0.5
Sodium Bicarbonate Anhydrous	0.5	5	0.5
Acesulfame K	0.2	2	0.2
Sucralose Powder	0.4	4	0.4
Amorphous Silica	0.38	3.8	0.38
TOTAL	100	1000	100

10 ¹ Nicotine Polacrilex Resin commercially available from Nicrobrand, Coleraine, Co Londonderry, Northern Ireland

Example 5: Preparation of Bi-Layer Chewing Gum Product

The powder blend of Table 5a is prepared as follows (“Gum Powder Blend”).
 15 The colorant, flavor, acesulfame K, and sucralose are manually passed through a 50 mesh screen. The above mixture and remaining materials including the nicotine resin complex and the sodium bicarbonate and sodium carbonate are added to a plastic bottle, mixed end-over-end for approximately three minutes, and then discharged.

Table 5a

<u>Material</u>	<u>G/Batch</u>	<u>mg/gum</u>	<u>Weight %</u>
HiG PWD-03 Gum Base	97.61	976.10	97.61
Nicotine Resin Complex (20% Nicotine)	1.00	10.00	1.00
Sodium Bicarbonate USP	0.25	2.50	0.25
Sodium Carbonate, Anhydrous	0.50	5.00	0.50
D&C Red Lake #7 Colorant	0.04	0.40	0.04
Acesulfame K	0.20	2.00	0.20
Sucralose Powder	0.40	4.00	0.40
TOTAL	100.0	1000.00	100.0

The powder blend of Table 5b (“Isomalt Powder Blend”) is prepared by adding
5 the Galen IQ, the cinnamon, the sucralose and the sodium stearyl fumarate into a plastic
bottle and mixing end-over-end for approximately 3 minutes and then discharged.

Table 5b

<u>Material</u>	<u>G/Batch</u>	<u>mg/gum</u>	<u>Weight %</u>
Galen IQ 720 Directly Compressible Isomalt ¹	89.30	267.90	89.30
Spray Dried Cinnamon Flavor	10.00	30.00	10.00
Sucralose	0.20	0.60	0.20
Sodium Stearyl Fumarate	0.50	1.50	0.50
TOTAL	100.0	300.00	100.0

10 1: Commercially available from the BENEOPalatin GmbH Corporation in Manheim,
Germany

300 mg of the Isomalt Powder Blend is added to the die and compressed at
approximately 5 kP. Then, 1000 mg of the Gum Powder Blend is then added to the
15 compacted isomalt layer within the die, compacted, and activated utilizing RF energy as
set forth in Example 1 for 90 seconds to sinter the isomalt layer and the gum blend into a

unified bilayer dosage form. The bilayer chewing gum product is then ejected from the die.

Example 6. Preparation of Chewing Gum Product Containing Nicotine Resin Complex with Gum Base Content of 50%.

The powder blends of Table 6 are prepared as follows. Isomalt, Sodium carbonate anhydrous, Sodium hydrogen carbonate, Acesulfame Potassium, Sucralose, flavor in powder form and Magnesium oxide are sieved and loaded to a powder mixer together with the Nicotine Resin. The raw materials are then mixed together to form a powder
 10 pre-mix. The gum base is milled together with amorphous silica, and passed through a 1 mm screen. The milled gum base and amorphous silica are then added to the powder pre-mix and mixed to form a homogenous distribution of the ingredients. Finally, the magnesium stearate is added and mixed for a few minutes. The powder blend is then
 15 individually dosed into an electrically-insulative Teflon die platen and heated as set forth in Example 1. The resulting chewing gum product is then ejected from the die platen using the lower forming tool.

Table 6

	0 mg Unit Formula (mg)	0.5 mg Unit Formula (mg)	1 mg Unit Formula (mg)	2 mg Unit Formula (mg)	3 mg Unit Formula (mg)	4 mg Unit Formula (mg)
Nicotine Resin Complex 20%	0	2.5	5	10	15	20
Chewing Gum Base	500	500	500	500	500	500
Isomalt	362	359.5	357	352	347	342
Sorbitol	50	50	50	50	50	50
Flavor Powder Form	30	30	30	30	30	30
Sodium Bicarbonate	20	20	15	10	5	-
Sodium Carbonate	10	10	15	20	25	30
Magnesium Stearate	15	15	15	15	15	15
Magnesium Oxide	5	5	5	5	5	5
Acesulfame K	2	2	2	2	2	2
Amorphous Silica	5	5	5	5	5	5
Sucralose	1	1	1	1	1	1

Example 7. Preparation of Chewing Gum Product Containing Nicotine Resin Complex with Gum Base Content >20%.

The powder blends of Table 7 are prepared as follows. The Chewing Gum Base, Sodium carbonate anhydrous, Sodium hydrogen carbonate, Acesulfame Potassium, Sucralose and Magnesium oxide are sieved and loaded to a powder mixer together with the encapsulated flavors and Nicotine Resin. The raw materials are then mixed together to form a homogenous distribution of the ingredients, finally the magnesium stearate is added and mixed for a few minutes. The powder blend is then individually dosed into an electrically-insulative Teflon die platen and heated as set forth in Example 1. The resulting chewing gum product is then ejected from the die platen using the lower forming tool.

TABLE 7

	0 mg Unit Formula (mg)	0.5 mg Unit Formula (mg)	1 mg Unit Formula (mg)	2 mg Unit Formula (mg)	3 mg Unit Formula (mg)	4 mg Unit Formula (mg)
Nicotine Resin Complex 20%	0	2.5	5	10	15	20
Chewing Gum Base for Compression (HiG PWD-03)	905	902.5	900	895	890	885
Encapsulated Flavors	40	40	40	40	40	40
Sorbitol	50	50	50	50	50	50
Sodium Bicarbonate	20	20	15	10	5	-
Sodium Carbonate	10	10	15	20	25	30
Magnesium Stearate	15	15	15	15	15	15
Magnesium Oxide	5	5	5	5	5	5
Acesulfame K	2	2	2	2	2	2
Potassium Sucralose	3	3	3	3	3	3

Example 8: Preparation of Bi-Layer Chewing Gum Cinnamon Product with Crispy Polydextrose Layer

The powder blend of Table 8a is prepared as follows (“Gum Powder Blend”). The colorant, flavor, acesulfame K, and sucralose are manually passed through a 50 mesh screen. The above mixture and remaining materials including the nicotine resin complex and the sodium bicarbonate and sodium carbonate are added to a plastic bottle, mixed
 5 end-over-end for approximately three minutes, and then discharged.

Table 8a

<u>Material</u>	<u>G/Batch</u>	<u>mg/gum</u>	<u>Weight %</u>
HiG PWD-03 Gum Base	97.51	975.10	97.51
Nicotine Resin Complex (20% Nicotine)	1.10	11.00	1.10
Sodium Bicarbonate USP	0.25	2.50	0.25
Sodium Carbonate Anhydrous	0.50	5.00	0.50
D&C Red Lake #7 Colorant	0.04	0.40	0.04
Acesulfame K	0.20	2.00	0.20
Sucralose Powder	0.40	4.00	0.40
TOTAL	100.0	1000.00	100.0

The polydextrose powder blend of Table 8b is prepared by adding the
 10 polydextrose, the cinnamon, the sucralose and the sodium stearyl fumarate into a plastic bottle and mixing end-over-end for approximately 3 minutes and then discharged.

Table 8b

<u>Material</u>	<u>G/Batch</u>	<u>mg/gum</u>	<u>Weight %</u>
Polydextrose ^{1, 2}	89.30	267.90	89.30
Spray Dried Cinnamon flavor	10.00	30.00	10.00
Sucralose	0.20	0.60	0.20
Sodium Stearyl Fumarate	0.50	1.50	0.50
TOTAL	100.0	300.00	100.0

15 1: Commercially available from Danisco, Denmark
 2: Polydextrose may be exchanged for Hydrogenated starch hydrolysate or cornstarch.

300 mg of the Polydextrose powder blend is added to the die, tamped, and optionally compressed at approximately 5 kP. Then, 1000 mg of the Gum Powder Blend is then added to the compacted polydextrose layer within the die. The powder blend is then individually dosed into an electrically-insulative Teflon die platen and heated as set forth in Example 1. The resulting chewing gum product is then ejected from the die platen using the lower forming tool.

Example 9: Preparation of Bi-Layer Chewing Mint Gum Product with Crispy

10 Polydextrose layer

The powder blend of Table 9a is prepared as follows (“Gum Powder Blend”). The flavor, acesulfame K, and sucralose are manually passed through a 50 mesh screen. The above mixture and remaining materials including the nicotine resin complex and the sodium bicarbonate and sodium carbonate are added to a plastic bottle, mixed end-over-end for approximately three minutes, and then discharged.

Table 9a

<u>Material</u>	<u>G/Batch</u>	<u>mg/gum</u>	<u>Weight %</u>
HiG PWD-03 Gum Base	97.51	975.10	97.51
Nicotine Resin Complex (20% Nicotine)	1.10	11.00	1.10
Sodium Bicarbonate USP	0.25	2.50	0.25
Sodium Carbonate, Anhydrous	0.50	5.00	0.50
Mint	0.04	0.40	0.04
Acesulfame K	0.20	2.00	0.20
Sucralose Powder	0.40	4.00	0.40
TOTAL	100.0	1000.00	100.0

The polydextrose powder blend of Table 9b is prepared by adding the polydextrose, the flavor, the sucralose and the sodium stearyl fumarate into a plastic bottle and mixing end-over-end for approximately 3 minutes and then discharged.

5

Table 9b

<u>Material</u>	<u>G/Batch</u>	<u>mg/gum</u>	<u>Weight %</u>
Polydextrose	89.30	267.90	89.30
Spray Dried Mint Flavor	10.00	30.00	10.00
Sucralose	0.20	0.60	0.20
Sodium Stearyl Fumarate	0.50	1.50	0.50
TOTAL	100.0	300.00	100.0

300 mg of the Polydextrose powder blend is added to the die, tamped, and optionally compressed at approximately 5 kP. Then, 1000 mg of the Gum Powder Blend is then added to the compacted polydextrose layer within the die. The powder blend is then individually dosed into an electrically-insulative Teflon die platen and heated as set forth in Example 1. The resulting chewing gum product is then ejected from the die platen using the lower forming tool.

It is understood that while the invention has been described in conjunction with the detailed description thereof, that the foregoing description is intended to illustrate and not limit the scope of the invention, which is defined by the scope of the appended claims. Other aspects, advantages, and modifications are within the claims.

What is claimed is:

20

Claims

1. A process for making a chewing gum product, said method comprising the
5 steps of forming a powder blend comprising a gum base into the desired shape of said
chewing gum product and applying radiofrequency energy to said shape for a sufficient
period of time to soften said gum base to fuse said shape into said chewing gum product.

2. The process of claim 1, wherein said powder blend is compacted in a die
10 platen.

3. The process of claim 2, wherein said RF energy is applied to said shape
within said die platen.

4. The process of claim 1, wherein said RF energy has a frequency of from
15 about 1 MHz to 100 MHz.

5. The process of claim 1, wherein said powder blend comprises nicotine or a
salt thereof.
20

6. The process of claim 1, wherein said powder blend comprises a
pharmaceutically active agent.

7. The process of claim 1, wherein said powder blend comprises from about
25 30 to about 70 percent, by weight, of said gum base.

8. The process of claim 1, wherein said powder blend comprises from about
40 to about 70 percent, by weight, of said gum base.

9. The process of claim 1, wherein said process further comprises coating
30 said chewing gum product.

10. The process of claim 1, wherein said process further comprises adding a second powder blend to said forming cavity wherein said second powder blend is different from said powder blend.

5

11. The process of claim 10, wherein said second powder blend comprises an amorphous carbohydrate polymer.

12. The process of claim 2, wherein said process comprises the steps of:

(i) introducing said powder blend into a forming cavity within said die platen;

10

(ii) compacting said powder blend by introducing at least one forming tool into said die platen with sufficient force such that the shape of the chewing gum product is formed;

(iii) applying said radiofrequency energy to said shape, within said forming cavity to form said chewing gum product; and

15

(iv) removing said chewing gum product from said forming cavity.

13. The process of claim 12, wherein said process further comprises the step of cooling said chewing gum product in said die prior to removing said chewing gum product from said die.

20

14. The process of claim 12, wherein said at least one said forming tool emits said radiofrequency energy to said shape.

15. The process of claim 12, wherein the die platen emits said radiofrequency energy to said shape.

25

16. The process of claim 12, wherein said powder blend is compacted using an upper forming tool and a lower forming tool, and at least one of said upper forming tool or lower forming tool emits said radiofrequency energy to said shape.

30

17. The process of claim 12 wherein said process further comprises adding a second powder blend to said forming cavity prior to said step of applying radiofrequency energy to shape, wherein said second powder blend is different from said powder blend.

5 18. The process of claim 1, wherein the surface of said chewing gum product is further exposed to infrared energy wherein the majority of the wavelength of said infrared energy from about 0.5 to about 5 micrometers.

10 19. A chewing gum product manufactured according to the process of claim 1.

20. A chewing gum product of claim 19, wherein said chewing gum product comprises nicotine or a salt thereof.

15 21. A method of treating nicotine or tobacco dependence, said method comprising administering to a patient in need to such treatment the chewing gum product of claim 20.

FIG. 1A

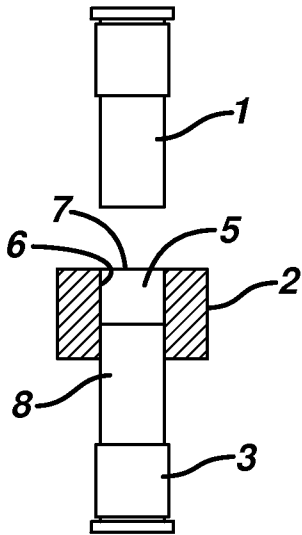

FIG. 1B

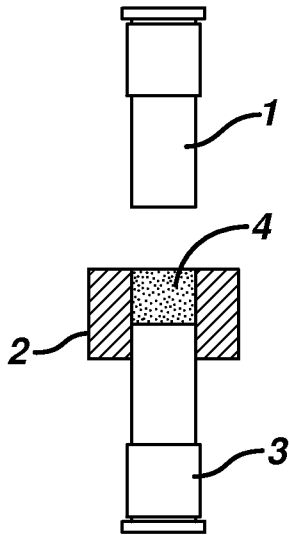

FIG. 1C

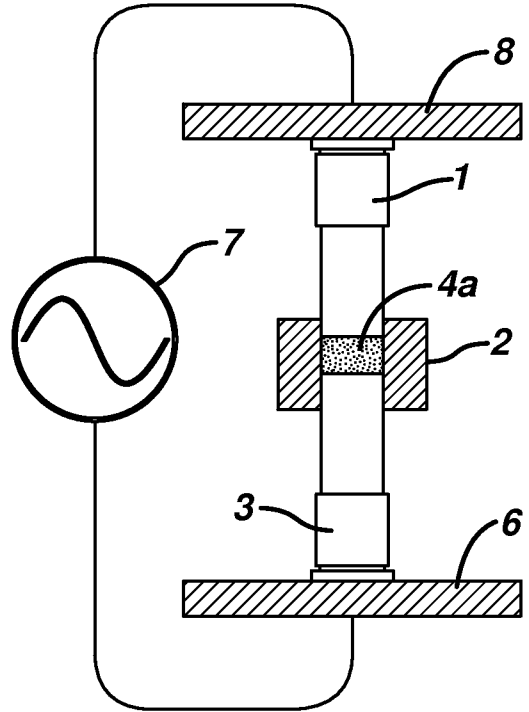

FIG. 1D

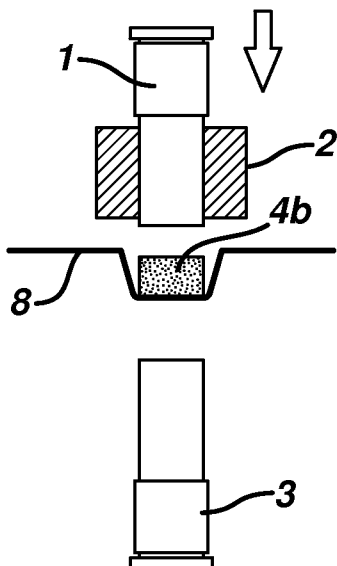

FIG. 1E

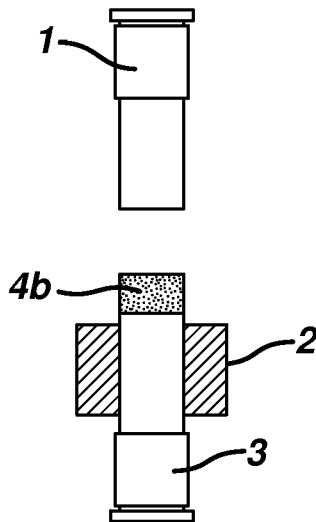

FIG. 1F

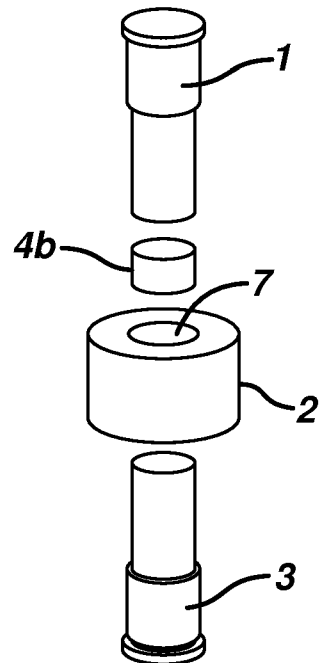

FIG. 2E

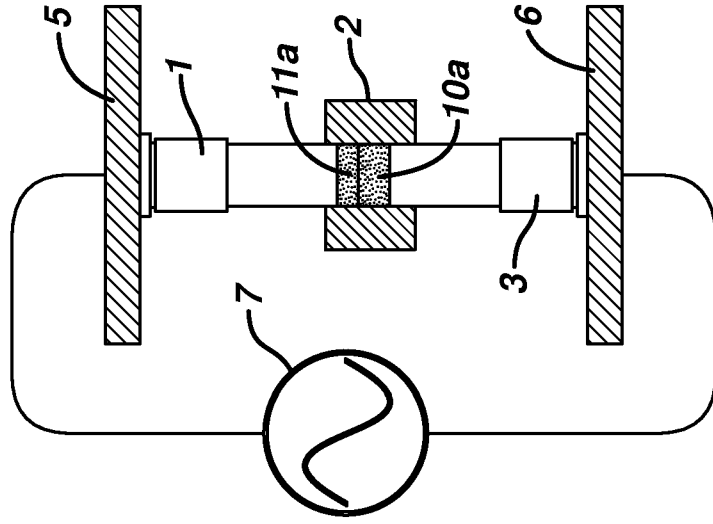

FIG. 2D

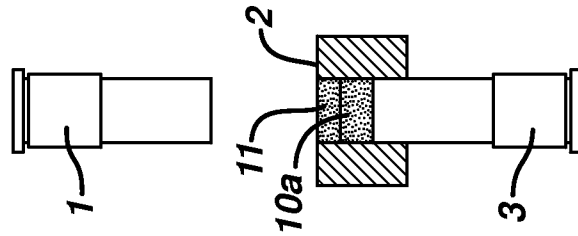

FIG. 2C

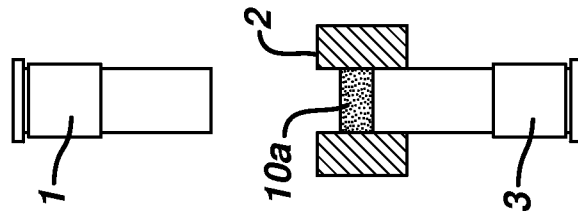

FIG. 2B

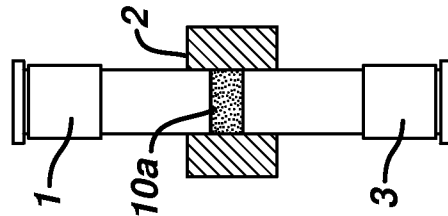

FIG. 2A

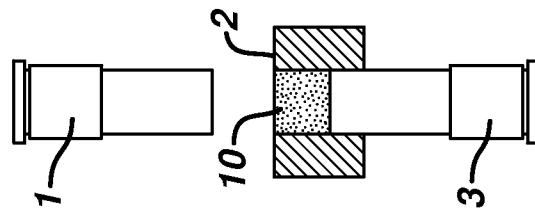

FIG. 2F

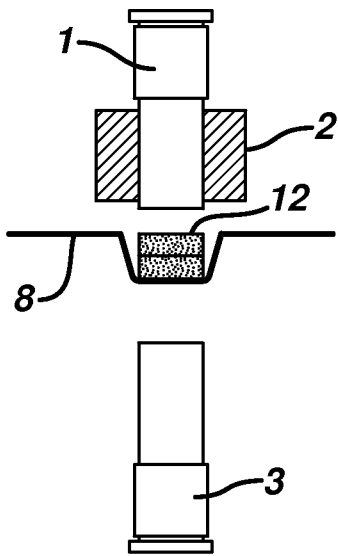

FIG. 2G

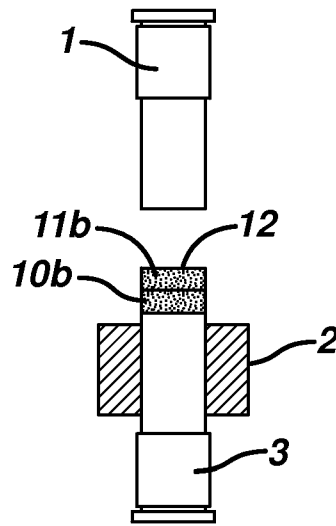

FIG. 2H

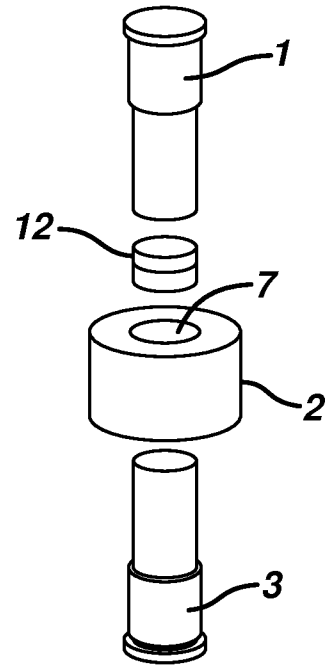

FIG. 3E

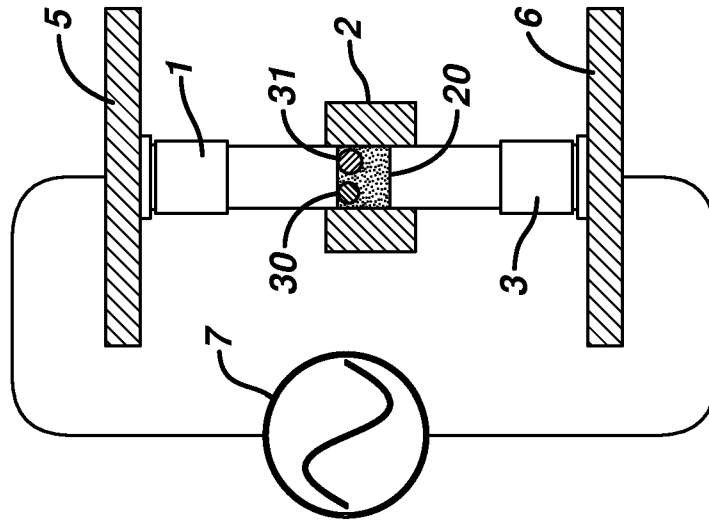

FIG. 3D

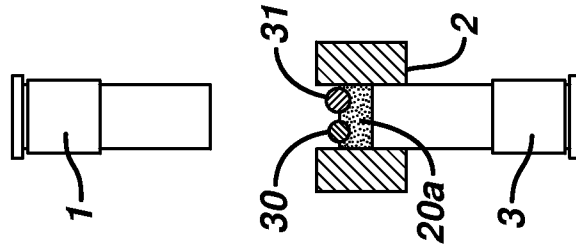

FIG. 3C

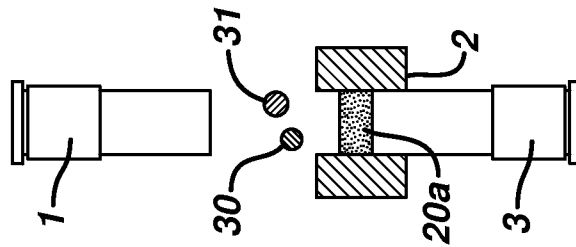

FIG. 3B

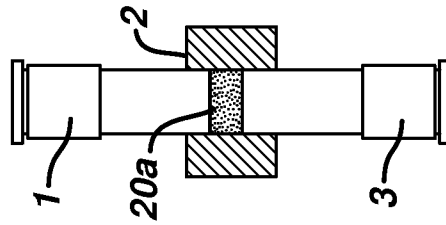

FIG. 3A

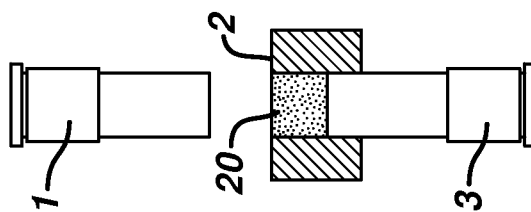

FIG. 3F

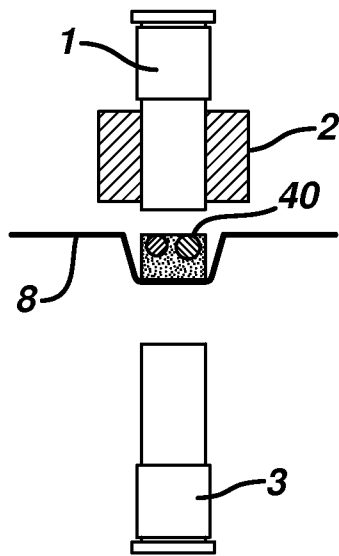

FIG. 3G

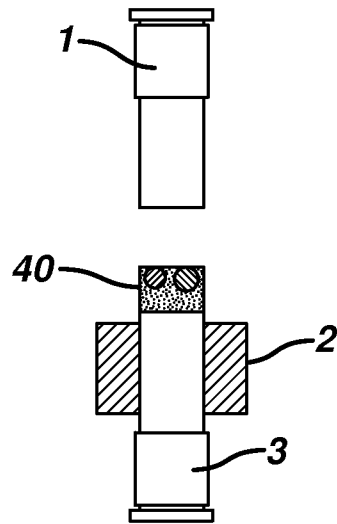

FIG. 4A

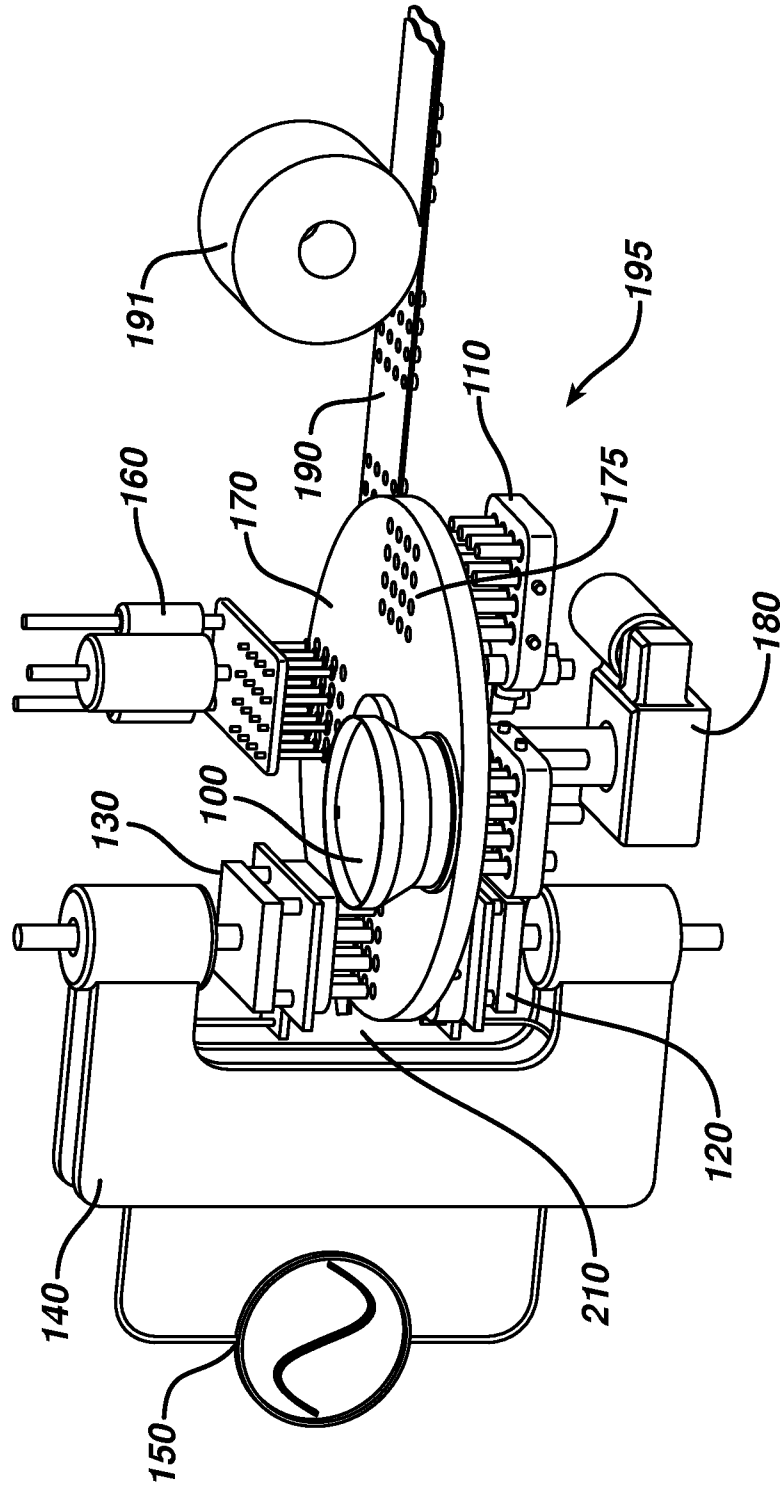

FIG. 4B

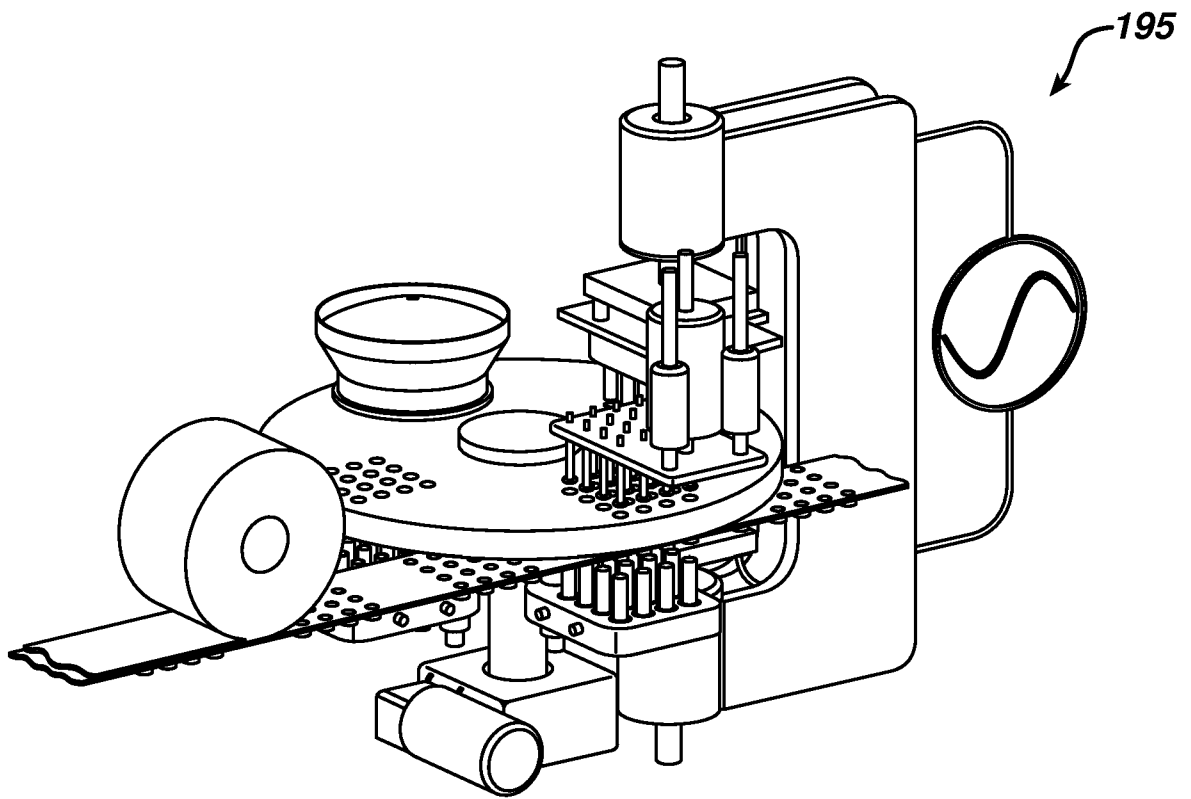

FIG. 5A

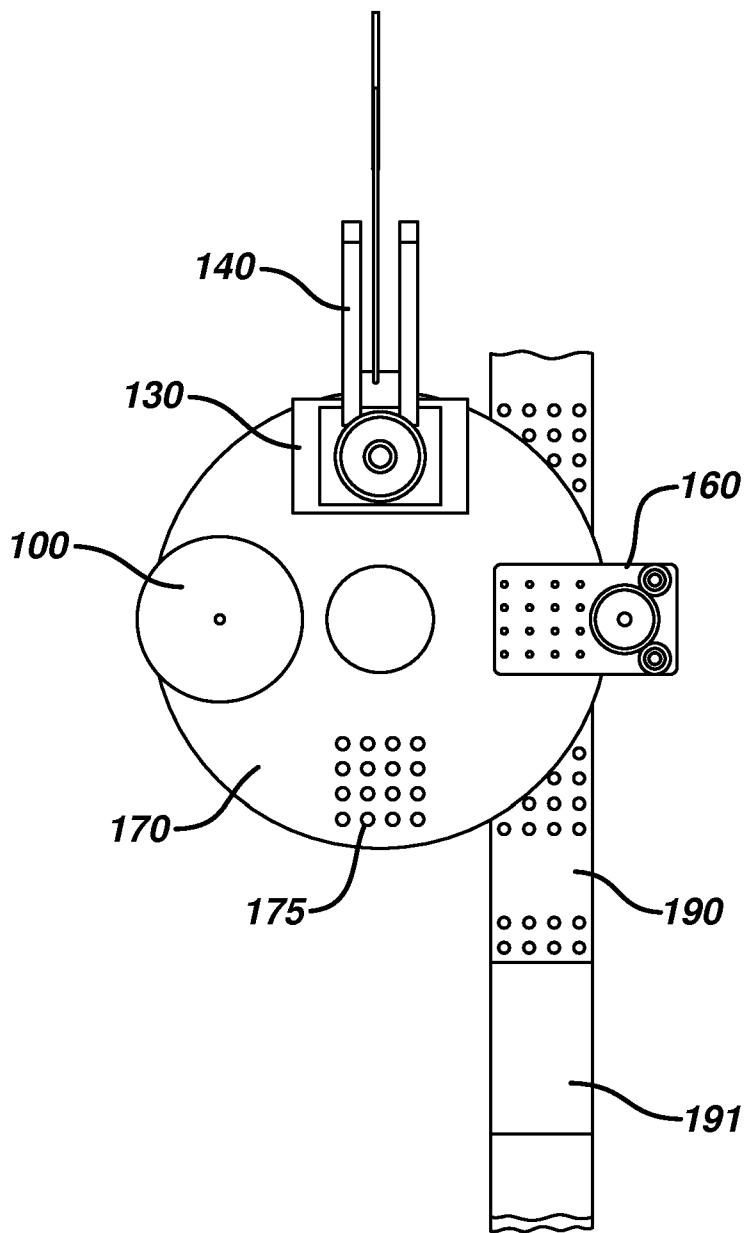
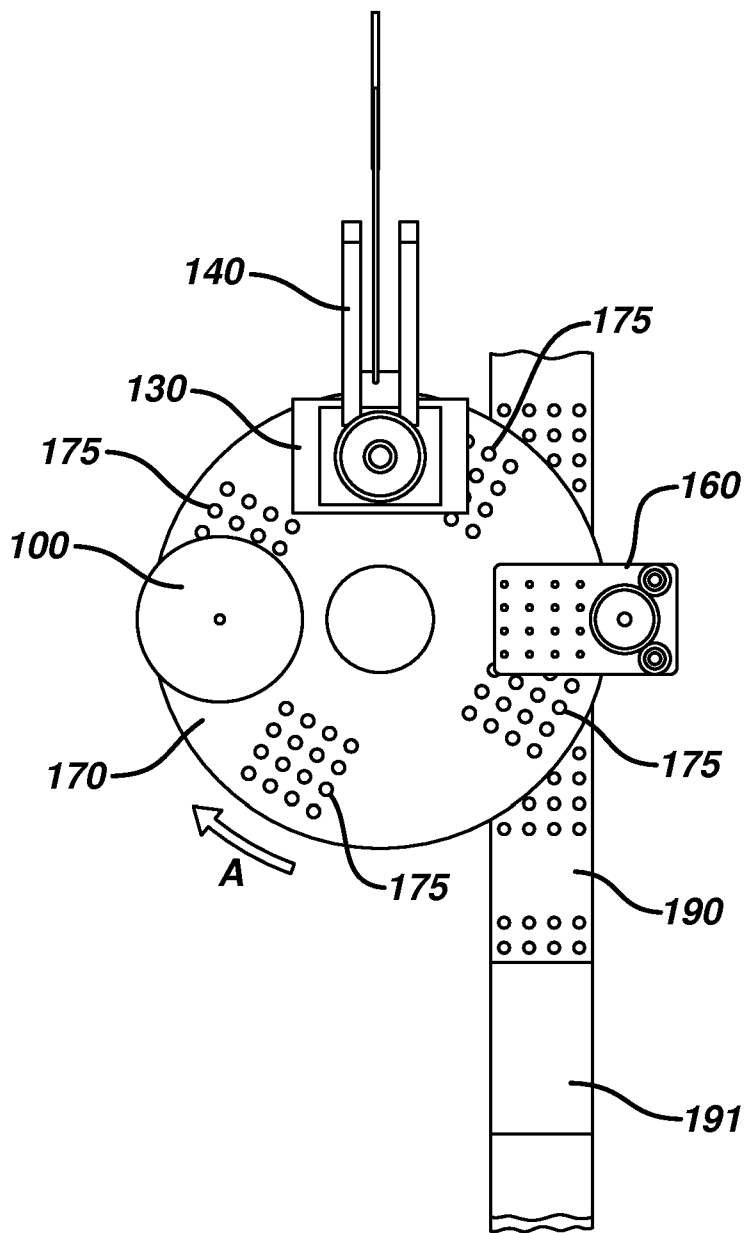

FIG. 5B



10/18

FIG. 6A

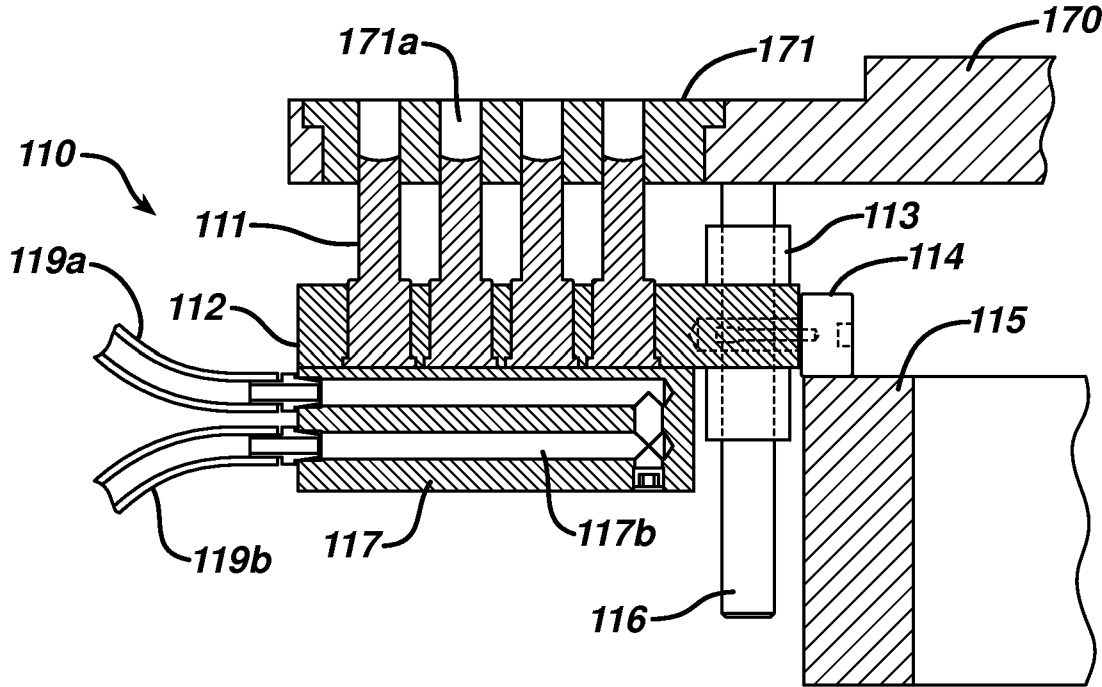

FIG. 6B

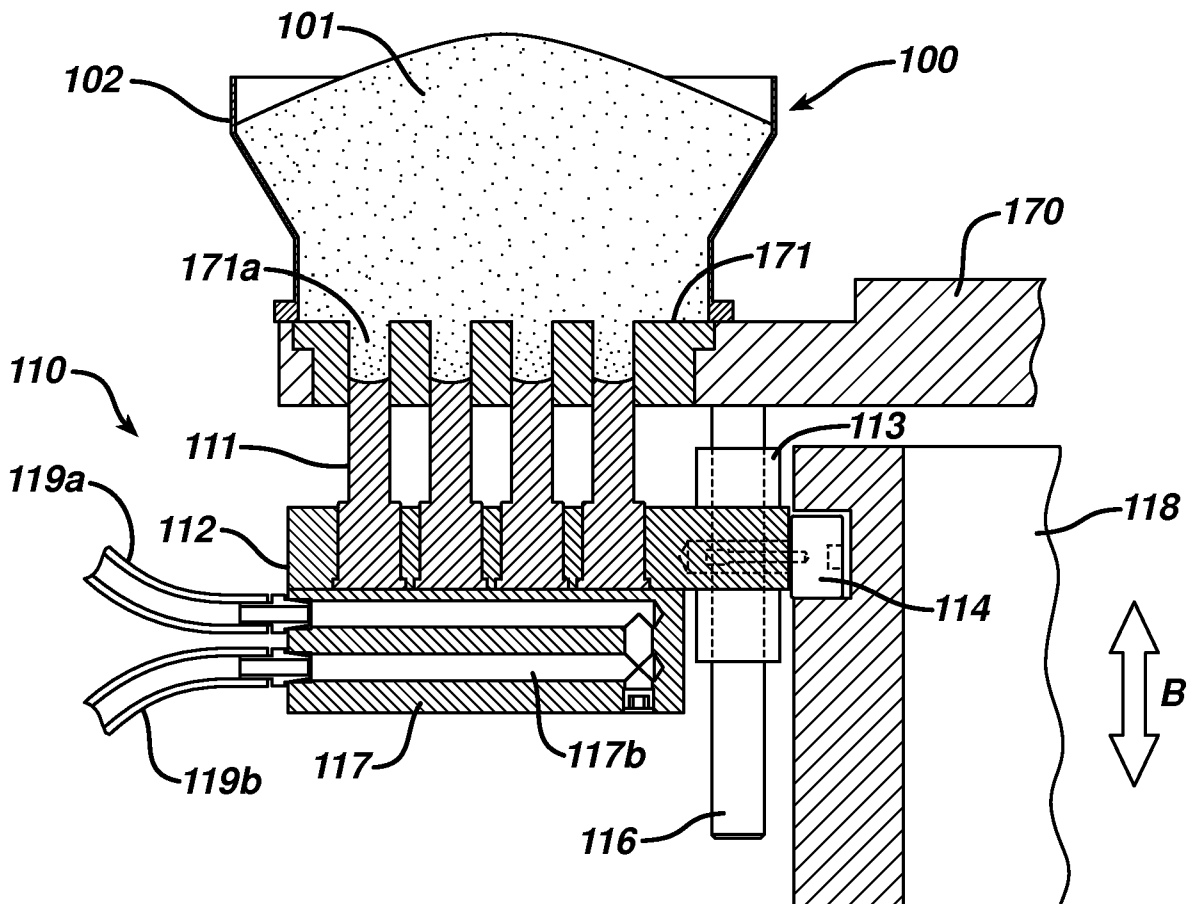

FIG. 7

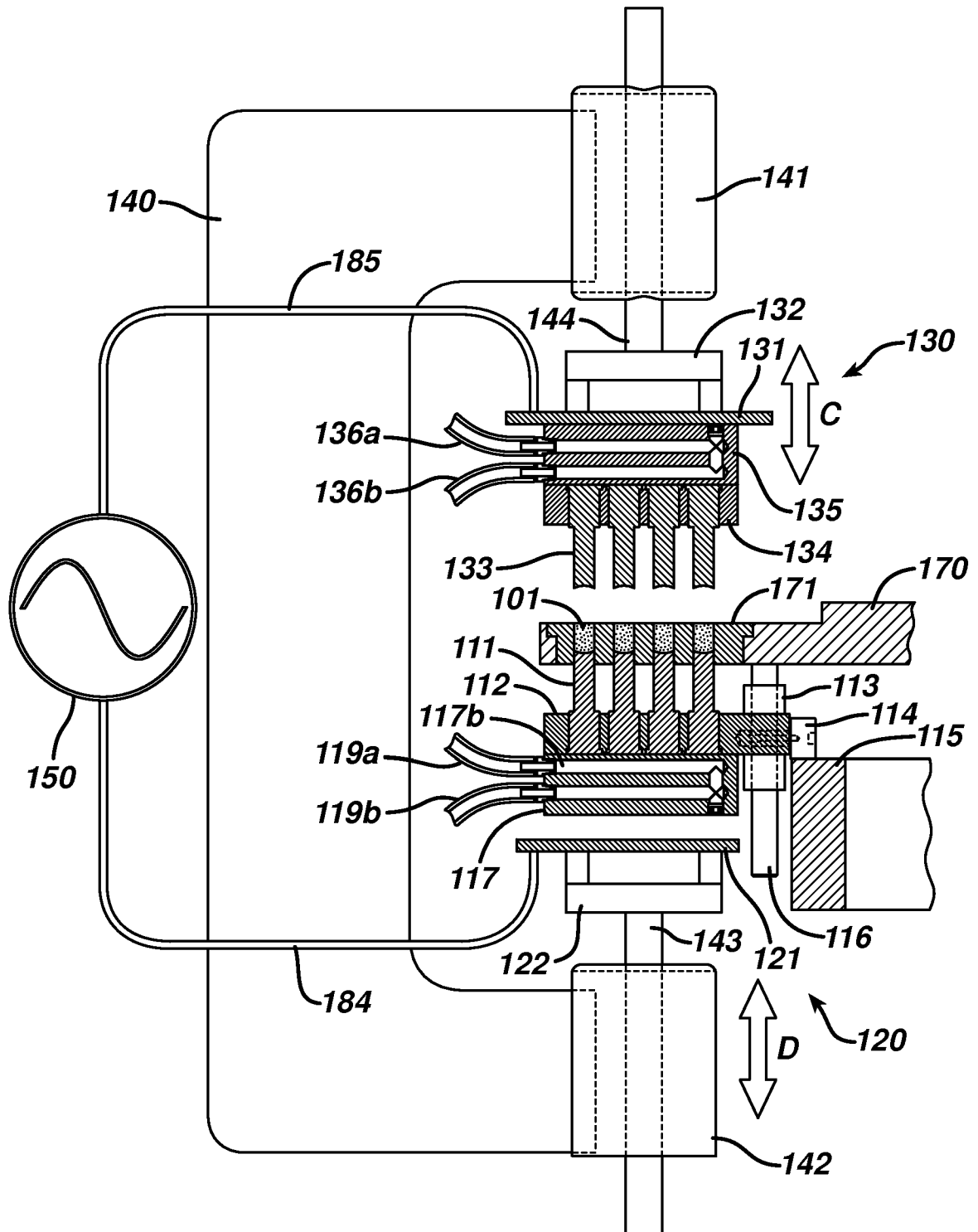

FIG. 8

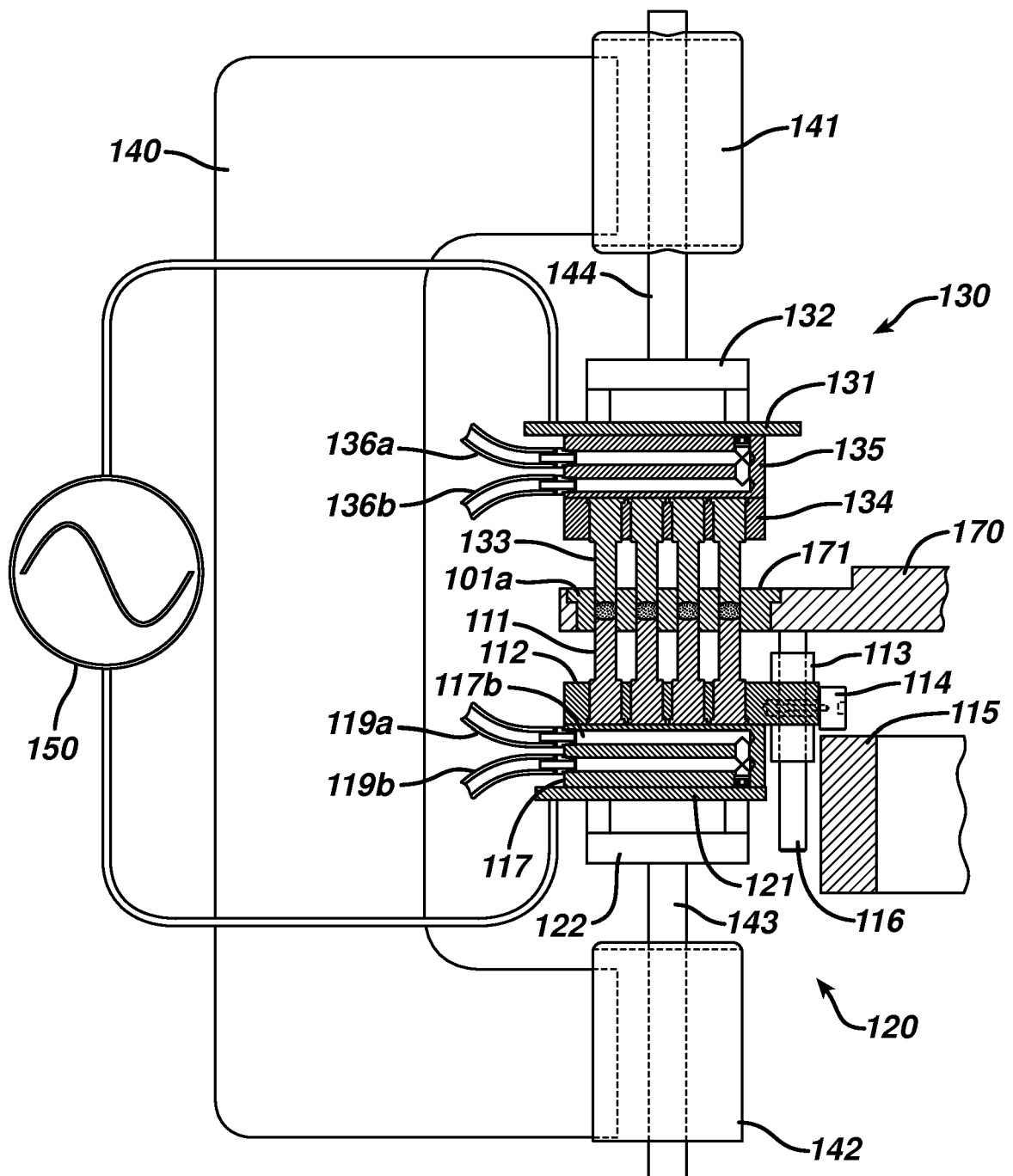

FIG. 9

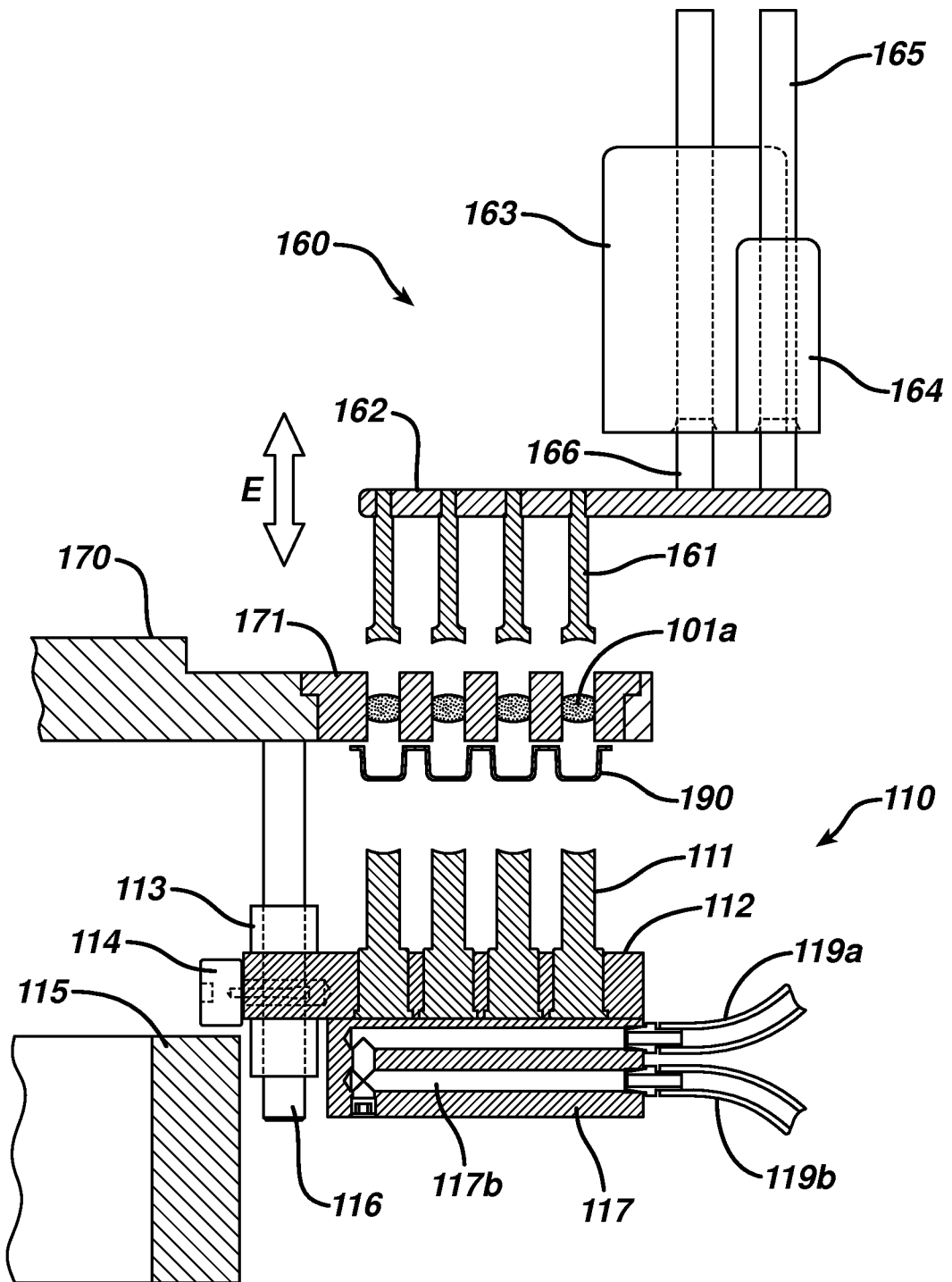

FIG. 10

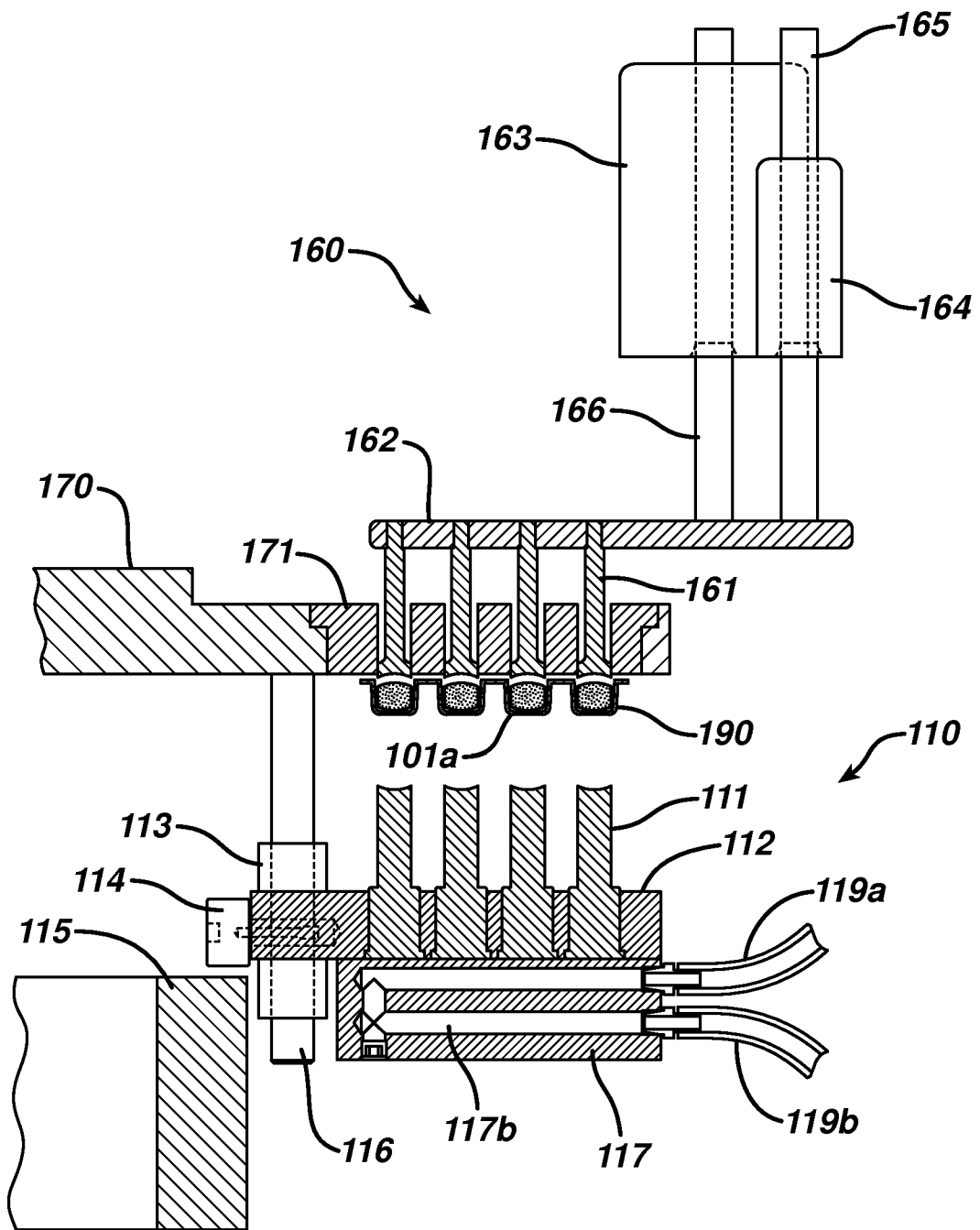

FIG. 11A

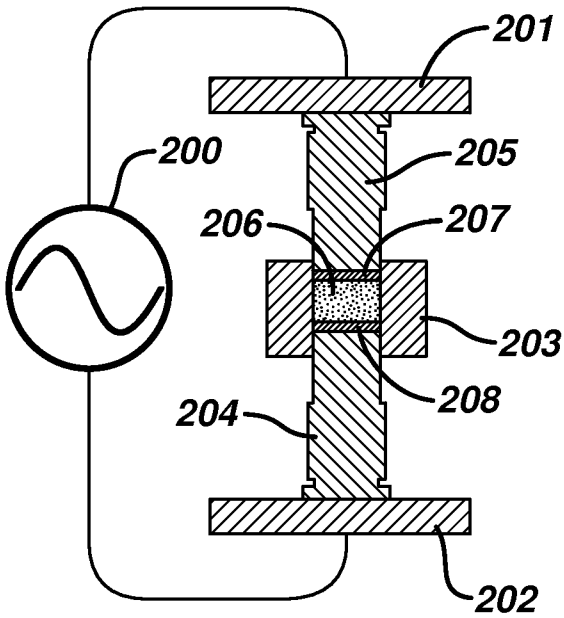

FIG. 11B

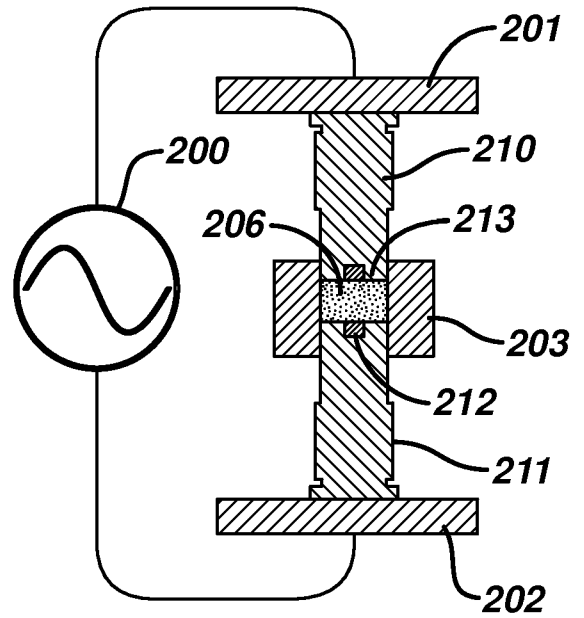

FIG. 11C

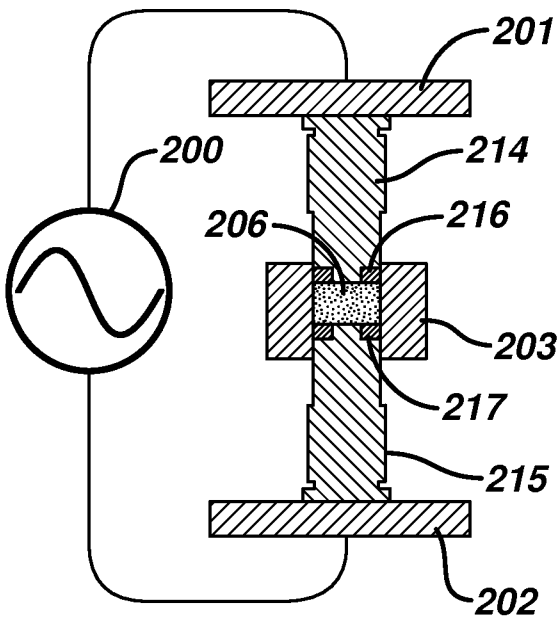

FIG. 11D

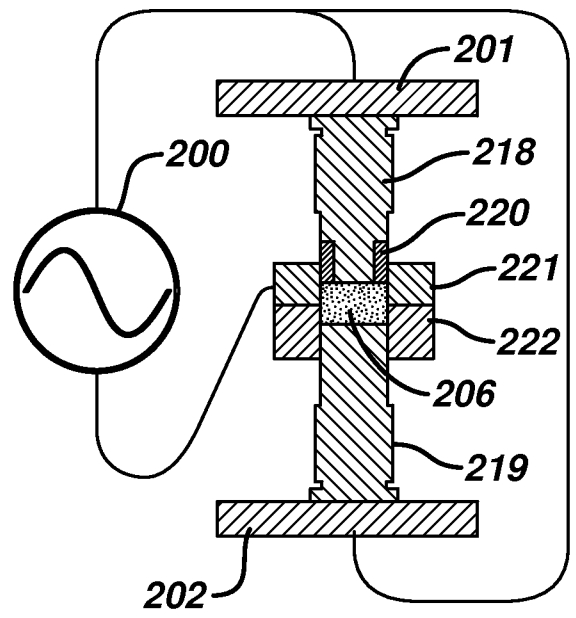

FIG. 12A

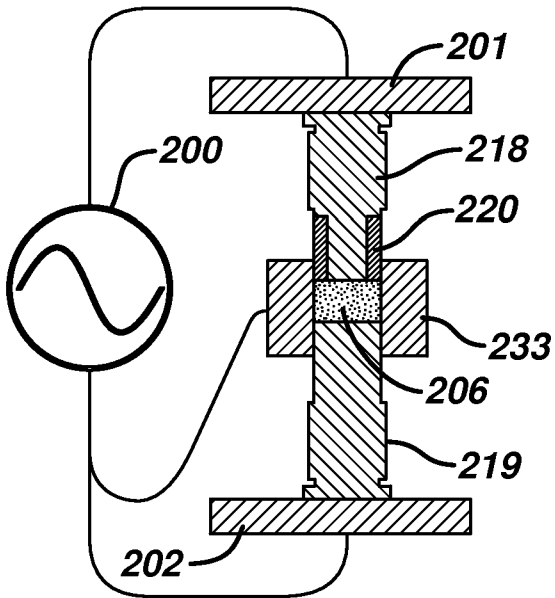

FIG. 12B

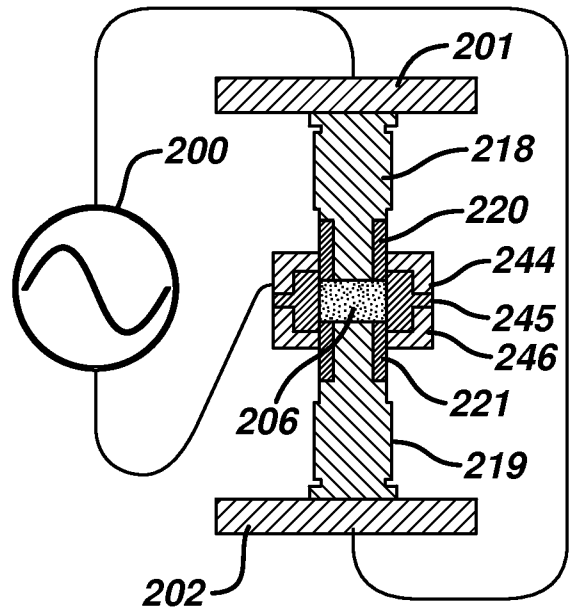

FIG. 12C

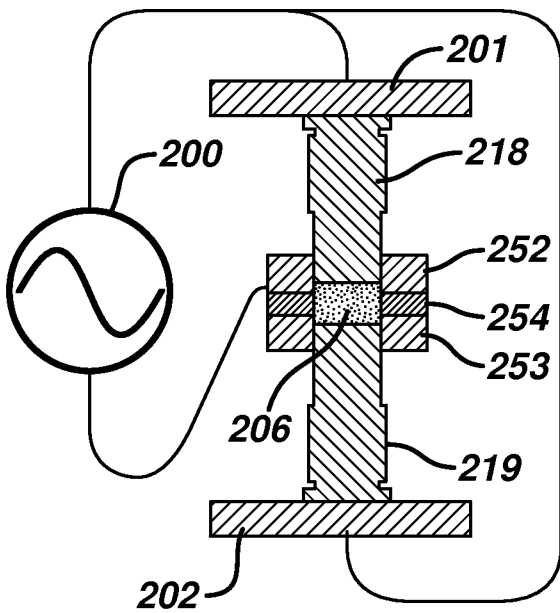

FIG. 12D

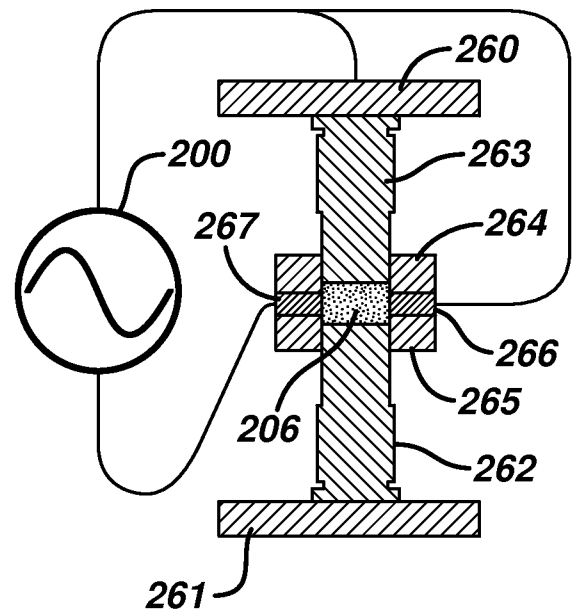

FIG. 13A

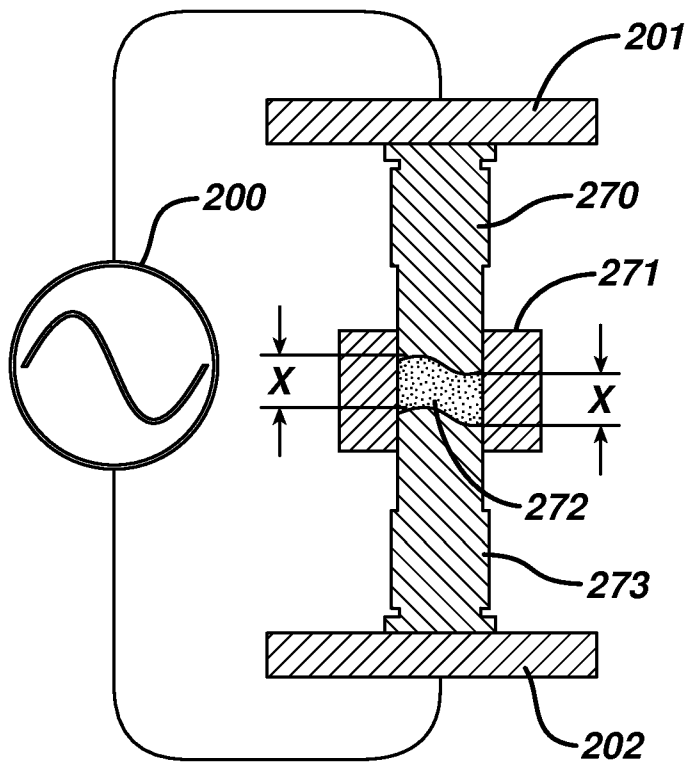

FIG. 13B

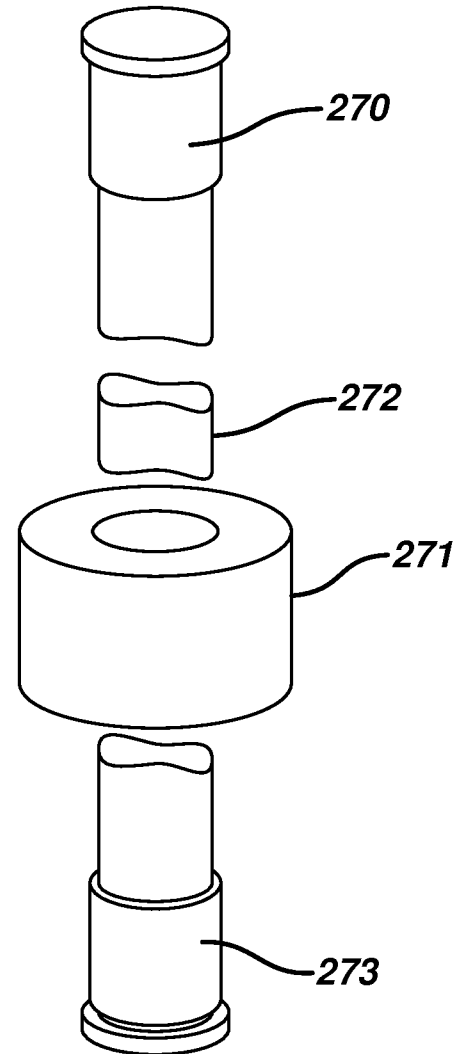
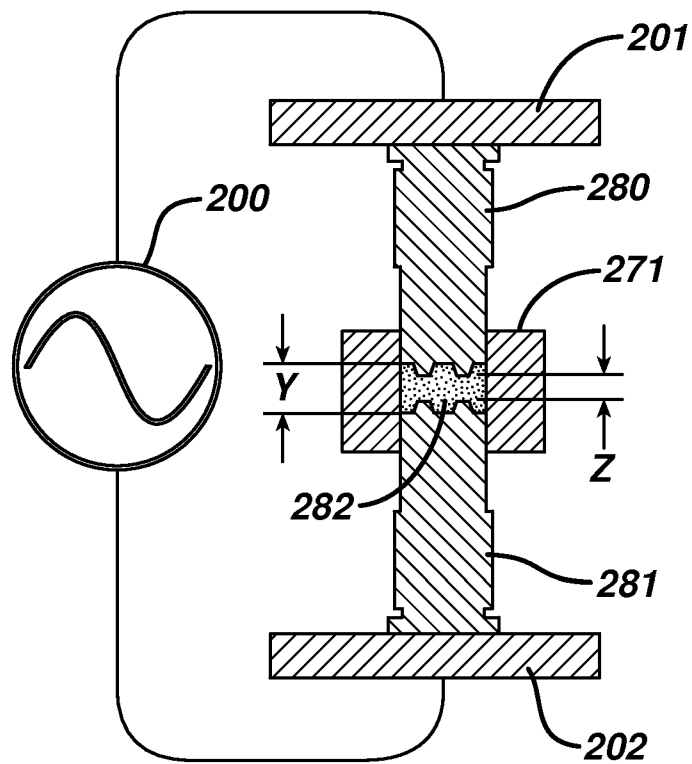

FIG. 14



INTERNATIONAL SEARCH REPORT

International application No

PCT/US2010/049971

A. CLASSIFICATION OF SUBJECT MATTER
 INV. A61K9/20 A61K9/00
 ADD.

According to International Patent Classification (IPC) or to both national classification and IPC

B. FIELDS SEARCHED

Minimum documentation searched (classification system followed by classification symbols)

A61K

Documentation searched other than minimum documentation to the extent that such documents are included in the fields searched

Electronic data base consulted during the international search (name of data base and, where practical, search terms used)

EPO-Internal, WPI Data

C. DOCUMENTS CONSIDERED TO BE RELEVANT

Category*	Citation of document, with indication, where appropriate, of the relevant passages	Relevant to claim No.
X	US 4 758 439 A (GODFREY JOHN C [US]) 19 July 1988 (1988-07-19) the whole document * abstract claims 1-13 examples 1-21	1-20
X,P	WO 2010/058218 A1 (INTRINSIQ MATERIALS GLOBAL LTD [IE]; CANHAM LEIGH TREVOR [GB]) 27 May 2010 (2010-05-27) the whole document claims 1-20; examples 1-3 ----- -/-- -----	19,20

 Further documents are listed in the continuation of Box C. See patent family annex.

* Special categories of cited documents :

A document defining the general state of the art which is not considered to be of particular relevance

E earlier document but published on or after the international filing date

L document which may throw doubts on priority claim(s) or which is cited to establish the publication date of another citation or other special reason (as specified)

O document referring to an oral disclosure, use, exhibition or other means

P document published prior to the international filing date but later than the priority date claimed

T later document published after the international filing date or priority date and not in conflict with the application but cited to understand the principle or theory underlying the invention

X document of particular relevance; the claimed invention cannot be considered novel or cannot be considered to involve an inventive step when the document is taken alone

Y document of particular relevance; the claimed invention cannot be considered to involve an inventive step when the document is combined with one or more other such documents, such combination being obvious to a person skilled in the art.

& document member of the same patent family

Date of the actual completion of the international search

21 December 2010

Date of mailing of the international search report

07/01/2011

Name and mailing address of the ISA/

European Patent Office, P.B. 5818 Patentlaan 2
 NL - 2280 HV Rijswijk
 Tel. (+31-70) 340-2040,
 Fax: (+31-70) 340-3016

Authorized officer

Felder, Christian

INTERNATIONAL SEARCH REPORT

International application No
PCT/US2010/049971

C(Continuation). DOCUMENTS CONSIDERED TO BE RELEVANT		
Category*	Citation of document, with indication, where appropriate, of the relevant passages	Relevant to claim No.
X	<p>WO 2008/005318 A2 (CAPRICORN PHARMA INC [US]; CHERUKURI SUBRAMAN RAO [US]) 10 January 2008 (2008-01-10) the whole document * abstract claims 1-32 examples 1-18</p> <p>-----</p>	19,20
A	<p>US 2009/060983 A1 (BUNICK FRANK J [US] ET AL) 5 March 2009 (2009-03-05) the whole document paragraph [0050] - paragraph [0065] claims 1-14; examples 1-4</p> <p>-----</p>	1-20
X	<p>WO 97/38679 A2 (NOVARTIS CONSUMER HEALTH SA [CH]; HUMBERT DROZ PIERRE [CH]; SEIDEL MAT) 23 October 1997 (1997-10-23)</p>	21
A	<p>the whole document claims 1-17</p> <p>-----</p>	1-20
A	<p>US 2006/134195 A1 (FU YOURONG [US] ET AL) 22 June 2006 (2006-06-22) the whole document * abstract claims 1-30 paragraph [0050] - paragraph [0060]</p> <p>-----</p>	1-20

INTERNATIONAL SEARCH REPORT

Information on patent family members

International application No

PCT/US2010/049971

Patent document cited in search report		Publication date	Patent family member(s)	Publication date
US 4758439	A	19-07-1988	NONE	
WO 2010058218	A1	27-05-2010	NONE	
WO 2008005318	A2	10-01-2008	US 2008008742 A1	10-01-2008
US 2009060983	A1	05-03-2009	AU 2008296532 A1 CA 2697886 A1 CN 101790372 A EP 2190416 A1 KR 20100069658 A US 2010021507 A1 WO 2009032655 A1	12-03-2009 12-03-2009 28-07-2010 02-06-2010 24-06-2010 28-01-2010 12-03-2009
WO 9738679	A2	23-10-1997	AT 260646 T AU 2636797 A DE 69727922 D1 DE 69727922 T2 DK 893992 T3 EP 0893992 A2 ES 2217410 T3 HK 1016492 A1 JP 2000508649 T PT 893992 E TR 9802068 T2 US 6083531 A ZA 9703190 A	15-03-2004 07-11-1997 08-04-2004 20-01-2005 01-06-2004 03-02-1999 01-11-2004 10-12-2004 11-07-2000 30-06-2004 21-01-2000 04-07-2000 17-12-1997
US 2006134195	A1	22-06-2006	NONE	