

(19)
(12)

(KR)
(Y1)

(51) 。 Int. Cl. 7
F16L 47/22

(45)
(11)
(24)

2003 01 29
20 - 0301957
2003 01 10

(21) 20 - 2002 - 0026436
(22) 2002 09 04

(73) 385 - 2

(72) 385 - 2

(74)

:

가 :

(54)

()

가

.

가

, ,

1

,

239705 (2001. 7. 12.)

가 가

	가	가		(2)	(1)
(2)	(3)	1	2	6	(2)
	(6)	.	(5)	,	(3)
					(4)
					(5)가
					(3)
3	7	(3)		(8)	(3)
(8)가		(9)		(8)	(4)
					(9)가
4	8	(2)			(3)
(10)		,	(3)		
(11)	(2)			(4)	(10)
					(6')
5	9	(2)			(3)
			(12)	,	(3)
	(6')		(11)		(4)
			(2)		(12)
(3)	(5)	(4)	1	2	(13)
			(6)		(2)가
					(13)
					6
	(2)가	(13)		(2)	30%
	(13)		10		
3			(13)	7	(3)
(9)		(2)가	(13)		(8)
					(4)
	(2)가	(13)		(2)	30%
	(13)		10		
4			(13)	8	(3)
	(6')		(2)가	(13)	(10)
1)					(4)
					(1)
	(2)가	(13)		(2)	30%
	(13)		10		
5			(13)	9	(3)
	(6')		(2)가	(13)	(12)
1)					(4)
					(1)

(2)가
(13)

(13)
10

(2)

30%

(2) (3, 4)

(13)

(1

3)

(57)

1.

가 가

(2)

(3)

(5)

(4)

(5)가

(6)

2.

3.

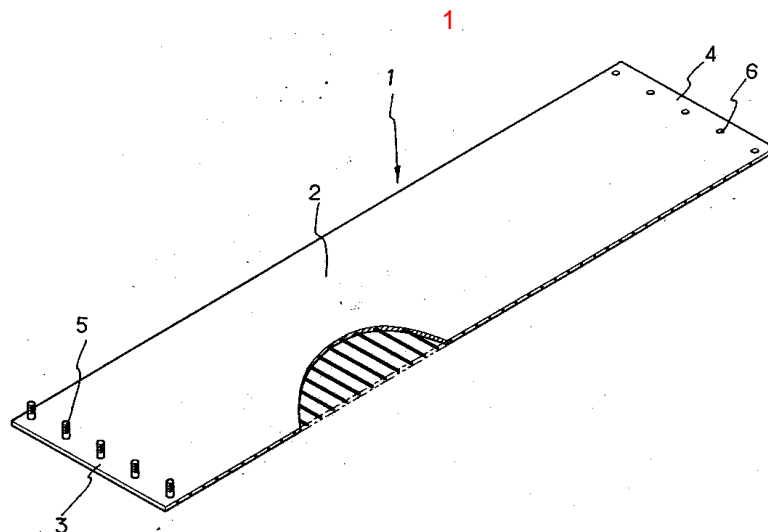

2

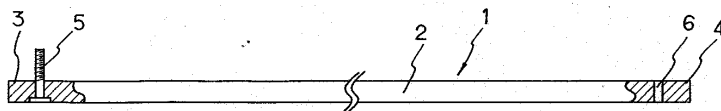

3

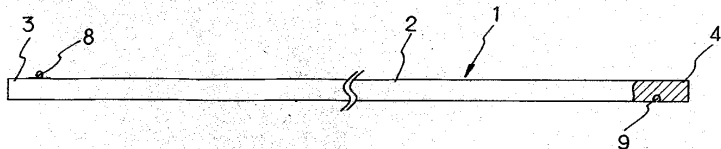

4

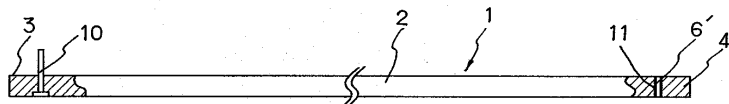

5

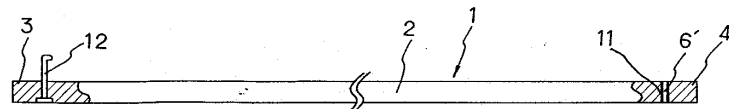

6

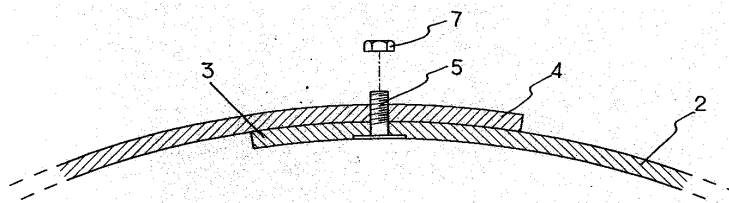

7

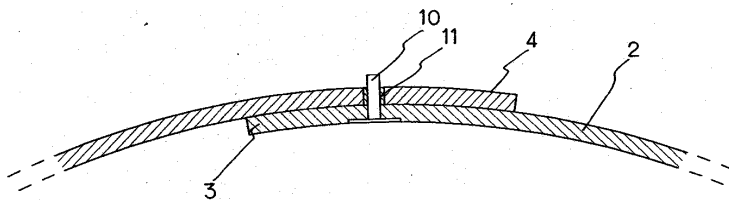

8

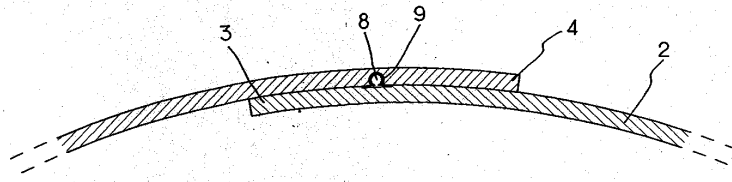

9

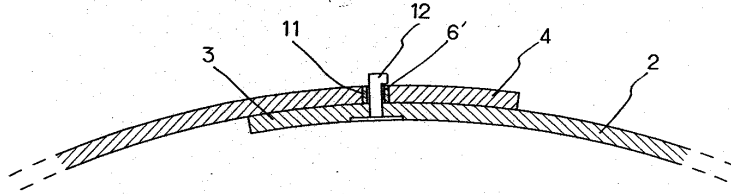

10

