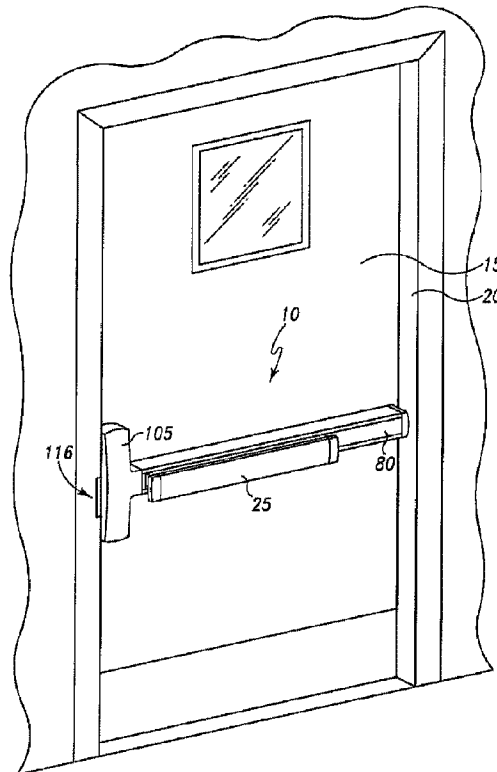




(22) Date de dépôt/Filing Date: 2014/12/30  
(41) Mise à la disp. pub./Open to Public Insp.: 2015/06/30  
(45) Date de délivrance/Issue Date: 2023/12/05  
(62) Demande originale/Original Application: 2 876 417  
(30) Priorité/Priority: 2013/12/30 (US61/921,838)

(51) Cl.Int./Int.Cl. *E05B 47/00* (2006.01),  
*E05B 47/06* (2006.01), *E05B 65/10* (2006.01)  
(72) Inventeurs/Inventors:  
ARLINGHAUS, PAUL RAYMOND, US;  
LEHNER, JACK R., JR., US  
(73) Propriétaire/Owner:  
SCHLAGE LOCK COMPANY LLC, US  
(74) Agent: NORTON ROSE FULBRIGHT CANADA  
LLP/S.E.N.C.R.L., S.R.L.

(54) Titre : DISPOSITIF DE SORTIE AVEC MECANISME DE SURCOURSE  
(54) Title: EXIT DEVICE WITH OVER-TRAVEL MECHANISM



(57) **Abrégé/Abstract:**

An over-travel mechanism configured to couple an input shaft and an output shaft in an exit device assembly. The input shaft is connected to an actuator that linearly displaces the input shaft, and the output shaft is connected to a locking member of the exit device. The over-travel mechanism includes a link coupled to the output shaft, and a preloaded elastic member transmits force between the input shaft and the link. Movement of the input shaft from a first input shaft position to a second input shaft position causes the elastic member to urge the link from a first link position toward a second link position. Movement of the input shaft from the second input shaft position to a third input shaft position causes the elastic member to elastically deform without moving the link from the second link position.

## ABSTRACT

An over-travel mechanism configured to couple an input shaft and an output shaft in an exit device assembly. The input shaft is connected to an actuator that linearly displaces the input shaft, and the output shaft is connected to a locking member of the exit device. The over-travel mechanism includes a link coupled to the output shaft, and a preloaded elastic member transmits force between the input shaft and the link. Movement of the input shaft from a first input shaft position to a second input shaft position causes the elastic member to urge the link from a first link position toward a second link position. Movement of the input shaft from the second input shaft position to a third input shaft position causes the elastic member to elastically deform without moving the link from the second link position.

## EXIT DEVICE WITH OVER-TRAVEL MECHANISM

### CROSS-REFERENCE TO RELATED APPLICATIONS

**[0001]** The present application claims the benefit of U.S. Provisional Patent Application No. 61/921,838 filed on December 30, 2013, and is a divisional patent application of CA 2,876,417 filed on December 30, 2014 the contents each of which are incorporated herein by reference in their entirety.

### TECHNICAL FIELD

**[0002]** The present invention generally relates to exit devices, and more particularly, but not exclusively, to pushbar-type exit devices with electrical actuators.

### BACKGROUND

**[0003]** Many present approaches to exit devices equipped with electrical retraction of a latch bolt or another type of locking member suffer from a variety of limitations. For example, certain conventional devices require calibrating or adjusting the position of the retracting mechanism to ensure that the locking member is fully retracted. If the positioning or calibration of the retracting mechanism is off even slightly, conventional systems are prone to experience detrimental effects. For example, when the retracting mechanism includes a solenoid, improper positioning will result in either the locking member not fully retracting, or the solenoid's plunger not reaching the end of its travel where it exhibits maximum hold force. When the retracting mechanism includes a motor, the motor may stall if it continues to operate after the locking member is fully retracted. Stalling of the motor may cause a spike in current draw, and tends to decrease the life of the motor. Both types of retracting mechanisms have a small tolerance for total travel to fully engage, retract or lock the locking device. Therefore, a need remains for further improvements in systems and methods for electromechanical actuation of exit devices.

## SUMMARY

[0004] An exemplary over-travel mechanism is configured to couple an input shaft and an output shaft in an exit device assembly. The input shaft is connected to an actuator operable to linearly move the input shaft, and the output shaft is connected to a locking member of the exit device. The over-travel mechanism includes a link coupled to the output shaft, and a preloaded elastic member transmits force between the input shaft and the link. Movement of the input shaft from a first input shaft position to a second input shaft position causes the elastic member to urge the link from a first link position toward a second link position. Movement of the input shaft from the second input shaft position to a third input shaft position causes the elastic member to elastically deform without moving the link from the second link position. Further embodiments, forms, features, aspects, benefits, and advantages of the present invention shall become apparent from the description and figures provided herewith.

## BRIEF DESCRIPTION OF THE FIGURES

- [0005] FIG. 1A illustrates an exit device according to one embodiment, as mounted on a door.
- [0006] FIG. 1B illustrates the exit device of FIG. 1A with a latch bolt positioned in a first outer position.
- [0007] FIG. 1C illustrates the exit device of FIGS. 1A and 1B with the latch bolt positioned in a second inner position.
- [0008] FIG. 2 illustrates a control system according to one embodiment for use in association with the exit device.
- [0009] FIG. 3 illustrates the control system connected to a locking mechanism of the exit device.
- [0010] FIG. 4 illustrates a portion of the locking mechanism operably connected to a pushbar of the exit device.
- [0011] FIG. 5 illustrates an over-travel assembly and control system according to one embodiment.
- [0012] FIG. 6 illustrates a link used in association with the over-travel assembly of FIG. 5.
- [0013] FIG. 7 illustrates a housing used in association with the over-travel assembly of FIG. 5.
- [0014] FIGS. 8-10 illustrate various operational stages of an over-travel assembly according to one embodiment.
- [0015] FIGS. 11 and 12 illustrate another embodiment of the over-travel assembly illustrated in FIG. 5.

## DETAILED DESCRIPTION OF ILLUSTRATIVE EMBODIMENTS

[0016] For the purposes of promoting an understanding of the principles of the invention, reference will now be made to the embodiments illustrated in the drawings and specific language will be used to describe the same. It will nevertheless be understood that no limitation on the scope of the invention is hereby intended. Any alterations and further modifications in the described embodiments, and any further applications of the principles of the invention as described herein are contemplated as would normally occur to one skilled in the art to which the invention relates.

[0017] FIGS. 1A-1C illustrate an exit device 10 according to one embodiment. As illustrated in FIG. 1A, the exit device 10 is mounted on the inside of a door 15 for locking and unlocking the door 15. In some embodiments, the door 15 may generally be utilized as an emergency or fire exit of a building. More particularly, the exit device 10 remains locked (in FIGS. 1A and 1B characterized by a pushbar 25 being positioned in an outer state), thereby preventing a person from accessing or opening the door 15 from the outside of the building. To unlock the door 15 from the inside of the building, a user pushes or actuates the pushbar 25 (as shown in FIG. 1C), which in turn actuates a locking mechanism (further described below) to unlock the door 15. In the illustrated construction, a latch bolt 30 (FIG. 1B) operably connected to the locking mechanism extends from the exit device 10 to lock and unlock the door 15. With particular reference to FIG. 1A, the door 15 is locked when the latch bolt 30 extends from the exit device 10 and is received within a receiving aperture or against a strike on a door frame 20. The door 15 is unlocked by a user pressing the pushbar 25 (FIG. 1C), which in turn actuates the locking mechanism to retract the latch bolt 30. This type of exit device is known in the art and need not be described in further detail. It is to be understood that other constructions of the exit device 10 fall within the scope of the invention.

[0018] With reference to FIGS. 1-4, the exit device 10 includes a housing 35 with a midrail portion 40 and a head portion 45. The midrail portion 40 includes a base plate 50 for coupling the exit device 10 to a door 15, and two side walls 55 each extending outwardly from the plate 50 and including a ledge 60. The plate 50 and the side walls 55 of the midrail portion 40 define an inner space 65 for enclosing a control system 70 and a locking mechanism 75. The pushbar 25 is coupled to the locking mechanism 75 and is at least partially received within the inner space 65. In the illustrated embodiment, the pushbar 25 extends from the left end to a middle section of the

midrail portion 40 (with respect to FIG. 2), and cooperates with the midrail portion 40 to substantially enclose the locking mechanism 75. The pushbar 25 includes a head portion 136 with two inwardly extending walls 137 (only one shown in FIG. 4) and end caps 138 at the ends of the pushbar 25, with each end cap 138 defining a channel.

**[0019]** The control system 70 is located within the inner space 65 toward the right end of the midrail portion 40. A sliding plate 80 is received on the right end of the midrail portion 40 for enclosing the control system 70 in cooperation with the midrail portion 40. Accordingly, a user may access the control system 70 by at least partially sliding the plate 80 from engagement with the midrail portion 40. An end cover 100 is located at the right end of the midrail portion 40. The end cover 100 cooperates with the sliding plate 80 to enclose the control system 70 and the locking mechanism 75 within the inner space 65.

**[0020]** With reference to FIGS. 2 and 3, the head portion 45 of the exit device 10 includes a cover 105 for enclosing a head mechanism 106 connected to the locking mechanism 75, and being operable to actuate the latch bolt 30. The head mechanism 106 includes a housing 108, a locking link 110, the latch bolt 30, and an auxiliary bolt 112. The link 110 is also coupled to a shaft 160 of the locking mechanism 75 via a split link 114. The split link 114 is connected to the link 110 such that the link 110 and the split link 114 are displaced together. The split link 114 is connected to the shaft 160 by a lost-motion connection. A spring 118 extends between the split link 114 and the end of the shaft 160 to bias the split link 114 to the left relative to the shaft 160. Movement of the split link 114 to the right compresses the spring 118, but does not move the shaft 160. However, movement of the shaft 160 to the right pulls the split link 114 to the right.

**[0021]** The head mechanism 106 typically includes a latch bolt link positioned within the housing 108 to couple the latch bolt 30 to the link 110. In the illustrated embodiment, the latch bolt 30 and the auxiliary bolt 112 extend from one end of the housing 108 opposite the link 110 to engage a strike 116 (partially illustrated in FIG. 1A). The latch bolt 30 is pivotally coupled to the housing 108 such that, when the link 110 pulls the latch bolt link, the latch bolt 30 pivots from an extended position (as shown in FIGS. 1B, 2 and 3) to a retracted position (as shown in FIG. 1C).

**[0022]** The auxiliary bolt 112 is coupled to the latch bolt 30 for movement with the latch bolt 30 between the extended position and the retracted position. The auxiliary bolt 112 is also movable (e.g., retractable) relative to the latch bolt 30. The spring 118 and the lost-motion connection

between the split link 114 and the shaft 160 prevent independent inward movement of the latch bolt 30, such as when the door 15 is closed and the latch bolt 30 passes the strike 116, to transfer motion from the head mechanism 106 to the locking mechanism 75. More specifically, when the exit device 10 is in its locked position (characterized by the pushbar 25 and the latch bolt 30 being positioned in their outer states), movement of the latch bolt 30 from its extended position (FIG. 1B) to its retracted position (FIG. 1C) compresses the spring 118 as the split link 114 moves to the right relative to the shaft 160. However, the motion of the split link 114 is not transferred to the shaft 160. Once the latch bolt 30 is free to return to its extended position, such as after it has passed the strike 116 during closing of the door 15, the spring 118 exerts sufficient force on the split link 114 to move the split link 114 to the left relative to the shaft 160 and to cause the latch bolt 30 to return to its extended or outer position.

**[0023]** In one example, when the door 15 is closed (FIG. 1A), the latch bolt 30 is in the extended position to engage the strike 116. The auxiliary bolt 112 contacts the strike 116 such that the strike 116 pushes the auxiliary bolt 112 toward the retracted position. When the latch bolt 30 is extended and the auxiliary bolt 112 is retracted, the auxiliary bolt 112 actuates or allows actuation of a deadlock mechanism to a position in engagement with the latch bolt 30 and/or the link 110. In this position, the deadlock mechanism inhibits retraction of the latch bolt 30, thereby preventing the door 15 from being forced or pushed open. When a user wishes to open the door 15, the user actuates the pushbar 25 to move the shaft 160, and thereby the link 110, to the right. As the link 110 moves to the right, the link 110 disengages the deadlock mechanism. The link 110 also pulls the latch bolt link so as to pivot the latch bolt 30 to the retracted position, thereby allowing the door 15 to be opened.

**[0024]** With reference to FIGS. 3 and 4, a base plate 115 supports the locking mechanism 75 and the control system 70. The plate 115 can be coupled to the plate 50 of the midrail portion 40 by any conventional means to provide support to the locking mechanism 75 and the control system 70. The locking mechanism 75 includes two base brackets 120 fixedly coupled to the plate 115 and longitudinally spaced apart from one another in the longitudinal direction of the plate 115. Each bracket 120 includes a base portion with extensions 121 for receiving screws 125. Each bracket 120 also includes outwardly extending wall portions 122 substantially parallel to one another and spaced along the width of the plate 115.

**[0025]** Each bracket 120 supports a bell crank mechanism 127 (partially illustrated in FIG. 3) including a bell crank link 130 coupled to a pushbar support bracket 135 and the shaft 160. Details regarding the bell crank mechanism 127 are known by those of ordinary skill in the art and therefore will not be described in detail herein. The bell crank mechanism 127 transfers motion between the pushbar 25 and the shaft 160 upon actuation of one or the other. The pushbar 25 is mounted on the support brackets 135 and at least partially encloses the locking mechanism 75. A pin 145 couples each support bracket 135 to the associated bell crank link 130 and allows pivotal movement between the support bracket 135 and the bell crank link 130. Accordingly, inward movement (downward in FIG. 4) of the pushbar 25, and therefore of the support brackets 135, allows the bell crank mechanism 127 to move the shaft 160 to its unlocked position.

**[0026]** A spring 195 is mounted on the shaft 160 between a bracket 170 and a stop adjacent the right bracket 120. In the illustrated construction, the bracket 170 is slideably mounted on the shaft 160, and motion of the bracket 170 to the left along the shaft 160 is limited by a pin 152 extending through the shaft 160. The spring 195 exerts a force on the bracket 170, and thereby on the shaft 160, to bias the shaft 160 toward its locked position (i.e., to the left). A damping mechanism 150 extends between the left bracket 120 and the bracket 170. As indicated above, inward movement of the pushbar 25 causes movement of the shaft 160 toward the unlocked position (i.e., to the right). During movement of the shaft 160 to the right, the pin 152 moves with the shaft 160 and acts against the bracket 170 to thereby cause the bracket 170 to move to the right with the shaft 160, which in turn causes the spring 195 to compress. When the pushbar 25 is released, the force of the spring 195 on the bracket 170 moves the shaft 160 to the left (i.e., the locked position). During movement of the shaft 160 to the left, the damping mechanism 150 acts against the bracket 170 and limits the speed with which the shaft 160 moves to the left. This in turn limits the speed of outward movement of the pushbar 25. The damping mechanism 150 does not limit the speed with which the shaft 160 moves to the right (i.e., the unlocked position). Thus, the pushbar 25 can be pushed in and the door 15 can be unlocked as quickly as possible.

**[0027]** With reference to FIGS. 4 and 5, a beam 196 is coupled to the right end of the shaft 160 and includes an elongated aperture or slot 198 extending from a middle section to the right end of the beam 196. The beam 196 may include an aperture aligned with an aperture in the shaft 160 for receiving a pin, thereby coupling the shaft 160 and the beam 196 to the right of the bell

crank link 130 (FIG. 3). The beam 196 is also coupled to an over-travel assembly 199 configured to move the beam 196 upon actuation of the control system 70. The over-travel assembly 199 includes a drive link 200 and an elastic member (depicted as a spring 202), and may further include a housing 300. The drive link 200 is coupled to the beam 196 with a lost-motion connection, thereby allowing the beam 196 to move in the longitudinal direction with respect to the link 200. The link 200 is positioned within the housing 300 and is movable in the longitudinal direction with respect to the housing 300.

**[0028]** The control system 70 includes a motor 410 having an axially movable output shaft 412, and a control module 420 configured to control operation of the motor 410. The motor 410 is preferably a stepper motor such that axial movement of the shaft 412 can be measured or defined in a number of steps of the motor 410. However, other constructions of the control system 70 may include another form of motor. The output shaft 412 has external threads that threadedly engage internal threads on the rotor of the motor 410 such that rotation of the rotor causes axial movement of the shaft 412 along the longitudinal axis X. When the motor 410 rotates the nut in one direction, the motor shaft 412 is pulled inward (i.e., toward the control module 420). When the motor 410 rotates the nut in the opposite direction, the motor shaft 412 is pushed outward (i.e., toward the beam 196). The motor shaft 412 may include a splined section in engagement with a corresponding splined section in the motor 410, thereby preventing the motor shaft 412 from rotating relative to the motor 410 as the nut rotates.

**[0029]** In the illustrated embodiment, the motor 410 is a stepping motor, and the control module 420 sends a series of electrical pulses or steps to the motor 410 to control the linear motion of the motor shaft 412. The number of pulses sent by the control module 420 controls the distance that the motor shaft 412 is displaced. In other embodiments, the linear motion may be provided in another manner. For example, in certain embodiments, the control system 70 may include a rack and pinion linear actuator, a geared design using chains or belts, a linear motor actuator, or other types of motion control systems. Such alternatives may also be designed with or without stepping motors.

**[0030]** With reference to FIG. 6, the link 200 includes a channel 201 defined by coupling arms 210, side walls 220, and arms 230, all of which are substantially parallel to one another. The channel 201 is further defined by a bottom wall 221 connecting the side walls 220, and an end wall 240 extending from one of the arms 230 toward the other of the arms 230. The beam 196 is

positioned at least partially within the channel 201, and the slot 198 is positioned between the coupling arms 210 and is aligned with openings 212 formed in the coupling arms 210. A pin 481 extends through the openings 212 and the slot 198, and is prevented from moving in the transverse direction (i.e., in a direction perpendicular to the longitudinal axis X). In the illustrated form, a circlip 491 substantially prevents movement of the pin 481 in one of the transverse directions, and movement of the pin 481 in the other transverse direction is also substantially prevented, for example by a second circlip or a portion of the pin 481 having a diameter greater than that of the opening 212.

**[0031]** Each of the side walls 220 includes an opening 222 configured to receive a guide pin 482. One or both of the side walls 220 may also include a screw hole 223. The arms 230 extend from the side walls 220 in the longitudinal direction, and each includes a longitudinal slot 232 configured to slidably receive a pin 483. The end wall 240 is formed on one of the arms 230 and includes an opening 242. When the over-travel assembly 199 and the control system 70 are assembled, the shaft 412 extends through, but is not threaded into, the opening 242. As further explained below, the over-travel assembly 199 is actuated by the motor shaft 412 to move the link 200 between extended and retracted positions.

**[0032]** With additional reference to FIG. 7, the housing 300 includes base flanges 310, a pair of substantially parallel side walls 320, and may further include L-shaped mounting arms 340 extending from the side walls 320. The base flanges 310 include openings 312 configured to receive fasteners for coupling the housing 300 to the plate 115, thereby providing the housing 300 with a fixed position with respect to the door 15.

**[0033]** The side walls 320 are formed on opposite sides of the link 200 to help guide the link 200 in a longitudinal direction, and also include guide slots 322 aligned with the link openings 222. The guide pin 482 extends through the openings 222 and the guide slots 322, and is held in place by a circlip 492. The guide slots 322, the pin 482, and the circlip 492 restrict movement of the link 200 to the longitudinal direction, thereby substantially preventing the link 200 from pivoting during extension or retraction of the link 200 with respect to the housing 300.

**[0034]** The side walls 320 are connected by a top wall 321, and include slots 332 configured to slidably receive the pin 483. During assembly, the motor shaft 412 is passed through the opening 242 and the spring 202, and the spring 202 is preloaded with a preloading deformation. In the illustrated embodiment, the spring 202 is a compression-type coil spring, and the

preloading deformation is a preloading compression of the spring 202. It is also contemplated the spring 202 may be replaced by a tension spring which interconnects the pins 482, 483. In such an embodiment, the preloading deformation is a preloading tension in the tension spring. In further embodiments, the spring 202 may be replaced by another type of elastic member such as, for example, a torsion spring.

**[0035]** Once the spring 202 is preloaded, the pin 483 is passed through the slots 232, 332 and an opening formed in the motor shaft 412, and is held in place by a circlip 493. In this manner, the spring 202 is retained between the pin 486 and the end wall 240 in a compressed state, thereby providing a pre-loading force that resists relative motion of the link 200 and the motor shaft 412. The housing slots 332 extend a greater distance in the longitudinal direction than the link slots 232. Accordingly, the guide pin 483 (and therefore the motor shaft 412) has a greater range of motion with respect to the housing 300 than with respect to the link 200. The mounting arms 340 are positioned adjacent the motor 410, and may include openings 342 configured to receive fasteners for coupling the housing 300 to the motor 410.

**[0036]** With additional reference to FIG. 8, the exemplary control module 420 includes a housing 421 having an opening 422 configured to receive the motor shaft 412. The control module 420 also includes a printed circuit board (PCB) 423 operably connected to the motor 410 and supporting a microcontroller 424, and may further include a sensor 425 in communication with the microcontroller 424. In the illustrated embodiment, the sensor 425 is configured to send a stop signal to the microcontroller 424 when the motor shaft 412 is fully retracted and the motor shaft 412 is in close proximity to the sensor 425 (FIG. 10). In other forms, the sensor 425 may be configured to sense positions of the motor shaft 412 other than the fully retracted position. An exemplary form of a control module 420 utilizing such a sensor arrangement is described below. The microcontroller 424 may also be capable of generating a status signal indicative of the status of the motor 410 and/or the locking mechanism 75.

**[0037]** In the illustrated embodiment, operation of the exit device 10 includes manually unlocking the exit device 10, and may further include manually or automatically dogging the exit device 10. Manually unlocking the exit device 10 includes operating the locking mechanism 75 by manually actuating the pushbar 25 from its outer state (FIGS. 1A, 1B) to its inner state (FIG. 1C). Although not shown, the exit device 10 may include a mechanically operated dogging device wherein a user is able to "lock" the locking mechanism 75 in its unlocked position or

inner state of the pushbar 25. Automatically dogging the exit device 10 includes operating the motor 410 to retract the motor shaft 412 to the right along the longitudinal axis X to an over-travel position, and retaining the motor shaft 412 in the over-travel position, the details of which are described in further detail below.

**[0038]** During manual operation of the exit device 10, the door 15 is unlocked by inwardly pushing the pushbar 25. Inward movement of the pushbar 25 translates into movement of the shaft 160 (to the right) via the bell crank mechanism 127. As a result, the split link 114 pulls the link 110 which in turn actuates the latch bolt 30 for unlocking the door 15. Also, moving the shaft 160 to the right compresses the spring 195, thereby generating a force biasing the shaft 160 to the left. The biasing force causes the shaft 160, pushbar 25 and latch bolt 30 to move to their locked or outer positions once the user releases the pushbar 25.

**[0039]** Moving the shaft 160 to the right also causes the beam 196 to move in the same direction. The beam 196 can move between the locked position and the unlocked position without affecting the link 200 because of the lost-motion connection between the beam 196 and the link 200. More specifically, restricted movement of the pushbar 25 and/or operation of locking mechanism 75 allows travel of the beam 196 with respect to the link 200 such that the beam 196 does not reach or engage the motor shaft 412. In the illustrated embodiment, inward travel of the pushbar 25 is limited by engagement of the pushbar 25 (e.g., extending walls 137 and/or end caps 138) with the plate 115 and/or one or more stops within the exit device 10. Further, one or more stops within the exit device 10 can also restrict actuation of the locking mechanism 75 by restricting movement of one or more elements thereof in at least one direction (e.g., shaft 160 or latch bolt 30).

**[0040]** Automatic operation of the exit device 10 is described with reference to FIGS. 2, 3, and 8-10. Particularly, FIGS. 8-10 are schematic representations of the over-travel assembly 199 as the motor shaft 412 progresses from a locking position (FIG. 8) to an unlocking position (FIG. 9) and to an over-travel position (FIG. 10). In the interest of clarity, certain elements and features not relevant to the following description (such as the slot 198 and the housing 300) are omitted from FIGS. 8-10.

**[0041]** FIG. 8 depicts the motor shaft 412 in the locking position. With the motor shaft 412 in the locking position, wherein the link 200 is in an extended position, and the pushbar 25 and the latch bolt 30 are positioned in their outer states. The microcontroller 424 begins operation of the

exit device 10 in response to a start condition, such as a power supply providing power to the control system 70, and more particularly to the microcontroller 424. Other start conditions are also contemplated as falling within the scope of the invention such as, for example, a proper credential provided to a reader associated with the exit device 10. In the illustrated embodiment, power is not directly transmitted to the motor 410. Instead, the microcontroller 424 administers power for the power-based functions of the exit device 10, which also includes relaying power to the motor 410. In one embodiment, the power supply is an external power supply that is in turn connected to a 120/240 VAC source. However, it should be understood that other conventional methods of supplying power also fall within the scope of the invention.

**[0042]** As the motor 410 retracts the motor shaft 412, the guide pin 483 urges the spring 202 toward the motor 410. The pre-loaded spring 202 resists relative motion of the link 200 and the motor shaft 412, and motion of the guide pin 483 toward the motor 410 results in the spring 202 urging the end wall 240 toward the motor 410 substantially without further compression of the spring 202. As such, substantially all motion of the motor shaft 412 is translated to the link 200. It is also contemplated that that the spring 202 may deform slightly such that there is not a one to one correlation of movement of the motor shaft 412 and the link 200. As the link 200 travels from the extended position to the retracted position, the beam 196 is pulled toward the motor 410, thereby causing the pushbar 25 and the latch bolt 30 to move toward their unlocked or inner states.

**[0043]** FIG. 9 illustrates the motor shaft 412 in the unlocking position. With the motor shaft 412 in the unlocking position, the link 200 is in a retracted position, and the pushbar 25 and the latch bolt 30 are positioned in their inner states. In this configuration, the pushbar 25 may be in contact with the base plate 115 or the stops, such that further retraction of the pushbar 25, and thus of the shaft 160, is prevented. When the shaft 160 reaches the end of its travel, the link 200 cannot continue to move toward the motor 410. As the motor 410 continues to retract the motor shaft 412, the guide pin 483 travels along the slot 232, thereby further compressing the spring 202 as the motor shaft moves toward the over-travel position (FIG. 10).

**[0044]** FIG. 10 depicts the motor shaft 412 in the over-travel position. With the motor shaft 412 in the over-travel position, the spring 202 is compressed beyond the pre-loading compression, and the motor shaft 412 is in close proximity to the sensor 425. When the motor shaft 412 reaches the over-travel position and is detected by the sensor 425, the sensor 425 sends a stop

signal to the microcontroller 424. In the illustrated embodiment, the sensor 425 is a solid state switch configured to send the stop signal when the motor shaft 412 is detected by the sensor 425. However, other sensor and sensor configurations are also contemplated. Upon receiving the stop signal, the microcontroller 424 enters a holding operation wherein the power supplied to the motor 410 is reduced to a holding power sufficient to hold the link 200 in the retracted position against the biasing force of the springs 195, 202. After a predetermined time has elapsed, the microcontroller 424 cuts power to the motor, and the springs 195, 202 urge the link 200 toward the extended position, the motor shaft 412 toward the locking position, and the pushbar 25 and latch bolt 30 toward their outer states.

**[0045]** In the illustrated embodiment, the microcontroller 424 enters the holding operation upon receiving a stop signal, which is generated when the motor shaft 412 is in close proximity to the sensor 425. It is also contemplated that that the microcontroller 424 may stop the motor 410 based upon additional or alternative stop conditions. For example, the sensor 425 may sense the current being drawn by the motor, and the microcontroller 424 may interpret a threshold current as the stop condition. In further embodiments, the control module 420 does not necessarily have to include a sensor 425, and the microcontroller 424 may terminate operation of the motor 410 after a predetermined time has elapsed, or after a predetermined number of pulses have been sent to the motor 410.

**[0046]** In certain embodiments in which the sensor 425 is utilized, the sensor 425 may be configured as a Hall effect sensor cooperating with a magnet mounted on the end of the motor shaft 412. The Hall effect sensor generates a voltage signal indicative of the distance between the sensor 425 and the magnet, which signal may be interpreted by the microcontroller 424 as the position of the motor shaft 412. In such embodiments, the stop condition may be a threshold level of the voltage signal indicating the motor shaft 412 is in the over-travel position. In embodiments in which the sensor 425 is a Hall effect sensor, the voltage signal may also be utilized by the microcontroller 424 in additional or alternative procedures, such as anti-tampering procedures, procedures for reacting to external and/or environmental agents, and/or one or more responses to door slam conditions. Illustrative forms of such additional procedures are described in commonly-owned U.S. Patent No. 8,182,003 to Dye et al., column 12, line 43 through column 14, line 18 and FIGS. 1A-1C, 2, and 9, the contents of which are incorporated herein by reference.

**[0047]** Regardless of the precise stop condition utilized by the microcontroller 424, the over-travel assembly 199 provides an extended range in which the link 200 is in the retracted position and the motor 410 can continue to operate without stalling. Because the motor shaft 412 can continue to travel inward despite the fact that latch bolt 30 is fully retracted, this range may be considered an over-travel window. In embodiments which utilize a solenoid in place of the motor 410, this over-travel window enables the plunger to reach the end of its travel where it has the highest holding force. Whatever type of actuating system is used, the over-travel window enables increased tolerances during manufacture and installation, and may obviate the need for repositioning and/or recalibration of the elements and features of the control system 70.

**[0048]** As can be seen from the foregoing, the over-travel assembly 199 translates motion of the motor shaft 412 to motion of a locking member. In the illustrated form, the exit device 10 is a rim-type exit device, and the locking member is the latch bolt 30. However, it is also contemplated that the over-travel assembly 199 may be utilized in other forms of exit devices such as, for example, a mortise lock or a remote latching system which may be, for example, of the surface vertical type or the concealed vertical type. In remote latching systems, the locking member may be a latch or a bolt which protrudes from the upper, lower, or side surface of the door 15 when the motor shaft 412 is in the locked position. Furthermore, the exit device may be of the multipoint latching type which may include a plurality of latches or bolts.

**[0049]** While the locking members described herein include latches and bolts, it is also contemplated that the locking member may be of another form. For example, in certain embodiments, the exit device may be a delayed egress exit device such as, for example, the type described in commonly-owned U.S. Patent No. 5,085,475 to Austin et al., and the locking member may be a blocking member connected to the beam 196. The blocking member may be operable in a blocking position wherein retraction of the latch bolt 30 is prevented and an unblocking position wherein retraction of the latch bolt 30 is enabled. In one such embodiment, pushing the pushbar 25 to the inner state causes a sensor to send a signal to the microcontroller 424, thereby indicating that a user is attempting to operate the exit device 10. Upon receiving the signal, the microcontroller 424 does not supply power to the motor 410 until a predetermined delay time has elapsed. During this delay time, the microcontroller 424 may trigger an alarm such as, for example, an audible alarm which indicates that a person is attempting to open the door 15. Once the microcontroller 424 provides power to the motor 410, the over-travel

assembly 199 functions as described above, and the beam 196 moves the blocking member from the blocking position to the unblocking position. Once the blocking member is in the unblocking position, the latch bolt 30 can retract and the door 15 can be opened. In such delayed egress embodiments, the over-travel window provided by the over-travel assembly 199 ensures that the blocking member moves fully into the blocking or unblocking position, while providing the previously-described increased tolerances and benefits associated therewith.

**[0050]** Certain forms of the over-travel assembly 199 may include additional or alternative features. For example, with reference to FIGS. 5-7, the over-travel assembly 199 may include dogging features that allow a user to selectively retain the latch bolt 30 in the inner position such that the door 15 remains unlocked. The link 200 may include a dogging tab 224 extending outward (i.e., in the direction of movement of the pushbar 25 from the inner state to the outer state) through a slot 324 in the housing 300. The housing 300 may also include an opening 326 for mounting a dogging arm operable in a dogged state and an undogged state. In the dogged state, the dogging arm engages the dogging tab 224, thereby retaining the link 200 in the retracted position and the latch bolt 30 in the inner or unlocked state. In the undogged state, the dogging arm does not engage the dogging tab 224, and the link 200 is free to move between the extended and retracted positions. A spring may have one end connected to a tab 328 and the other end connected to the dogging arm such that the dogging arm is biased toward the dogged position or the undogged position.

**[0051]** In other forms, the over-travel assembly 199 may include features to provide the exit device 10 with improved resistance to tampering. FIGS. 11 and 12 depict an illustrative embodiment of such a tamper-resistant over-travel assembly 199'. The over-travel assembly 199' includes a housing 500, a link 600, and a bracket 700. The housing 500 and link 600 are substantially similar to the previously-described housing 300 and link 200, and similar reference characters are used to denote similar elements. In the interest of clarity, the following description focuses primarily on features which are different than those previously described.

**[0052]** In the link 600 of the illustrated embodiment, the arms 630 include depending portions 650 which define the openings 651. Each of the openings 651 includes a slotted portion 652 configured to slidably receive a blocking pin 495, and an enlarged portion 654 defined in part by a ramp 656 and a ridge 658. The functions of the ramp 656 and the ridge 658 are described in further detail below.

**[0053]** The bracket 700 includes side walls 710 including apertures (not labeled), and arms 720 extending toward the beam 196. The bracket 700 is pivotably mounted to the housing 500 by a pivot pin 484 extending through a first set of apertures in the housing 500 and the side walls 710. The bracket 700 is also slidingly coupled to the link 600 by a blocking pin 485 extending through the openings 651, a second set of apertures formed in the side walls 710, and slots 502 in the housing 500. The slots 502 limit the pivotal range of the bracket 700 by limiting the range of motion of the blocking pin 485. Each of the arms 720 defines a channel 721 including a mouth 722, a first slot 723, and a second slot 724.

**[0054]** FIG. 11 depicts the motor shaft 412 in the locked position, the link 600 in an extended position, and the bracket 700 in a home position. When the bracket 700 is in the home position, the first slot 723 is aligned with the slot 632 in the arm 630. In a manner similar to that described above with reference to FIGS. 8-10, movement of the motor shaft 412 from the locking position toward the unlocking position causes the link 600 to move from the extended position toward a retracted position (FIG. 12). If the bracket 700 is not in the home position when the motor shaft 412 begins retracting, the guide pin 483 engages the tapered surface of the mouth 722, thereby causing the bracket 700 to pivot into the home position. As the link 600 moves from the extended position to the retracted position, the blocking pin 485 travels into the enlarged portion 654 where the ramp 656 may urge the blocking pin 485 into alignment with the ridge 658. As the motor 410 continues to retract the shaft 412, the guide pin 483 travels along a ramp 725 toward the second slot 724, thereby causing the bracket 700 to pivot to a rotated position (FIG. 12) in which the second slot 724 is aligned with the arm slot 623. The guide pin 483 continues to travel along the second slot 724 as the motor shaft 412 continues to move toward the over-travel position.

**[0055]** FIG. 12 depicts the motor shaft 412 in the over-travel position, the link 600 in the retracted position, and the bracket 700 in the rotated position. When the motor shaft 412 is in the over-travel position, the pin 485 is aligned with the ridge 658. If a person attempts to force the pushbar 25 from the inner state toward the outer state, the beam 196 transmits such force to the link 600. The tampering force is transmitted from the link 600 to the bracket 700 (due to engagement of the ridge 658 and the blocking pin 485), which, due to its fixed longitudinal position with respect to the housing 500, prevents movement of the link 600. The fixed

longitudinal position of the link 600 prevents movement of the beam 196, which in turn prevents movement of the pushbar 25 and the latch bolt 30 toward their outer or locked positions.

**[0056]** Once the microcontroller 424 determines that the latch bolt 30 should be returned to its outer state such as, for example, upon receiving a command from the user, or after a predetermined amount of time has elapsed since the latch-retracting operation, the microcontroller 424 supplies power to the motor 410 such that the motor 410 runs in reverse. Reverse operation of the motor 410 causes the motor shaft 412 to move from the over-travel position toward the unlocked position, thereby moving the guide pin 483 along the link slot 632 and the second bracket slot 724. When the guide pin 483 reaches the end of the second bracket slot 724, it engages a second ramp 726, thereby urging the bracket 700 from the rotated position toward the home position. This in turn causes the blocking pin 485 to travel along the housing slots 502 to a position in which the blocking pin 485 is no longer aligned with the ridge 658. In this position of the blocking pin 485, the link 600 is free to move from the retracted position to the extended position as the blocking pin 485 can be received in the slotted portion 652 of the opening 651. Continued movement of the motor shaft 412 toward the locking position causes the latch bolt 30 to move toward the outer state, at which point the door 15 is locked.

**[0057]** While the invention has been illustrated and described in detail in the drawings and foregoing description, the same is to be considered as illustrative and not restrictive in character, it being understood that only the preferred embodiments have been shown and described, and that all changes and modifications that come within the spirit of the inventions are desired to be protected. It should be understood that while the use of words such as preferable, preferably, preferred or more preferred utilized in the description above indicate that the feature so described may be more desirable, it nonetheless may not be necessary and embodiments lacking the same may be contemplated as within the scope of the invention, the scope being defined by the claims that follow. In reading the claims, it is intended that when words such as “a,” “an,” “at least one,” or “at least one portion” are used there is no intention to limit the claim to only one item unless specifically stated to the contrary in the claim. When the language “at least a portion” and/or “a portion” is used the item can include a portion and/or the entire item unless specifically stated to the contrary.

## CLAIMS

1. An exit device, comprising:

a link having an extended link position and a retracted link position, the link including a dogging tab operable to engage a dogging arm configured to retain the link in the retracted link position;

a housing mounted adjacent the link, the housing including a mounting location at which the dogging arm is operable to be mounted to the housing, and a longitudinal slot through which the dogging tab extends;

a locking member having an extended state and a retracted state, wherein the locking member is connected to the link and is configured to assume the extended state in response to the extended link position and is configured to assume the retracted state in response to the retracted link position;

a motor shaft slidingly connected to the link and having a locking position, an over-travel position, and an unlocking position between the locking position and the over-travel position;

a spring transmitting force between the motor shaft and the link, wherein the spring is preloaded and resists relative movement between the motor shaft and the link;

a motor operable to drive the motor shaft between the locking, unlocking, and over-travel positions;

a sensor configured to issue a stop signal in response to the over-travel position of the motor shaft; and

a controller configured to transmit a driving power to the motor in response to a start signal, and to transmit a holding power to the motor in response to the stop signal; and

wherein the motor is configured to drive the motor shaft from the locking position toward the over-travel position in response to the driving power, and to discourage the motor shaft from moving toward the locking position in response to the holding power.

2. The exit device of claim 1, wherein the motor is configured to retain the motor shaft in the over-travel position in response to the holding power.

3. The exit device of claim 1, wherein the sensor is a switch, and is configured to issue the stop signal in response to detecting the motor shaft in the over-travel position.

4. The exit device of claim 1, further comprising a magnet mounted on the motor shaft, wherein the sensor is a Hall effect sensor configured to generate voltage signals indicative of a distance between the sensor and the magnet, and the stop signal comprises a voltage signal exceeding a threshold value.

5. The exit device of claim 1, wherein the locking member comprises a latch bolt having an extended latch bolt position and a retracted latch bolt position, the extended state includes the extended latch bolt position, and the retracted state includes the retracted latch bolt position.

6. The exit device of claim 5, further comprising a pushbar having an outer state and an inner state, wherein the pushbar is connected to the latch bolt, and wherein the latch bolt is configured to move from the extended latch bolt position to the retracted latch bolt position in response to movement of the pushbar from the outer state to the inner state.

7. The exit device of claim 6, wherein the pushbar is coupled to the link via a lost motion connection, wherein the lost motion connection is configured to enable the pushbar to move from the outer state to the inner state without moving the link from the extended link position, and to move the pushbar from the outer state toward the inner state in response to movement of the link from the extended link position toward the retracted link position.

8. The exit device of claim 5, wherein the link includes a slot having a length extending in a longitudinal direction, and the motor shaft is slidably coupled to the link by a guide pin slideable along the slot, the exit device further comprising:

a housing having a fixed position with respect to the motor; and

a bracket pivotably mounted to the housing and having an unblocking position in which the bracket permits movement of the link from the retracted link position toward the extended

link position, and a blocking position in which the bracket prevents movement of the link from the retracted link position toward the extended link position.

9. The exit device of claim 8, wherein the bracket is configured to move between the blocking position and the unblocking position in response to movement of the motor shaft between the unlocking position and the over-travel position.

10. The exit device of claim 9, wherein the link includes an opening defined in part by a blocking ridge;

wherein the bracket includes a channel comprising a first slotted portion, a second slotted portion, and a ramp connecting the first and second slotted portions;

the exit device further comprising a blocking pin coupled to the bracket and extending through the opening;

wherein, in the unblocking position of the bracket, the first slotted portion is aligned with the slot such that the guide pin is slideable along the first slotted portion, and the blocking pin is not aligned with the blocking ridge;

wherein, in the blocking position of the bracket, the second slotted portion is aligned with the slot, the guide pin is slideable along the second slotted portion, and the blocking pin is aligned with the blocking ridge; and

wherein engagement of the guide pin and the ramp moves the bracket between the unblocking position and the blocking position as the guide pin travels along the slot.

11. The exit device of claim 1, further comprising:

a latch bolt having an extended position and a retracted position;

a pushbar having an outer state and an inner state;

a second sensor configured to issue a request signal in response to the inner state of the pushbar; and

wherein the locking member comprises a blocking member having a blocking position in which retraction of the latch bolt is prevented and an unblocking position in which retraction of the latch bolt is enabled;

wherein one of the extended state and the retracted state comprises the blocking position, and the other of the extended state and the retracted state comprises the unblocking position; and

wherein, in response to the request signal, the controller is configured to selectively power the motor to retain the blocking member in the blocking position for a predetermined delay time, and to thereafter allow the blocking member to move to the unblocking position.

12. The exit device of claim 11, wherein the controller is configured to transmit power to the motor after the predetermined delay time has elapsed.

13. An exit device, comprising:

a base plate configured for mounting on a door;

a longitudinally movable link including a first longitudinal slot, the link including a dogging tab operable to engage a dogging arm to retain the link in a predetermined position;

a locking member having a first locking member position and a second locking member position, wherein the locking member is connected to the link and is configured to move between the first and second locking member positions in response to longitudinal movement of the link;

a housing coupled to the base plate, the housing including a second longitudinal slot aligned with the first longitudinal slot, a third longitudinal slot through which the dogging tab extends, and an aperture for mounting the dogging arm to the housing;

a longitudinally movable motor shaft including an opening aligned with the first and second longitudinal slots;

a pin extending through the first longitudinal slot, the second longitudinal slot, and the opening in the motor shaft, thereby coupling the motor shaft, the link, and the housing;

an elastic member transmitting force between the motor shaft and the link, wherein the elastic member is compressed between the pin and the link;

a motor engaged with the motor shaft; and

a controller configured to selectively transmit to the motor a driving power and a holding power;

wherein the motor is configured to rotate a rotor in response to the driving power, the motor shaft is configured to move longitudinally in response to rotation of the rotor, and the elastic member longitudinally urges the link in response to longitudinal movement of the motor shaft; and

wherein the motor is configured to inhibit longitudinal movement of the motor shaft in response to the holding power.

14. The exit device of claim 13, further comprising:

a pushbar having an outer position and an inner position; and

a sensor configured to transmit a request signal to the controller in response to the inner position of the pushbar; and

wherein the controller is configured to selectively power the motor to retain the locking member in the first locking member position for a predetermined delay time after the request signal, and to thereafter allow the locking member to move to the second locking member position.

15. The exit device of claim 14, wherein the controller is configured to transmit no power to the motor during the predetermined delay time, and to thereafter transmit the driving power.

16. An exit device, comprising:

a mounting assembly;

a pushbar movably mounted to the mounting assembly, the pushbar having a projected position and a depressed position;

a latchbolt operably movably mounted to the mounting assembly, the latchbolt having an extended position and a retracted position, wherein the latchbolt is operably connected with the pushbar and is configured to move from the extended position toward the retracted position in response to movement of the pushbar from the projected position toward the depressed position;

a blocking member having a blocking position in which the blocking member retains the latchbolt in the extended position and an unblocking position in which the latchbolt is movable toward the retracted position;

an output shaft coupled with the blocking member, the output shaft having a first output shaft position a second output shaft position, wherein the first output shaft position corresponds to one of the blocking position or the unblocking position, and wherein the second output shaft position corresponds to the other of the blocking position or the unblocking position;

a link coupled with the output shaft;

an input shaft slidably coupled with the link;

a preloaded spring compressed between the input shaft and the link; and

a linear actuator operable to drive the input shaft between a first input shaft position, a second input shaft position, and a third input shaft position, wherein the second input shaft position is between the first input shaft position and the third input shaft position;

wherein movement of the input shaft from the first input shaft position to the second input shaft position causes the link to drive the output shaft from the first output shaft position to the second output shaft position, thereby moving the blocking member from the one of the blocking position or the unblocking position to the other of the blocking position or the unblocking position; and

wherein movement of the input shaft from the second input shaft position to the third input shaft position causes the input shaft to further compress the spring while the output shaft remains in the second output shaft position.

17. The exit device of claim 16, further comprising:

a controller in communication with the actuator and operable to cause the linear actuator to move the input shaft from the first input shaft position to the third input shaft position; and

a sensor configured to send a request signal in response to movement of the pushbar from the projected position toward the depressed position; and

wherein, in response to the request signal, the controller is configured to selectively power the linear actuator to retain the blocking member in the blocking position for a predetermined delay time, and to thereafter move the blocking member to the unblocking position.

18. The exit device of claim 17, wherein the controller is configured to supply no power to the linear actuator during the predetermined delay time, and to thereafter supply the linear actuator with driving power.

19. The exit device of claim 16, wherein the linear actuator comprises a rotary motor.

20. The exit device of claim 19, wherein the motor is a stepper motor.

21. The exit device of claim 16, wherein the first output shaft position corresponds to the blocking position, and wherein the second output shaft position corresponds to the unblocking position.

22. The exit device of claim 16, further comprising a housing mounted to the mounting assembly and including a first longitudinal slot;  
wherein the link includes a second longitudinal slot;  
wherein the input shaft comprises an opening; and  
wherein a pin extends through the first longitudinal slot, the second longitudinal slot, and the opening to thereby prevent rotation of the input shaft relative to the housing.

23. An exit device, comprising:  
a latchbolt having an extended position and a retracted position;  
a pushbar operably connected with the latchbolt such that movement of the pushbar from a projected position toward a depressed position causes movement of the latchbolt from the extended position toward the retracted position;  
a sensor configured to transmit a request signal in response to movement of the pushbar from the projected position toward the depressed position;  
a blocking member having a blocking position and an unblocking position, wherein the blocking member is configured to prevent retraction of the latchbolt when in the blocking position and to permit retraction of the latchbolt when in the unblocking position;  
a linear actuator operable to move an input shaft between a start position and an end position, the input shaft having an intermediate position between the start position and the end position;

a preloaded spring connected between the input shaft and the blocking member, wherein the spring is configured to drive the blocking member from the blocking position to the unblocking position as the input shaft moves from the start position to the intermediate position, and to retain the blocking member in the unblocking position as the input shaft moves from the intermediate position to the end position; and

a controller in communication with the sensor and the linear actuator, wherein the controller is configured to transmit a driving power to the linear actuator in response to receiving the request signal from the sensor;

wherein the linear actuator is configured to drive the input shaft from the start position toward the end position in response to receiving the driving power.

24. The exit device of claim 23, wherein the controller is configured to delay transmission of the driving power for a predetermined delay time following receipt of the request signal.

25. The exit device of claim 23, wherein the linear actuator comprises a rotary motor.

26. The exit device of claim 25, wherein the motor is a stepper motor, and wherein the driving power comprises a series of electrical pulses.

27. The exit device of claim 23, further comprising an output shaft coupled with the blocking member, and a link coupled with the output shaft, wherein the spring is engaged between the link and the input shaft.

28. The exit device of claim 27, further comprising a housing including a first longitudinal slot;

wherein the link includes a second longitudinal slot;

wherein the input shaft comprises an opening; and

wherein a pin extends through the first longitudinal slot, the second longitudinal slot, and the opening to thereby prevent rotation of the input shaft relative to the housing.

29. The exit device of claim 23, further comprising a second sensor configured to transmit a stop signal in response to the input shaft reaching the end position; and wherein the controller is configured to terminate transmission of the actuating signal in response to receiving the stop signal.

30. An exit device, comprising:

a latchbolt having an extended position and a retracted position;

a pushbar;

a sensor configured to transmit a request signal in response to movement of the pushbar from a projected position toward a depressed position;

a blocking member configured to prevent retraction of the latchbolt when in a blocking position and to permit retraction of the latchbolt when in an unblocking position;

a linear actuator operable to move a first shaft between a start position and an end position, the first shaft having an intermediate position between the start position and the end position;

a preloaded spring connected between the first shaft and the blocking member, wherein the spring is configured to drive the blocking member from the blocking position to the unblocking position as the first shaft moves from the start position to the intermediate position, and to retain the blocking member in the unblocking position as the first shaft moves from the intermediate position to the end position; and

a controller in communication with the sensor and the linear actuator, wherein the controller is configured to transmit a driving power to the linear actuator in response to receiving the request signal from the sensor;

wherein the controller is configured to delay transmission of the driving power for a predetermined delay time following receipt of the request signal; and

wherein the linear actuator is configured to drive the first shaft from the start position toward the end position in response to receiving the driving power.

31. The exit device of claim 30, wherein the linear actuator comprises a rotary motor.

32. The exit device of claim 31, wherein the motor is a stepper motor, and wherein the driving power comprises a series of electrical pulses.

33. The exit device of claim 30, further comprising a second shaft coupled with the blocking member, and a link coupled with the second shaft, wherein the spring is engaged between the link and the first shaft.

34. The exit device of claim 30, further comprising a housing including a first longitudinal slot;

wherein the link includes a second longitudinal slot;

wherein the first shaft comprises an opening; and

wherein a pin extends through the first longitudinal slot, the second longitudinal slot, and the opening to thereby prevent rotation of the first shaft relative to the housing.

35. The exit device of claim 30, further comprising an additional sensor, the additional sensor configured to transmit a stop signal in response to the first shaft reaching the end position; and

wherein the controller is configured to terminate transmission of the driving power in response to receiving the stop signal.

36. A method of operating an exit device including a pushbar and a latchbolt, the method comprising:

selectively maintaining a blocking member in a blocking position in which the blocking member prevents the pushbar from retracting the latchbolt;

transmitting a request signal from a sensor in response to movement of the pushbar from an outer state to an inner state;

in response to the request signal, initiating a delay timer; and

in response to expiration of the delay timer, supplying power to an actuator, thereby causing the actuator to move a shaft from a start position to an end position;

wherein the shaft has an intermediate position located between the start position and the end position;

wherein the shaft is connected to the blocking member via an over-travel assembly including a link coupled to the blocking member and a spring engaged between the shaft and the link;

wherein movement of the shaft from the start position to the intermediate position drives the link from a first link position to a second link position, thereby causing the link to drive the blocking member from the blocking position to the unblocking position; and

wherein movement of the shaft from the intermediate position to the end position deforms the spring such that the link remains in the second link position and the blocking member remains in the unblocking position.

37. The method of claim 36, wherein the exit device further comprises a controller in communication with the sensor and the actuator;

wherein the controller is configured to initiate the delay timer in response to receiving the request signal; and

wherein the controller is configured to supply the power to the actuator in response to expiration of the delay timer.

38. The method of claim 36, wherein the actuator comprises a rotary motor, and wherein the rotary motor is configured to drive the shaft linearly between the start position and the end position.

39. The method of claim 36, further comprising triggering an alarm during the delay timer.

40. The method of claim 36, further comprising transmitting a stop signal from a second sensor in response to the shaft reaching the end position, and cutting power to the actuator in response to the stop signal.

41. The method of claim 36, wherein the actuator comprises a stepper motor, and wherein supplying power to the actuator comprises supplying a series of electrical pulses to the stepper motor.

42. A delayed egress exit device, comprising:

a pushbar;

a sensor configured to transmit a request signal in response to actuation of the pushbar;

a controller configured to initiate a delay timer in response to receipt of the request signal, and to transmit an actuating signal in response to expiration of the delay timer;

a linear actuator configured to move a shaft from a start position to an end position in response to receipt of the actuating signal, wherein the shaft has an intermediate position between the start position and the end position;

a latchbolt having an extended position and a retracted position;

a blocking member having a blocking position in which the blocking member retains the latchbolt in the extended position, and an unblocking position in which the blocking member permits movement of the latchbolt between the extended position and the retracted position; and

a spring connected between the shaft and the blocking member, wherein movement of the shaft from the start position to the intermediate position drives the blocking member from the blocking position to the unblocking position, and wherein movement of the shaft from the intermediate position to the end position compresses the spring while the blocking member remains in the unblocking position.

43. The delayed egress exit device of claim 42, wherein the controller is further configured to activate an alarm in response to receipt of the request signal.

44. The delayed egress exit device of claim 42, further comprising a link engaged with the spring and connected with the blocking member.

45. The delayed egress exit device of claim 44, further comprising a housing configured to limit the link to linear movement between a first position corresponding to the blocking position, and a second position corresponding to the unblocking position.

46. The delayed egress device of claim 45, wherein the link includes a flange that extends through a slot in the housing; and

wherein the housing includes a mounting aperture for mounting a dogging mechanism operable to retain a position of the link by engaging the flange.

47. The delayed egress exit device of claim 42, wherein the controller does not activate the linear actuator during the delay timer.

48. The delayed egress exit device of claim 42, wherein the linear actuator comprises a rotary motor.

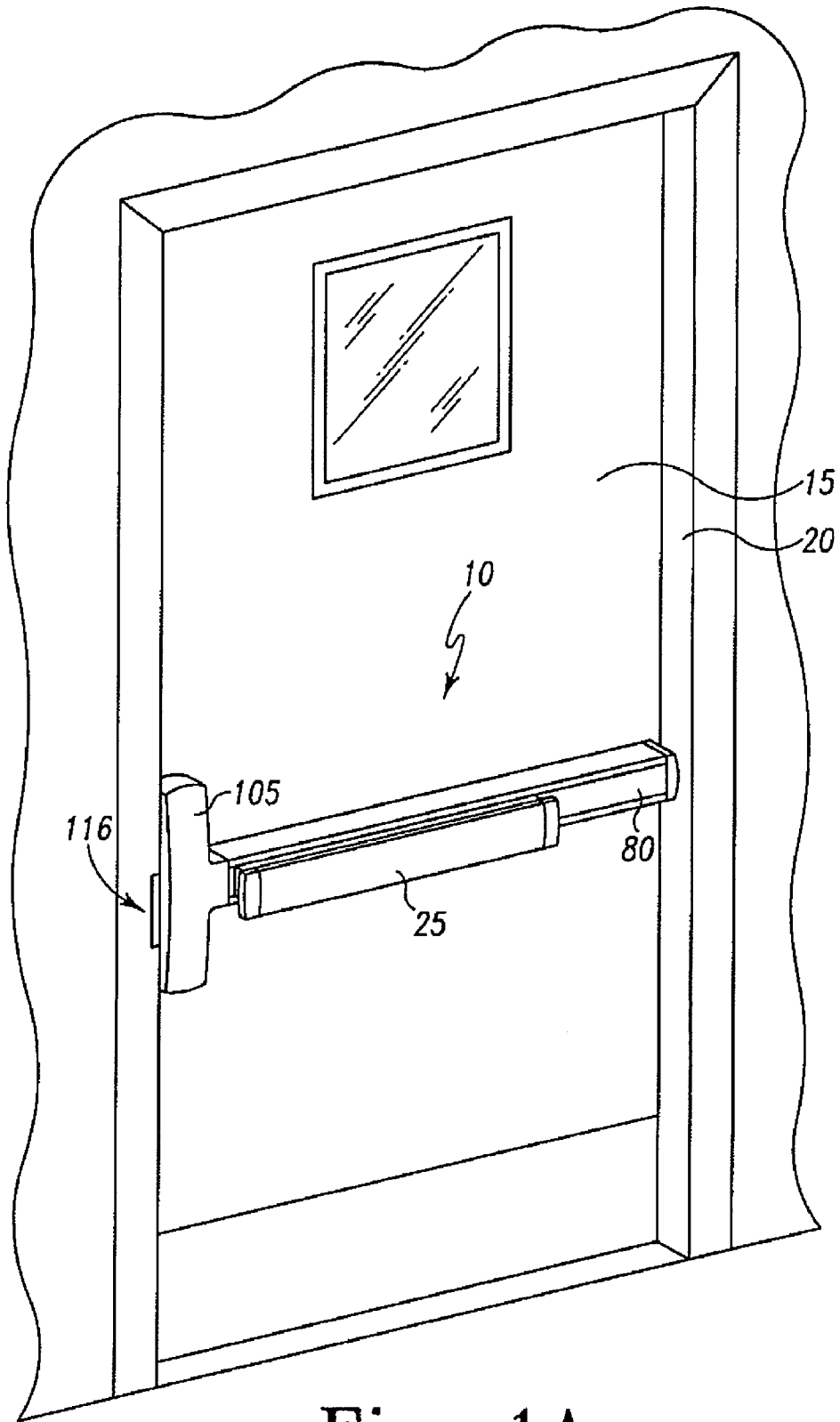


Fig. 1A

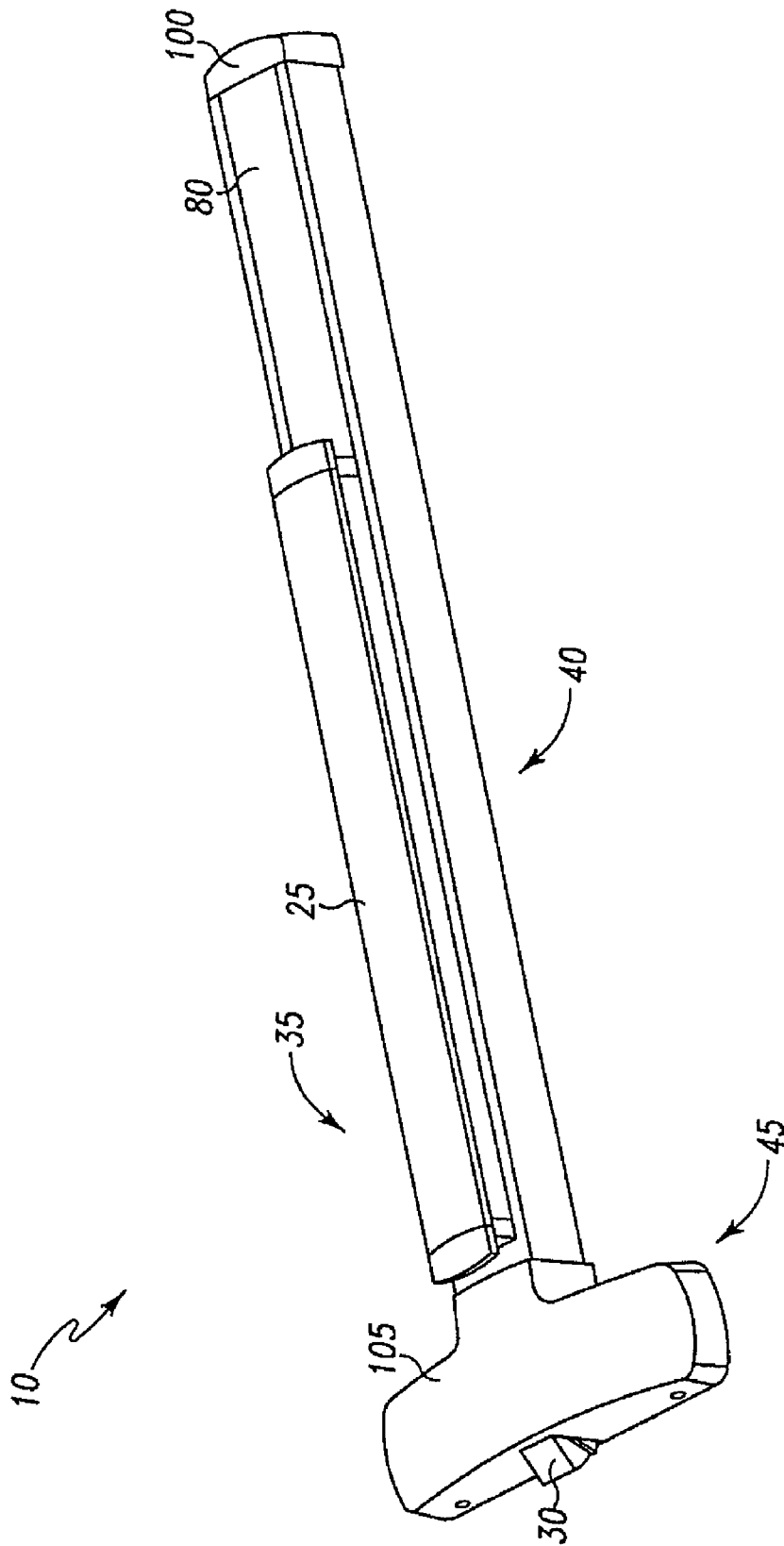


Fig. 1B

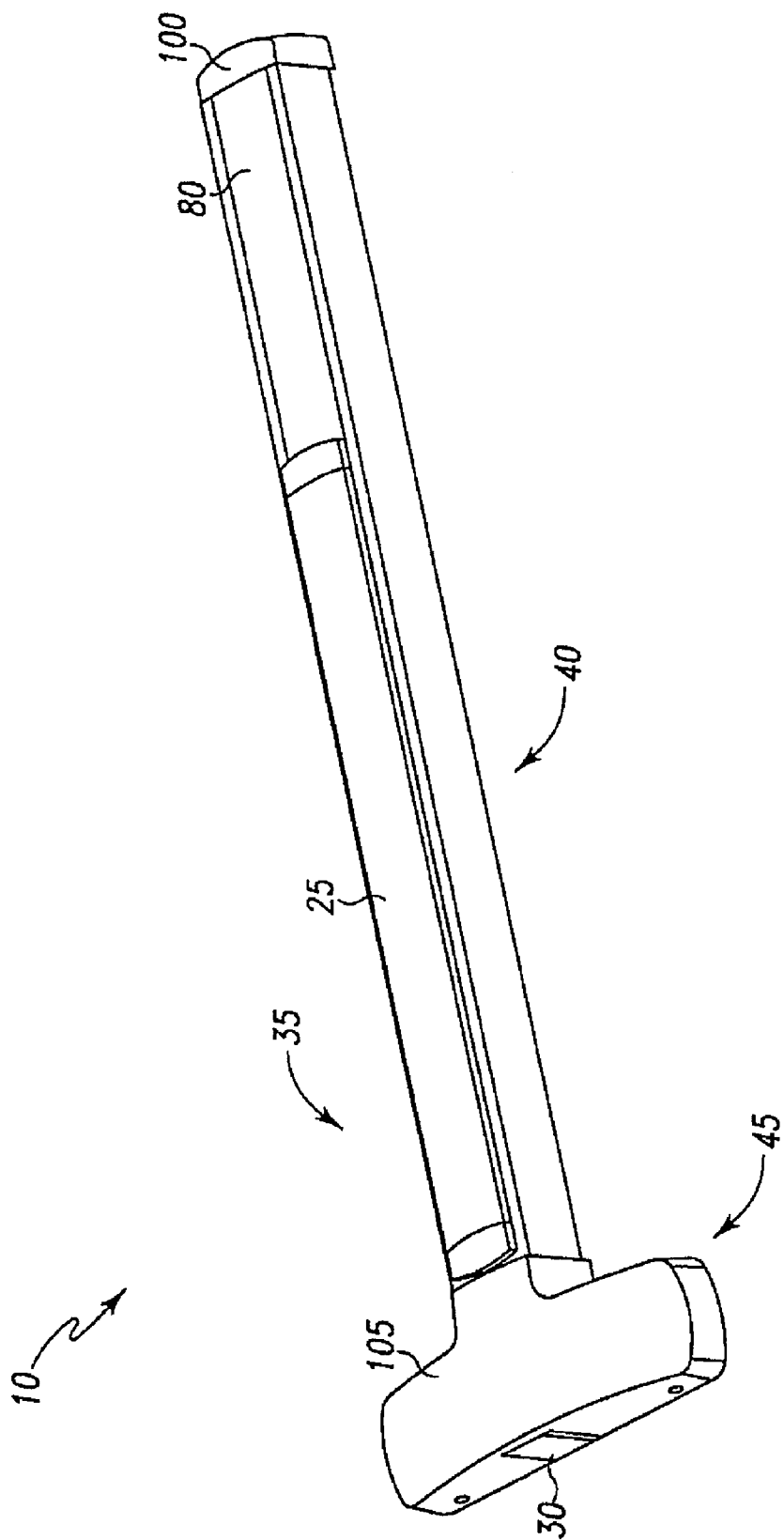


Fig. 1C

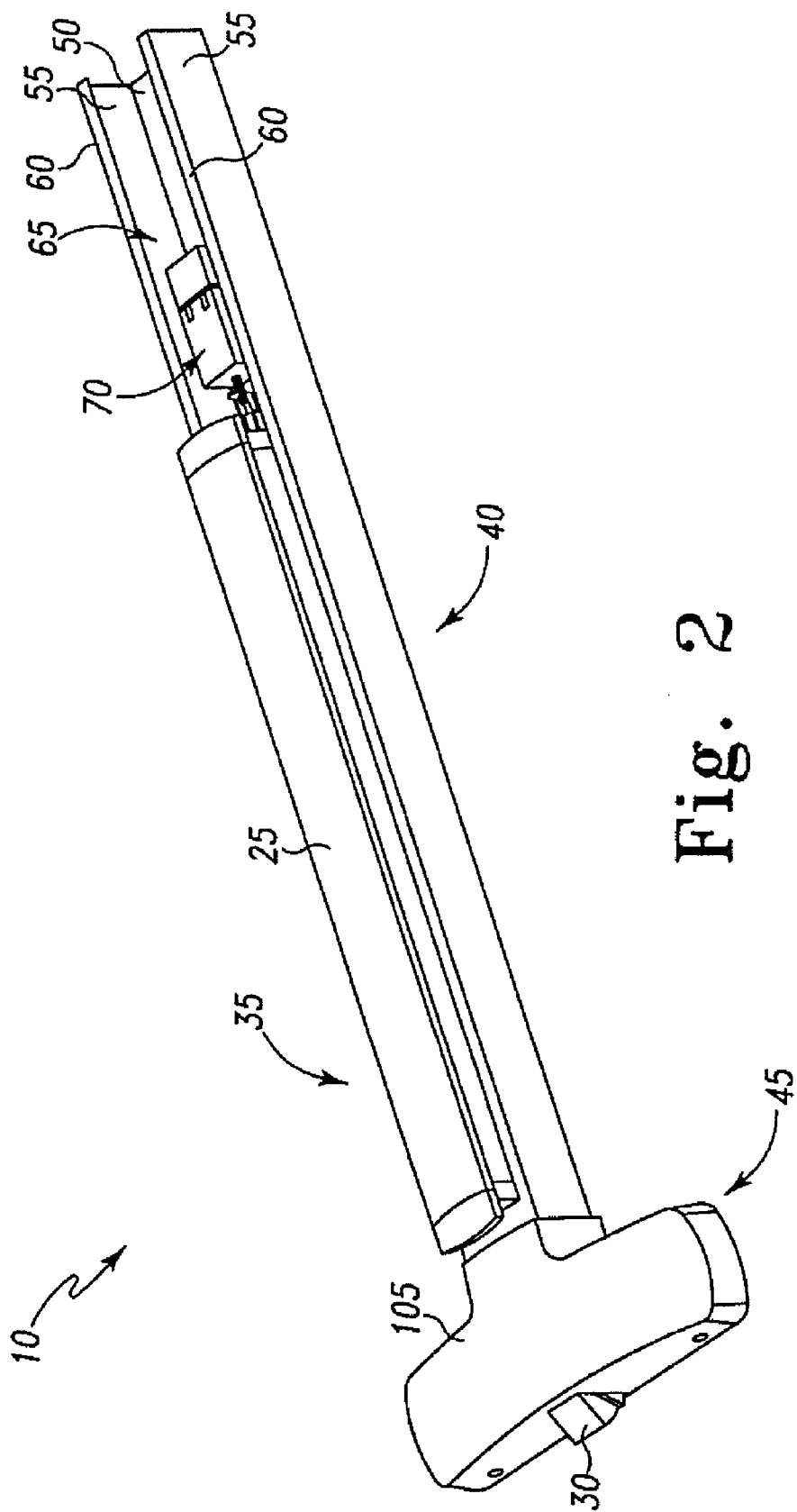


Fig. 2

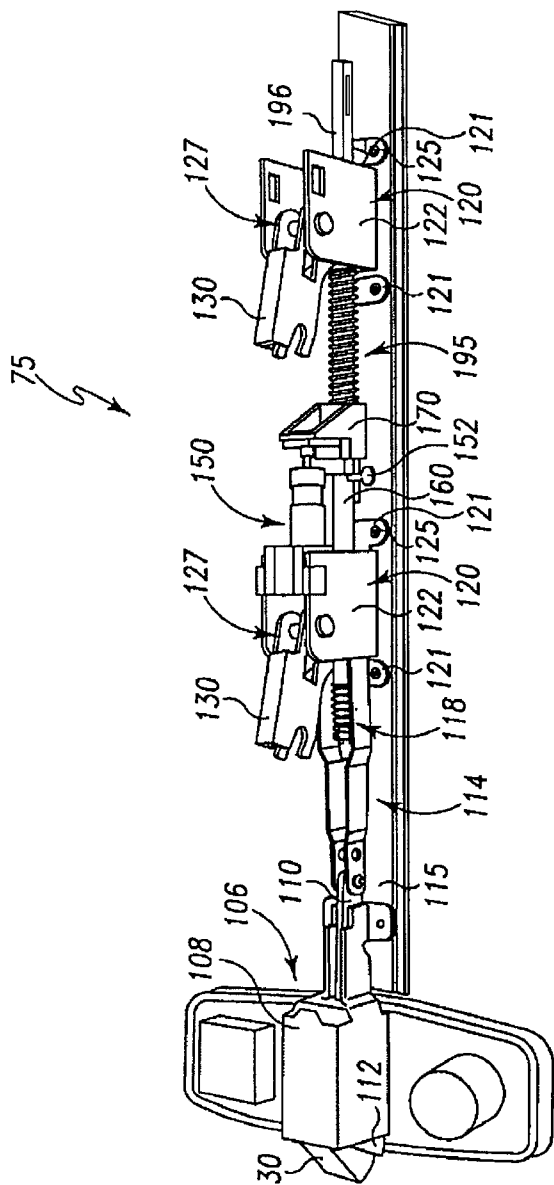


Fig. 3

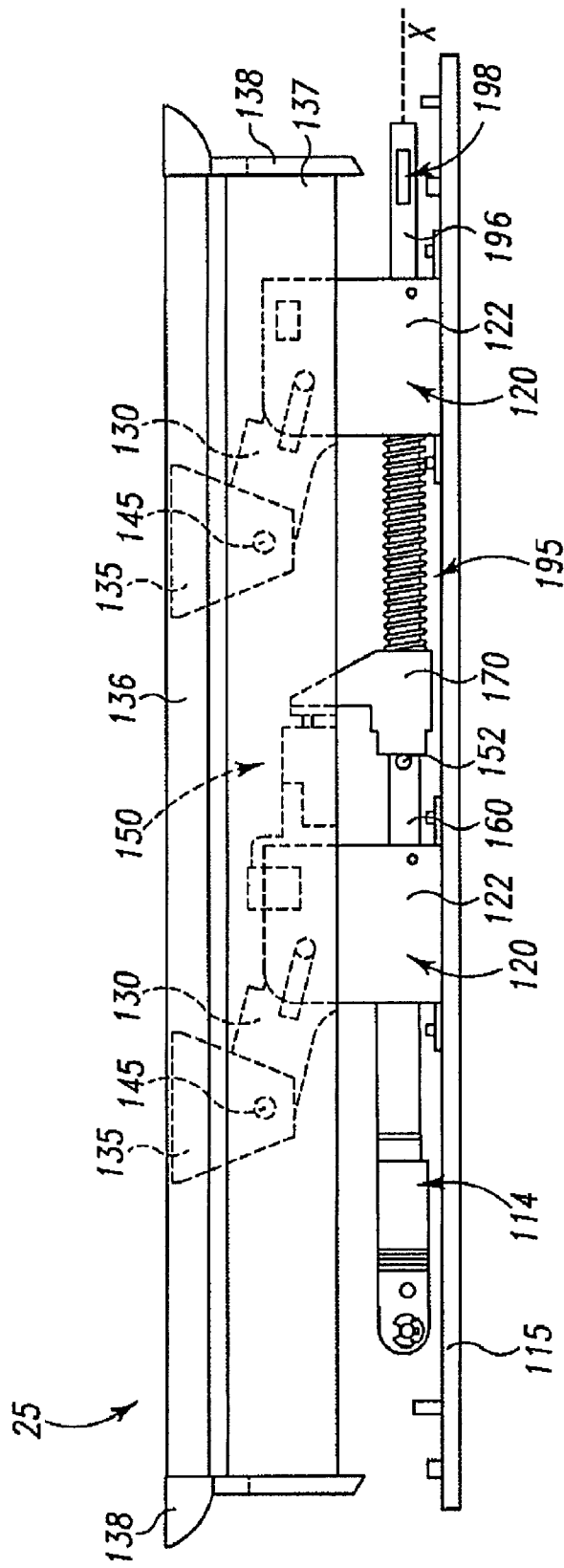
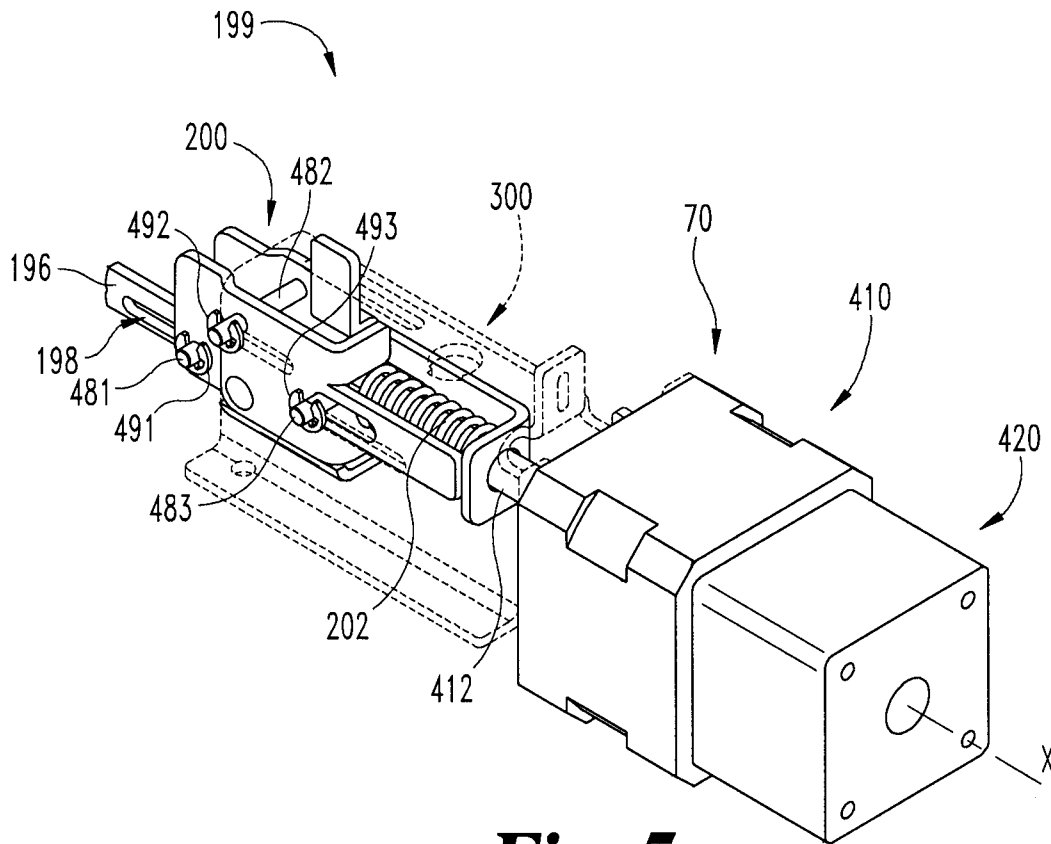
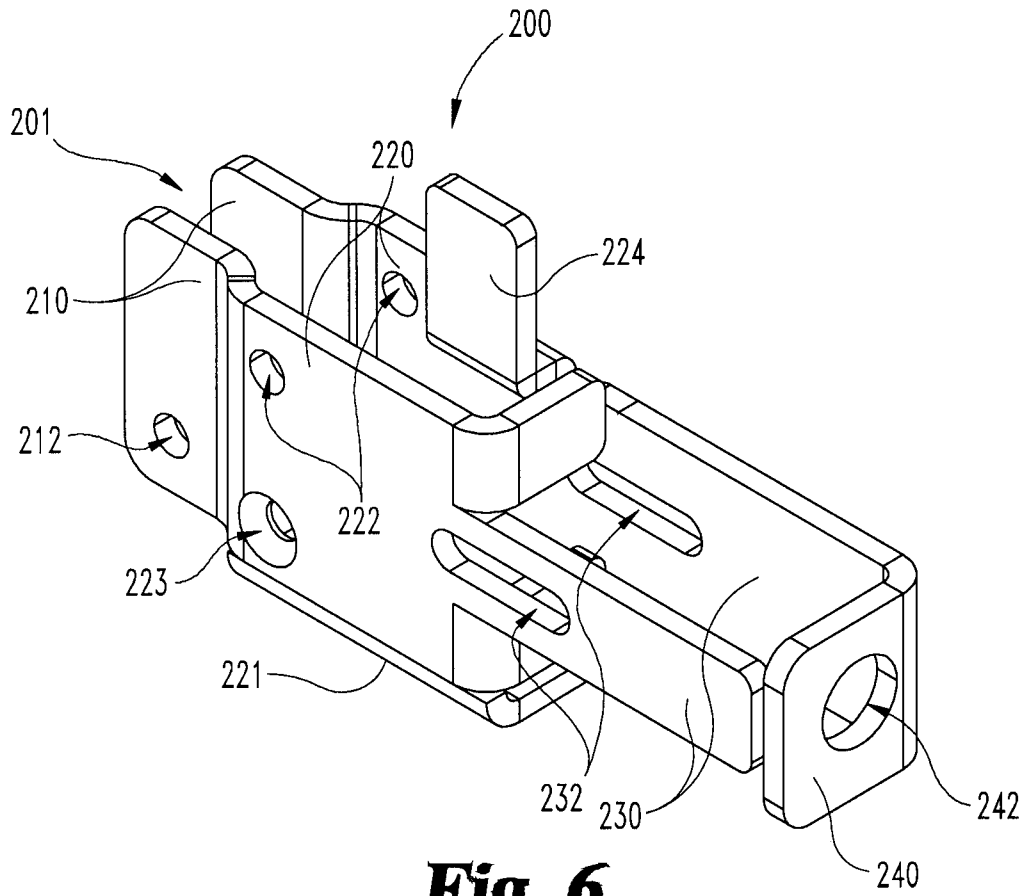


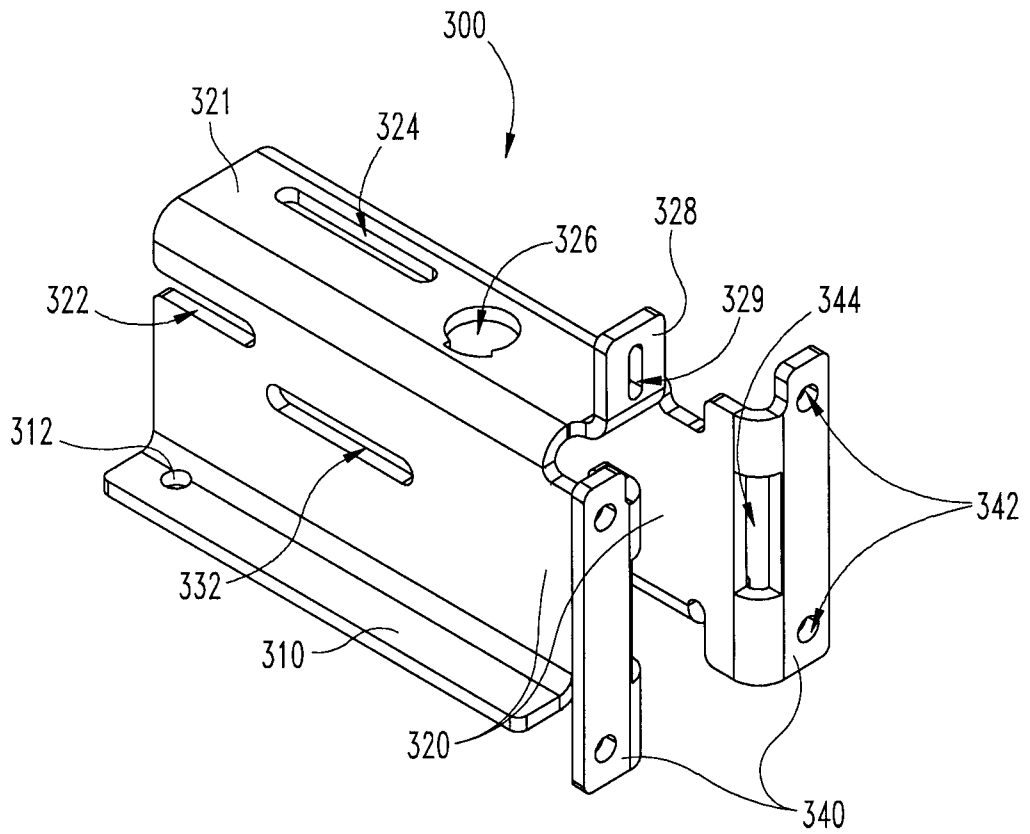
Fig. 4



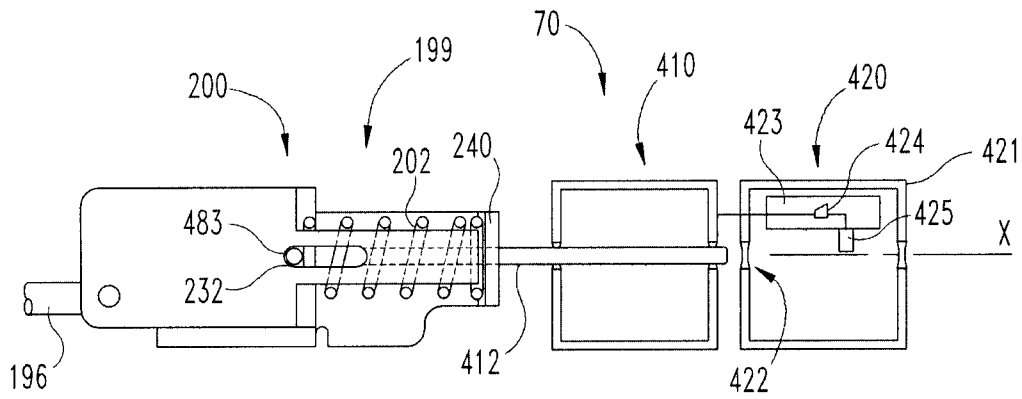
**Fig. 5**



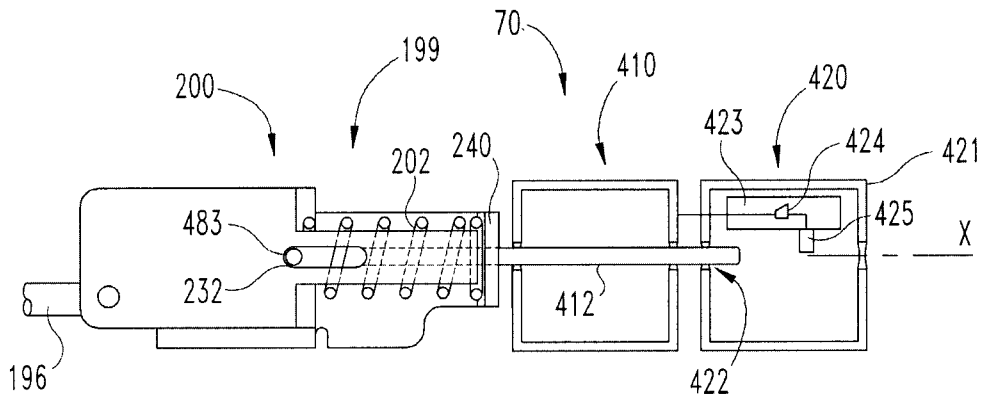
**Fig. 6**



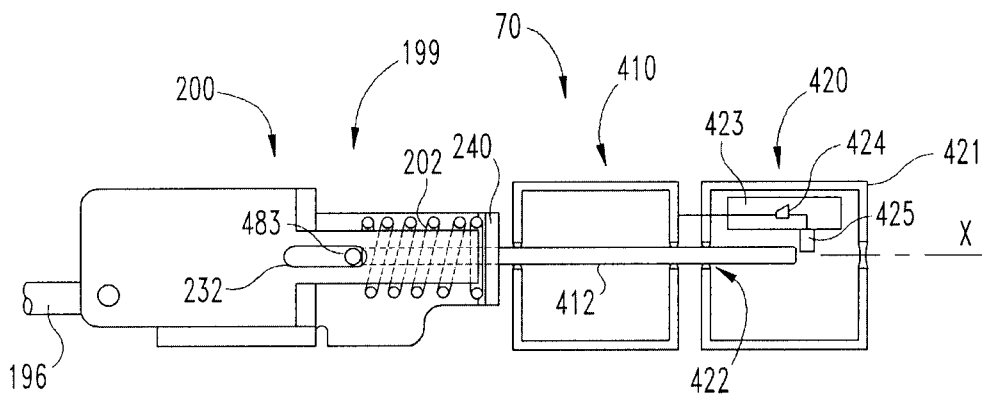
**Fig. 7**



**Fig. 8**

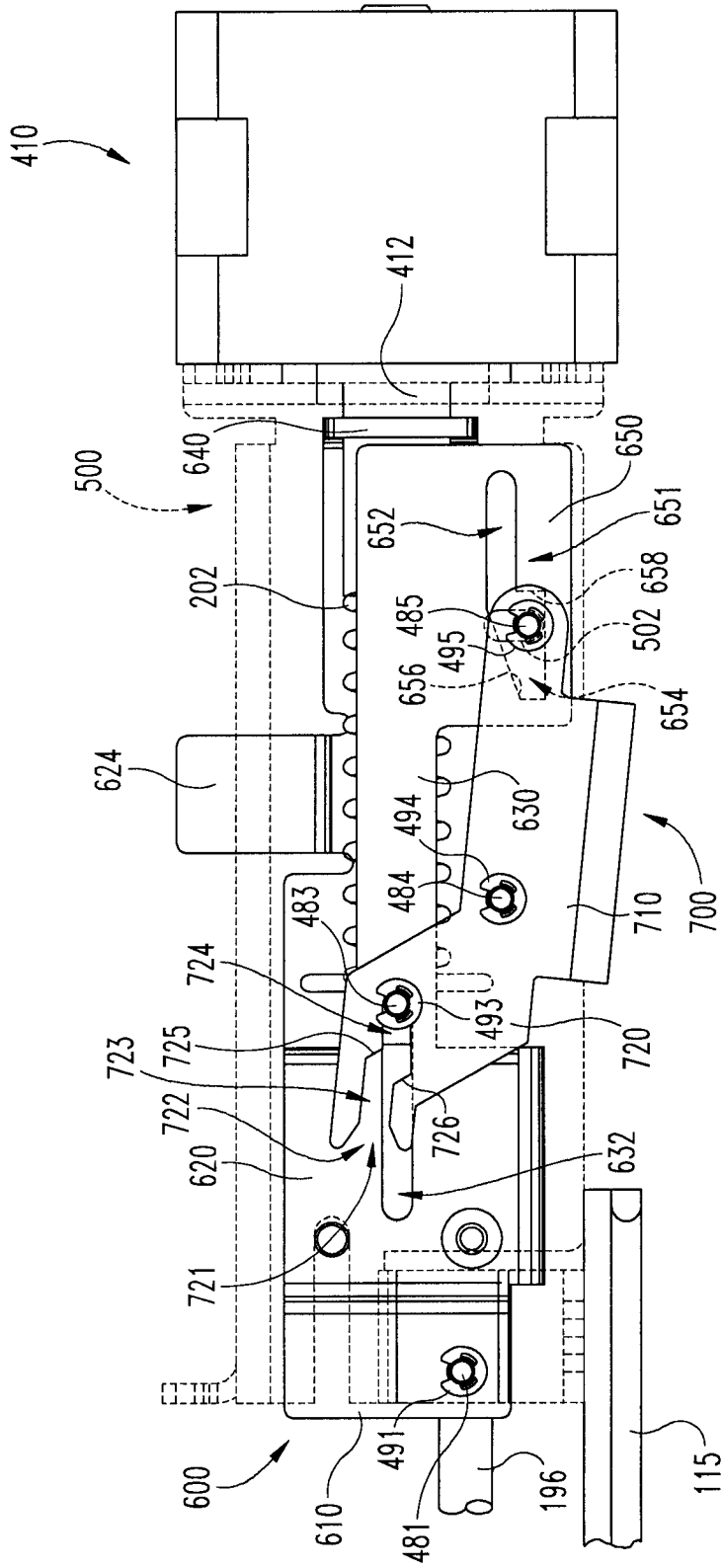


**Fig. 9**



**Fig. 10**





**Fig. 12**

