



- (51) **International Patent Classification:**
A61F 2/44 (2006.01)
- (21) **International Application Number:**
PCT/US2018/029064
- (22) **International Filing Date:**
24 April 2018 (24.04.2018)
- (25) **Filing Language:** English
- (26) **Publication Language:** English
- (30) **Priority Data:**
62/489,080 24 April 2017 (24.04.2017) US
- (71) **Applicant (for all designated States except US):**
UNIVERSITY OF MARYLAND, BALTIMORE
[US/US]; 620 West Lexington Street, 4th Floor, Baltimore,
Maryland 21201 (US).
- (72) **Inventor; and**
(71) **Applicant (for US only): SANSUR, Charles** [US/US]; 613
St. Francis Rd., Towson, Maryland 21286 (US).
- (74) **Agent: JAY, Peter M.;** Wenderoth, Lind & Ponack, L.L.P.,
1030 15th Street NW, STE. 400 E, Washington, District of
Columbia 20005 (US).

- (81) **Designated States (unless otherwise indicated, for every kind of national protection available):** AE, AG, AL, AM, AO, AT, AU, AZ, BA, BB, BG, BH, BN, BR, BW, BY, BZ, CA, CH, CL, CN, CO, CR, CU, CZ, DE, DJ, DK, DM, DO, DZ, EC, EE, EG, ES, FI, GB, GD, GE, GH, GM, GT, HN, HR, HU, ID, IL, IN, IR, IS, JO, JP, KE, KG, KH, KN, KP, KR, KW, KZ, LA, LC, LK, LR, LS, LU, LY, MA, MD, ME, MG, MK, MN, MW, MX, MY, MZ, NA, NG, NI, NO, NZ, OM, PA, PE, PG, PH, PL, PT, QA, RO, RS, RU, RW, SA, SC, SD, SE, SG, SK, SL, SM, ST, SV, SY, TH, TJ, TM, TN, TR, TT, TZ, UA, UG, US, UZ, VC, VN, ZA, ZM, ZW.
- (84) **Designated States (unless otherwise indicated, for every kind of regional protection available):** ARIPO (BW, GH, GM, KE, LR, LS, MW, MZ, NA, RW, SD, SL, ST, SZ, TZ, UG, ZM, ZW), Eurasian (AM, AZ, BY, KG, KZ, RU, TJ, TM), European (AL, AT, BE, BG, CH, CY, CZ, DE, DK, EE, ES, FI, FR, GB, GR, HR, HU, IE, IS, IT, LT, LU, LV, MC, MK, MT, NL, NO, PL, PT, RO, RS, SE, SI, SK, SM, TR), OAPI (BF, BJ, CF, CG, CI, CM, GA, GN, GQ, GW, KM, ML, MR, NE, SN, TD, TG).

Published:
— with international search report (Art. 21(3))

(54) **Title:** CLOWARD-STYLE CERVICAL MESH CAGE WITH LATERAL STABILIZERS

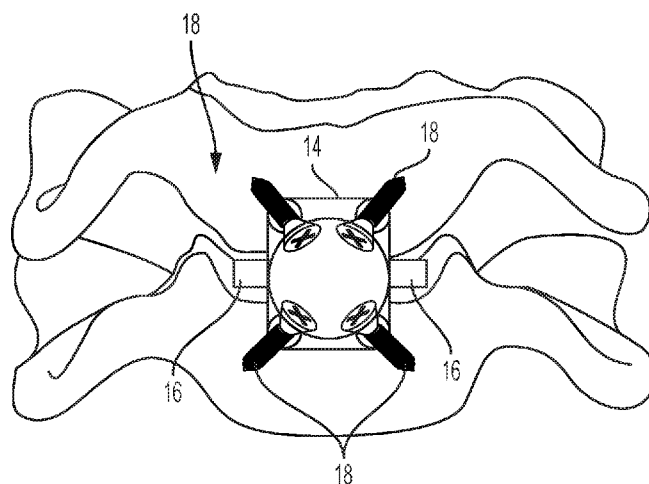

FIG. 4

(57) **Abstract:** A Cloward-style cage device for anterior cervical fusion and fixation includes a body and a lateral stabilizer. The device uses the historical Cloward-style approach, and, as such, decompresses the interbody disc. The device can be used with a cylindrical drill bit to drill through the interbody disc to remove a portion of the interbody endplates to decompress a remaining portion of the interbody disc. The lateral portions of the endplates are generally preserved. The device has a cylindrical body formed of a mesh-like material, with lateral stabilizers.



5

10

TITLE:

CLOWARD-STYLE CERVICAL MESH CAGE WITH LATERAL STABILIZERS

Inventor:

Charles Sansur

15

20

[0001] TECHNICAL FIELD

[0002] The present application relates to Cloward-style cage devices for anterior cervical fusion and fixation that include a body and lateral stabilizers. The devices can be used with a cylindrical drill bit to drill through the interbody disc to remove a portion of the interbody endplates to decompress a remaining portion of the interbody disc and the spinal canal and neural foramen. The lateral portions of the endplates are generally preserved. The device has a cylindrical body formed of a mesh-like material with lateral stabilizers involving the lateral aspect of endplates and uncovertebral joints. In one embodiment, the cage device also includes integrated fixation holes to allow fixation to the vertebral bodies using either screws, pins, or bone anchors. These screws, pins, or anchors would then be secured to the device through locking pins or screws. In an additional embodiment, the cage contains an anterior metal extension that protrudes cephalad and caudal to prevent impaction of cage into spinal canal. One embodiment also uses teeth on the surface of lateral wings to prevent anterior migration of device.

[0003] BACKGROUND

[0004] The current Cloward technique is an anterior cervical discectomy and fusion (“ACDF”) technique that uses a solid cylindrical allograft or auto-graft bone dowel-type graft inserted into a cervical interbody space to increase the interbody height to decompress the spinal cord and nerve roots. The ACDF technique is used to treat spinal cervical abnormalities, such as spondylosis, herniated discs, fractures, and neoplastic lesions. Generally, the technique uses a large drill to remove a volume for bone graft by removing not only the discs, but also the central portion of vertebral endplates to give a better opportunity to decompress neural structures anteriorly.

[0005] However, the current Cloward techniques do not use the remaining portion of the cervical endplate after drilling. Thus, subsidence, which is a decrease of anterior or posterior disc height, is more likely and can cause kyphosis, affect adjacent segment disease, and lower the rate of fusion. Alternative anterior cervical procedures use a standard Smith-Peterson approach, which often leaves residual osteophytes if the endplates are not completely removed. However, subsidence is likely to occur when endplates are completely removed. Furthermore, when

endplates are preserved to reduce the risk of subsidence, there is increased risk of pseudoarthrosis.

[0006] **BRIEF SUMMARY**

[0007] The devices and techniques of the present application give the opportunity to decompress
5 the interbody cervical space by using a modified Cloward-style device. The device substantially
reduces the risk of subsidence compared to typical Cloward-style and other devices. The device
allows for a bone plug or cage insertion and grafting, which reduces the likelihood that the bone
plug will loosen. The Cloward-style device according to one or more embodiments allows the
10 physician to remove substantially all of the desired osteophyte material, and allows the physician
to preserve the partial endplates of the body. The devices further use the preserved lateral
endplates and uncovertebral joint to support and distract the interbody height. Simultaneously, a
cylindrical hole-like defect in the center allows one to remove large osteophytes. At least one
embodiment of the device is configured to stabilize the device translationally and rotationally
15 within the defect. Another embodiment of the device is configured to allow the physician to
secure a lordotic angle, which generally relates to optimizing the curvature of a patient's cervical
spine. Another embodiment of device is configured to comprise a cylindrical mesh like cage that
contains internal lateral interbody wings, where the wings are then deployed laterally through an
expansion mechanism that is controlled from the center of the cylinder.

[0008] A typical Cloward-style technique allows for decompression, even in the setting of large
20 osteophytes, but generally provides unsatisfactory fixation strength. However, the Cloward-style
devices of the present application take advantage of the decompression capabilities of the
established Cloward-style technique and provides a more modern instrumentation solution to
enhance fixation properties, with the opportunity to utilize the remaining lateral endplates to
improve surface area for bone fusion, and reduce subsidence. Thus, the Cloward-style devices of
25 the present application provide an effective solution to at least the above-mentioned problems
with known devices and techniques. Furthermore, by removing the central portion of endplates at
the involved vertebral segment, exposure of the interbody space to the bone marrow of the
vertebral bodies can enhance osseous union and help reduce the incidence of pseudoarthrosis.

[0009] In a first embodiment, the cervical mesh cage device comprises a cylindrical body having a proximal end and a distal end, an endplate fixed to the cylindrical body at the proximal end, wherein the endplate comprises fastener apertures, and a lateral stabilizer. The lateral stabilizer can be a removable wing that removably attaches to the cylindrical body. Further, the lateral stabilizer can be configured to slidably attach to the cylindrical body by sliding axially along a groove on an outer surface of the cylindrical body. The cervical mesh cage device can also include one or more locking mechanisms that secures the lateral stabilizer to the cylindrical body. Also, the cervical mesh cage device can include fasteners that are configured to fix the cervical mesh cage device to a first cervical vertebra and a second cervical vertebra via the fastener apertures. The plurality of fastener apertures of the cervical mesh cage device can be angled divergently from an axis running through the cylindrical body. Further, the cylindrical body can be configured to promote bone growth by providing at least one of a plurality of apertures in the cylindrical body or an outer surface treatment to the cylindrical body.

[0010] A method of inserting the cervical mesh cage device according to the first embodiment comprises drilling a defect in a spine to remove a portion of bone; inserting the cervical mesh cage device into the defect; and fastening the cervical mesh cage device to a first cervical vertebra and a second cervical vertebra in the spine. The method can further comprise placing a bone graft material into the cylindrical body.

[0011] In a second embodiment, the cervical mesh cage device comprises a cylindrical body comprising a top portion and a bottom portion, wherein the cylindrical body has a proximal end and a distal end, an endplate comprising a top endplate and a bottom endplate, wherein the top endplate is fixed to the top portion of the cylindrical body at the proximal end, wherein the bottom endplate is fixed to the bottom portion of the cylindrical body at the proximal end, and wherein the endplate comprises fastener apertures, and lateral stabilizers, wherein the top portion of the cylindrical body and the bottom portion of the cylindrical body are joined by a joint at the distal end of the cylindrical body. The cervical mesh cage device according to the second embodiment, can further comprise a wedge insert. In the cervical mesh cage device according to the second embodiment, the top portion of the cylindrical body and the bottom portion of the cylindrical body can have joint faces that are configured to mate the top portion of the cylindrical

body with the bottom portion of the cylindrical body. Also, the wedge insert can be a pair of strut spacers, and the top portion of the cylindrical body and the bottom portion of the cylindrical body can have joint faces that are configured to mate the top portion of the cylindrical body with a top portion of the strut spacers and the bottom portion of the cylindrical body with a bottom portion of the strut spacers. The cervical mesh cage device according to the second embodiment can further comprise a plurality of fasteners configured to fix the cervical mesh cage device to both a first cervical vertebra and a second cervical vertebra via the fastener apertures. The top portion of the cylindrical body and the bottom portion of the cylindrical body can be joined by the joint to form an angle of between 0 degrees and approximately 25 degrees. The lateral stabilizers can extend from the top portion of the cylindrical body and the bottom portion of the cylindrical body in a direction that is radially outward with respect to a central axis of the cylindrical body. The lateral stabilizers can further extend into the cylindrical body. In cervical mesh cage device according to the second embodiment, the strut spacers can be configured to fix an angle between the top portion of the cylindrical body and the bottom portion of the cylindrical body.

[0012] A method of inserting the cervical mesh cage device according to the second embodiment comprises drilling a defect in a spine to remove a portion of bone; inserting the cervical mesh cage device into the defect; and fastening the cervical mesh cage device to a first cervical vertebra and a second cervical vertebra in the spine. The method can further comprise placing a bone graft material into the cylindrical body.

[0013] In a third embodiment, the cervical mesh cage device comprises a cylindrical body comprising a top portion having a top joint face and a bottom portion having a bottom joint face, wherein the top joint face and the bottom joint face extend in a direction that is radially outward with respect to a central axis of the cylindrical body to form lateral stabilizers, and wherein the top portion of the cylindrical body and the bottom portion of the cylindrical body comprise one or more fixation holes that allow fasteners to be secured from within the cervical mesh cage device. The cervical mesh cage device can further comprise a wedge insert that is a pair of strut spacers, wherein the top portion of the cylindrical body and the bottom portion of the cylindrical

body can be configured to mate the top joint face with a top portion of the strut spacers and the bottom joint face with a bottom portion of the strut spacers

[0014] A method of inserting the cervical mesh cage device according to the third embodiment comprises drilling a defect in a spine to remove a portion of bone; inserting the cervical mesh cage device into the defect; and fastening the cervical mesh cage device to a first cervical vertebra and a second cervical vertebra in the spine.

[0015] In a fourth embodiment, the cervical mesh cage device comprises a cylindrical body having a proximal end and a distal end, an endplate fixed to the cylindrical body at the proximal end, wherein the endplate comprises fastener apertures, and an expandable lateral stabilization mechanism, wherein the expandable lateral stabilization mechanism comprises a cage expansion mechanism and a lateral stabilizer, wherein the cage expansion mechanism is configured to cause the expandable lateral stabilization mechanism to expand in a radial direction from the cylindrical body.

[0016] A method of inserting the cervical mesh cage device according to the fourth embodiment comprises drilling a defect in a spine to remove a portion of bone; inserting the cervical mesh cage device into the defect; expanding the expandable lateral stabilization mechanism; and fastening the cervical mesh cage device to a first cervical vertebra and a second cervical vertebra in the spine. The method can further comprise placing a bone graft material into the cylindrical body.

[0017] Each of the embodiments disclosed herein can be used to treat spinal cervical abnormalities. Thus, the embodiments include the use of the embodiments to treat spinal cervical abnormalities, including, but not limited to, spondylosis, herniated discs, fractures, and neoplastic.

[0018] **BRIEF DESCRIPTION OF THE DRAWINGS**

[0019] The advantages and features of the one or more embodiments of the present application will become more readily apparent by reference to the exemplary, and therefore non-limiting, embodiments illustrated in the drawings.

[0020] **FIG. 1** is an illustration of a standard anterior cervical approach.

[0021] **FIG. 2** is an illustration of interbody discs having a drilled defect.

[0022] **FIG. 3** is an illustration of an embodiment of a Cloward-style cervical mesh cage device inserted in the drilled defect of **FIG. 2**.

5 [0023] **FIG. 4** is an illustration of the embodiment of the Cloward-style cervical mesh cage device of **FIG. 3** inserted in the defect and having fasteners fastened to vertebral bodies.

[0024] **FIG. 5** is an illustration of the embodiment of the Cloward-style cervical mesh cage device of **FIG. 3** inserted in the defect and having fasteners fastened to vertebral bodies and a bone graft material inserted into the cage device.

10 [0025] **FIG. 6** is an illustration of an embodiment of the Cloward-style cervical mesh cage of **FIG. 3** having lateral stabilizers unassembled from the cage device.

[0026] **FIG. 7** is an illustration of an embodiment of the Cloward-style cervical mesh cage of **FIG. 3** with lateral stabilizers assembled from the cage device.

15 [0027] **FIG. 8** is a side view of an embodiment of the Cloward-style cervical mesh cage device of **FIG. 3** having fasteners.

[0028] **FIG. 9** is an illustration of an embodiment of the Cloward-style cervical mesh cage device for lordotic angles inserted in the drilled defect of **FIG. 2**.

[0029] **FIG. 10** is an illustration of the embodiment of the Cloward-style cervical mesh cage device of **FIG. 9** inserted in the defect and having fasteners fastened to vertebral bodies.

20 [0030] **FIG. 11** is an illustration of the embodiment of the Cloward-style cervical mesh cage device of **FIG. 9** inserted in the defect and having fasteners fastened to vertebral bodies and a bone graft material inserted into the cage device.

[0031] **FIG. 12** is side view of the embodiment of the Cloward-style cervical mesh cage device of **FIG. 9** having fasteners.

[0032] **FIG. 13** is front view of the embodiment of the Cloward-style cervical mesh cage device of **FIG. 9**.

[0033] **FIG. 14** is a side view of the embodiment of the Cloward-style cervical mesh cage device of **FIG. 9** without fasteners at a lordotic angle of approximately 0 degrees.

5 [0034] **FIG. 15** is a side view of the embodiment of the Cloward-style cervical mesh cage device of **FIG. 9** with strut spacers at a lordotic angle of approximately 12 degrees.

[0035] **FIG. 16** is front view of the Cloward-style cervical mesh cage device according to another embodiment without an endplate.

10 [0036] **FIG. 17** is a side view of the embodiment of the Cloward-style cervical mesh cage device of **FIG. 16** without an endplate and having fasteners configured to be secured from within the cage device.

[0037] **FIG. 18** an illustration of an embodiment of the Cloward-style cervical mesh cage device having an expandable lateral stabilization mechanism inserted in the drilled defect of **FIG. 2**.

15 [0038] **FIG. 19** is an illustration of the embodiment of the Cloward-style cervical mesh cage device of **FIG. 18** inserted in the defect and having fasteners fastened to vertebral bodies.

[0039] **FIG. 20** is an illustration of the embodiment of the Cloward-style cervical mesh cage device of **FIG. 18** inserted in the defect and having fasteners fastened to vertebral bodies and a bone graft material inserted into the cage device.

20 [0040] **FIG. 21** is an illustration of an embodiment of a cage expansion mechanism the Cloward-style cervical mesh cage device of **FIG. 18** where an expansion screw is being inserted into the cage expansion mechanism.

[0041] **FIG. 22** is a side view of the embodiment of the Cloward-style cervical mesh cage device of **FIG. 18** having fasteners.

[0042] **DETAILED DESCRIPTION**

25 [0043] First Embodiment

[0044] Referring to **FIGS. 2-8**, an embodiment of a Cloward-style cervical mesh cage device **10** or plate cage is configured to reduce compression of a patient's interbody cervical bones, also known as the interbody discs or endplates. **FIG. 2** shows interbody cervical bones, wherein a cylindrical drill bit has removed bone to allow for a satisfactory decompression of midline compression and foraminal disease. The current embodiment of the device **10** is further configured to fit within a defect **D** formed in the patient's interbody cervical bones, as further described below and shown in **FIG. 2**. The device **10** includes a cylindrical body **12**, an endplate **14**, and a lateral stabilizer, and can include fasteners **18**. As seen in **FIG. 3**, for example, the lateral stabilizer can be a pair of lateral stabilizers **16**, where each member of the pair of lateral stabilizers **16** can be located on substantially opposite sides of the body **12**. The body **12** is a generally hollow cylindrical body **12** having a proximal end **20** and a distal end **22**, wherein the endplate **14** is fixed to the cylindrical body **12** at the proximal end **20**. The cylindrical body **12** is configured to frictionally fit within a diameter of the defect **D**. In the current embodiment, the cylindrical body **12** has an outer surface with a diameter that is slightly smaller than the diameter of the defect **D**.

[0045] A physician can advantageously press the cylindrical body **12** within the defect **D** (see **FIGS. 2 and 3**) with only manual force, such as hand force. However, some instances may occur in which friction between the outer surface of the cylindrical body and inner surface of the defect **D** is sufficiently high, such that the physician may require a tool, such as a mallet, to create sufficient force to insert the cylindrical body **12** into the defect **D**. For example, friction between the outer surface of the cylindrical body **12** and inner surface of the defect **D** may be high because at least one of the outer surface of the cylindrical body **12** and the inner surface of the defect **D** has a surface treatment, as further described below, or the diameter of the defect **D** is smaller than the diameter of the cylindrical body **12**.

[0046] As stated above, the cylindrical body **12** is configured to frictionally fit within the defect **D** such that the device **10** may fit stably within the defect **D** over a long period of time. For example, the cylindrical body **12** generally fits within the defect **D** without requiring a physician to readjust the position or orientation of the device **10** caused by substantial loosening of the cylindrical body **12** within the defect **D**.

[0047] In one embodiment, the cylindrical body **12** is configured to promote bone growth of the cervical bones into the outer surface of the device **10** to further fixate the device **10** within the interbody defect **D**. In the current embodiment, the outer surface is configured to promote bone growth, such as by having an outer surface treatment, including a roughened surface, a porous surface, or the like, to generally increase fixation properties and/or surface area of the outer surface. Furthermore, in one embodiment the outer surface treatment may be a coating to promote such bone growth. In another embodiment, the cylindrical body **12** has plurality of apertures from the outer surface to the inner surface, such that the patient's bone can grow through the apertures to a bone graft material **B** that is within the cylindrical body **12**. In yet another embodiment, the cylindrical body **12** includes the plurality of apertures, such as those of a mesh, and the outer surface treatment to promote bone growth.

[0048] The endplate **14** is configured to be adjacent to an anterior face of the cervical bones when the cylindrical body **12** is in the defect **D**, and to allow the bone graft material **B** to be placed within the cylindrical body **12** when the device **10** is in the defect **D**. The endplate **14** of the current embodiment has a generally rectangular-like outer shape with a central aperture and the set of fastener apertures **24**. The central aperture has a diameter that is approximately equal to the inner diameter of the cylindrical body **12**, such that a bone graft material **B** can be placed within the cylindrical body **12** when the device **10** is in the defect **D**. The patient's bone is then able to better fixate to the bone graft material **B** and device **10** to secure the device **10**.

[0049] **FIGS. 4, 5, and 8**, for example, illustrate the set of fastener apertures **24** in which one fastener **18** is located at each corner of the endplate **14**. The set of fastener apertures **24** and endplate **14** may be configured such that fasteners **18** are flush with the endplate **14** when fastened. For example, the set of fastener apertures **24** may be countersunk within the endplate **14** or angled divergently with respect to the axis of the cylindrical body **12**.

[0050] In the current embodiment, the lateral stabilizers **16** are a pair of removable wings **16** (see **FIGS. 6 and 7**). The wings **16** are removable and customizable, such that the physician can customize the size of the wings **16** in accordance with various aspects of the patient, such as the opening/aperture diameter, cervical width, amount of residual compression, interbody opening height, etc. Various height and depth choices are available to accommodate a patient's

individual anatomy. Furthermore, the lateral stabilizers **16** are configured to prevent the device **10** from rotating within the defect **D** and from laterally shifting within the defect **D**. For example, at least a portion of the lateral stabilizers **16** of the current embodiment fit between the interbody bones to prevent rotation of the device **10**. In some embodiments, at least a portion of the lateral stabilizers **16** are in the defect **D**, and in yet another embodiment, at least a portion of the lateral stabilizers **16** are in the defect **D** and are adjacent to bone graft material **B** to promote bone growth. For example, the lateral stabilizers **16** may be configured to promote bone growth by having an outer surface treatment, such as roughened or porous surface, or the like, or a plurality of apertures, such as described above for the outer surface of the cylindrical body **12**.

10 [0051] The lateral stabilizers **16**, such as the pair of removable wings **16**, may be configured to be slidably attached to the cylindrical body **12**. For example, the removable wings **16** may include a dovetail-like joint, such that the removable wings **16** slide axially along a pair of grooves on the outer surface of the cylindrical body **12**.

[0052] The grooves may be configured to prevent the removable wings **16** from moving radially when placed in the grooves. In one embodiment, the device **10** is configured to limit the pair of removable wings **16** from sliding from the proximal end **20** or distal end **22** of the cylindrical body **12**. For example, inner ends of the removable wings **16** that fit within the grooves may be configured to frictionally fit within the groove, such that the inner ends having a ramp-like portion that angles from anterior to posterior ends of the removable wings (e.g., from the proximal end **20** to distal end **22** of the cylindrical body **12**). The ramp-like portion increases the friction between the removable wings **16** and the grooves, thus substantially securing the removable wings **16** to the cylindrical body **12**. Alternatively, the grooves may have a ramp-like portion that angles from proximal end **20** to distal end **22** of the cylindrical body **12**, and the ramp-like portion increases the friction between the removable wings **16** and the groove, thus substantially securing the removable wings **16** to the cylindrical body **12**. As a further alternative, the removable wings **16** may include locking mechanisms, such as fasteners, to secure the removable wings **16** to the cylindrical body **12**.

[0053] The device **10** may be formed of many materials, such as metals, plastics, ceramics, or the like, that are biocompatible and/or approved for medical use. In the current embodiment, the

device **10** is at least partially formed of materials that promotes bone growth and fusion to the device **10**. For example, the device **10** may be formed of a stainless steel alloy, a titanium alloy, polyether ether ketone (PEEK), polyvinyl alcohol (PVA), or the like. Furthermore, the device **10** may be formed of multiple materials, for example, if the cylindrical body **12** is formed of a metal and the endplate **14** is formed of a plastic or a ceramic, or vice versa.

[0054] The device **10** may be manufactured according to common methods, such as additive manufacturing, extruding, injection molding, or the like. In addition, the device **10** can be manufactured by assembling multiple components that may each be manufactured according to common methods, such as those listed above. For example, the endplate **14** may be manufactured separately from a top portion and/or a bottom portion of the cylindrical body **12** and then assembled to form the cylindrical body **12** and the device **10**. The lateral stabilizers **16** may be advantageously manufactured separately from other components to allow the physician to customize many dimensions of the device **10** according to the patient, as discussed above. Further, the surfaces of the lateral stabilizers **16** can be roughened surfaces, such as having teeth, grooves, and the like, to help prevent anterior migration of device **10**. The device **10** can also include an anterior metal extension that protrudes cephalad and caudal to prevent impaction of cage into the spinal canal.

[0055] A method for inserting and using the device **10** includes decompressing the midline of the patient's spine. Compression of the spine is typically caused by midline compression or foraminal disease. In the current embodiment, decompressing the spine includes drilling an aperture or defect **D** in the spine to remove a cylindrical portion of bone, such as by the anterior approach technique. The method includes assembling the device **10**, such as assembling the device **10** according to the desired dimensions for the patient. For example, the device **10** may have particular sizes of the cylindrical body **12**, the endplate **14**, and the lateral stabilizers **16**. The method further includes inserting the device **10** into the defect **D**. In one embodiment, inserting the device **10** includes operating a tool to insert the device **10**, and another embodiment includes inserting the device **10** into the defect **D** using hand force. The method also includes securing the device **10** to the interbody discs. In one embodiment, securing the device **10**

includes fastening fasteners **18** within the apertures **24** of the endplate **14**. Thus, device **10** is inserted into the defect **D**.

[0056] Second Embodiment

[0057] Another embodiment of the Cloward-style mesh cage device **30** is shown in **FIGS. 9-15**.

5 The cage device **30** includes a cylindrical body **32** formed of a top portion **34** and a bottom portion **36**, and an endplate **38**, and can further include a wedge insert **40**. In the current embodiment, the wedge insert **40** can be included and, when included, is a pair of strut spacers, as further described below. Each of the top portion **34** and bottom portion **36** has a clamshell-like shape, such that the top portion **34** and the bottom portion **36** can be joined at a joint face **42** of
10 each top portion **34** and bottom portion **36** to form a cylindrical-like shape, such as described above.

[0058] The endplate **38** is configured to be formed of a top endplate **44** and a bottom endplate **46**, each of which are respectively fixed to the top portion **34** and bottom portion **36** of the cylindrical body **32**. The endplate **38** is configured to be adjacent to an anterior face of the
15 cervical bones when the cylindrical body **32** is in the defect **D**. The endplate **38** also allows the bone graft material **B** to be placed within the cylindrical body **32** when the device **30** is in the defect **D**. Thus, the endplate **38** forms a rectangular-like outer shape having a set of fastener apertures **48** in each corner, similar to the endplate **14** described above that has a generally rectangular-like outer shape with a central aperture and the set of fastener apertures **24**.

20 [0059] For example, **FIGS. 12, 14, and 15** show each of the top portion **34** and the bottom portion **36** of the cylindrical body **32** having a semi-cylindrical-like shape, in which the top portion **34** and the bottom portion **36** have a cross-section that semi-circular-like. In the illustrated embodiment, the top portion **34** and the bottom portion **36** are joined by a joint **50** at the distal end of the cylindrical body **32**. The joint **50** is configured to allow lordotic expansion,
25 as required by the patient's needs. In other words, the cage device **30** has a slit that allows for lordotic expansion when needed. The joint **50** may be a hinge, bendable portion, or the like. Thus, the joint **50** allows the top portion **34** and the bottom portion **36** to form various angles, or lordotic angles, with respect to each other, and as further described below. The lordotic angle of

the illustrated embodiment is approximately between 0 degrees and 12 degrees. For instance, **FIG. 13** shows an embodiment that does not specifically include a wedge insert **40**, and has a lordotic angle of 0 degrees. However, other embodiments have other lordotic angles, such as approximately 15 degrees, 20 degrees, and 25 degrees, etc.

5 [0060] Referring to **FIG. 15**, the joint faces **42** for each top portion **34** and bottom portion **36** of the illustrated embodiment is a face that is substantially flat between the proximal and distal ends of the device **30**, and can mate to the opposite (e.g., top portion **34** or bottom portion **36**) joint face **42** or mate to the pair of strut spacers (wedge insert **40**), as further described below. For example, each of the joint faces **42** may include ridges, teeth, or the like that are configured to
10 position the strut spacers on each of the joint faces **42**.

[0061] Again referring to **FIGS. 9-15**, each of the top portion **34** and bottom portion **36** are configured to provide lateral support for the device **30** by fitting between the interbody discs. In the illustrated embodiment, each of the top portion **34** and the bottom portion **36** provides lateral support using lateral aspects or lateral stabilizers **52** that extend from the joint **50** of each top
15 portion **34** and bottom portion **36** in a direction that is radially outward with respect to a central axis (e.g., extends radially away from and towards the central axis) of the cylindrical body **32** at the joint **50**. Thus, the lateral stabilizers **52** can extend into the cylindrical body and the defect **D**. In another embodiment, the lateral stabilizers **52** extend from the joint **50** of each top portion **34** and bottom portion **36** in a direction that is radially away from the central axis.

20 [0062] The lateral stabilizers **52** are configured to prevent the device **30** from rotating within the defect **D** and from laterally shifting within the defect **D** (see **FIGS. 9-11**). For example, at least a portion of the lateral stabilizers **52** of the current embodiment fit between the interbody bones to prevent rotation of the device **30**. In another embodiment, the lateral stabilizers **52** are removable and can be various sizes, such as described above, to allow a physician to assemble the device **30**
25 having the required size device **30** for the patient's requirements.

[0063] The strut spacers **40** (see **FIG. 15**) are configured to fix the lordotic expansion of the device **30** for the patient. The strut spacers **40** have teeth, ridges, or the like that mate to each of the joint faces **42** of the cylindrical body **32**, such as to the lateral aspects of the lateral stabilizers

52. The strut spacers **40** may mate to each of the joint faces **42** at various positions between the distal end and the proximal end of the cylindrical body **32**. Thus, the strut spacers **40** secure the lordotic angle between the top portion **34** and the bottom portion **36** of the cylindrical body **32** depending on where the strut spacers **40** are fixed along each of the joint faces **42** (e.g., using a trigonometric function). For example, the lordotic angle may be smaller if the strut spacers **40** are fixed near the proximal end of the cylindrical body **32**, as compared to if the strut spacers **40** are fixed near the distal end of the cylindrical body **32**. Further, the surfaces of the lateral stabilizers **52** can be roughened surfaces, such as having teeth, grooves, and the like, to help prevent anterior migration of device **30**. The device **30** can also include an anterior metal extension that protrudes cephalad and caudal to prevent impaction of cage into the spinal canal.

[0064] A method for inserting the cage device **30**, as described above, is similar to the method described above, and includes decompressing the midline of the patient's spine. In the illustrated embodiment shown in **FIGS. 1, 2, and 9-11**, decompressing the spine includes drilling an aperture or defect **D** in the spine to remove a cylindrical portion of bone, such as by the anterior approach technique. The method includes inserting the device **30** into the defect **D**. In one embodiment, inserting a cylindrical body **32** and lateral stabilizers **52** includes operating a tool to insert the device **30**, and another embodiment includes inserting the device **30** into the defect **D** using hand force. The method also includes adjusting a lordotic angle of the device **30**, and securing the lordotic angle of the device **30**. The method further includes positioning a pair of strut spacers **40** in the cylindrical body **32** and lateral stabilizers **52** of the device **30**. The method also includes securing the device **30** to the interbody discs. In one embodiment, securing the device **30** includes fastening fasteners within apertures **48** of the endplate **38**. Thus, device **30** is inserted into the defect **D**.

[0065] The materials and methods of manufacture discussed above can also be applied to the present embodiment.

[0066] Third Embodiment

[0067] Still another embodiment of the Cloward-style mesh cage device **60** is shown in **FIGS. 16 and 17**. The cage device **60** is similar to the cage device **30** of **FIGS. 9-15**, as described

above, including a cylindrical body **62** formed of a top portion **64** and a bottom portion **66**, and can include a pair of strut spacers. However, the cage device **60** is configured to fit entirely within the defect **D**. Thus, the cage device **60** lacks an endplate that is configured to be adjacent to an anterior face of the cervical bones. Each of the top portion **64** and bottom portion **66** has a clamshell-like shape, such that the top portion **64** and the bottom portion **66** can be joined at a joint face **68** of each top portion **64** and bottom portion **66** to form a cylindrical-like shape, such as described above. Thus, the top portion **64** and bottom portion **66** form lateral stabilizers having joint faces, as described above. The lateral stabilizers can be removable or fixed to the cylindrical body **62**. Furthermore, the cylindrical body **62** is configured to be fixed within the defect **D** using fasteners. As such, the cylindrical body **62** can include integrated fixation holes that allow the cage device **60** to be secured to a vertebral body from within the cage device **60**. In the illustrated embodiment of **FIGS. 16** and **17**, the fasteners are pins **70**, although other fasteners may be used, such as screws, bone anchors, or the like. Further, the surfaces of the lateral stabilizers of the present embodiment can be roughened surfaces, such as having teeth, grooves, and the like, to help prevent anterior migration of device **60**. The device **60** can also include an anterior metal extension that protrudes cephalad and caudal to prevent impaction of cage into the spinal canal.

[0068] A method for inserting the cage device **60**, as described above, is similar to the methods described above, and includes decompressing the midline of the patient's spine. As such, decompressing the spine includes drilling an aperture or defect **D** in the spine to remove a cylindrical portion of bone, such as by the anterior approach technique. The method includes inserting the device **60** into the defect **D**. In one embodiment, inserting a cylindrical body **62** includes operating a tool to insert the device **30**, and another embodiment includes inserting the device **60** into the defect **D** using hand force. The method also includes adjusting a lordotic angle of the device **60**, and securing the lordotic angle of the device **60**. The method further includes positioning a pair of strut spacers in the cylindrical body **62** of the device **60**. The method also includes securing the device **60** to the interbody discs. In an embodiment of the method, the top portion **64** and bottom portion **66** can be secured to the interbody discs via the one or more fixation holes.

[0069] The materials and methods of manufacture discussed above can also be applied to the present embodiment.

[0070] Fourth Embodiment

[0071] In a further embodiment, the Cloward-style mesh cage device **80** is shown in **FIGS. 18-22**. As seen in **FIG. 22**, the Cloward-style mesh cage device **80** includes a cylindrical body **82** having a proximal end **83** and a distal end **84**. The cylindrical body **82** can also be configured to promote bone growth by providing a plurality of apertures in the cylindrical body **82**, such as a mesh, or an outer surface treatment to the cylindrical body **82**. The Cloward-style mesh cage device **80** also has an endplate **86** that is fixed to the cylindrical body **82** at a proximal end **83**, and the endplate can contain fastener apertures **88**. The fastener apertures **88** are similar to the fastener apertures discussed in detail above, and can, for example, angled divergently from an axis running through the cylindrical body. Further, as seen in **FIG. 22**, fasteners **89**, such as screws, bone anchors, or the like, can be used to fix the case device **80** to vertebral bodies via the fastener apertures **88**, as discussed and explained above.

[0072] In the present embodiment, the cage device **80** contains an expandable lateral stabilization mechanism **90**. The expandable lateral stabilization mechanism **90** includes a cage expansion mechanism **92** and a lateral stabilizer **94**. The lateral stabilizer **94** can be a pair of wings that are contained within the cylindrical body **82** such that cage device **80** can be inserted into a defect **D**, discussed in detail above, while the lateral stabilizer **94** is contained within the cylindrical body **82**. To allow the lateral stabilizer **94** to be contained in the cylindrical body **82**, the lateral stabilizer **94** can be angled internally. For instance, when the cylindrical body **82** is a pair of wings, each of the wings of the pair of wings can be angled such that both wings fit within the cylindrical body **82**.

[0073] The cage expansion mechanism **92** can cause the expandable lateral stabilization mechanism to expand in a radial direction from the cylindrical body **82**, as seen in **FIG. 19**. In an embodiment, the cage expansion mechanism **92** includes an expansion screw **96** and angled inner walls **98**. The angled inner walls **98** can be part of or fixed to the lateral stabilizer **94**. As the expansion screw **96** is inserted or screwed into the cage expansion mechanism **92**, outward

force from the expansion of the cage expansion mechanism **92** causes the lateral stabilizer **94** to expand out of the cylindrical body **82** in a radial direction. Further, the cage expansion mechanism **92** can include a receiving portion **99** configured to receive the expansion screw **96** by, for example, having threads configured to mate with the threads of the expansion screw **96**.

5 The cage expansion mechanism **92** can be fixed to the distal end **84** of the cylindrical body **82** and/or the inner surface of the cylindrical body **82**. When the expansion screw **96** is fully inserted into the case expansion mechanism **92** (i.e., the expansion screw **96** is fully tightened), the lateral stabilizer **94** is fully deployed such that the lateral stabilizer **94** extends from the cylindrical body **82** in a radial direction, and also can lock the cage expansion mechanism **92** in

10 place. Further, the surfaces of the lateral stabilizer **94** can be roughened surfaces, such as having teeth, grooves, and the like, to help prevent anterior migration of device **80**. The device **80** can also include an anterior metal extension that protrudes cephalad and caudal to prevent impaction of cage into the spinal canal.

[0074] A method for inserting the cage device **80**, as described above, is similar to the methods

15 described above, and includes decompressing the midline of the patient's spine. Decompressing the spine includes drilling an aperture or defect **D** in the spine to remove a cylindrical portion of bone, such as by the anterior approach technique. The method includes inserting the device **60** into the defect **D**. In one embodiment, inserting a cylindrical body **82** includes operating a tool to insert the device **80**, and another embodiment includes inserting the device **80** into the defect **D**

20 using hand force. The method also includes the expansion of the cage expansion mechanism **92** to deploy the lateral stabilizer **94** from the cylindrical body **82**, and can be done via hand force or using a tool, such as a manual, pneumatic, or electric screwdriver, hex key, and the like. The method also includes securing the device **80** to the interbody discs with the fasteners **89**, as discussed above. The device **80** can be secured before, during, or after the expansion of the cage

25 expansion mechanism **92** to deploy the lateral stabilizer **94** from the cylindrical body **82**. Bone graft material **B** can be placed in the cylindrical body **82**. As discussed above, a bone graft, such as the bone graft material **B**, can assist with the fixation of the cage device **80** to the interbody discs from within the defect **D**. The cylindrical body **82**, therefore, can include a plurality of apertures, such as those of a mesh, and can also include an outer surface treatment to promote

30 bone growth.

[0075] The materials and methods of manufacture discussed above can also be applied to the present embodiment.

CLAIMS

1. A cervical mesh cage device comprising
a cylindrical body having a proximal end and a distal end,
an endplate fixed to the cylindrical body at the proximal end, wherein the endplate
5 comprises fastener apertures, and
a lateral stabilizer.
2. The cervical mesh cage device according to claim 1, wherein the lateral stabilizer is a
removable wing that removably attaches to the cylindrical body.
- 10 3. The cervical mesh cage device according to claim 1, wherein the lateral stabilizer is
configured to slidably attach to the cylindrical body by sliding axially along a groove on an outer
surface of the cylindrical body.
- 15 4. The cervical mesh cage device according to claim 1, wherein the cervical mesh cage
device further comprises one or more locking mechanisms that secures the lateral stabilizer to the
cylindrical body.
- 20 5. The cervical mesh cage device according to claim 1, further comprising fasteners that are
configured to fix the cervical mesh cage device to a first cervical vertebra and a second cervical
vertebra via the fastener apertures.
- 25 6. The cervical mesh cage device according to claim 1, wherein the plurality of fastener
apertures are angled divergently from an axis running through the cylindrical body.
7. The cervical mesh cage device according to claim 1, wherein the cylindrical body is
configured to promote bone growth by providing at least one of a plurality of apertures in the
cylindrical body or an outer surface treatment to the cylindrical body.
- 30 8. A method of inserting the cervical mesh cage device according to claim 1 comprising

drilling a defect in a spine to remove a portion of bone;
inserting the cervical mesh cage device into the defect; and
fastening the cervical mesh cage device to a first cervical vertebra and a second cervical vertebra in the spine.

5

9. The method according to claim 8, further comprising placing a bone graft material into the cylindrical body.

10. A cervical mesh cage device comprising

10 a cylindrical body comprising a top portion and a bottom portion, wherein the cylindrical body has a proximal end and a distal end,

an endplate comprising a top endplate and a bottom endplate,

wherein the top endplate is fixed to the top portion of the cylindrical body at the proximal end,

15 wherein the bottom endplate is fixed to the bottom portion of the cylindrical body at the proximal end, and

wherein the endplate comprises fastener apertures, and
a lateral stabilizer,

20 wherein the top portion of the cylindrical body and the bottom portion of the cylindrical body are joined by a joint at the distal end of the cylindrical body.

11. The cervical mesh cage device according to claim 10, further comprising a wedge insert.

25 12. The cervical mesh cage device according to claim 10, wherein the top portion of the cylindrical body and the bottom portion of the cylindrical body have joint faces that are configured to mate the top portion of the cylindrical body with the bottom portion of the cylindrical body.

30 13. The cervical mesh cage device according to claim 11, wherein the wedge insert is a pair of strut spacers, and wherein the top portion of the cylindrical body and the bottom portion of the

cylindrical body have joint faces that are configured to mate the top portion of the cylindrical body with a top portion of the strut spacers and the bottom portion of the cylindrical body with a bottom portion of the strut spacers.

5 14. The cervical mesh cage device according to claim 10, further comprising a plurality of fasteners configured to fix the cervical mesh cage device to both a first cervical vertebra and a second cervical vertebra via the fastener apertures.

10 15. The cervical mesh cage device according to claim 14, wherein the top portion of the cylindrical body and the bottom portion of the cylindrical body are joined by the joint to form an angle of between 0 degrees and approximately 25 degrees.

15 16. The cervical mesh cage device according to claim 11, wherein the lateral stabilizer extends from the top portion of the cylindrical body and the bottom portion of the cylindrical body in a direction that is radially outward with respect to a central axis of the cylindrical body.

17. The cervical mesh cage device according to claim 16, wherein the lateral stabilizer further extends into the cylindrical body.

20 18. The cervical mesh cage device according to claim 13, wherein the strut spacers are configured to fix an angle between the top portion of the cylindrical body and the bottom portion of the cylindrical body.

25 19. A method of inserting the cervical mesh cage device according to claim 10 comprising drilling a defect in a spine to remove a portion of bone;
inserting the cervical mesh cage device into the defect; and
fastening the cervical mesh cage device to a first cervical vertebra and a second cervical vertebra in the spine.

20. The method according to claim 19, further comprising placing a bone graft material into the cylindrical body.

21. A cervical mesh cage device comprising

5 a cylindrical body comprising a top portion having a top joint face and a bottom portion having a bottom joint face, wherein the top joint face and the bottom joint face extend in a direction that is radially outward with respect to a central axis of the cylindrical body to form a lateral stabilizer, and

10 wherein the top portion of the cylindrical body and the bottom portion of the cylindrical body comprise one or more fixation holes that allow fasteners to be secured from within the cervical mesh cage device.

22. The cervical mesh cage device according to claim 21, further comprising a wedge insert that is a pair of strut spacers, wherein the top portion of the cylindrical body and the bottom
15 portion of the cylindrical body are configured to mate the top joint face with a top portion of the strut spacers and the bottom joint face with a bottom portion of the strut spacers.

23. A method of inserting the cervical mesh cage device according to claim 21 comprising
20 drilling a defect in a spine to remove a portion of bone;

inserting the cervical mesh cage device into the defect; and

fastening the cervical mesh cage device to a first cervical vertebra and a second cervical
vertebra in the spine.

24. A cervical mesh cage device comprising

25 a cylindrical body having a proximal end and a distal end,

an endplate fixed to the cylindrical body at the proximal end, wherein the endplate
comprises fastener apertures, and

an expandable lateral stabilization mechanism,

30 wherein the expandable lateral stabilization mechanism comprises a cage expansion
mechanism and a lateral stabilizer,

wherein the cage expansion mechanism is configured to cause the expandable lateral stabilization mechanism to expand in a radial direction from the cylindrical body.

25. A method of inserting the cervical mesh cage device according to claim 24 comprising
- 5 drilling a defect in a spine to remove a portion of bone;
inserting the cervical mesh cage device into the defect;
expanding the expandable lateral stabilization mechanism; and
fastening the cervical mesh cage device to a first cervical vertebra and a second cervical
- 10 vertebra in the spine.

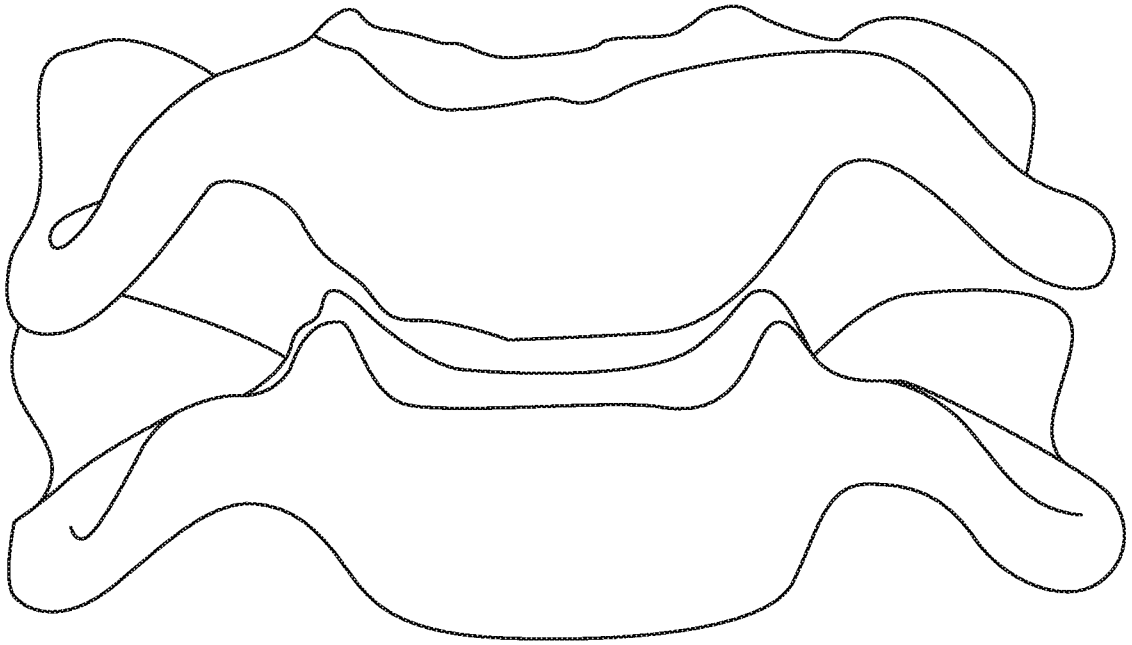

FIG. 1

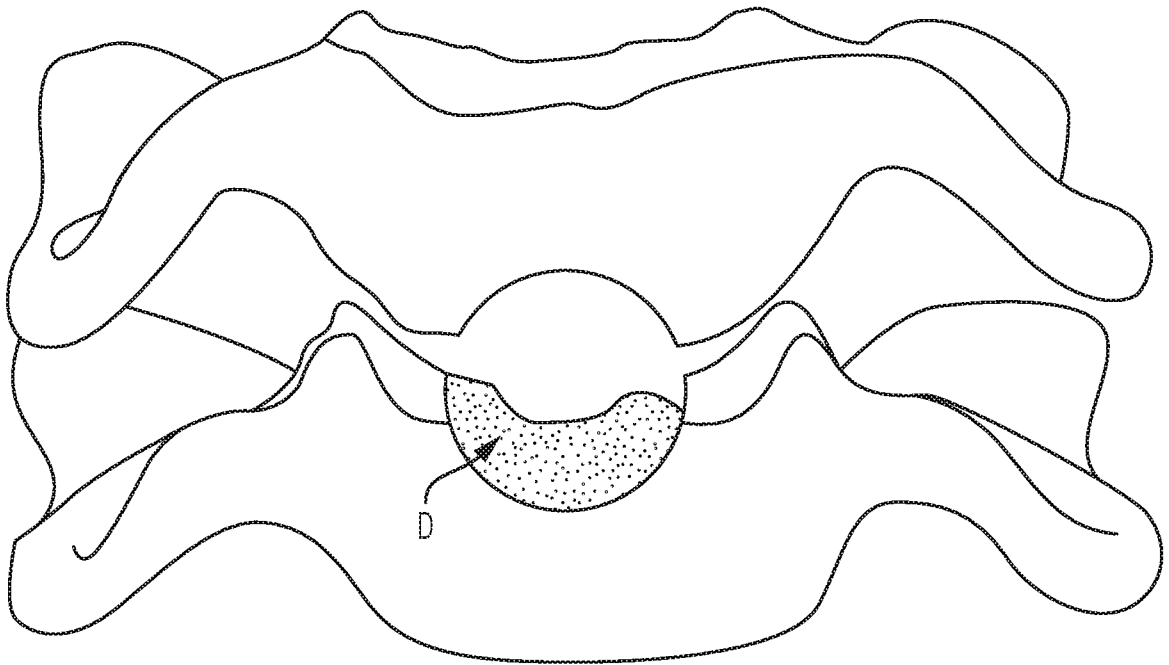

FIG. 2

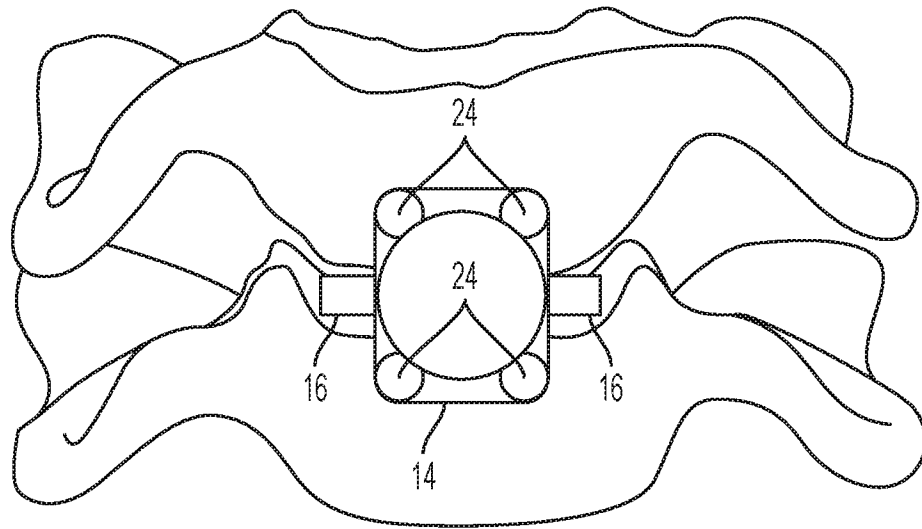

FIG. 3

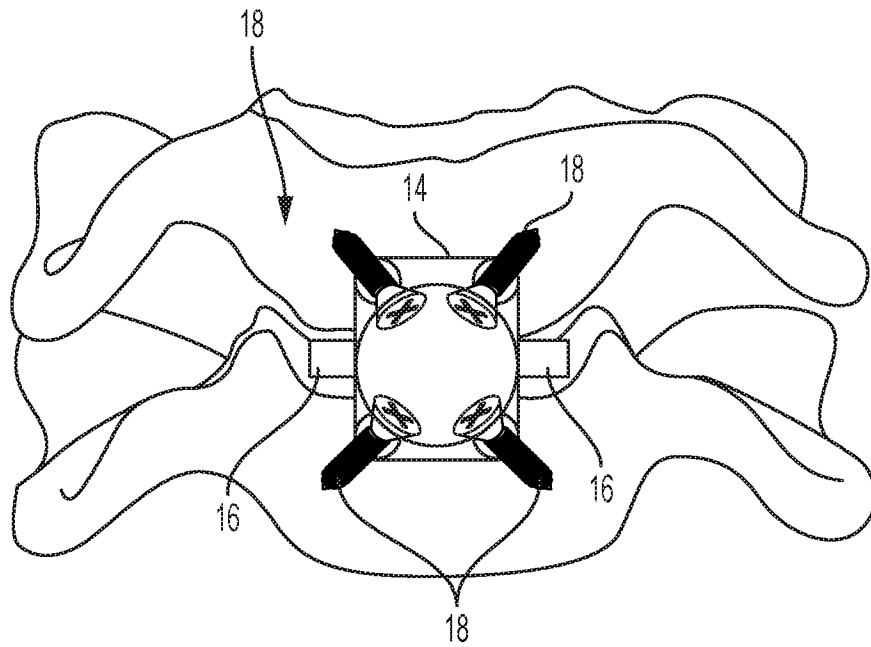

FIG. 4

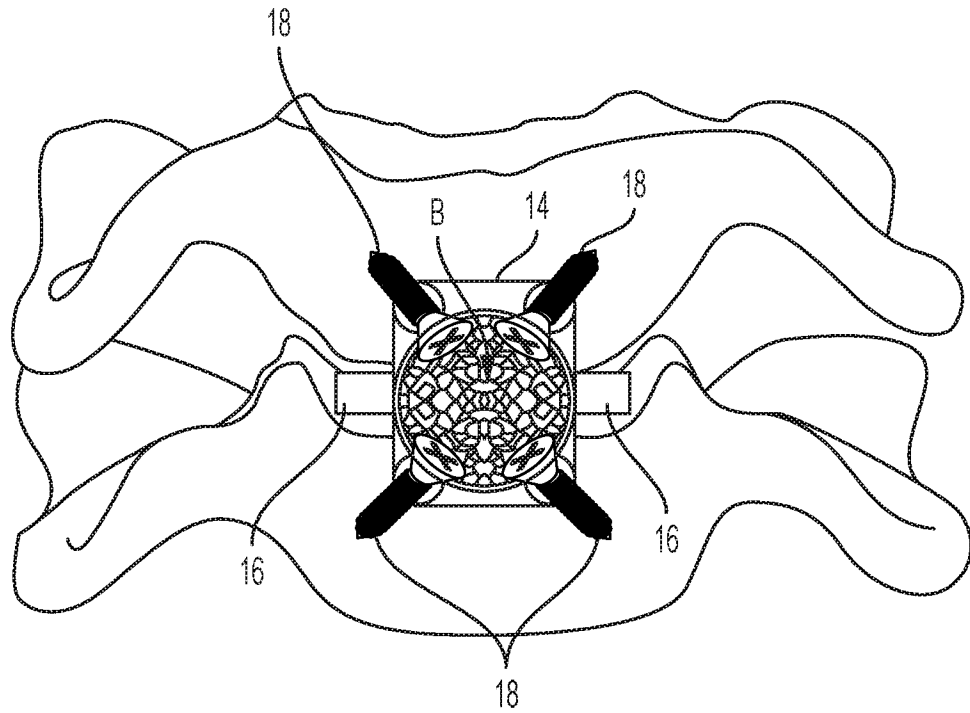

FIG. 5

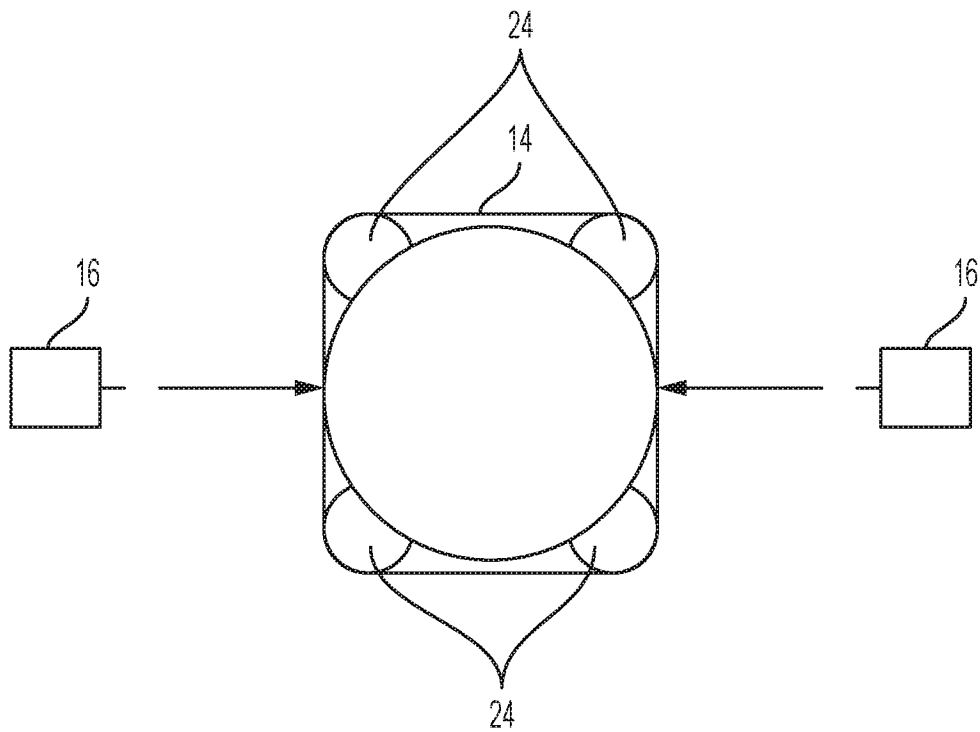

FIG. 6

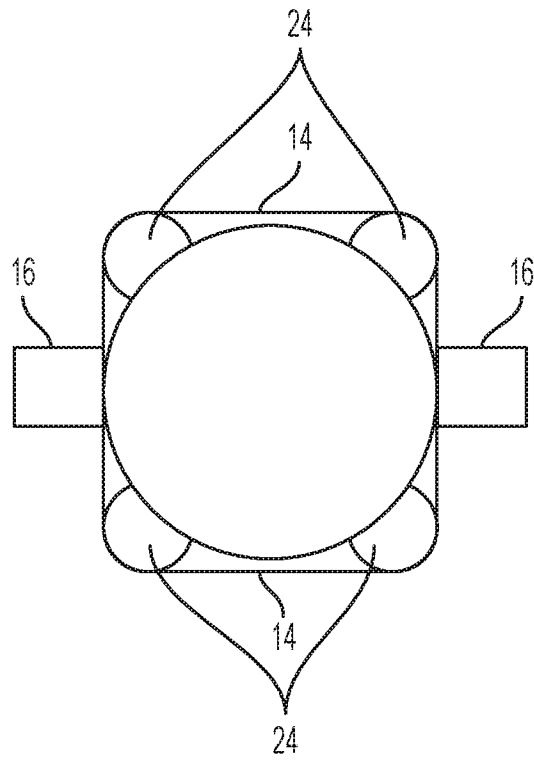

FIG. 7

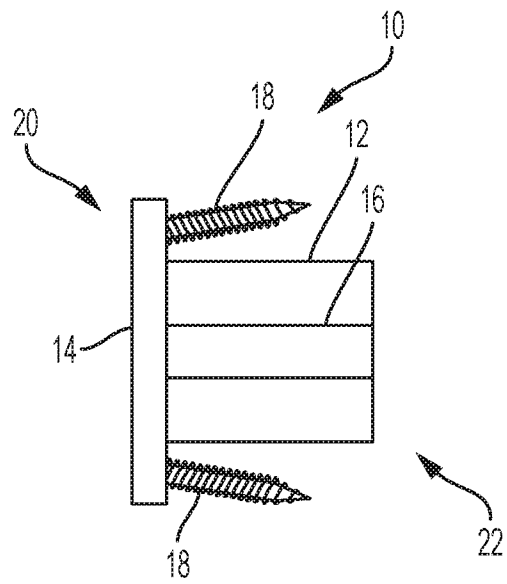

FIG. 8

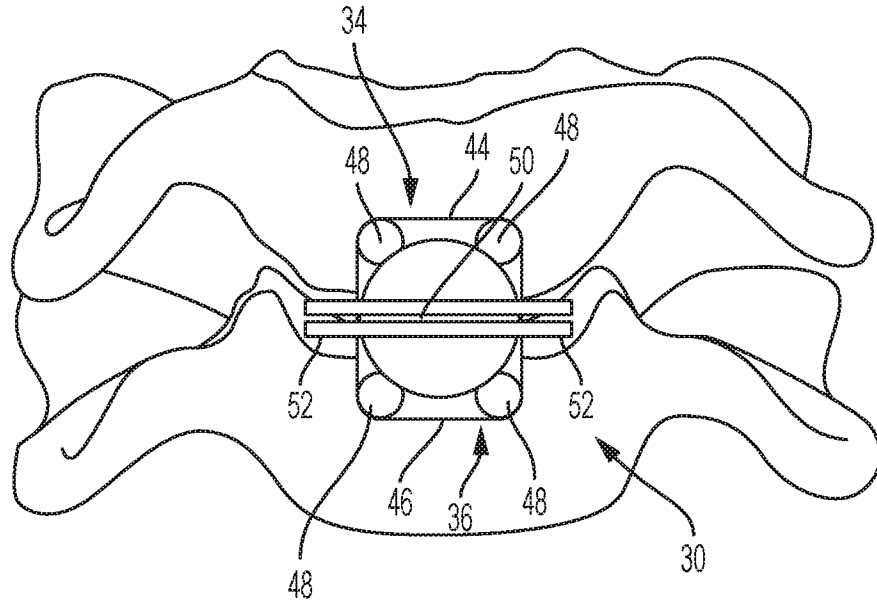

FIG. 9

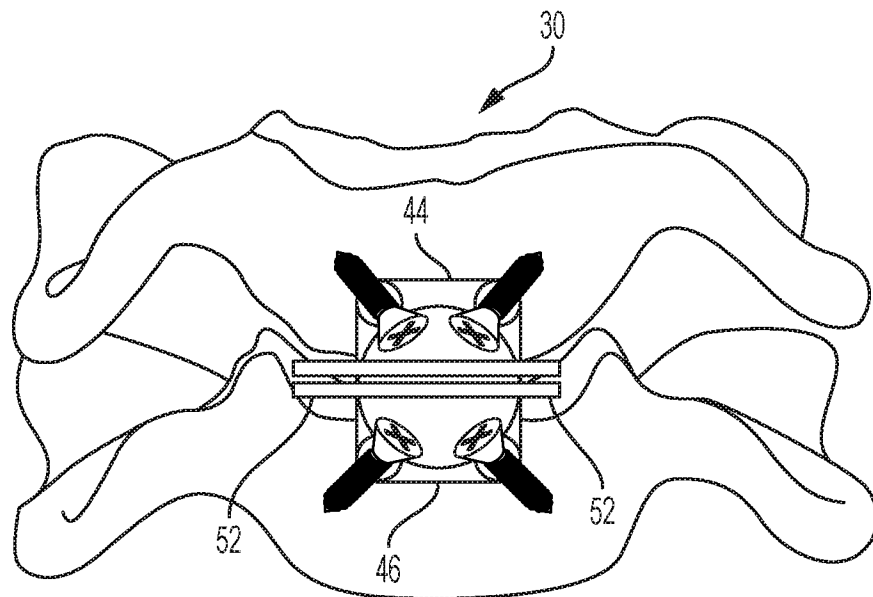

FIG. 10

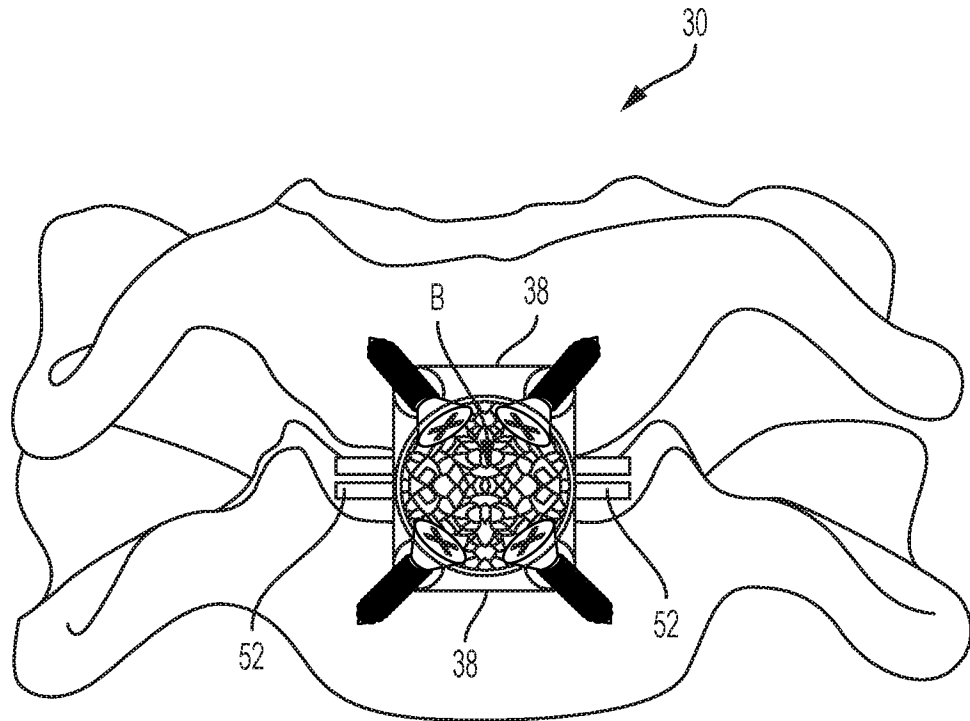

FIG. 11

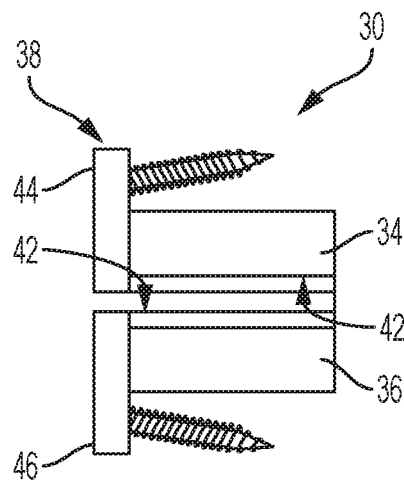

FIG. 12

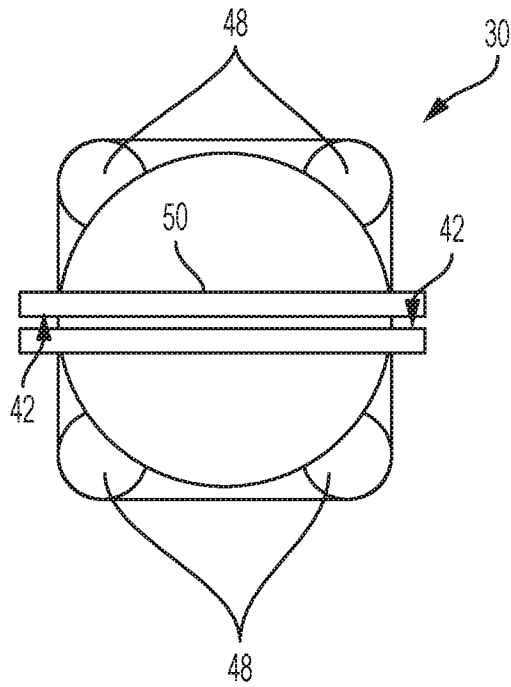

FIG. 13

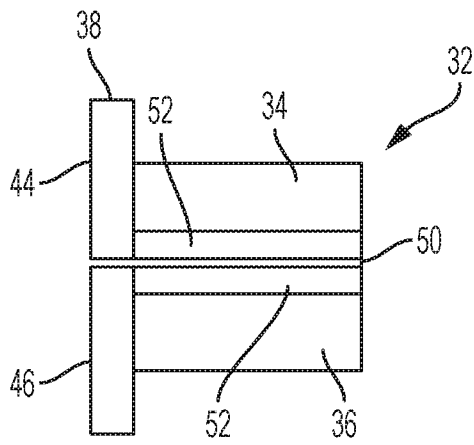

FIG. 14

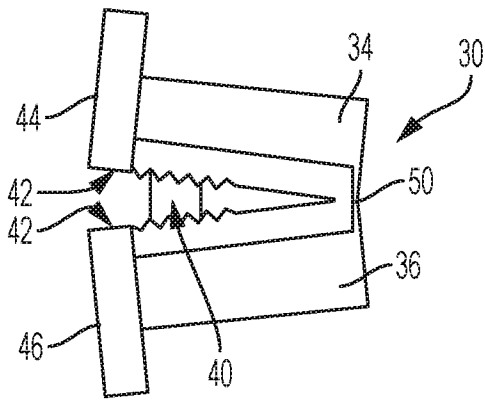

FIG. 15

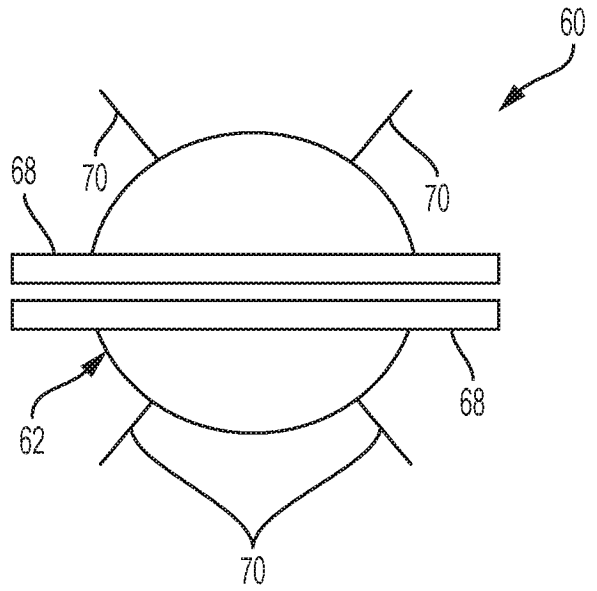

FIG. 16

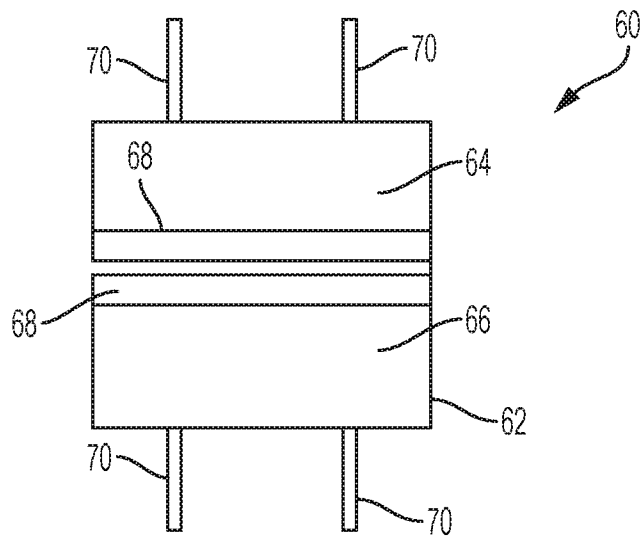

FIG. 17

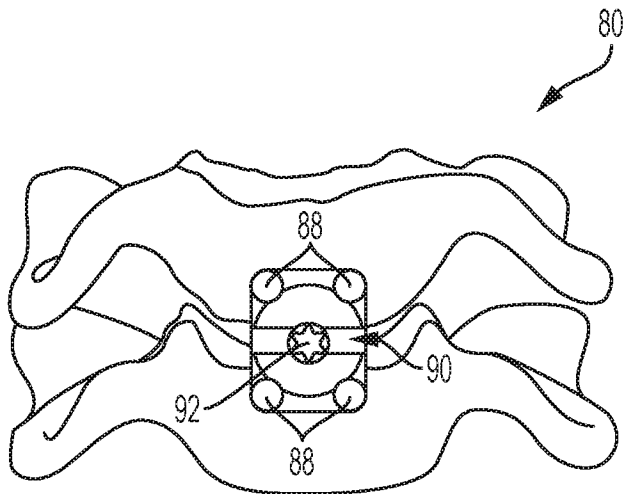

FIG. 18

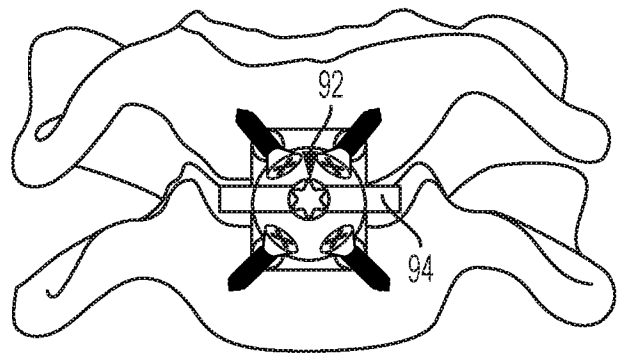

FIG. 19

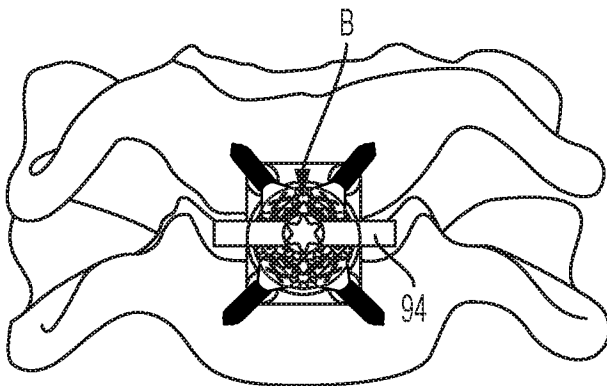

FIG. 20

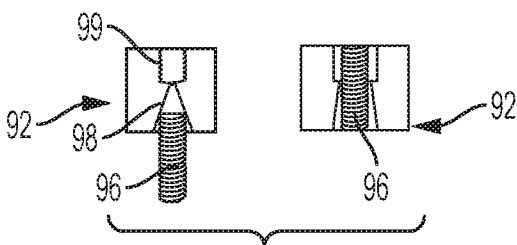

FIG. 21

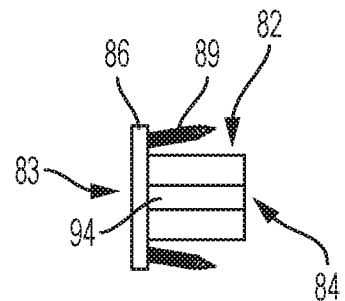

FIG. 22

INTERNATIONAL SEARCH REPORT

International application No.

PCT/US 18/29064

A. CLASSIFICATION OF SUBJECT MATTER

IPC(8) - A61F 2/44 (2018.01)
 CPC - A61F 2/44, 2/446, 2/4465

According to International Patent Classification (IPC) or to both national classification and IPC

B. FIELDS SEARCHED

Minimum documentation searched (classification system followed by classification symbols)

See Search History Document

Documentation searched other than minimum documentation to the extent that such documents are included in the fields searched

See Search History Document

Electronic data base consulted during the international search (name of data base and, where practicable, search terms used)

See Search History Document

C. DOCUMENTS CONSIDERED TO BE RELEVANT

Category*	Citation of document, with indication, where appropriate, of the relevant passages	Relevant to claim No.
X --- Y --- A	US 2001/0020185 A1 (RAY) 6 September 2001 (06.09.2001) see especially para [0005], [0018], [0021], [0023], [0026], [0027], fig 1-5	1-2, 4-5, 7-9 ----- ----- 3, 6 ----- 10-25
Y	US 8,932,358 B1 (NEHLS) 13 January 2015 (13.01.2015) see especially col 7, ln 59 to col 8, ln 37, col 8, ln 54 to col 9, ln 2, col 10, ln 17-55, fig 2A-B, 3A-B, 4A-D, 6	3, 6
A	US 2003/0149484 A1 (MICHELSON) 7 August 2003 (07.08.2003) see especially para [0076], [0101], [0116]-[0119], fig 1-7, 17-19	10-23
A	US 2003/0204261 A1 (EISERMANN et al) 30 October 2003 (30.10.2003) see especially para [0035], [0036], [0041], [0042], fig 1-4, 6-8	10-23
A	US 2006/0167547 A1 (SUDDABY) 27 July 2006 (27.07.2006) see especially para [0026], [0027], [0031], fig 1-5	24-25
A	US 6,332,895 B1 (SUDDABY) 25 December 2001 (25.12.2001) see especially col 4, ln 18-34, col 5, ln 14-25, fig 1-5, 7	24-25
A	US 2012/0065688 A1 (NEHLS) 15 March 2012 (15.03.2012) see whole document	1-25
A	US 2010/0286785 A1 (GRAYSON) 11 November 2010 (11.11.2010) see whole document	1-25

Further documents are listed in the continuation of Box C.

See patent family annex.

* Special categories of cited documents:

"A" document defining the general state of the art which is not considered to be of particular relevance

"E" earlier application or patent but published on or after the international filing date

"L" document which may throw doubts on priority claim(s) or which is cited to establish the publication date of another citation or other special reason (as specified)

"O" document referring to an oral disclosure, use, exhibition or other means

"P" document published prior to the international filing date but later than the priority date claimed

"T" later document published after the international filing date or priority date and not in conflict with the application but cited to understand the principle or theory underlying the invention

"X" document of particular relevance; the claimed invention cannot be considered novel or cannot be considered to involve an inventive step when the document is taken alone

"Y" document of particular relevance; the claimed invention cannot be considered to involve an inventive step when the document is combined with one or more other such documents, such combination being obvious to a person skilled in the art

"&" document member of the same patent family

Date of the actual completion of the international search

26 June 2018

Date of mailing of the international search report

20 JUL 2018

Name and mailing address of the ISA/US

Mail Stop PCT, Attn: ISA/US, Commissioner for Patents
 P.O. Box 1450, Alexandria, Virginia 22313-1450
 Facsimile No. 571-273-8300

Authorized officer:

Lee W. Young

PCT Helpdesk: 571-272-4300
 PCT OSP: 571-272-7774

INTERNATIONAL SEARCH REPORT

International application No.

PCT/US 18/29064

C (Continuation). DOCUMENTS CONSIDERED TO BE RELEVANT		
Category*	Citation of document, with indication, where appropriate, of the relevant passages	Relevant to claim No.
A	US 2008/0188941 A1 (GROTZ) 7 August 2008 (07.08.2008) see whole document	1-25
A	US 6,582,431 B1 (RAY) 24 June 2003 (24.06.2003) see whole document	1-25
A	US 6,371,987 B1 (WEILAND et al) 16 April 2002 (16.04.2002) see whole document	1-25
A	US 5,683,394 A (RINNER) 4 November 1997 (04.11.1997) see whole document	1-25
A	WO 1997/23174 A1 (COLORADO) 3 July 1997 (03.07.1997) see whole document and machine translation	1-25