

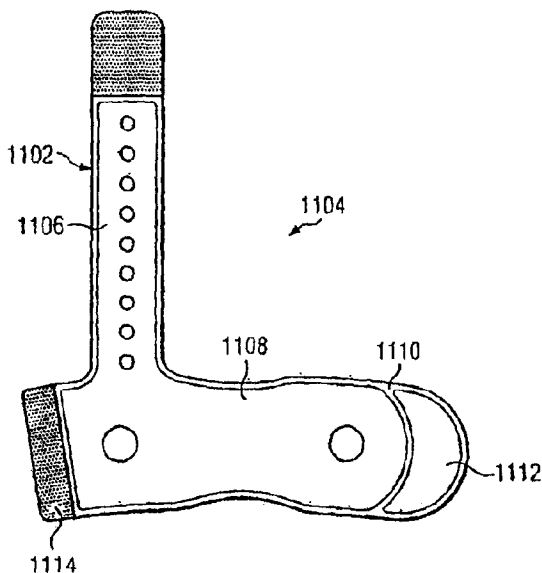

(22) Date de dépôt/Filing Date: 2007/04/11  
 (41) Mise à la disp. pub./Open to Public Insp.: 2007/10/25  
 (45) Date de délivrance/Issue Date: 2022/01/04  
 (62) Demande originale/Original Application: 2 982 029  
 (30) Priorités/Priorities: 2006/04/11 (US60/791,132);  
 2006/06/30 (US60/817,932); 2007/04/10 (US11/733,709)

(51) Cl.Int./Int.Cl. *A61F 7/00* (2006.01),  
*A61F 5/34* (2006.01), *A61F 7/02* (2006.01),  
*A61F 7/08* (2006.01), *A61H 9/00* (2006.01)  
 (72) Inventeurs/Inventors:  
 PARISH, OVERTON L., US;  
 BALACHANDRAN, NIRAN, US;  
 QUISENBERRY, TONY, US  
 (73) Propriétaire/Owner:  
 THERMOTEK, INC., US  
 (74) Agent: RIDOUT & MAYBEE LLP

(54) Titre : SYSTEME DE THERAPIE DVT POUR LE CHAUFFAGE OU LE REFROIDISSEMENT D'UN LIQUIDE CALOPORTEUR  
 (54) Title: DVT THERAPY SYSTEM FOR HEATING OR COOLING A HEAT-TRANSFER LIQUID



(57) **Abrégé/Abstract:**

A DVT and temperature therapy system. A temperature therapy blanket includes a fluid bladder for delivering hot and/or cold therapy to a patient. The temperature therapy blanket may also include an air bladder for providing compression. The DVT system functions independently of the temperature therapy. This Abstract is provided to comply with rules requiring an Abstract that allows a searcher or other reader to quickly ascertain subject matter of the technical disclosure. This Abstract is submitted with the understanding that it will not be used to interpret or limit the scope or meaning of the claims.

## ABSTRACT

A DVT and temperature therapy system. A temperature therapy blanket includes a fluid bladder for delivering hot and/or cold therapy to a patient. The temperature therapy blanket may also include an air bladder for providing compression. The DVT system functions independently of the temperature therapy. This Abstract is provided to comply with rules requiring an Abstract that allows a searcher or other reader to quickly ascertain subject matter of the technical disclosure. This Abstract is submitted with the understanding that it will not be used to interpret or limit the scope or meaning of the claims.

## **DVT THERAPY SYSTEM FOR HEATING OR COOLING A HEAT-TRANSFER LIQUID**

[001] This application is a divisional of Canadian Application No. 2982029, which in turn is a divisional of Canadian Application No. 2649167 filed on April 11, 2007.

### **BACKGROUND OF THE INVENTION**

#### Technical Field

[002] The present invention relates to medical therapy systems in general, including therapeutic cooling, heating, and compression systems used in association therewith, and more particularly, but not by way of limitation, to a programmable, thermal therapy and external pneumatic compression for the prevention of deep vein thrombosis.

#### Description of the Related Art

[003] Considerable medical attention has been given to the serious medical issue of Deep Vein Thrombosis (“DVT”). One approach to the prevention of DVT has been External Pneumatic Compressions (“EPC”). EPC has been shown to be helpful as a prophylaxis for DVT, although refinements over existing systems are still in need. For example, multiple articles have been written addressing this issue, including a compilation of recommendations for preventing DVT (Heit JA: Current Recommendations for Prevention of Deep Venous Thrombosis. In: *Handbook of Venous Disorders*. Gloviczki P, Yao JS, eds. Cambridge, The University Press, 1996). Engineering studies are presented which also address EPC as a preventative for DVT (Kamm RD: Bioengineering Studies of Periodic External Compression as Prophylaxis Against Deep Vein Thrombosis - Part 1: Numerical Studies. *J Biomech*

*Engineering* 104(1): 87-95, 1982). Such efforts are meritorious for patient health due to possible Pulmonary Embolism (“PE”) resulting from DVT (National Institutes of Health Consensus Development Conference Statement: Prevention of Venous Thrombosis and Pulmonary Embolism. *JAMA* 6(2) 744-749, 1986). Additionally, studies have been performed relative to DVT and orthopedic surgery (“OS”) (Westrich GH, Sculco TP: Prophylaxis Against Deep Vein Thrombosis After Total Knee Arthroplasty. *J Bone Joint Surg* 78-A(6): 826-834, 1996).

[004] Relative to OS, physicians have long recognized the need to provide warmth and cooling directly to patients as part of OS therapy. Better recoveries have been reported, for example, using cold therapy for orthopedic patients. The benefits of warming patients undergoing surgery has also been demonstrated. It may also be desirable to cool portions of a patient’s anatomy in certain circumstances. Yet another advantageous therapy is the application of heat then cold to certain injured areas. See, for example, U.S. Patent No. 5,989,285 (the ‘285 Patent) assigned to Thermotek, Inc.

[005] Several devices have been developed that deliver temperature-controlled fluids through pads or convective thermal blankets to achieve the above thermal purpose. Typically these devices have a heating or a cooling element, a source for the fluid, a pump for forcing the fluid through the pad or blanket, and a thermal interface between the patient and the temperature-controlled fluid. U.S. Patent No. 4,884,304 to Elkins is directed to a mattress-cover device that contains liquid flow channels that provide the selective heating or cooling by conduction.

[006] Devices have also been developed for providing heat to a person in bed. Electric blankets containing electric heating elements have been used for years to warm a person in bed. Cooling blankets, such as the blanket disclosed in U.S. Patent No. 4,660,388 to Greene, have also been proposed. Greene discloses a cooling cover having an inflatable pad with plenum chambers at opposite ends thereof. Cool air is generated in a separate unit and directed to the pad and out a number of apertures on the underside of the pad and against the body of the person using the cover.

[007] A disposable heating or cooling blanket that has three layers of flexible sheeting is disclosed in U.S. Patent No. 5,125,238 to Ragan, *et al.* Two of the layers form an air chamber and the third includes a comfortable layer for contact with the patient. Conditioned air is directed toward the covered person through a multiplicity of orifices in the bottom layers of the blanket.

[008] The temperature-controlled blanket and bedding assembly disclosed in the '285 Patent includes a temperature-controlled blanket and temperature-controlled bedding system that provide both recirculating temperature-controlled fluid and temperature-controlled gas to enhance performance for convectively heating or cooling a patient. Counter-flow or co-flow heat-exchanging principles between the temperature-controlled liquid and the temperature-controlled gas achieve temperature uniformity across different sections of the blanket and the bedding system. Drapes and the temperature-controlled bedding system provide a temperature-controlled envelope around a person using the bedding system. In one embodiment of the bedding system, an air portion of the bedding system is provided that supplies a fluid portion of the overall bedding system. In another embodiment of the bedding system, the fluid portion of the bedding system is provided for use with a patient bed that supplies the air portion of the overall bedding system.

[009] U.S. Patent No. 5,097,829 to Quisenberry describes an improved temperature-controlled fluid-circulating system for automatically cooling a temperature-controlled fluid in a thermal blanket with a thermoelectric-cooling device having a cold side and a hot side when powered by electricity. The temperature-controlled fluid is cooled by a cold side of the cooling device and is pumped through, to, and from the blanket through first and second conduits.

### **BRIEF SUMMARY OF THE INVENTION**

[0010] The present invention relates to thermal therapy and DVT compression system for use in heating or cooling a patient. In one aspect of the invention, a DVT therapy system includes at least a control unit adapted, a thermal-treatment blanket, a compressive-therapy treatment device, a first set of connector tubes, and a second set of connector tubes. The control unit is adapted to heat and cool a heat-transfer liquid within about 37-105° F and to

provide compressed air at a pressure of at least 25 mmHg above ambient atmospheric pressure. The thermal-treatment blanket is adapted for receipt of the transfer liquid from the control unit and to send the heat-transfer liquid back to the control unit, a compressive-therapy treatment device adapted to utilize the compressed air from the control unit, and a first and second set of connector tubes. The first set of connector tubes is adapted to facilitate the flow of the heat-transfer liquid between the control unit and the thermal treatment blanket. The second set of connector tubes is adapted to facilitate the flow of the compressed air between the control unit and the compressive treatment device.

[0011] In another aspect, a DVT method includes providing a control unit adapted to heat and cool a heat-transfer liquid to a temperature within the range of about 37-105° F and adapted to provide compressed air at a pressure of at least 25 mmHg above ambient atmospheric pressure, providing a thermal treatment blanket adapted for receipt of the heat-transfer liquid from the control unit and for sending the heat-transfer liquid back to the control unit, and applying a hot or cold treatment to an individual's skin area. The method also includes providing a compressive-therapy treatment device utilizing the compressed air from the control unit and applying a compressive treatment to an individual's skin area. The method further includes providing a first set of connector tubes adapted to connect the control unit and the thermal treatment blanket to facilitate the flow of the heat-transfer liquid therebetween, and providing a second set of connector tubes adapted to connect the control unit and the compressive treatment device to facilitate the flow of the compressed air therebetween.

[0012] In a further aspect of the invention, a DVT therapy treatment device includes an upper and lower sheet of biocompatible material, a first air-tight, inflatable portion, a second air-tight inflatable portion, a first hook-and-loop fastener, a second-hook-and-loop fastener, and an inlet. The upper and lower sheet sheets have substantially the same shape and are sealed on an outer edge thereof. The first air-tight inflatable portion includes an elongated strap formed from both the upper and lower sheets, with the elongated strap being adapted to wrap around an individual's ankle. The second air-tight inflatable portion is attached to the first portion, has two longer sides that are relatively pinched at a location generally in the middle of the longer sides and two shorter sides, and is formed from the upper and lower sheets. The first hook-and-loop fastener is on a distal end on the first portion

at a location away from the second portion. The second hook-and-loop fastener is disposed on a left edge of the second portion and is adapted to mate with the first hook-and-loop fastener to secure the DVT therapy device to the individual's foot for subsequent compressive therapy.

[0013] In yet another aspect of the invention, a DVT therapy device includes a first and second sheet of biocompatible material of a generally trapezoidal shape having concentric arcuate top and bottom edges, the first and second sheet being sealed on an outer edge thereof to create an air-tight inflatable structure, a first and second weld located symmetrically about the center of the first and second sheet, a third and fourth weld extending from the first and second welds respectively to create an 'S' shaped portion disposed in the center of the first and second welds, and an inlet for receipt of compressed air from the control unit, the inlet allowing the compressed air to inflate the 'S' shaped portion to facilitate compressive treatment of the individual's calf.

[0013a] In yet another aspect of the invention, there is provided a deep-vein-thrombosis (DVT) therapy device comprising: an upper and lower sheet of biocompatible material, the upper and lower sheets having substantially the same shape and being sealed on an outer edge thereof; a first air-tight, inflatable portion, the first air-tight inflatable portion comprising an elongated strap formed from both the upper and lower sheets, the elongated strap being adapted to wrap around an individual's ankle; a second air-tight inflatable portion attached to the first portion, the second air-tight inflatable portion having two longer sides that are relatively pinched at a location generally in the middle of the longer sides and two shorter sides and being formed from the upper and lower sheets; a first hook-and-loop fastener on a distal end on the first portion at a location away from the second portion; a second hook-and-loop fastener disposed on a left edge of the second portion, the second hook-and-loop fastener adapted to mate with the first hook-and-loop fastener to secure the DVT therapy device to an individual's foot for subsequent compressive therapy; and an inlet located on the lower sheet to facilitate the intake and exhaust of air.

## BRIEF DESCRIPTION OF THE DRAWINGS

[0014] A more complete understanding of the method and apparatus of the present invention may be obtained by reference to the following Detailed Description when taken in conjunction with the accompanying Drawings wherein:

[0015] FIGURE 1 is a perspective view of a thermal and compression-control system for thermal and compression therapy relative to the prevention of DVT;

[0016] FIGURE 2 is a cut-away, perspective view of the system of FIGURE 1 illustrating various elements thereof;

[0017] FIGURE 3 is a cut-away, perspective view of the system of FIGURE 1 taken from the opposite side of that in FIGURE 2;

[0018] FIGURE 4 is a rearwardly oriented, perspective view of the system of FIGURE 1;

[0019] FIGURE 5 is a diagrammatic schematic of the system of FIGURE 1, illustrating integration of thermal and compression elements therewith;

[0020] FIGURE 6 is a flow diagram illustrating a thermal therapy and DVT compression process;

[0021] FIGURES 7-10 illustrate various embodiments of the present invention;

[0022] FIGURES 11A-11G illustrate a DVT-foot wrap;

[0023] FIGURE 12 is a schematic illustrating utilization of one embodiment of the control unit with a more detailed illustration of a thermal therapy blanket;

[0024] FIGURE 13A is a flow diagram of one aspect of the thermal operation of the thermal therapy system as represented in FIGURE 12;

[0025] FIGURE 13B is a rear view of an integrated reservoir and heat transfer assembly (HTA);

[0026] FIGURE 13C is a perspective view of an integrated reservoir and HTA according to a preferred embodiment of the present invention;

[0027] FIGURE 14 is a plan view of an embodiment of a thermal therapy blanket;

[0028] FIGURE 15 is a cross-sectional view of the blanket of FIGURE 14 illustrating flow of thermal fluid therein and utilization of compression air thereabove for use in achieving a compression of the thermal fluid against the skin of a patient;

[0029] FIGURE 16 is a thermal therapy/DVT system block diagram;

[0030] FIGURE 17 is a DVT therapy block diagram further illustrating the operation thereof;

[0031] FIGURES 18A-18D illustrate a DVT calf wrap; and

[0032] FIGURE 19 is a plan view of an embodiment of a thermal therapy blanket..

## **DETAILED DESCRIPTION OF ILLUSTRATIVE EMBODIMENTS OF THE INVENTION**

[0033] Applicants have discovered that the use of both thermal therapy and compression therapy during and for post-surgical treatment for the prevention of DVT is advantageous. As referenced above, numerous articles have been written on the problems associated with DVT and the utilization of thermal therapy is already well known. Consistent therewith, methods of and apparatuses for providing pressurized and thermally controlled fluids for use with patients in need of such therapy are disclosed. A versatile control unit is adapted for providing one of a plurality of treatment modalities. As described below, in one modality, a thermally controlled liquid is produced and provided in a configuration facilitating flow through a treatment pad or blanket for thermal therapy. In a second embodiment, air compression is provided such that a blanket can receive a flow of pressurized air to cause a degree of compression relative to the patient. In a third embodiment, DVT system modules are provided so that the prevention of DVT can be afforded. In a fourth embodiment, thermal therapy is provided with DVT treatment.

[0034] As further described below, a control unit will be shown to be provided with (a) thermally controlled fluid, (b) thermally controlled fluid and compression air, and (c) thermally controlled fluid, compression air, and DVT systems. The control unit for providing these selective features is described within a single chassis design capable of providing any of the modalities therein or herein described. This selective versatility provides financial and manufacturing incentives in that the simple design selectively can provide an industrial, medical, or electro-optic version that produces only thermally controlled liquid, such as co-liquid for cooling industrial equipment, in a configuration adaptable for other applications. Therefore, in one embodiment of the invention, the production of a control unit adapted only for chilling electronic components is conceivable while the same chassis and initial components placed therein may also be adaptable for a version that provides a prophylaxis for DVT.

[0035] Referring first to FIGURE 1, there is shown a thermal and compression-control unit 4 for thermal and compression therapy. The control unit 4 is coupled to thermal and compression elements applied to a patient as described below. In this particular view, the

control unit 4 is shown in perspective to illustrate the assembly of one embodiment of a control unit for pumping air and liquid through tubes to be described below for a patient to be treated therewith.

[0036] Referring still to FIGURE 1, a lower dark portion thereof includes a filter that is removable from around a grate as illustrated below. In one embodiment, the filter provides an air-filtering substance such as woven netting that is attached by VELCRO fasteners or the like outwardly of a perforated metal grate to allow for the low pressure drawing of air therethrough to allow cooling of components placed inwardly therein prior to the upward draw of the air through fans disposed thereabove and the forcing of said air upwardly across a heat transfer assembly (HTA) 202 as presented in FIGURE 2.

[0037] Referring now to FIGURE 2 specifically, the HTA 202 is shown disposed beneath a fluid reservoir 200. The reservoir 200 is adapted for storage of liquid that may be pumped outwardly through a fluid connector disposed rearwardly of the reservoir 200. Fluid connector 200A is adapted for connecting to the patient pads or blankets as described below.

[0038] Still referring to FIGURE 2, there is shown the internal portion of the control unit 4 referenced above illustrating one embodiment of the assembly therein. Within the assembly of the unit 4, a pair of fans 71 and 73 are shown disposed above a grate 75. Grate 75 contains therearound the filter portion 77 that may be secured thereto by hook and loop (e.g., VELCRO). The lower portion of the grate is connected to a bottom portion 79 of a chassis 81 in a manner to provide support for electronic components 83 mounted thereon for providing the adequate power supply to and control of the HTA 202 and other elements within the control unit 4.

[0039] Referring specifically now to a dual-fan arrangement, fans are positioned to suck air from around the filtered grated region disposed peripherally about the electronic components so that the air flow is both quiet and at a rate allowing initial electronic cooling and then being available to be pushed into the top section of the control unit 4 where most heat dissipation is needed. In essence, the control unit 4 facilitates pulling air through the lower power supply that could then be forced upwardly for maximum cooling where maximum thermal change is needed.

[0040] Referring still to FIGURE 2, an air pump 85 is disposed in a lower portion of a chassis 81 and beneath an air switch 87 disposed beneath a heat sink 89 disposed adjacent to a fluid pump 91. The fluid pump 91 is disposed in position for collecting fluid from a reservoir 200 that has been thermally controlled by the HTA 202 for passage through the fluid connector 200A. Thermal electric chips (TEC chips) 93 are shown disposed between the heat sink 89 and a thermal transfer plate 95 in a manner to provide the requisite thermal control of the fluid within the reservoir 200. An air connector 97 is shown disposed adjacent to the fluid connector 200A to provide the requisite dissipation of air from the air pump 85 for use in conjunction with the blanket 8 for application of pressure in a bladder forcing the thermal fluid flowing from the fluid connector 200A to be in close contact with the patient as described below.

[0041] Referring now to FIGURE 3, there is shown a cutaway perspective view of the control unit 4 taken from the opposite side thereof and illustrating various other aspects therein. Relative to this particular view of the control unit 4, a 500-watt power supply is shown disposed along with a 65-watt power supply relative to the chassis 81. The various power supplies are further defined herein and provide the requisite performance necessary for both flexibility and reliability. In conjunction with the DVT therapy operation, a DVT air pump 119 is shown disposed adjacent to a pair of DVT solenoids 121 mounted on a DVT air bracket 123 adjacent a DVT air switch 125. A pair of solenoids 127 are likewise disposed relative thereto.

[0042] Referring now to FIGURE 4, there is shown a rearward-oriented perspective view of the control unit 4 illustrating the connectors and couplings on the rear panel of the control unit 4 as provided for the functionality described herein. In this particular view, it may be seen that a single air connector is provided for pressurization of the blankets as described below. Likewise, a pair of fluid connectors are provided in that the fluid flow requires an outward bound and an inward bound flow of fluid to the fluid reservoir for thermal control. Likewise, the DVT connectors are provided in a pair, although a single DVT connector is used for each DVT pad. The DVT pads are pressurized in accordance with the medical modality described herein and the parameters are set by the programming within the control boards of the control unit 4. Also shown in the figure is an RS232 connector for data

communication with the control unit 4. Other connections are contemplated by the Applicants such as, for example, a USB connection or a wireless connection.

[0043] Referring now to FIGURE 5, there is shown a thermal compression-control system for thermal compression therapy wherein the control unit 4 is coupled to a thermal blanket 8 by connector tubes 6 coupled to the control unit 4 through a connector 10. The DVT prevention aspect is provided through a cuff system 31 comprising cuffs 33 and 35 that allow placement on the feet or other select regions of a patient for the DVT treatment thereof. The cuffs 33 and 35 are coupled to the control unit 4 through connector tubes 37.

[0044] Relative to the DVT pulsing, various embodiments of the present invention provide for a broad pulse configuration. It has been reported that a narrow pulse generated by opening a solenoid on compressed air may be hazardous due to the intensity of the pulse damaging cells. A broader pulse as described herein will apparently not cause the same degree of harm and may reduce harm while maintaining the same degree of efficiency in the DVT prevention. The other solenoids shown herein permit choosing between the right or left routing of the compression stroke as further defined in other figures.

[0045] Referring back to FIGURE 5, it may be seen that the connector tubes 37 are mounted to the DVT connectors shown on the rear panel of the control unit 4 wherein each may provide a pressurized air in accordance with a pre-programmed application that maximizes the effectiveness of the DVT prophylaxis. In accordance with principles of the present invention, one activation technique is a high pressure low ramp-up sequence wherein the select pressure for DVT prevention is provided without a high pulse rate. It has been found by the Applicants that a high pulse rate time has been reported to create in part cell damage and it is advantageous in such a DVT prevention system to modify the conventional pulse rate to reduce cell damage. In this manner, the control boards of the control unit 4 provide a select pressurization in utilization with the solenoids shown mounted within the DVT system to carefully control the pulse ramp time in accordance with maximum medical treatment of the patient pursuant to medical concerns for such treatment.

Application	Source	Mode	Pressure, mmHg	Deflation Pressure, mm HG	Inflation Time, s	Hold Time, s	Cycle Time, s	Comments
Calf	Literature	Both	30-80	0	3-20	1-5	30-80	Predominantly alternating with some simultaneous
	Existing Product	Alternating	~45	0	Inc.	12	60	Calf and Foot
	ThermoTek	Alternating	45	15	8	1-5		Additional solenoid, line, and Colder connector
Foot	Literature	Alternating	45-180	0	0.3-5	1-5	20-60	Predominantly higher pressures 3 sec "std"
	Existing Product	Alternating	120-180	0	0.3	1-5	20-60	
	ThermoTek	Alternating	120	15	9	2-5	30	Additional air pump, line, and fitting

Table 1

[0046] Table 1 illustrates information regarding an embodiment of the invention relative to various existing products on the market for addressing calf and foot DVT concerns. All pressure references in Table 1 pertain to mmHg above the ambient atmospheric pressure. It will be seen from Table 1 that currently available literature indicates an inflation time of 3-20 seconds for a calf and around .3 seconds for a foot. Such inflation times are different than those typically used by the Applicants and Applicants' assignee "ThermoTek" as referenced in Table 1 wherein the inflation time for one embodiment of the system of the present invention is on the order of 8 seconds for a calf in an alternating mode. Likewise, relative to the foot, which is often specifically of concern, an inflation time on the order of 9 seconds as compared to existing literature and existing information regarding a commercially available product in the range of .3 seconds. This differential is, as referenced above, a much more gradual pulse rate and is currently understood by Applicants to create less cell damage for DVT treatment. The information presented above includes preferred ranges while other times are contemplated by the Applicants to be capable of achieving the desired results.

[0047] Referring now to FIGURE 6, there is shown a flow diagram illustrating one embodiment of the present invention wherein the patient is initially connected to the system of control unit 4 in step 831. Next, the control unit 4 is activated for thermal therapy in step

833 and activated for DVT compression in step 835. The condition of the patient is monitored in step 837 and the control parameters are adjusted in step 839 for further monitoring of the patient. Adjustments in step 839 follow monitoring the patient in step 837 as long as the system is in operation.

[0048] Referring now to FIGURES 7-10 together, each shows an application of an embodiment of the present invention. In FIGURE 7, an industrial example is illustrated wherein a cooling umbilical is provided from control unit 4, which cooling umbilical may be utilized to cool electronic equipment as therein illustrated. Likewise in FIGURE 8, the control unit 4 is shown to be connected with three tubes to provide a cooling umbilical for an individual having thermal therapy therewith. The cooling umbilical is also connected with an air line that allows an inflation of the particular wrap shown around the user's knee in this particular view for purposes of applying pressure thereagainst. This particular thermal therapy wrap or blanket will be illustrated in more detail below.

[0049] Referring now to FIGURE 9, there is shown utilization of the control unit 4, wherein a cooling umbilical is utilized without any compression and DVT compression is provided for both feet or calves of a patient to illustrate DVT and thermal therapy usage. In FIGURE 10, only DVT is being utilized from the control unit 4 as no thermal therapy umbilicals are therein utilized.

[0050] Referring now to FIGURE 11A, there is shown a DVT flat foot blanket layout 1100 of the type that may be used in accordance with the principles of the present invention. Because of the generic shape of the flat foot blanket layout 1100, a foot wrap based on the layout 1100 may be used on either a left or right foot. It may be understood that a variety of blanket layouts may be utilized for the foot during DVT treatment. It is thought that these illustrations as depicted in FIGURES 7-11 will further facilitate an understanding of principles of the present invention and enable one skilled in the art to practice same in conjunction with the control unit 4 as described herein.

[0051] Referring now to Figures 11B-11C, there is shown a contoured foot wrap 1104. The foot wrap 1104 is formed from a first sheet of biocompatible material 1102 and a second sheet of biocompatible material 1116 that are sealed together at sealed edge 1110.

The first sheet of biocompatible material 1102 and the second sheet of biocompatible material 1116 include the front and back of the foot wrap 1104, respectively. The foot wrap 1104 includes an upper air-tight inflatable portion 1106 and a lower air-tight inflatable portion 1108. The lower air-tight inflatable portion 1108 also includes flaps 1112 and 1114. In various embodiments, flap 1114 and the upper air-tight inflatable portion 1106 include a hook-and-loop fastener hook sealed or sewn onto their front sides and the back is Velcro® compatible to receive the hooks. An inlet is located on the back of the foot wrap 1104 on the lower air-tight inflatable portion 1108 to facilitate the intake and exhaust of air.

[0052] Referring now to Figures 11D-11G, the operation of the foot wrap 1104 is described. With reference to Figure 11D-11E, a foot is placed into the foot wrap 1104 with the foot engaging the front side 1102 of the foot wrap 1104. With reference to Figures 11E-11F, the flaps are pulled tight and the foot wrap 1104 is secured. The contoured foot wrap 1104 may be now be connected to the control unit 4 via a DVT connector 37 connected to inlet for DVT therapy according to the present invention, as depicted in Figure 11G.

[0053] Referring now to Figures 18A-18B, there is shown a trapezoidal DVT calf blanket 1802 of the type that may be used in accordance with principles of the present invention. As with the flat foot blanket layout, a variety of blanket layouts may be used for the calf during DVT treatment. A calf wrap 1802 is formed of two sheets of biocompatible material 1800 and 1820, including the front and back of the calf wrap 1802, respectively. The front 1800 and back 1820 are sealed or sewn together at a sealed edge 1810. Additionally, the calf wrap is divided into three chambers (1804, 1806, and 1808) by welds 1812 and 1814. The middle chamber 1806 is characterized by two additional welds 1816 and 1818. Weld 1816 extends from weld 1812 and weld 1818 extends from weld 1814, creating an 'S' shaped chamber. The three-chamber structure as described herein permits a compression gradient across the three chambers. In various embodiments, all welding may be accomplished by radio frequency (RF) welding. The front side 1800 also includes flaps 1824 and 1810. In various embodiments, flap 1824 may have sealed or sewn thereon a Velcro® hook and back side 1820 may be Velcro® compatible to receive the hook. An inlet 1822 is located on the back of the calf wrap 1802 to facilitate the intake and exhaust of air.

[0054] Referring now to Figures 18C-18D, operation of the calf wrap 1802 is described. With reference to Figure 18C, the calf wrap 1802 is positioned on the front side of the calf. Flap 1826 is pulled tight and then flap 1824 is pulled tight overtop and attached. With reference to Figure 18D, the calf wrap may be connected to the control unit 4 for DVT therapy according to the present invention by connecting DVT connector 37 to inlet 1822.

[0055] Referring now to FIGURE 12, there is shown a thermal therapy application without pressure applied (similar to the thermal therapy illustrated in FIGURE 9). As shown herein, heat transfer fluid flows into the blanket 8 through an inlet port, and exits through an outlet port to the control unit 4 via the connector 10 and connector tubes 6. Gas may be pumped by the control unit 4 to the blanket 8 through the connector tubes 6 and the connector 10 to provide compression (not shown in this view). While the embodiment described above pumps gas to provide compression, it is also contemplated that other substances could be utilized to provide the desired compression.

[0056] The control unit 4 and the blanket 8 may be adapted for the administration of hot, cold, and/or compression therapies to a body portion of the patient. For example, the blanket 8 may cover different areas of the human body. Current thermal design requirements for temperature therapy in various embodiments of the present invention are as follows: 1) the system must be able to heat the fluid from around 49°F to around 105°F with the largest blanket attached to a typical man (e.g., 5'10" and 180 lbs.) at an ambient of 77°F within 10 minutes; 2) the system must be able to cool the fluid from 105°F to 49°F with the largest blanket attached to the typical man at an ambient of 77°F within 20 minutes; and 3) the system must cool the fluid to 37°F at an ambient of 77°F within 90 minutes. These requirements should be with a minimum compression of 25 mm Hg. The connector 10 provides a fluid and/or gas connection between the control unit 4 and the blanket 8 for the transfer of gas and heat transfer fluid. The connector 10 may also allow for transfer of electrical sensor signals and/or data signals between the blanket 8 and the control unit 4. The emergency relief valve 9 is utilized to quickly decompress the blanket 8 if needed.

[0057] Referring now to FIGURE 13A, a block diagram of one embodiment of the flow of heat transfer fluid between the control unit 4 and the blanket 8 is illustrated. The control unit 4 includes a heat transfer fluid reservoir 200 and at least one heat transfer

assembly (HTA) 202 for heating and/or cooling the heat transfer fluid. Before the blanket 8 is utilized for temperature therapy, the system is primed with the heat transfer fluid. When the system is primed, substantially no air exists in the tubes 204 between the reservoir 200, HTA 202, and blanket 8. The flow tubes in the control unit 4 between the reservoir 200, HTA 202, and blanket 8 form a three-point junction 204C. In embodiment, the three-point junction 204C is formed as an inverted Y, however, other shapes and orientations are possible. By utilizing a three-point junction 204C, the heat transfer fluid returning from the blanket 8 is recirculated to the HTA 202 without utilizing heat transfer fluid from the reservoir 200. The three-point junction 204C allows the HTA 202 to heat or cool the heat transfer fluid that has already been heated or cooled prior to entering the blanket 8. In the preferred embodiment, the HTA 202 does not heat or cool the entire contents of the reservoir 200, but merely the portion of the heat transfer fluid that is currently circulating through the blanket 8 and tubing 204. The reservoir is typically by-passed unless more fluid volume is needed. In the three-point junction 204C, heat transfer fluid returning from the blanket 8 may be pulled, via a pump, to the HTA 202. If more heat transfer fluid than that which is already circulating through the system is required, then the heat transfer fluid from the reservoir is introduced into the system.

[0058] Referring now to Figures 13B-13C, the integration of the reservoir 200 and the HTA 202 is illustrated. With reference to Figure 13B, the rear of the reservoir 200 includes a coolant supply port 1302 for supplying heat transfer fluid to the fluid pump 91, a coolant return port 1304 for receiving heat transfer fluid from the blanket 8, and a cold plate 1306. The cold plate 1306 is positioned at the base of the reservoir 200 and is therefore in direct contact on its underside with the TEC 93. Referring now specifically to Figure 13C, a divider 1308 is located in the middle of the reservoir 200 between the coolant supply port 1302 and the coolant return port 1304, thereby blocking direct flow of fluid between the two ports. As fluid flows into the back of the reservoir 200 through the coolant return port 1304, the divider 1308 channels the fluid to the front of the reservoir 200 and then back to the coolant supply port 1302. By preventing fluid from short circuiting directly from the coolant return port 1304 to the coolant supply port 1302, the divider 1308 forces exposure of the fluid to the cold plate 1306 which, as a result of its direct contact with the TEC 93, provides a surface area to cool or heat the fluid. The reservoir 200 also includes vertical fins 1310 to further enhance

contact areas with the fluid. In one preferred embodiment, the vertical fins are spaced 0.5 inches apart and span the length of the reservoir 200.

[0059] Referring now to FIGURE 14, a temperature therapy blanket 8 having a pre-selected shape and compression capabilities is illustrated. The underside of the blanket 8 (shown) is placed directly against a portion of the patient. The fluid bladder is thus adjacent to the patient. Heat transfer fluid flows into the blanket 8 from inlet hose 500 and heat transfer fluid flows out of the blanket via outlet hose 502. A gas for compression flows into the blanket 8 from air inlet hose 504. Heat transfer fluid travels through the inlet hose 500, through fluid inlet port 506, and into the blanket 8. The connections 15 allow the heat transfer fluid to more evenly disperse throughout the fluid bladder. Partitions 508a, 508b control the flow of heat transfer fluid throughout the fluid bladder. Partition 508a prevents heat transfer fluid from entering the blanket 8 at the inlet port 506 and immediately exiting the blanket via outlet port 510. Partition 508a forces the heat transfer fluid to travel towards the end of the blanket 8 remote from the inlet port 506. Partition 508b, in conjunction with connections 15, causes the heat transfer fluid to travel across the width of the blanket 8. The edges of the fluid bladder are joined to the edges of the air bladder at seal 512. The heat transfer fluid may then exit the blanket 8 at the outlet port 510. The travel of the heat transfer fluid is indicated by arrows.

[0060] Referring now to FIGURE 15, the blanket 8 is turned over relative to FIGURE 14 and a cross-sectional view along line A-A of FIGURE 14 is illustrated. As described above, the fluid bladder 514 (disposed against the patient) and the air bladder 516 are joined together at seal 512. Connections 15 join the upper layer and lower layer of the fluid bladder 514 together. The partition 508a segregates the heat transfer fluid from the inlet port 506, illustrated by downward arrows, from the heat transfer fluid flowing to the outlet port, illustrated by the upward arrows. The air bladder 516 is oriented over the fluid bladder 514 and serves to press the fluid bladder 514 against a portion of the patient (not shown in this view). In another embodiment, the fluid bladder 514 and the air bladder 516 may have low-profile inline ports such as inline ports 1902(a)-(c) of a temperature therapy blanket 1900 of FIGURE 19. Inline ports afford increased comfort to a user by allowing the blanket 8 to lay

substantially flat. The embodiment shown allows users to sleep or rest while using the blanket 8.

[0061] Referring now to FIGURE 16, there is shown a thermal therapy/DVT system block diagram where air is provided in a compression subsystem in conjunction with Peltier cooling of a fluid for thermal therapy. The coolant flow is thermally conditioned by the Peltier cooling engine. Patient supply cooling temperature sensors are utilized in conjunction therewith. Coolant pumps are utilized in conjunction with cooling fans. The cooling fans, as described above, provide selective cooling in a manner most efficient for the construction and operation of the control unit 4. In that regard, FIGURE 16 may be utilized in understanding various aspects of operation of the system of the present invention as further defined below.

[0062] Various of the above-described Figures illustrate the mounting of dual-fan assemblies for impinging style airflow. In this manner, the air is brought in at the base of the heat sink and driven in or impinged against the heat sink, which serves to lower the pressure drop and increase air flow for a given heat sink. A single heat sink may be used. Such a configuration of air flow with an enlarged grate configuration may be used to afford noise abatement.

[0063] In one embodiment, the size of the reservoir has been reduced relative to a number of earlier models of thermo-electric (TEC) systems such that only around 175 watts are utilized compared to 205 for typical earlier systems. As such, the control unit 4 is configurable with TEC assemblies maximizing efficiency. With such an assembly, multiple applications of industrial with non-air compression and/or medical with air compression and/or DVT is afforded in a single chassis 81. With regard to the medical modality, thermal therapy may be afforded to a patient to reduce swelling and edema while, in conjunction with the DVT prophylaxis, preventing blood from pooling in lower body extremities. This is particularly important after surgery when anesthesia has been involved. It is well known that anesthetics often tend to reduce the wall strength of veins and, if not otherwise treated, appropriate venous pumping may not be afforded allowing for blood pooling in clots. With the DVT application as disclosed herein, both thermal and DVT prophylaxis with a low-noise configuration may be achieved.

[0064] Still referring to FIGURE 16, the Peltier power supply is shown to be controlled by a pt-7c controller accessed via a keypad display. Various other features for control and power supply have likewise been included, such as an electro-magnetic interference (EMI) filter and auxiliary power supply used in conjunction with the DVT therapy subsystem. It may be seen that the DVT therapy subsystem provides a separate airflow for both left and right applications that were described above for utilization in the DVT treatment of a patient illustrated in FIGURES 9 and 10.

[0065] For purposes of this patent application, the following definitions are to be used:

hot:  $> 15^{\circ}\text{C}$  greater than ambient temperature;

cold:  $< 15^{\circ}\text{C}$  less than ambient temperature;

about: not more than 10% more or less than stated value;

around: not more than 10% more or less than stated value; and

biocompatible: referring to a material that the body generally accepts without a significant immune response.

[0066] Referring now to FIGURE 17, there is shown a DVT therapy block diagram where the air pump is shown to be in flow communication with a compress valve utilized with a vent valve and a pressure sensor in association with a pressure switch high and pressure switch low. This DVT therapy block diagram is provided to further facilitate an understanding of the DVT therapy provided by the control unit 4 in accordance with various embodiments of the present invention when DVT compression is provided from two outlets of the control unit 4. The various modes of operation utilizing air pump, compression valve, select valve, DVT valve, and vent valve are shown.

[0067] The previous description is of embodiments of the invention. The scope of the invention should not necessarily be limited by this description. The scope of the present invention is instead defined by the following claims.

## CLAIMS

1. A deep-vein-thrombosis (DVT) therapy system comprising a DVT therapy device, the DVT therapy device comprising:

an upper and lower sheet of biocompatible material, the upper and lower sheets having substantially the same shape and being sealed on an outer edge thereof;

a first air-tight, inflatable portion, the first air-tight inflatable portion comprising an elongated strap extending in a first direction and being formed from both the upper and lower sheets, the elongated strap being adapted to wrap around an individual's ankle;

a second air-tight inflatable portion attached to the first portion and being formed from the upper and lower sheets, the second air-tight inflatable portion having two longer sides and two shorter sides, the two longer sides extending in a second direction substantially perpendicular to the first direction and being relatively pinched along the second direction at a location generally in the middle of the two longer sides;

a first hook-and-loop fastener on a distal end on the first portion at a location away from the second portion;

a second hook-and-loop fastener disposed on a left edge of the second portion, the second hook-and-loop fastener adapted to mate with the first hook-and-loop fastener to secure the DVT therapy device to an individual's foot for subsequent compressive therapy; and

an inlet located on the lower sheet to facilitate the intake and exhaust of air.

2. The DVT therapy system of claim 1, the DVT therapy device comprising an air-tight bladder to enable simultaneous thermal and compressive treatment.

3. The DVT therapy system of claim 1, comprising:

a control unit;

a first set of connector tubes adapted to facilitate a flow of heat-transfer liquid between the control unit and the DVT therapy device; and

a second set of connector tubes adapted to facilitate a flow of compressed air between the control unit and the DVT therapy device.

4. The DVT therapy system of claim 3, wherein the control unit comprises a heat-transfer liquid reservoir.

5. The DVT therapy system of claim 4, wherein the heat-transfer liquid reservoir is bypassed unless the DVT therapy device requires additional heat-transfer liquid.

6. The DVT therapy system of claim 3, wherein the control unit is adapted to heat the heat-transfer liquid from around 49°F to around 105°F with a large thermal treatment device connected to the control unit and applied to an individual with an ambient temperature of around 77°F within a 10-minute period.

7. The DVT therapy system of claim 3, wherein the control unit is adapted to cool the heat-transfer liquid from around 105°F to around 49°F with a large thermal treatment device connected to the control unit and applied to an individual with an ambient temperature of around 77°F within a 20-minute period.

8. The DVT therapy system of claim 3, wherein the control unit is adapted to provide compressed air at a pressure of at least 25 mmHg greater than ambient atmospheric pressure.

1/14

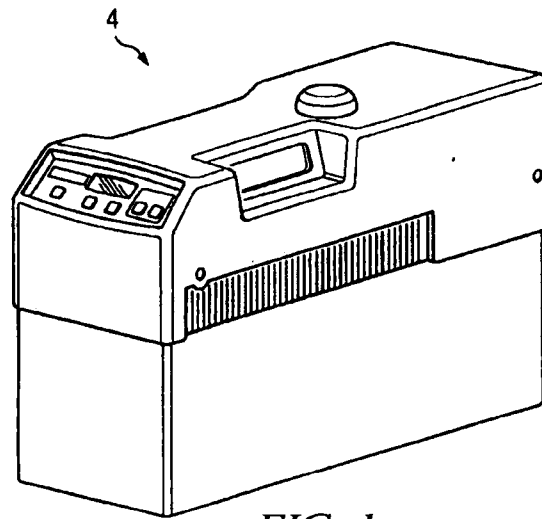

FIG. 1

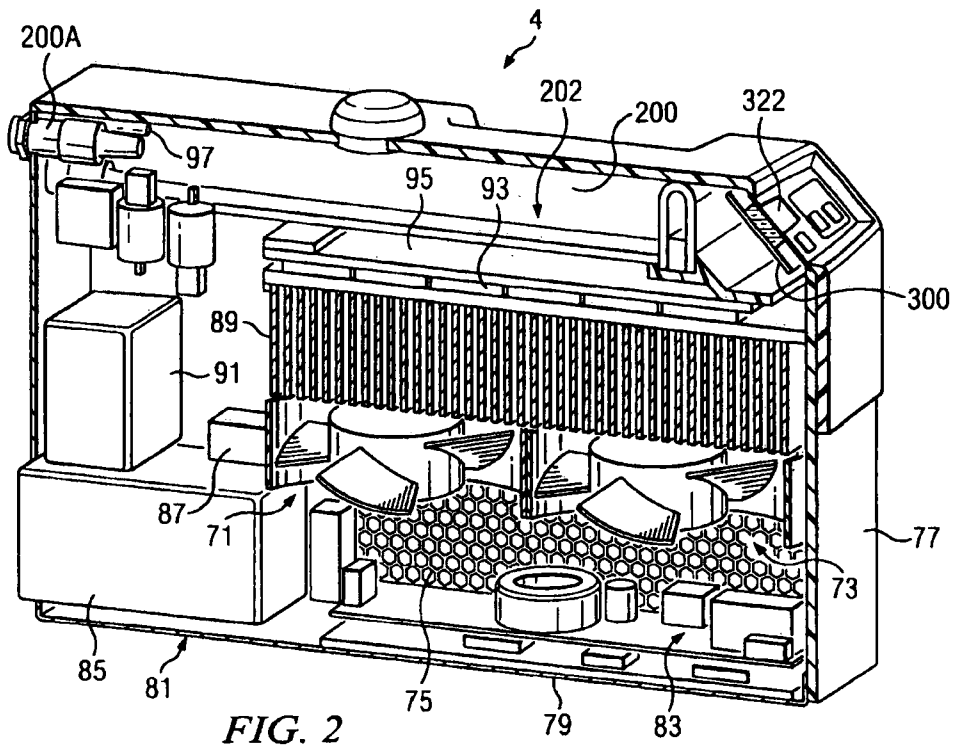
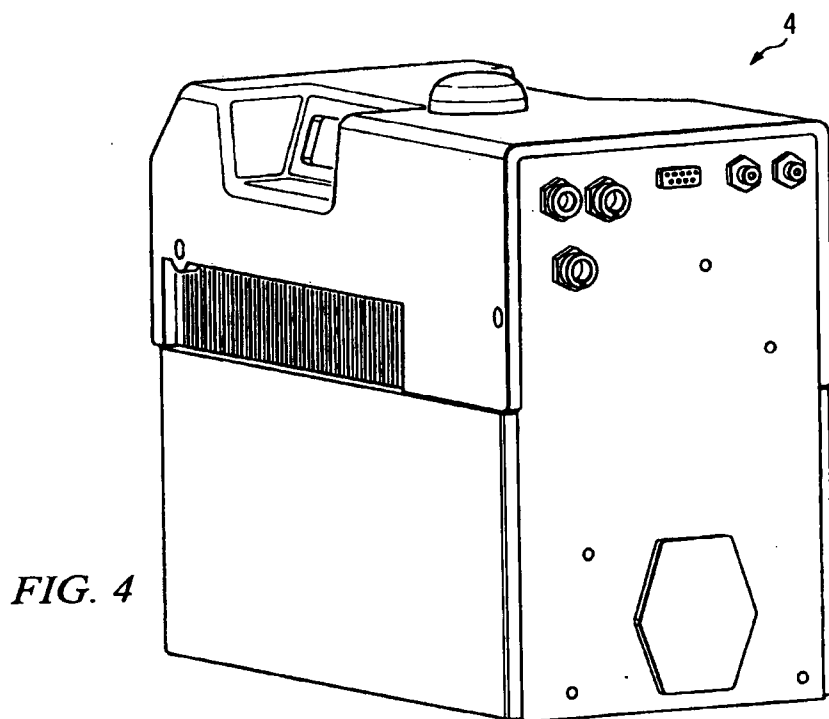
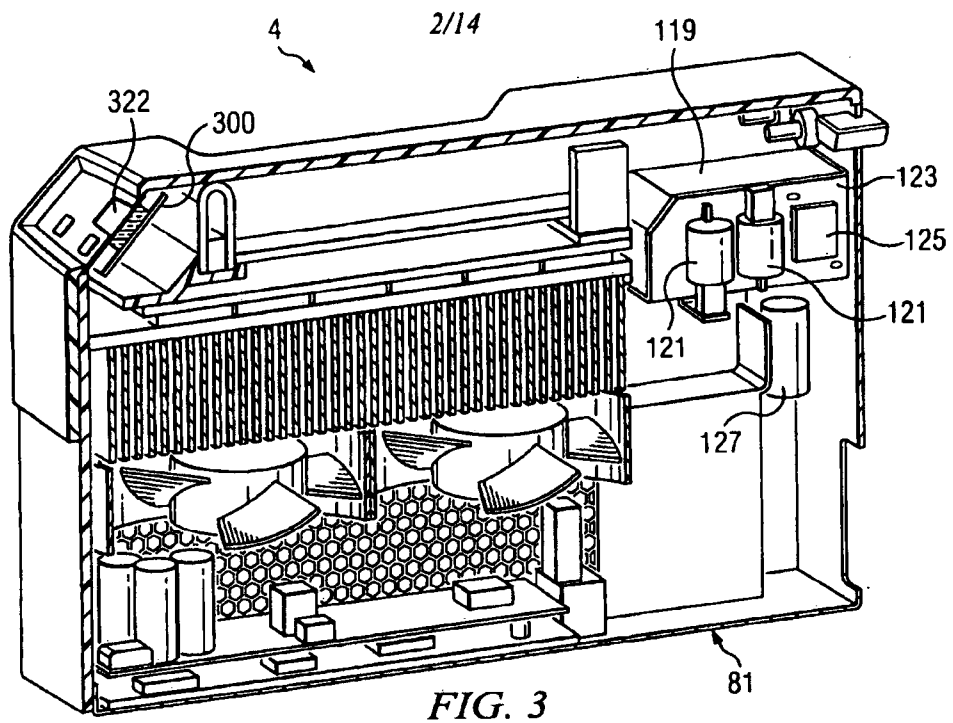

FIG. 2



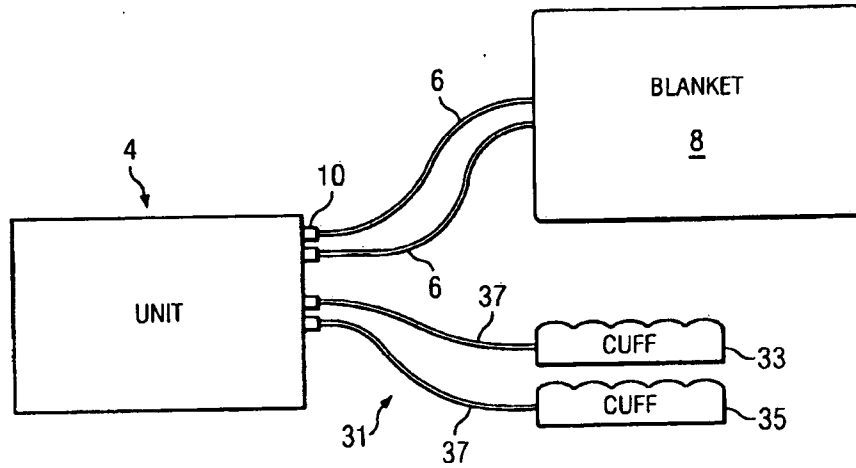

FIG. 5

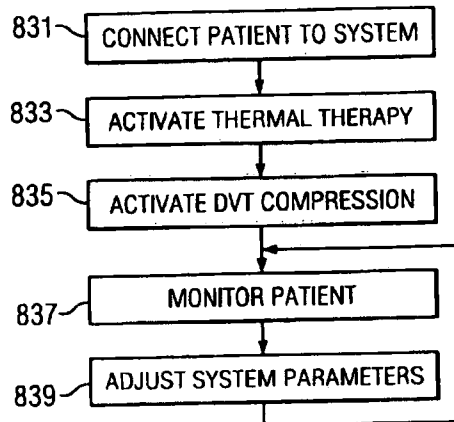

FIG. 6

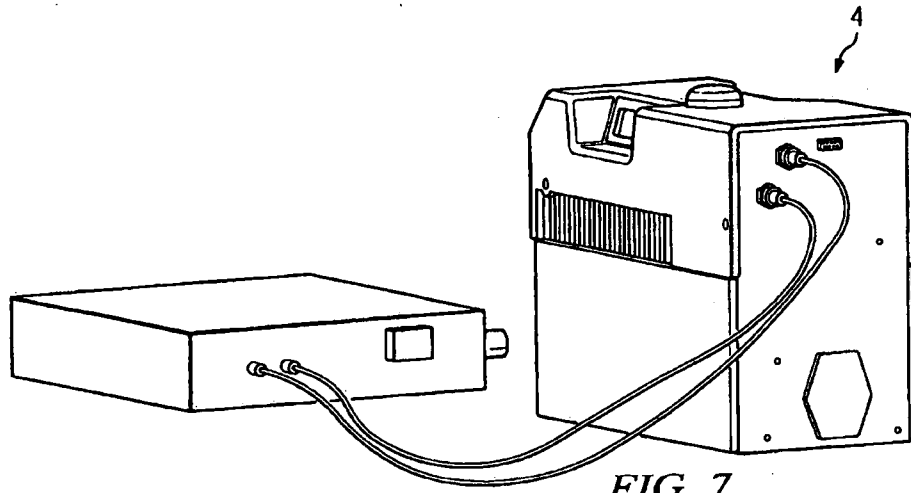

FIG. 7

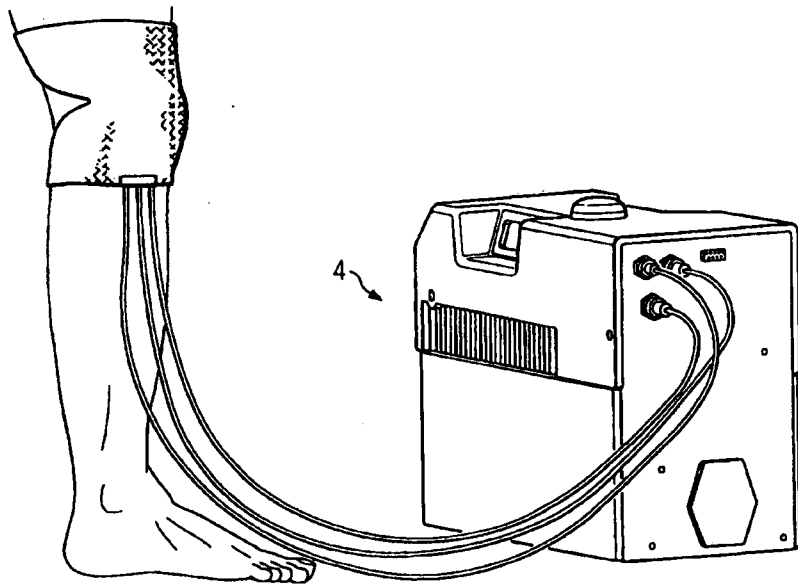

FIG. 8

5/14

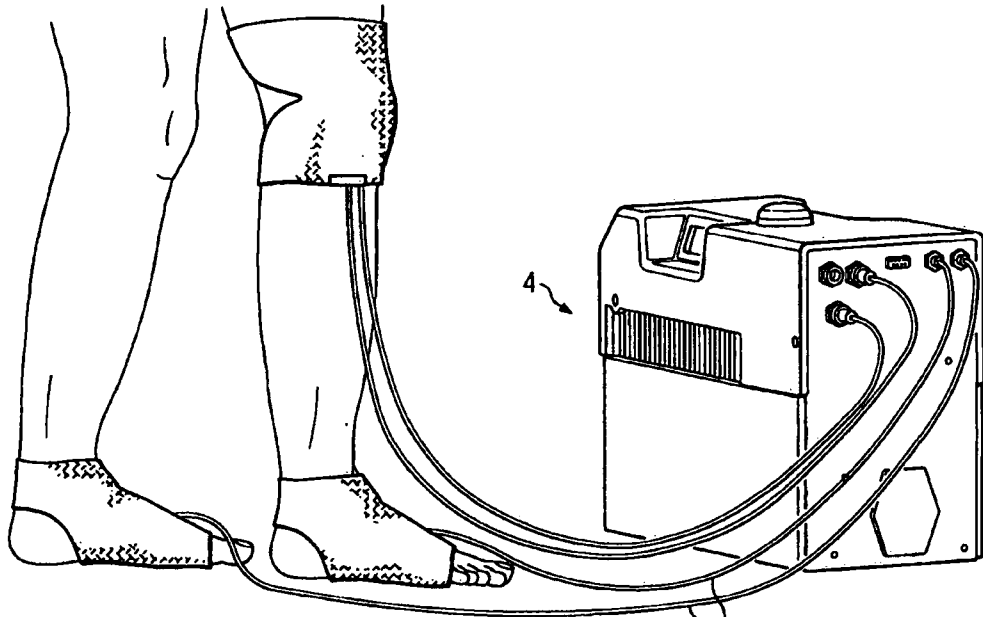

FIG. 9

37

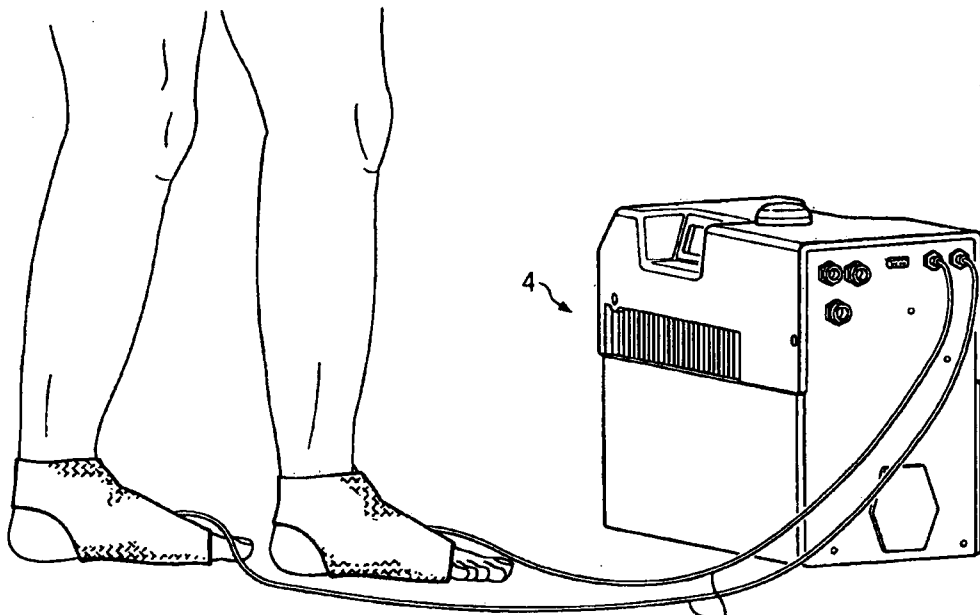

FIG. 10

37

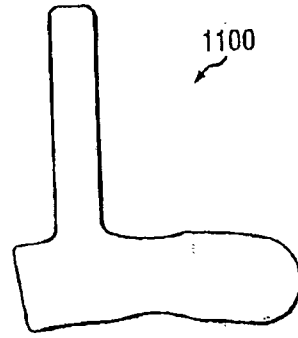

FIG. 11A

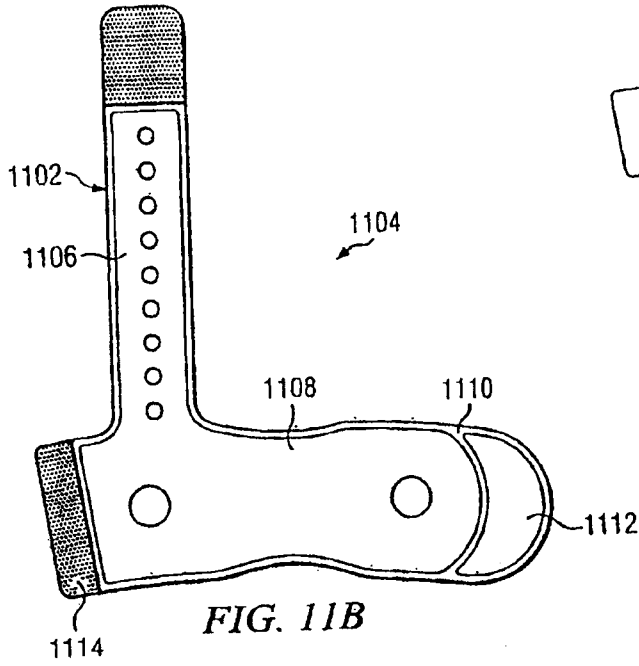

FIG. 11B

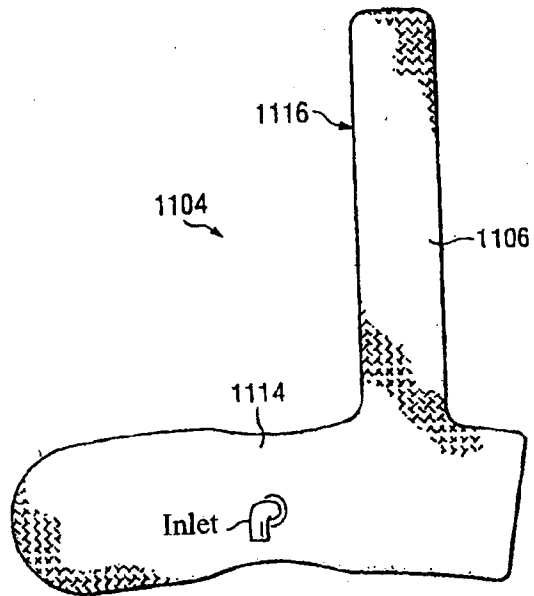
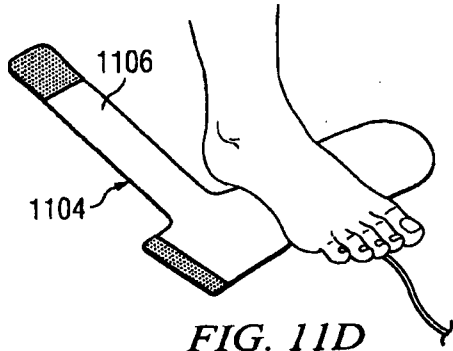
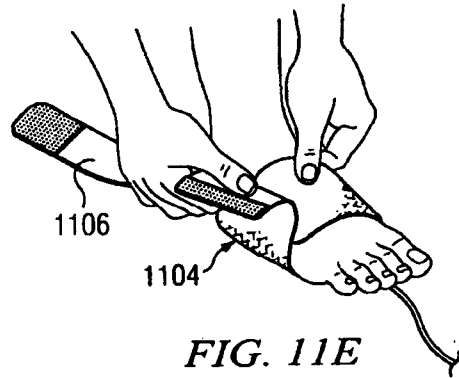

FIG. 11C

7/14



**FIG. 11D**



**FIG. 11E**

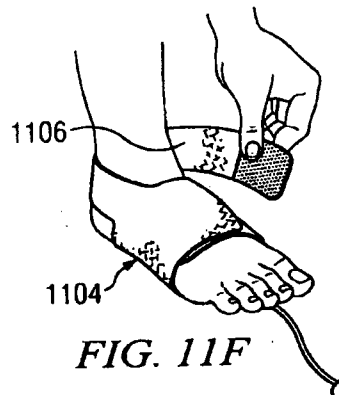

**FIG. 11F**

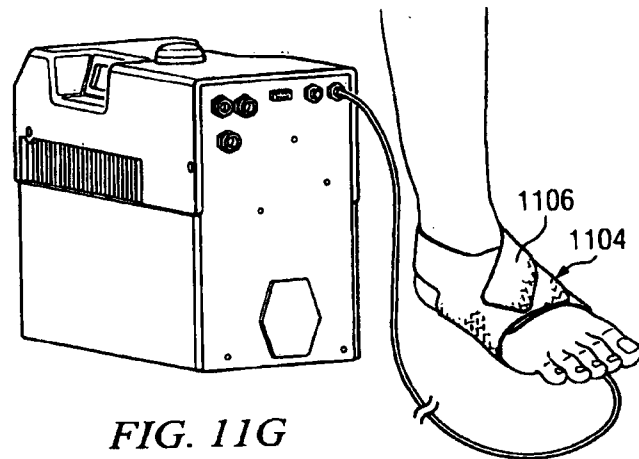

**FIG. 11G**

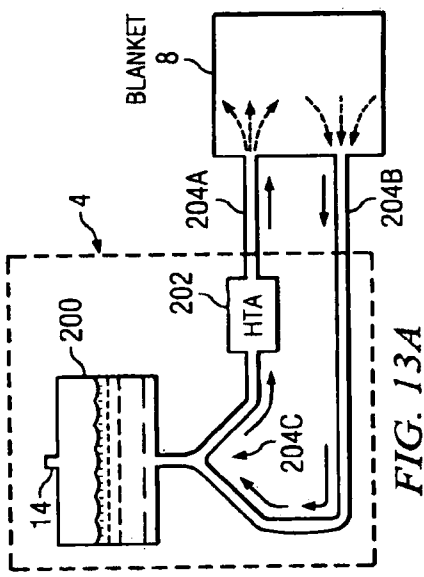

FIG. 13A

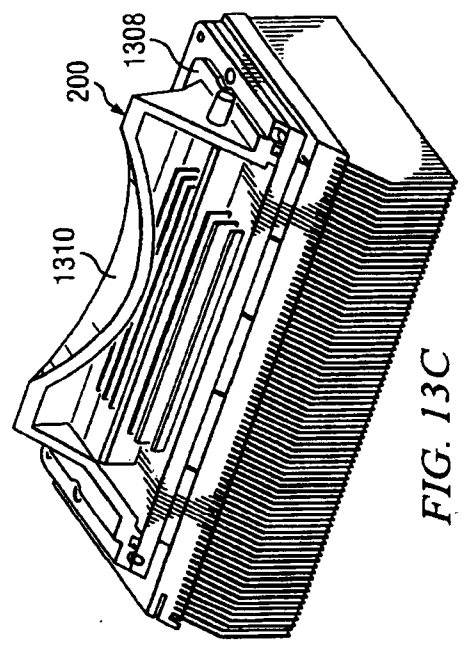

FIG. 13C

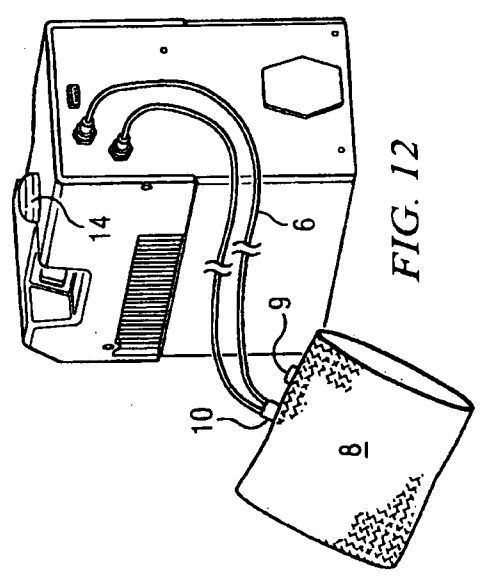

FIG. 12

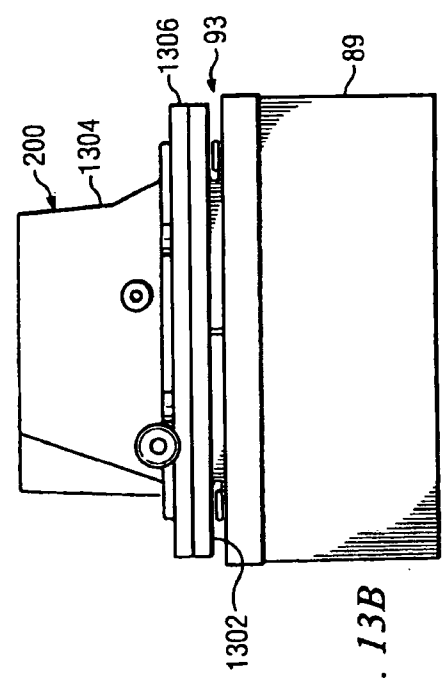

FIG. 13B

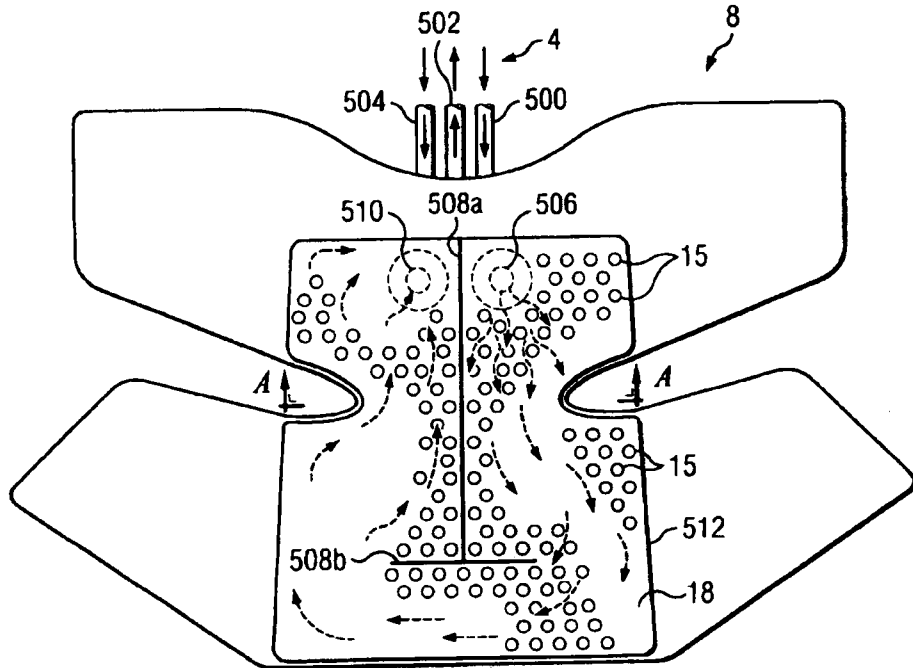

FIG. 14

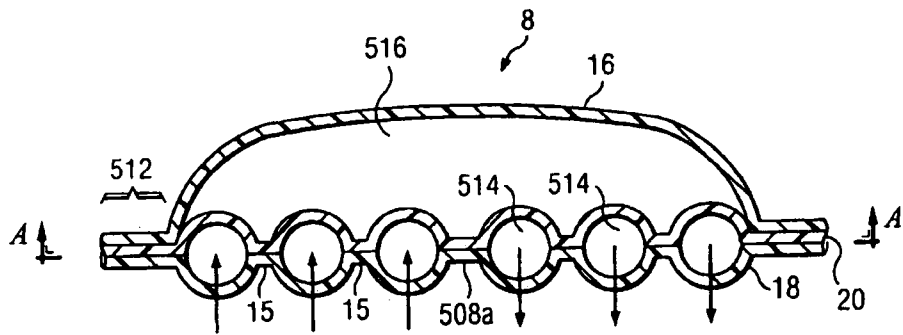

FIG. 15

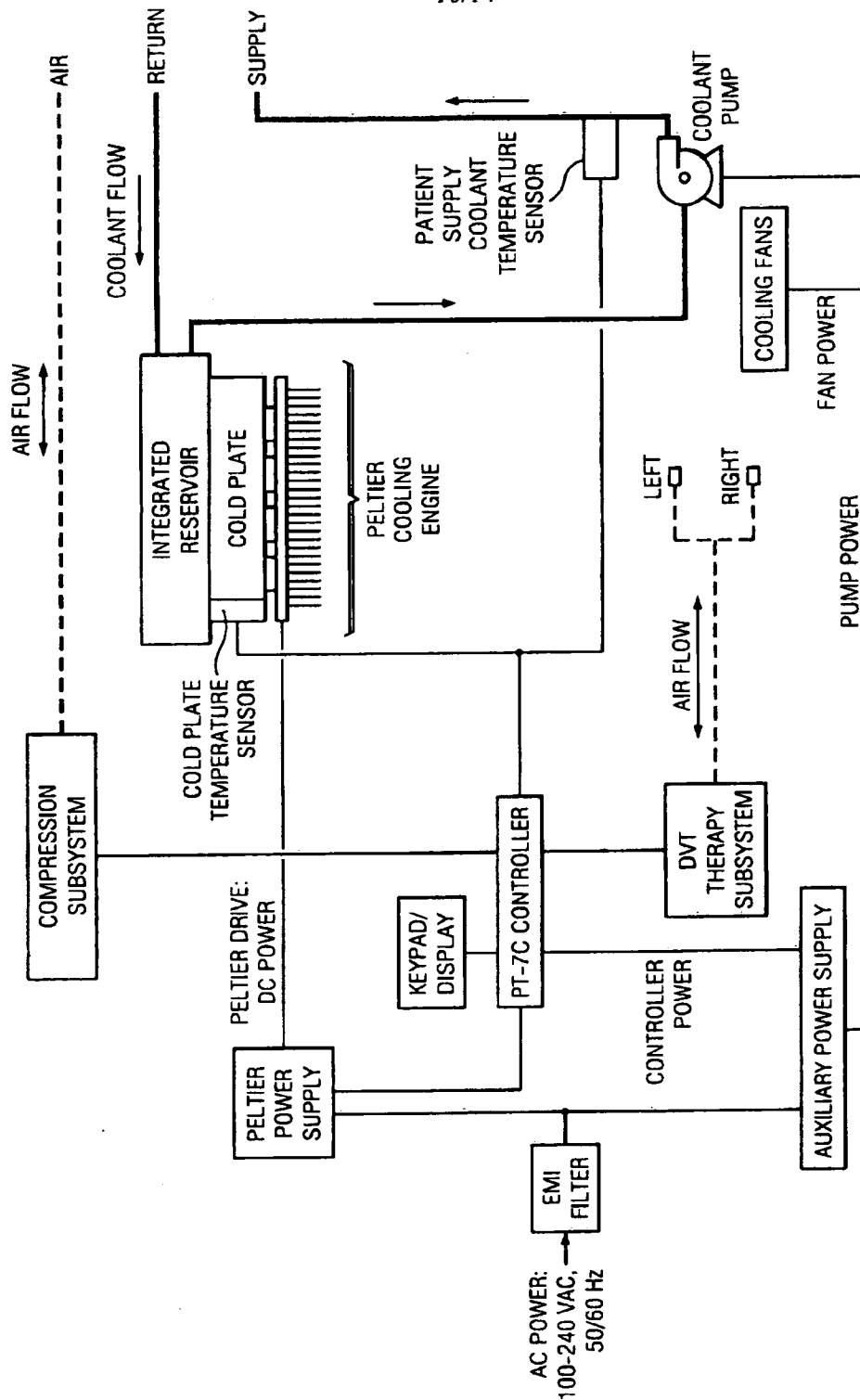
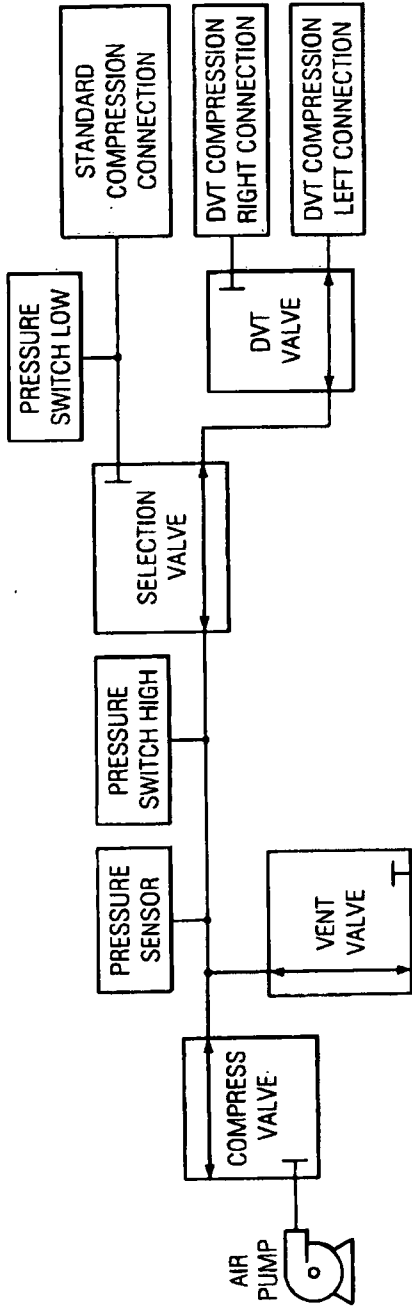

FIG. 16

11/14



MODE	STATE	AIR PUMP	COMPRESSION VALVE	SELECT VALVE	DVT VALVE	VENT VALVE
STANDARD	COMPRESS	ON	ON	ON	OFF	ON
	HOLD	OFF	OFF	ON	OFF	ON
	VENT	OFF	OFF	ON	OFF	OFF
DVT	COMPRESS LEFT	ON	ON	OFF	OFF	ON
	HOLD LEFT	OFF	OFF	OFF	OFF	ON
	VENT LEFT	OFF	OFF	OFF	OFF	OFF
	COMPRESS RIGHT	ON	ON	OFF	ON	ON
	HOLD RIGHT	OFF	OFF	OFF	ON	ON
	VENT RIGHT	OFF	OFF	OFF	ON	OFF

FIG. 17

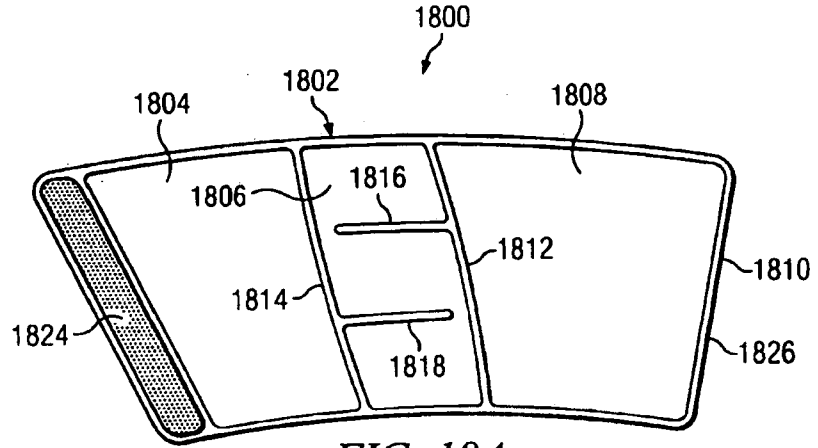

FIG. 18A

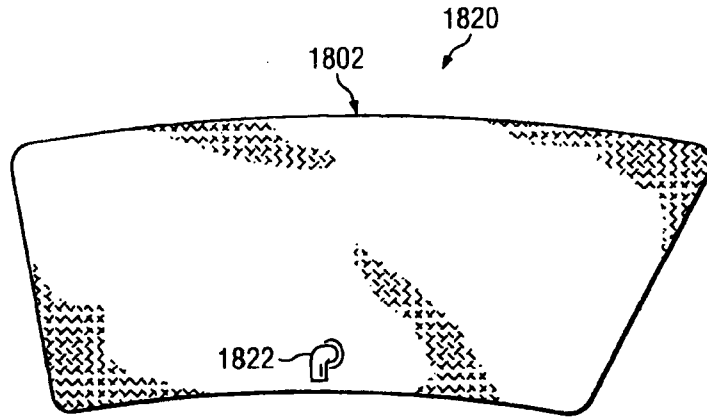

FIG. 18B

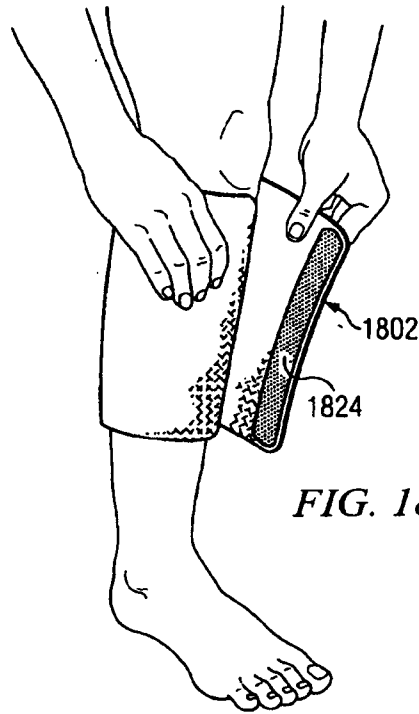

FIG. 18C

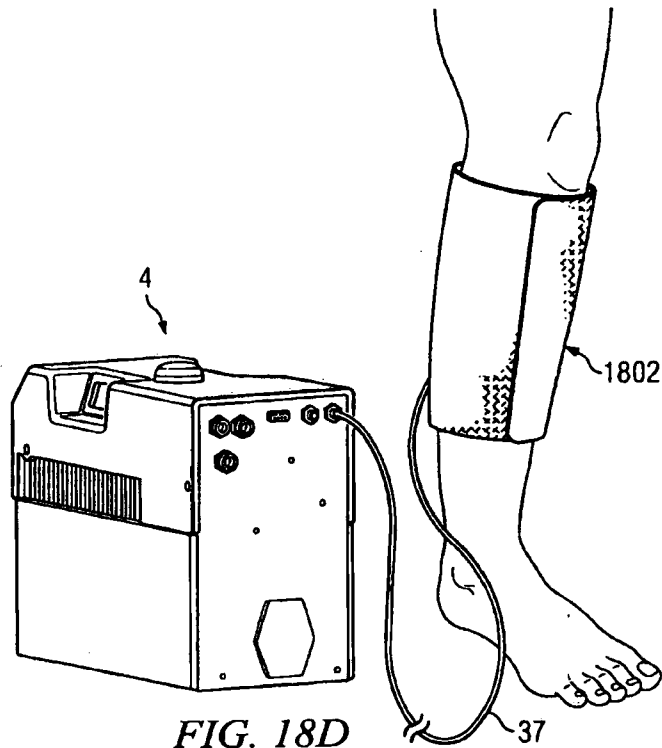
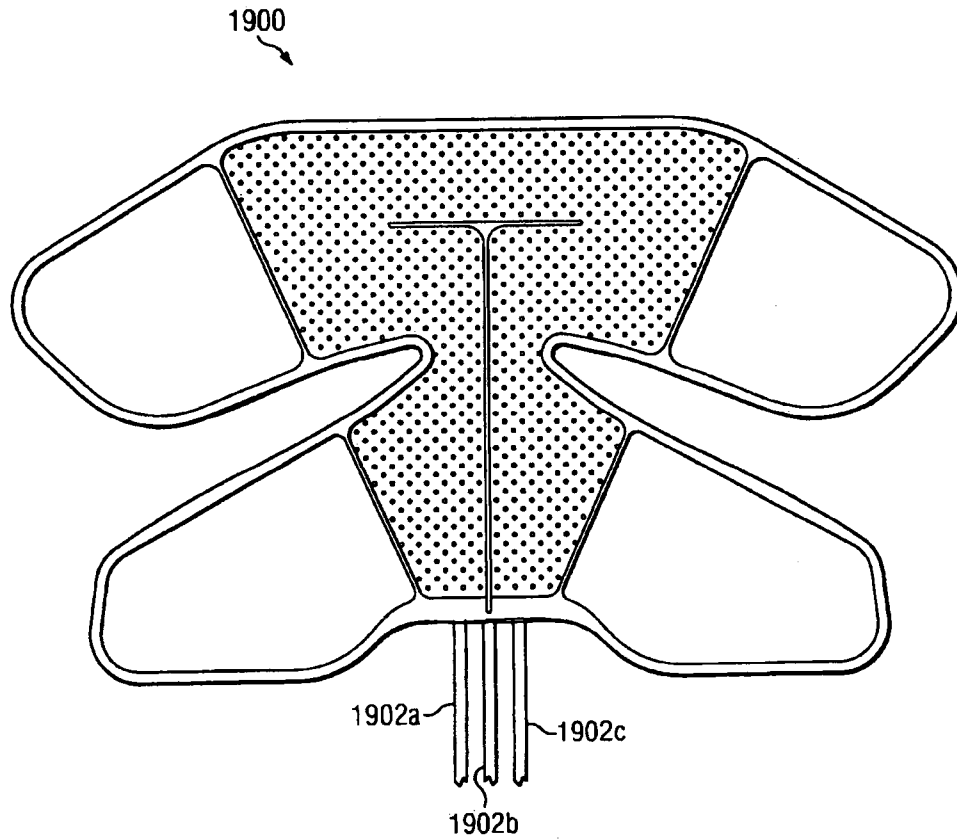

FIG. 18D



**FIG. 19**

