

(19) World Intellectual Property
Organization
International Bureau



(43) International Publication Date
16 September 2004 (16.09.2004)

PCT

(10) International Publication Number
WO 2004/079155 A2

- (51) International Patent Classification⁷: **E21B 33/05**,
21/10, 33/14
- (21) International Application Number:
PCT/US2004/006750
- (22) International Filing Date: 5 March 2004 (05.03.2004)
- (25) Filing Language: English
- (26) Publication Language: English
- (30) Priority Data:
60/452,192 5 March 2003 (05.03.2003) US
60/452,156 5 March 2003 (05.03.2003) US
10/389,483 14 March 2003 (14.03.2003) US
- (71) Applicant (for all designated States except US): **WEATHERFORD/LAMB INC.** [US/US]; 515 Post Oak Boulevard, Suite 600, Houston, TX 77027 (US).
- (72) Inventors; and
(75) Inventors/Applicants (for US only): **GIROUX, Richard, L.** [US/US]; 15618 Mustang Creek Circle, Cypress, TX 77429 (US). **SHAHIN, David** [US/US]; 9007 Upper-cove Cr., Houston, TX 77064 (US). **VUYK, Adrian, Jr.** [US/US]; 5003 Chantry Drive, Houston, TX 77084 (US). **THOMPSON, Gary** [US/US]; 21334 Park Tree Lane, Katy, TX 77450 (US).
- (74) Agents: **PATTERSON, William, B.** et al.; Moser, Patterson & Sheridan, L.L.P., 3040 Post Oak Boulevard, Suite 1500, Houston, TX 77056 (US).
- (81) Designated States (unless otherwise indicated, for every kind of national protection available): AE, AG, AL, AM, AT, AU, AZ, BA, BB, BG, BR, BW, BY, BZ, CA, CH, CN, CO, CR, CU, CZ, DE, DK, DM, DZ, EC, EE, EG, ES, FI, GB, GD, GE, GH, GM, HR, HU, ID, IL, IN, IS, JP, KE, KG, KP, KR, KZ, LC, LK, LR, LS, LT, LU, LV, MA, MD, MG, MK, MN, MW, MX, MZ, NA, NI, NO, NZ, OM, PG, PH, PL, PT, RO, RU, SC, SD, SE, SG, SK, SL, SY, TJ, TM,

[Continued on next page]

(54) Title: METHODS AND APPARATUS FOR HANDLING AND DRILLING WITH TUBULARS OR CASING

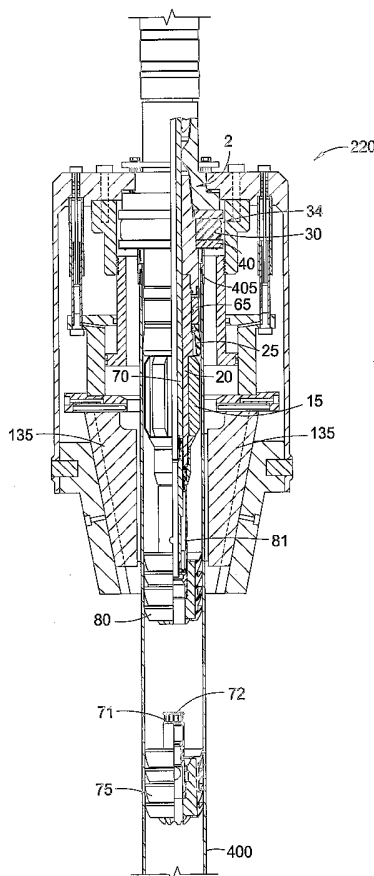

(57) Abstract: The present invention provides a method and apparatus for handling tubulars and drilling with tubulars such as casing into a formation. In one aspect of the invention, the apparatus comprises a circulating head and a cementing head operatively connectible to a gripping member. The circulating head is used to circulate drilling fluid while drilling with casing, and the cementing head is used to cement the casing string within the formation at a desired depth. The present invention also relates to methods and apparatus for isolating a tensile load from a drilling apparatus rotated by a top drive. In one aspect, the present invention provides a load isolator apparatus having an isolator body operatively connected to the top drive and a torque body at least partially disposed in the isolator body. In operation, the bearing assembly transfers the tensile load from the torque body to the isolator body.

WO 2004/079155 A2



TN, TR, TT, TZ, UA, UG, US, UZ, VC, VN, YU, ZA, ZM, ZW.

TR), OAPI (BF, BJ, CF, CG, CI, CM, GA, GN, GQ, GW, ML, MR, NE, SN, TD, TG).

(84) Designated States (*unless otherwise indicated, for every kind of regional protection available*): ARIPO (BW, GH, GM, KE, LS, MW, MZ, SD, SL, SZ, TZ, UG, ZM, ZW), Eurasian (AM, AZ, BY, KG, KZ, MD, RU, TJ, TM), European (AT, BE, BG, CH, CY, CZ, DE, DK, EE, ES, FI, FR, GB, GR, HU, IE, IT, LU, MC, NL, PL, PT, RO, SE, SI, SK,

Published:

— *without international search report and to be republished upon receipt of that report*

For two-letter codes and other abbreviations, refer to the "Guidance Notes on Codes and Abbreviations" appearing at the beginning of each regular issue of the PCT Gazette.

METHODS AND APPARATUS FOR HANDLING AND DRILLING WITH TUBULARS OR CASING

CROSS-REFERENCE TO RELATED APPLICATIONS

5 This application is a continuation-in-part of co-pending U.S. Patent Application Serial No. 10/389,483 filed March 14, 2003, which is herein incorporated by reference in its entirety. U.S. Patent Application Serial No. 10/389,483 is a continuation of U.S. Patent Application Serial No. 09/550,721 filed on April 17, 2000, now U.S. Patent No. 6,536,520, which is also herein incorporated by reference in its entirety.

10 This application claims benefit of U.S. Provisional Patent Application Serial No. 60/452,192 filed on March 5, 2003, which is herein incorporated by reference in its entirety. This application further claims benefit of U.S. Provisional Patent Application Serial No. 60/452,156 filed on March 5, 2003, which is herein incorporated by reference in its entirety.

15 BACKGROUND OF THE INVENTION

Field of the Invention

Embodiments of the present invention generally relate to handling tubulars and drilling into a formation to form a wellbore. More particularly, embodiments of the present invention relate to drilling with casing. Even more particularly, embodiments of
20 the present invention relate to drilling with casing and cementing the casing into the formation.

Description of the Related Art

In conventional well completion operations, a wellbore is formed to access hydrocarbon-bearing formations by the use of drilling. In drilling operations, a drilling
25 rig is supported by the subterranean formation and used to urge a drill string toward the formation. A rig floor of the drilling rig is the surface from which drilling strings with cutting structures, casing strings, and other supplies are lowered to form a subterranean wellbore lined with casing. A hole is formed in a portion of the rig floor above the desired location of the wellbore. The axis that runs through the center of the
30 hole formed in the rig floor is the well center.

Drilling is accomplished by utilizing a drill bit that is mounted on the end of a drill support member, commonly known as a drill string. To drill within the wellbore to a predetermined depth, the drill string is often rotated by a top drive or rotary table on the drilling rig. After drilling to a predetermined depth, the drill string and drill bit are removed and a section of casing is lowered into the wellbore.

Often, it is necessary to conduct a pipe handling operation to connect sections of casing to form a casing string which extends to the drilled depth. Pipe handling operations require the connection of casing sections to one another to line the wellbore with casing. To threadedly connect the casing strings, each casing section must be retrieved from its original location, typically on a rack beside the drilling platform, and suspended above well center so that each casing section is in line with the casing section previously disposed within the wellbore. The threaded connection is made up by a device that imparts torque to one casing section relative to the other, such as a power tong or a top drive. The casing string formed of the two or more casing sections is then lowered into the previously drilled wellbore.

It is common to employ more than one string of casing or section of casing in a wellbore. In this respect, the well is drilled to a first designated depth with a drill bit on a drill string. The drill string is removed. Sections of casing are connected to one another and lowered into the wellbore using the pipe handling operation described above to form a first string of casing longitudinally fixed in the drilled out portion of the wellbore. The first string of casing may then be cemented into place within the wellbore by a cementing operation. Next, the well is drilled to a second designated depth through the first casing string, and a second, smaller diameter casing string or string of casing comprising casing sections is hung off of the first string of casing or section of casing. A second cementing operation may be performed to set the second string of casing within the wellbore. This process is typically repeated with additional casing sections or casing strings until the well has been drilled to total depth. In this manner, wellbores are typically formed with two or more strings of casing.

It is known in the industry to use top drive systems to rotate the drill string to form the wellbore. The quill of the top drive is typically threadedly connected to an upper end of the drill pipe in order to transmit torque to the drill pipe.

As an alternative to the conventional method, drilling with casing is a method often used to place casing strings within the wellbore. This method involves attaching a cutting structure typically in the form of a drill bit to the lower end of the same string of casing which will line the wellbore. Drilling with casing is often the preferred method of well completion because only one run-in of the working string into the wellbore is necessary to form and line the wellbore for each casing string.

Drilling with casing is typically accomplished using a top drive powered by a motor because the top drive is capable of performing both functions of imparting torque to the casing string to make up the connection between casing strings during pipe handling operations and of drilling the casing string into the formation. A problem encountered with top drive systems is the potential for damage to the threads of the drill pipe or casing. Damage to the casing threads is problematic because the casing connections must remain fluid and pressure tight once the drilling operation has been completed.

Gripping heads have been developed for gripping casing to prevent damage to the threads. The top drive is connected to a gripping head, which may be an external gripping device such as a torque head or an internal gripping device such as a spear. A torque head is a type of gripping head which grips the casing by expanding a plurality of jaws or slips against an exterior surface of the casing. A spear is a gripping head which includes slips for gripping an interior surface of the casing.

Gripping heads generally have a top drive adapter for connection to a top drive quill. In this respect, torque may be transmitted to the casing with minimal damage to the threads of the quill.

The gripping head has a bore therethrough through which fluid may flow. The gripping head grippingly engages the casing string to serve as a load path to transmit the full torque applied from the top drive to the casing string.

The top drive and the gripping head, when the gripping head grippingly engages the casing, function as the means for rotating the casing string, means for providing a sealed fluid path through the casing string, and means for lowering the casing string into the wellbore. To function as the means for lowering the casing string into the

wellbore, the top drive is disposed on rails so that it is moveable axially in the plane substantially in line with well center. The rails also help the top drive impart torque to the casing string by keeping the top drive rotationally fixed.

Because the casing string is rotated by the top drive, the top drive also carries
5 the tensile load of the casing string. Therefore, the top drive connection may be a limiting factor in the load that is actually applied. For example, the connection between the top drive and the torque head may limit the tensile load supportable by the top drive. The problem is exacerbated when drilling with casing because a casing typically weighs more than a drill pipe. As a well is drilled deeper, the tensile load of a drilling
10 string of casing will increase faster than a drill string of drill pipe. Therefore, the drilling with casing operation may be prematurely stopped because the weight and drag of the casing drill string exceeded the tensile load rating of the top drive connection.

One proposed method of overcoming this problem is to increase the size of the threaded connection. While many drilling apparatus may be redesigned with a larger
15 size threaded connection to increase its tensile load capacity, it is very costly and inefficient to redesign or replace a top drive already existing on a rig.

There is a need, therefore, for an apparatus for increasing the drilling capacity of a top drive. There is a further need for an apparatus that isolates the tensile load from the top drive connection. There is also a need for an apparatus for isolating tensile
20 load that can be retrofitted with existing top drives.

During a typical drill pipe drilling operation, it is usually necessary to circulate drilling fluid while drilling the drill string into the formation to form a path within the formation through which the drill string may travel. Failure to circulate drilling fluid while drilling into the formation may cause the drill string to stick within the wellbore;
25 therefore, it is necessary for a fluid circulation path to exist through the drill string being drilled into the formation.

When running a typical casing string into a drilled wellbore, fluid is often circulated to prevent the casing string from sticking. Thus, a circulating tool is used within the casing string to circulate fluid through the casing string while running the
30 casing string into the drilled wellbore.

When it is desired to run the casing into the drilled out wellbore, the circulating tool is hooked up to the top drive and disposed within the casing string to allow circulation of the fluid. A check valve disposed in the bore of the circulating tool allows fluid flow from the surface of the well, through the casing string, and through the annular space between the outer diameter of the casing string and the formation, while preventing fluid from flowing back up through the check valve to the surface. The circulating tool further includes a packer or cup(s), usually an inflatable packer, disposed on its outer diameter. The packer is deployed to expand radially outward from the circulating tool to sealingly engage the inner diameter of the casing string. The packer and cup(s) seal the annular space between the outer diameter of the circulating tool and the inner diameter of the casing string; consequently, the packer isolates the inner diameter of the casing string below the packer to permit fluid under pressure to flow through the casing string and up through the annular space between the outer diameter of the casing string and the formation.

After the circulating tool is used to run the casing string to the desired depth within the formation, the casing string is often cemented into the wellbore at a certain depth before an additional casing string is hung off of the casing string so that the formation does not collapse onto the casing string due to lack of support. Furthermore, the casing string is often cemented into the formation once it reaches a certain depth to restrict fluid movement between formations. To cement the casing string within the wellbore, a cementing tool including a cementing head is inserted into the casing string to inject cement and other fluids downhole and to release cement plugs. The cementing head typically includes a plug releasing apparatus, which is incorporated into the cementing head above the wellbore. Plugs used during a cementing operation are held at the surface by the plug releasing apparatus. The typical cementing head also includes some mechanism which allows cement or other fluid to be diverted around the plugs until plug release is desired. Fluid is directed to bypass the plugs in some manner within the container until it is ready for release, at which time the fluid is directed to flow behind the plug and force it downhole.

The cementing head including an upper cement plug and a lower cement plug is used to cement the wellbore. The cement plugs typically define an elongated elastomeric body used to separate cement pumped into the wellbore from fluid ahead

of and behind the cement. The lower cement plug has radial wipers to contact and wipe the inside of the casing string as the plug travels down the casing string. The lower cement plug has a cylindrical bore therethrough to allow passage of cement. The cylindrical bore is typically closed to flow with a rupture or breakable disc or diaphragm.

5 The disc or diaphragm breaks or ruptures when the lower plug lands on a barrier to allow the passage of cement through the plug.

The lower cement plug is typically pumped ahead of the cement. After a sufficient volume of cement has been placed into the wellbore, an upper cement plug is deployed. Using drilling mud, cement, or other displacement fluid, the upper cement
10 plug is launched or pumped into the bore of the casing string. The upper cement plug is then pumped down the casing with displacement fluid, typically mud or water. As the upper cement plug travels downhole, it displaces the cement already in the bore of the casing to the annular area defined as the external casing diameter and the borehole. When the upper plug arrives at the barrier, it seats against the lower cement plug
15 already landed on the barrier, closing off the internal bore through the lower cement plug, thus stopping flow into the annular area.

To perform a cementing operation, the circulating tool must be retrieved from the casing string and set aside before the cementing tool can be installed on the casing string. The casing string is typically supported by a spider which grippingly engages
20 the outer diameter of the casing string on the rig floor at well center. Then, an entirely separate cementing tool is installed on the casing string by being threadedly connected or clamped onto an upper portion of the casing string to perform a cementing operation.

When using a separate cementing tool, extra time is necessary to rig down the gripping head and circulation tool and then rig up the cementing tool when it is desired
25 to cement the casing string into the formation. Extra time results in extra labor and money spent on the operation. Using a separate cementing tool to conduct a cementing operation also requires the hardware for the circulating tool as well as the additional hardware for an entirely separate cementing tool.

There is a need for an integrated apparatus which adapts the top drive for
30 gripping casing and includes circulating and cementing functions. There is a need for a means for gripping and rotating casing as the casing string is constructed (e.g., making

up or breaking out the threaded connection between casings), as well as a means for rotating the casing during the drilling operation. There is also a need to decrease the amount of time between the drilling into the formation and the cementing of the casing into the formation. There is a further need to decrease the amount of hardware
5 necessary at the drilling rig to drill into the formation and cement the casing into the formation.

SUMMARY OF THE INVENTION

Embodiments of the present invention include a method of forming a wellbore comprising operatively connecting a circulating head to a gripping mechanism;
10 grippingly and sealingly engaging a first tubular with the gripping mechanism; lowering the first tubular into a formation; operatively connecting a cementing plug to the gripping mechanism; grippingly and sealingly engaging a second tubular with the gripping mechanism; and lowering the second tubular into the formation. In another aspect, embodiments of the present invention include an apparatus for use in drilling
15 with casing comprising a tubular body having a fluid flow path therethrough; a circulating seal member and a cementing plug operatively connectible to the tubular body; and a gripping member for gripping the casing.

Other embodiments of the present invention provide an apparatus for compensating a gripping head comprising a mandrel operatively engaged to a gripping
20 head housing to form a torque-bearing connection; and at least one biasing member connected between the mandrel and the gripping head. In other embodiments, the present invention includes a method of cementing a casing within a formation, comprising providing a gripping mechanism connected to a cementing assembly; grippingly and sealingly engaging the casing with the gripping mechanism; moving the
25 casing to a depth within the formation; and cementing the casing within the formation using the cementing assembly without releasing the gripping and sealing engagement of the casing.

Embodiments of the present invention involve an apparatus which includes a tubular body with a bore therethrough. In one embodiment, a circulating head and a
30 cementing head are interchangeably and operatively connectible to a lower end of the tubular body. The circulating head circulates fluid through a casing string or casing

section. The cementing head circulates fluid to cement the casing string or casing section into the formation at a desired depth.

5 In one aspect, the cementing head comprises plugs which are releasable in response to longitudinal translation of a mandrel disposed within the bore of the tubular body. The plugs temporarily restrict fluid flow through the bore of the tubular body. In one embodiment, the slidable mandrel is moveable in response to fluid pressure (e.g., hydraulic or pneumatic).

10 In another aspect, embodiments of the present invention involve a method of cementing a wellbore using the apparatus comprising the tubular body having a circulating head interchangeable with a cementing head. In one embodiment, the method includes releasably and operatively attaching the circulating head to a lower end of the tubular body, grippingly and sealingly engaging a first casing with the apparatus, drilling the first casing to a first depth in a formation, removing the circulating head from the tubular body, releasably and operatively attaching a cementing head to 15 the lower end of the tubular body, grippingly and sealingly engaging a second casing with the apparatus, drilling the second casing to a second depth in the formation, using the cementing head to plug fluid flow through the second casing, and introducing a physically alterable bonding material into the apparatus.

20 Embodiments of the present invention allow a drilling with casing operation, including the drilling operation and the cementing operation, to be conducted by merely changing a lower portion of the apparatus. Embodiments of the present invention eliminate the need to use a separate cementing tool for the cementing operation, thus reducing the time and labor required for the operation. Consequently, the cost of the drilling with casing operation is reduced.

25 Embodiments of the present invention also generally relate to methods and apparatus for isolating a tensile load from a drilling apparatus rotated by a top drive. In one aspect, the present invention provides a load isolator apparatus having an isolator body operatively connected to the top drive and a torque body at least partially disposed in the isolator body. The torque body is position such that the torque body is 30 rotatable relative to the isolator body. The load isolator apparatus also includes a bearing assembly disposed between the isolator body and the torque body. The torque

body is operatively coupled to a tensile load of the drilling apparatus. In operation, the bearing assembly transfers the tensile load from the torque body to the isolator body.

In another aspect, the present invention provides a method of rotating a drilling apparatus having a tensile load using a top drive. The method includes operatively
5 connecting a load isolator apparatus to the top drive. Preferably, the load isolator apparatus includes a torque body disposed in an isolator body. Thereafter, the tensile load is transferred to the torque body, which, in turn, transfers the tensile load from the torque body to the isolator body. During rotation by the top drive, the torque body rotates relative to the isolator body.

10 In another aspect still, the present invention provides an elevator for use with a top drive. The elevator having an isolator body and a torque body at least partially disposed in the isolator body. The torque body defines a conical bore that houses one or more slip members. The elevator may further include one or more bearing members disposed between the torque body and the isolator body. Preferably, the torque body is
15 rotatable relative to the isolator body, and a tensile load acting on the torque body is transferred to the isolator body.

In yet another aspect, the present invention provides a top drive adapter for use with a top drive to rotate a drilling apparatus. The top drive adapter includes an isolator body and a torque body at least partially disposed in the isolator body. The torque
20 body includes a first coupling for connection with the top drive and a second coupling for connection with the drilling apparatus. The top drive adapter also includes one or more bearing members disposed between the torque body and the isolator body. Preferably, the torque body is rotatable relative to the isolator body, and a tensile load acting on the torque body is transferred to the isolator body.

25 In yet another aspect, the present invention provides an apparatus for controlling the fluid pressure supplied to the top drive. In one aspect, the apparatus includes a fluid supply line disposed between the pump and the top drive for supplying fluid to the top drive. A pressure relief valve is disposed on the fluid supply line and a fluid return line connects the pressure relief valve and the pump. When a fluid pressure reaches a
30 predetermined level, the pressure relief valve redirects the fluid back to the pump via the fluid return line.

BRIEF DESCRIPTION OF THE DRAWINGS

So that the manner in which the above recited features of the present invention can be understood in detail, a more particular description of the invention, briefly summarized above, may be had by reference to embodiments, some of which are
5 illustrated in the appended drawings. It is to be noted, however, that the appended drawings illustrate only typical embodiments of this invention and are therefore not to be considered limiting of its scope, for the invention may admit to other equally effective embodiments.

Figure 1 is a sectional view of a combination circulating/cementing tool of the
10 present invention. The right side of Figure 1 is cut away to show the parts of the tool.

Figure 2 is a schematic view of a system including the cementing/circulating tool of Figure 1, the system also including a top drive, cement line, and torque head.

Figure 3 is a sectional view of the circulating/cementing tool located within a torque head. The torque head is grippingly engaging casing disposed therein. The
15 circulating/cementing tool is used as a circulating tool while drilling the casing into the formation.

Figure 4 is a sectional view of the circulating/cementing tool located within a torque head. The torque head is grippingly engaging casing disposed therein. The circulating/cementing tool is used as a cementing tool. A lower cement plug is
20 launched within the casing.

Figure 5 shows a sectional view of the circulating/cementing tool used as a cementing tool within a torque head. The lower cement plug and an upper cement plug are launched.

Figure 6 is a sectional view of a circulating/cementing tool used with a spear as
25 a circulating tool while drilling with casing. A spear is located within the casing to grippingly engage the casing.

Figure 7 is a sectional view of a system for use with a compensator apparatus of the present invention, including a launching head, a compensator apparatus, a torque head, and a cement head.

Figure 8 is an enlarged view of the compensator apparatus.

Figure 9 is a sectional view illustrating the torque head in an extended downward position.

5 Figure 10 is a sectional view illustrating the torque head positioned prior to the threading operation.

Figure 11 is a sectional view illustrating the torque head positioned after the threading operation.

Figure 12 is a sectional view illustrating the torque head in an extended upward position.

10 Figure 13 is a sectional view illustrating a compensator apparatus positioned prior to the threading operation.

Figure 14 is a sectional view illustrating the torque head in an extended downward position.

15 Figure 15 is a sectional view illustrating the torque head in an extended upward position.

Figure 16 is an isometric view illustrating the compensator apparatus.

Figure 17 is a cross-sectional view of a top drive system having an elevator according to aspects of the present invention.

20 Figure 18 is an exploded cross-sectional view of the elevator shown in Figure 17.

Figure 19 is a cross-sectional view of a top drive isolator adapter according to aspects of the present invention.

Figure 20 is a view of a top drive system equipped with an apparatus for controlling the fluid pressure supplied to the top drive.

DETAILED DESCRIPTION OF THE PREFERRED EMBODIMENT

Figure 1 is a combination circulation/cementing tool 2 according to the present invention. The tool 2 has a tubular-shaped plug release mandrel 85 with a longitudinal bore therethrough. A sub 9 located at an upper portion of the tool 2 connects a lower
5 portion of a connector mandrel 11 to an upper portion of the tool 2. Threads 10 are located at an upper end of the sub 9 so that the tool 2 is capable of connection to other tools such as a top drive 200 (see Figure 2). Any other connection means known to those skilled in the art may be utilized in lieu of threads.

Connected to a lower end of the connector mandrel 11 by at least one sealing
10 member such as an o-ring is a tubular-shaped releasing body 43 with a longitudinal bore therethrough. The releasing body 43 has a plug release 45 located thereon. The releasing body 43 allows the shorting of the tool 2 to release the slips on either the torque head or spear (described below) in case of a hydraulic lock.

An upper end of a plug release body 44 is threadedly connected to a lower end
15 of the releasing body 43. The plug release body 44 is tubular-shaped with a longitudinal bore therethrough. The plug release body 44 has three hydraulic ports 50, 55, 60 located thereon to which hydraulic lines (not shown) may be connected, including an upper port 50, a middle port 55 located below the upper port 50, and a lower port 60 located below the middle port 55. The ports 50, 55, 60 are utilized in
20 various stages of the cementing operation, as described below.

A lower end of the plug release body 44 is threadedly connected to an upper end
of a landing plate mandrel 33, which is a tubular-shaped body with a longitudinal bore therethrough. The landing plate mandrel 33 is essentially a coupling with female
25 threads located on its upper end and lower end for threadedly connecting to male threads located on the ends of the portions of the tool 2 above and below the landing plate mandrel 33. Any other connection means known by those skilled in the art may be utilized other than threads. Disposed on the landing plate mandrel 33 is a landing plate 34, which includes an upper plate 35, a sealing member such as a cushion packer
30, and a lower plate 40. The upper plate 35 is located above the cushion packer 30, and the lower plate 40 is located below the cushion packer 30. The landing plate 34 rests on top of a casing coupling 305, 405 connected to a casing 300, 400 (see Figures

3 and 4). The casing 300, 400 may be a casing section or a casing string including two or more casing sections connected, preferably threadedly connected, to one another. Specifically, the lower plate 40 rests on the casing coupling 305, 405, while the cushion packer 30 is constructed of an elastomeric material to allow for slight (or larger) lateral movement of the tool 2 with respect to the casing when landing the landing plate 34 on the casing coupling 305, 405.

A tubular-shaped packer mandrel 20 with a longitudinal bore therethrough is connected, preferably threadedly connected, to the landing plate mandrel 33. An upper portion of the packer mandrel 20 has a sealing member, preferably a packer 65, disposed therearound. The packer 65 is preferably made of an elastomeric material so that it is selectively expandable to contact an inner diameter of the casing 300, 400. A cup packer 25 is disposed on the outer diameter of the packer mandrel 20 below the packer 65 to energize the packer 65. The packer 65 is activated to seal an annular area between the tool 2 and the casing 300, 400 when circulating fluid, thereby isolating the inner diameter of the casing 300, 400 so that fluid may be pumped under pressure through the casing 300, 400. In an alternate embodiment, an inflatable packer or a cup without a packing element may be used with the cementing tool 2. Below the cup packer 25, a centralizer 15 is disposed around the packer mandrel 20. The centralizer 15 is used to centralize the tool 2 within the casing 300, 400.

As shown in Figure 1, a cementing head 4 having a plug set is releasably connected to a lower end of the packer mandrel 20. The cementing head 4 comprises an upper plug chamber 81, which is tubular-shaped with a longitudinal bore therethrough. The cementing head 4 includes a lower cement plug 75 located below an upper cement plug 80. The cement plugs 75, 80 are releasably connected to one another by a collet 72 (see Figure 4) disposed on an upper portion of the lower cement plug 75. Each cement plug 75, 80 includes a flapper valve (not shown), which is initially biased in the open position so that fluid may flow through the cement plugs 75, 80. The lower cement plug 75 has a rupture disk (not shown) disposed thereon. The rupture disk initially blocks cement from traveling through the lower cement plug 75 as it travels downhole ahead of the cement. After the lower cement plug 75 lands on an internal diameter restriction such as a drill shoe, application of a predetermined pressure above the lower cement plug 75 by a cement volume causes the rupture disk

to burst so that cement is allowed through the cement plugs 75, 80, out through the casing 400, and up through the annular space between the casing 400 and the formation (not shown).

An upper portion of a plug release mandrel 85 is connected to an upper portion
5 of the plug release body 44. Disposed between a lower portion of the plug release mandrel 85 and a lower portion of the plug release body 44 is a slidable mandrel 70. The slidable mandrel 70 is a piston which is slidable within the cylinder formed by an annular space 42 between the plug release mandrel 85 and the plug release body 44. Shown in Figure 1, the slidable mandrel 70 is in an unactuated position, so that the
10 plugs 75, 80 are not launched. As fluid is introduced into the hydraulic ports 50, 55, 60, the slidable mandrel 70 slides upward relative to the plug release mandrel 85 and the plug release body 44. The upward movement of the slidable mandrel 70 launches the lower cement plug 75 and the upper cement plug 80, as described below.

Figure 2 is a schematic view of a system for using the circulation/cementing tool
15 2 according to the present invention. A top drive 200 is connected, preferably threadedly connected, to the tool 2. The top drive 200 is typically suspended from a draw works (not shown) with cable bails (not shown) and disposed on tracks (not shown) which allow longitudinal movement of the top drive 200, and thus, longitudinal movement of the connected tool 2. The top drive 200 performs the function of rotating
20 the tool 2 during the drilling operation; therefore, the tool 2 is rotatable relative to the top drive 200. The tool 2, however, is preferably axially fixed relative to the top drive 200 so that the draw works (not shown) may be used to lift or lower the top drive 200 longitudinally, thus lifting or lowering the tool 2 therewith.

A cement line 205 extends through a port 215 running through the tool 2. A
25 physically alterable bonding material, preferably a setting fluid such as cement, is selectively introduced through the cement line 205 and into the tool 2 through selective operation of a check valve 210. When it is desired to introduce cement into the tool 2, such as during the cementing operation, the check valve 210 is manipulated into an open position. When it is desired to prevent cement introduction into the tool 2, such as
30 during the drilling operation when circulation fluid rather than cement is circulated through the tool 2, the check valve 210 is closed. Placing the cement line 205 below

the top drive 200 allows the cement to bypass the top drive 200 during the cementing operation, thus preventing possible damage to the top drive 200.

A torque head 220 is rigidly connected to the tool 2. The torque head 220 is used to grippingly and sealingly engage the casing 300, 400 (see Figures 3 and 4). In the alternative, a spear 66 may be used to grippingly and sealingly engage the casing 300, 400, as shown in Figure 6 and described below. The torque head 220 imparts torque to the casing 300, 400 from the top drive 200 by grippingly engaging the casing 300, 400. The torque head 220 rotates with the tool 2 relative to the top drive 200.

The tool 2 runs through the torque head 220. A lower portion of the tool 2 is shown located below the torque head 220. The solid lines indicate the circulating/cementing tool 2 with a circulating head 3 placed thereon. The dotted lines indicate the tool 2 with the cementing head 4 placed thereon. When drilling with the casing 300, the circulating head 3 is placed at the lower portion of the tool 2 to circulate drilling fluid. When a cementing operation is to be conducted, the cementing head 4 is placed at the lower portion of the tool 2. The circulating head 3 may be connected, preferably threadedly connected, to a lower portion of the packer mandrel 20, so that to replace the circulating head 3 with the cementing head 4, the circulating head 3 must merely be unscrewed. The cementing head 4 may then be threadedly connected to the packer mandrel 20. In the same way, the cementing head 4 may be unscrewed, then the circulating head 3 threaded onto the packer mandrel 20, depending upon the function which the tool 2 is to perform.

Figure 3 shows a lower portion of the tool 2 rigidly connected to the torque head 220, preferably by one or more bolts 115. As shown in Figure 3, the circulating head 3 is connected to the lower portion of the tool 2 so that the casing 300 may be drilled into the formation while the tool 2 dispenses circulating fluid. The casing 300 is disposed between the torque head 220 and the tool 2. The casing 300, which typically has male threads disposed at its upper end, is connected, preferably threadedly connected, to the casing coupling 305 by female threads located at both ends of the casing coupling 305. The female threads of the casing coupling 305 are used to mate the casing 300 with another casing (not shown) to line the wellbore with casing. The lower plate 40 of

the landing plate 34 is located directly above the upper female thread of the casing coupling 305 during the drilling operation, as shown in Figure 3.

Any gripping mechanism capable of grippingly and sealingly engaging an outer or inner diameter of the casing 300 is suitable for use with the tool 2 of the present invention. The torque head 220 shown in Figure 3 may be used as the gripping mechanism to grip the outer diameter of the casing 300, while the spear 66 shown in Figure 6 may also be used instead of the torque head 220 to grip the inner diameter of the casing 300.

As shown in Figure 3, the torque head 220 has a central bore 165 therethrough in which the casing 300 and the tool 2 are disposed. The torque head 220 includes a tubular-shaped housing 105 through which the bolts 115 connect the torque head 220 to the tool 2. One or more dowels 130 rigidly connect an inner diameter of a bowl 125 having an inclined inner wall to the housing 105. One or more gripping members 135, preferably slips, are disposed within the bowl 125 to grippingly engage an outer diameter of the casing 300. The inner sides of the slips 135 may carry teeth formed on hard metal dies for engaging the casing 300. The inclined surfaces of the slips 135 and the bowl 125 allow the slips 135 to move vertically and radially inward relative to the bowl 125 to grippingly engage the casing 300.

An annular ram drive 170 is connected to a plate 145 disposed above the slips 135 and serves as means for moving the slips 135 along the incline of the bowl 125 so that the slips 135 grippingly engage the outer diameter of the casing 300. One or more actuators 121, preferably hydraulic actuators, for the slips 135 are connected to an upper portion of the annular ram drive 170. One or more springs 62 are held initially in a biased position by the actuator 121 when the slips 135 are unactuated. When it is desired to grip the casing 300 within the torque head 220, a hydraulic line (not shown) may be hooked up to the actuator 121 to force the one or more springs 62 to compress, thus actuating the slips 135 of the torque head 220 so that the slips 135 move along the inclined surface of the bowl 125 and grippingly engage the outer diameter of the casing 300.

Figure 6 shows the spear 66 instead of the torque head 220 used as the gripping mechanism with the tool 2. The spear 66 includes a tubular body 13 with a longitudinal

bore therethrough. One or more slips 12 are disposed on an outer diameter of the tubular body 13 above the circulating head 3 or cementing head 4 (the circulating head 3 is shown with the spear 66 in Figure 6). When actuated, the slips 12 are used to grippingly and sealingly engage the inner diameter of a casing (not shown). The slips
5 12 may be actuable by hydraulic or pneumatic force. An external hydraulic or pneumatic source may be connected to the spear 66 to actuate the slips 12. The hydraulic or pneumatic force may be created by fluid behind a piston within a cylinder. When the slips 12 are unactuated, the casing is moveable axially and rotationally relative to the spear 66.

10 The cementing/circulating tool 2 is disposed within the spear 66 and is rigidly fixed therein. The tool 2 has a shoulder 26 disposed around the outer diameter of the tubular body 13. When the tool 2 and spear 66 are inserted into the casing, the shoulder rests upon the casing in the same manner as the landing plate 34 rests on the casing, as described in relation to Figures 1-5.

15 In the operation of the spear 66 with the tool 2, the top drive (not shown), which is connected to the upper end of the sub 9, is lowered along with the spear 66 and tool 2 so that a lower portion of the spear 66 and tool 2 are located within the casing. The slips 12 are actuated to grippingly and sealingly engage the inner diameter of the casing. The only substantial difference in operation between the torque head 220 and
20 the spear 66 involves the gripping of the casing (the spear 66 grips the inner diameter of the casing rather than the outer diameter of the casing); therefore, the remainder of the operation of the spear 66 with the tool 2 and casing is the same as described below in relation to Figures 1-5.

In operation, referring to Figures 1-5, an upper end of the circulating head 3 is
25 threaded onto a lower end of the packer mandrel 20 so that the assembly shown by the solid lines in Figure 2 is formed. The casing 300 has an earth removal member, preferably a cutting structure such as a drill shoe or drill bit, operatively connected to its lower end for use in drilling with casing. The casing 300 may be initially located on a rack (not shown) or pickup/lay down assembly (not shown) outside of a drilling rig (not
30 shown). The casing 300 may be transported, in one embodiment by a single joint elevator on cable bails, to a location substantially center of a well above a hole (not

shown) in a rig floor (not shown) of the drilling rig. The single joint elevator is used to grippingly engage the casing 300 so that the casing 300 is longitudinally fixed below the tool 2 and the torque head 220. The top drive 200, tool 2, and torque head 220 are lowered toward the casing 300 by the draw works.

5 As the torque head 220 is lowered, the casing 300 is located within the torque head 220 between the torque head 220 and the tool 2, as shown in Figure 3. The torque head 220 is lowered until the lower plate 40 of the landing plate 34 hits the upper end of the casing coupling 305, as depicted in Figure 3. Fluid is then introduced through the actuator 121 by the fluid hose (not shown). The actuator 121 forces the
10 springs 62 to contract from the biased position, thus forcing the slips 135 down the incline of the bowl 125. The slips 135 are thereby actuated to grippingly and sealingly engage the casing 300.

 The tool 2 is then activated to seal an annular space between an outer diameter of the packer mandrel 20 and an inner diameter of the casing 300 to prevent fluid flow
15 through the annular space while circulating fluid. The cup packer 25 energizes the packer 65, and the packer 65 expands to sealingly engage the inner diameter of the casing 300. Figure 3 shows the torque head 220 grippingly engaging the casing 300 and the tool 2 sealingly engaging the casing 300.

 In this position, an assembly 402 including the tool 2, torque head 220, and
20 casing 300 is ready to lower the casing 300 into the formation to form the wellbore (not shown). The top drive 200 (see Figure 2) rotates the assembly 402 relative to the top drive 200. At the same time, drilling fluid is circulated through the top drive 200, through the tool 2, and out through the casing 300. The fluid flows around the lower end of the casing 300 and up through an annular space between the outer diameter of
25 the casing 300 and the formation. Drilling fluid is circulated while drilling into the formation to form a path for the casing 300 in the formation and to clear the inner diameter of the casing 300 of mud and other substances to facilitate the drilling process.

 Once the casing 300 is drilled to the desired depth within the formation, a spider
30 (not shown) is actuated to grippingly engage the outer diameter of an upper portion of the casing 300, so that the casing 300 is prevented from moving further downward into

the wellbore. The slips 135 of the torque head 220 are then released from gripping engagement with the outer diameter of the casing 300, and the packer 65 of the tool 2 is released from sealing engagement with the inner diameter of the casing 300. An interlock system such as the system disclosed in U.S. Patent Application Publication
5 Number 2002/0170720, filed by Haugen on May 17, 2001, which is herein incorporated by reference in its entirety, may be used with the present invention to ensure that either the spider or the torque head 220 is grippingly engaging the casing 300 at all times. The casing 300 is left within the wellbore while the torque head 220 and the rigidly connected tool 2 are lifted from the wellbore by the draw works.

10 Additional casings may then be drilled into the formation to form a cased wellbore of a desired depth. The additional casings typically have male threads disposed at their upper and lower ends (rather than a cutting structure disposed at the lower end, such as in the casing 300), so that a lower end of a coupling such as the casing coupling 305 with female threads disposed at both ends is threaded onto the
15 male threads on the upper end of each casing.

Each additional casing may be transported to well center from the rack or pickup/lay down machine and inserted into the torque head 220 between the torque head 220 and the tool 2, as described above in relation to casing 300. The slips 135 of the torque head 220 are actuated into gripping engagement with the outer diameter of
20 the additional casing, and the packer 65 of the tool 2 is deployed into sealing engagement with the inner diameter of the additional casing.

The additional casing is lowered by the draw works toward the casing 300 already disposed within the wellbore. The top drive 200 is then actuated to rotate the additional casing relative to the casing 300. The casing 300 is rotationally and axially
25 fixed at this time due to the gripping engagement of the spider. A threaded connection is made up between the male threads of the additional casing string and the female threads of the casing coupling 305 by the rotational forces imparted by the top drive 200. Next, the casing comprising the casing 300 and the additional casing is released from the spider and lowered (possibly while rotating) into the formation as described
30 above in relation to drilling the casing 300 into the formation. This process is repeated with any number of additional casings.

After a certain amount of additional casings are coupled to one another and lowered into the formation, a cementing operation must often be performed to prevent the formation from collapsing into the casing. When it is desired to drill the last casing into the formation before cementing the annular space between the casing and the formation to form a cased wellbore, the torque head 220 and the tool 2 are removed from the wellbore, and the second-to-last casing before the cementing operation is left within the wellbore suspended by the spider.

Referring to Figure 2, the circulating head 3 shown by the solid lines is unthreaded from the packer mandrel 20. The cementing head 4, which is shown by the dotted lines, is then threaded onto the lower end of the packer mandrel 20. The last casing 400 (see Figure 4) may be picked up from the rack or pickup/lay down machine and transported to the well center. The torque head 220 and the tool 2 are then lowered by the draw works so that the casing 400 is inserted into the torque head 220 between the torque head 220 and the tool 2.

Once the torque head 220 and the tool 2 are lowered onto the casing 400 so that the lower plate 40 of the tool 2 is touching the upper end of the casing coupling 405, the slips 135 are actuated to grippingly engage the outer diameter of the casing 400, as described above in relation to the casing 300. Moreover, the packer 65 of the tool 2 is deployed to sealingly engage the inner diameter of the casing 400 as described above in relation to the casing 300.

After the packer 65 and slips 135 engage the casing 400, the casing 400 is rotationally and axially fixed within the torque head 220. The casing previously disposed within the wellbore is rotationally and axially fixed within the spider (not shown) at well center. The draw works is lowered so that the casing 400 rests on the casing previously disposed within the wellbore, and the threadable connection between the casings is made up by rotation imparted upon the casing 400 by the top drive 200.

The spider is then released from gripping engagement with the additional casing previously disposed in the wellbore, so that the casing 400 with the additional casing connected thereto is moveable axially and rotationally within the wellbore. Circulating fluid is introduced into the top drive in the same manner as described above, and the fluid travels through the tool 2, through the casing 400, through the additional casings,

through the casing 300 with the cutting structure attached thereto, and up through the annular area between the casing 400, 300 and the formation. At this point, the flapper valves (not shown) of the cement plugs 75, 80 are biased in the open position by the slidable mandrel 70, so that fluid is flowable through the cement plugs 75, 80 to circulate around the casing 400, 300. The collet fingers 71 (shown in Figure 4) of the collet 72, which is located on the lower cement plug 75, are initially engaging the upper cement plug 80 to hold the two cement plugs 75, 80 together.

While the drilling fluid is introduced into the top drive 200, drilling into the formation to form the wellbore is accomplished by the top drive 200 rotating the torque head 220, tool 2, and casing 400, 300, which are all substantially axially and rotationally fixed relative to one another. Simultaneously, the draw works lowers the top drive 200, torque head 220, tool 2, and casing 400, 300 into the formation. After the casing 400, 300 has been drilled to the desired depth within the formation, the rotational and axial movement of the casing 400, 300 is halted. Also, the drilling fluid is no longer introduced into the top drive 200.

After the drilling operation is halted, the cementing operation begins. The lower cement plug 75 is launched before cement is introduced into the casing string 400, 300 to clean out the inner diameter of the casing string 400, 300. To launch the lower cement plug 75, hydraulic fluid is introduced through a hydraulic hose (not shown) into the lower port 60 (see Figures 1 and 4). Fluid introduced behind the slidable mandrel 70 forces the slidable mandrel 70 up with respect to the plug release mandrel 85 and the plug release body 44. The slidable mandrel 70 moves upward through the annular space 42 to the upper port 55. As the slidable mandrel 70 moves up, the flapper valve of the lower cement plug 75 closes. The collet fingers 71 of the collet 72 are released from engagement with the upper cement plug 80 so that the lower cement plug 75 is axially moveable with respect to the upper cement plug 80.

Cement is then introduced through the cement line 205 (see Figure 2) into the tool 2. The cement flows through the upper cement plug 80, but is prevented from flowing through the lower cement plug 75 because the flapper valve of the lower cement plug 75 is in the closed position. A volume of cement necessary to fill the annular space between the casing 400, 300 and the formation is introduced through the

upper cement plug 80 and behind the lower cement plug 75 to force the lower cement plug 75 downward within the casing string 400, 300 until the lower cement plug 75 is hindered from further downward movement by a drill shoe or drill bit (not shown) disposed at the lower end of the casing 400, 300. Figure 4 shows the lower cement
5 plug 75 launched within the casing 400, 300. Cement is located between the lower cement plug 75 and the upper cement plug 80.

After the desired volume of cement has been introduced behind the lower cement plug 75, the upper cement plug 80 is launched. To launch the upper cement plug 80, fluid is introduced through the hydraulic hose (not shown), into the middle port
10 55, and behind the slidable mandrel 70. The slidable mandrel 70 moves further upward within the annular space 42 to the upper port 50, causing the connection (preferably a collet) of the upper cement plug 80 to the tool 2 to release.

As the upper cement plug 80 travels downward within the casing string 400, 300, the flapper valve within the upper cement plug 80 closes. Fluid behind the upper
15 cement plug 80 forces the upper cement plug 80 downward within the casing 400, 300. The upper cement plug 80 continues downward within the casing 400, 300 until it is stopped from further downward movement by the cement between the cement plugs 80, 75. Figure 5 shows the upper cement plug 80 launched behind the lower cement plug 75.

20 The increasing pressure produced when the lower cement plug 75 lands on the drill shoe and stops moving causes the rupture disk (not shown) to burst so that the cement between the cement plugs 75, 80 is free to travel through the lower cement plug 75, through a lower portion of the inner diameter of the casing 400, 300, and up through the annular space between the outer diameter of the casing 400, 300 and the
25 wellbore formed in the formation. The cement fills the annular space between the outer diameter of the casing 400, 300 and the wellbore formed in the formation to form a cased wellbore. Fluid flow through the cement line 205 is stopped by closing the check valve 210, and the cement is allowed to cure at hydrostatic pressure.

At the end of the cementing operation, the slidable mandrel 70 may be returned
30 to its original location directly above the lower port 60 for further operations by introducing fluid through the upper port 50. Fluid flows through the upper port 50, into

the annular space 42, and in front of the slidable mandrel 70 to move the slidable mandrel 70 downward. In an alternate embodiment, the apparatus and method of the present invention are equally effective when only a single cement plug is launched such as the single direction top plug shown and described in the U.S. Patent Application
5 Number 10/767,322 filed by applicants on January 29, 2004, which is herein incorporated by reference in its entirety.

The slips 135 are next unactuated so that they are released from gripping engagement with the outer diameter of the casing 400, 300, and the packer 65 is released from sealing engagement with the inner diameter of the casing 400, 300. The
10 cement in the annular space between the casing 400, 300 and the formation holds the casing 400, 300 in place within the wellbore while the torque head 220 and the tool 2 are pulled upward out of the wellbore by the draw works. A circulating head may be threaded onto the packer mandrel 20 if further drilling with casing operations are desired. When performing further drilling with casing, the cement plugs 75, 80 and the
15 drill shoe or other earth removal member at the lower end of the casing 300 may be drilled through by an earth removal member such as a cutting structure operatively connected to a lower end of a subsequent casing when the subsequent casing with the cutting structure attached thereto is inserted through the inner diameter of the casing 400, 300. In the alternative, the cement plugs 75, 80 and the earth removal member
20 may be retrieved from the wellbore and a subsequent casing drilled through the casing 300, 400. The process outlined above may be repeated to drill the subsequent casings into the formation and cement the drilled casings into the wellbore.

In the above-described embodiments, the cementing/circulating tool 2 may include several subs/mandrels connected together, as described above. In the
25 alternative, the cementing/circulating tool 2 may include one continuous tubular body.

In the above-described process, the slidable mandrel 70 is slidable due to hydraulic force, but it is also within the scope of the invention for the slidable mandrel 70 to be moveable upward by pneumatic force, electronic means, threadable connections between the slidable mandrel 70 and the adjacent mandrels 44 and 6, a
30 vacuum system, or any other suitable mechanism.

Additionally, although the above description of embodiments shown in Figures 1-6 relate to drilling while rotating the entire casing 300, 400, only a portion of the casing 300, 400 such as the drill bit may be rotated by a mud motor, for example, while lowering the casing 300, 400 into the formation to form the wellbore. It is also contemplated that the casing 300, 400 may merely be pushed or lowered into the formation while circulating drilling fluid therethrough without rotating any portion of the casing to form the wellbore.

In another aspect of this invention, a joint compensator is disclosed. Generally, a joint compensator is used for compensating the weight of a first joint and at least one subsequent joint, whereby the first joint is supported above the at least one subsequent joint. Typically, the joint compensator comprises a body interconnectible between the first joint and a moving apparatus for moving the first joint. The body includes a supporting apparatus for supporting the first joint above the at least one subsequent joint and for providing support of the first joint as it moves with respect to the at least one subsequent joint. The supporting apparatus compensates for weight of the first joint as it moves. The supporting apparatus includes a piston movably mounted in a hollow cylinder with an amount of gas above the piston and an amount of gas below the piston. An exemplary joint compensator is described in U.S. Patent Number 5,850,877, issued to Albright et al. on December 22, 1998, which is herein incorporated by reference in its entirety.

Figure 7 is a sectional view of the system for use with the present invention, including a launching head 450, a compensator apparatus 500, the torque head 220 and the cementing head 4. The system illustrated in Figure 7 operates in a similar manner as described above. The launching head 450 is used to actuate the cementing head 4 during the cementing operation.

During drilling and circulation of the casing, the cement plugs are not located on the end of the circulation tool. The launching head 450 permits fluid to pass through during the circulating and drilling operations. A one-way valve such as a check valve 455, preferably located at a lower end of the circulation tool, prevents fluid flow in the opposite direction. Fluid flows through a bypass passageway 470 formed in an assembly housing 485. The bypass passageway 470 allows the fluid to be

communicated through the launching head 450 without affecting upper and lower darts 465, 460. As illustrated in Figure 7, an upper dropper 475 holds the upper dart 465 in place and the lower dart 460 is held in place by a lower dropper 480. The upper and lower droppers 475, 480 may be manually or remotely operated.

5 As previously described, the upper and lower cement plugs 80, 75 are used during the cementing operation. To release the lower cement plug 75, the lower dropper 480 is actuated, thereby removing a releasable connection such as a pin (not shown) that holds the lower dart 460 in place. Subsequently, fluid pumped through the launching head 450 causes the lower dart 460 to move axially downward through the
10 compensator apparatus 500 and the torque head 220 until it contacts the lower cement plug 75. In turn, the cement plug 75 is released, thereby initiating the cementing operation.

After the cement has been pumped through the system as described above, the upper dart 465 is released in a similar manner as the lower dart 460. Particularly, the
15 upper dropper 475 releases the upper dart 465 to move through the system until it contacts the upper cement plug 80. Thereafter, the upper cement plug 80 is released to complete the cementing operation. In this manner, the torque head 220 is integrated with the launching head 450 and the cementing head 4 (as well as the circulating head 3) of the circulating/cementing tool 2, thereby providing a system capable of running
20 casing as well as permitting a circulating (fill-up) and a cementing operation. The torque head 220 integrated with the launching head 450 and the circulating/cementing tool 2 also allows reciprocation (axial movement) of casing in the well.

In an alternate embodiment, other devices including but not limited to balls or free falling darts having no fins to pump them down may be used to launch both the
25 upper and lower cement plugs 75, 80. Additionally, only a single top plug may be utilized with the present invention such as the single direction top plug shown and described in U.S. Patent Application Number 10/767,322 filed by applicants on January 29, 2004, which was above incorporated by reference.

Figure 8 is an enlarged view of the compensator apparatus 500. Generally, the
30 compensator apparatus 500 compensates for the weight of a casing 585, which may include a casing section or a casing string including two or more casing sections

connected (preferably threadedly connected) to one another, and permits the torque head 220 to move axially during the operation. The compensator apparatus 500 includes an apparatus housing 545 that connects the compensator apparatus 500 to the launching head 450. The apparatus housing 545 includes a housing surface 580.

5 The compensator apparatus 500 further includes a spline mandrel 555 operatively attached to the interior portion of the apparatus housing 545. The spline mandrel 555 includes a mandrel surface 565.

 The spline mandrel 555 and a cylinder 505 define an upper chamber 525. An upper port 510 formed in the housing 545 permits fluid communication in and out of the
10 upper chamber 525. As shown in Figure 8, the cylinder 505 is axially movable within the compensator apparatus 500. The cylinder 505 includes an upper surface 575 and a lower surface 560. Additionally, the cylinder 505 includes a cylinder face 595 that is operatively attached to the spline mandrel 555 to form a torque connection, thereby allowing torque from the top drive 200 (shown in Figure 2) to be transmitted through the
15 compensator apparatus 500 to the torque head 220. The torque connection is maintained throughout the axial movement of the cylinder 505. In other words, a torque may be transmitted from the top drive 200 to the torque head 220 throughout the operation. The torque connection may be constructed and arranged from a spline arrangement, a key and groove arrangement, or any other form of torque connection
20 known in the art.

 A lower chamber 530 is formed between the spline mandrel 555 and the cylinder 505. One or more sealing members 540 disposed between the spline mandrel 555 and the cylinder 505 provide a fluid tight relationship therebetween. The lower chamber 530 is in fluid communication with the upper chamber 525 through a valve assembly
25 520. Fluid flows in and out of the lower chamber 530 through a lower port 515 formed in the housing 545. The lower port 515 and upper port 510 are connected to the valve assembly 520 to form a circuit. The valve assembly 520 may be located near the rig floor and may be manually or remotely operated to adjust the fluid pressure in the upper and lower chambers 525, 530, thereby extending or retracting the cylinder 505.

30 The cylinder 505 is mechanically attached to the housing 105 of the torque head 220. As shown in Figure 8, one or more bolts 535 may be used to secure the housing

105 to the compensator apparatus 500. Additionally, one or more biasing members 572 are disposed on the one or more bolts 535. Generally, the one or more biasing members 572 compensate for misalignment between the compensating apparatus 500 and the torque head 220. As shown on Figure 8, the biasing members 572 comprises
5 belleville washers; however, other forms of biasing members 572 may be employed so long as they are capable of compensating for misalignment between the compensating apparatus 500 and the torque head 220.

The compensator apparatus 500 is useful in making up and breaking out threadable connections between tubulars, including threadable connections between
10 casing sections. The compensator apparatus 500 allows axial movement upward and downward of the torque head 220 and casing 585 relative to the top drive 200.

Figure 9 is a sectional view illustrating the torque head 220 in an extended downward position. As shown, the cylinder 505 and the torque head 220 have moved axially downward relative to the apparatus housing 545 and spline mandrel 555. Fluid
15 from the upper chamber 525 is communicated through the valve assembly 520 (shown in Figure 8) into the lower chamber 530, thereby urging the cylinder 505 axially downward until the cylinder lower surface 560 contacts the mandrel surface 565. In this position, the torque head 220 is fully extended axially downward to permit the torque head 220 to pick up the casing 585. Thereafter, the torque head 220, casing
20 585, and cylinder 505 move axially upward as shown in Figure 10.

Figure 10 is a sectional view illustrating the torque head 220 positioned prior to the threading operation. As shown, the cylinder 505, the torque head 220, and the casing 585 have moved axially upward relative to the apparatus housing 545 and spline mandrel 555. Particularly, fluid from the lower chamber 530 is communicated through
25 the valve assembly 520 (shown in Figure 8) into the upper chamber 525, thereby urging the cylinder 505 axially upward. In this position, the torque head 220, and casing 585 may move axially downward relative to the top drive during the threading operation.

Figure 11 is a sectional view illustrating the torque head 220 positioned after the threading operation. As shown, the cylinder 505, the torque head 220, and the casing
30 585 have moved axially downward relative to the apparatus housing 545 and spline mandrel 555. Fluid from the upper chamber 525 is communicated through the valve

assembly 520 into the lower chamber 530, thereby urging the cylinder 505 axially downward relative to the spline mandrel 555. In other words, as the casing 585 is threaded into the lower casing (not shown) any axial movement, for example due to the threading engagement, is compensated by the movement of the torque head 220 and the cylinder 505, thereby minimizing tension created during the threading operation between the torque head 220 and the top drive 200 (shown in Figure 2). In a similar manner, the breaking out process may be accomplished by reversing the order of operation as previously discussed relating to Figures 9-11.

Furthermore, the torque head 220 is positioned to circulate fluid through the entire string of casing (not shown). In this position, the torque head 220 may also compensate for any axial force caused by the fluid. In this respect, the torque head 220 may move axially upward to relieve an upward axial force created by the fluid pressure from the circulating fluid.

Figure 12 is a sectional view illustrating the torque head 220 in a fully extended upward position. As shown, the cylinder 505, the torque head 220, and casing 585 have moved axially upward relative to the apparatus housing 545 and spline mandrel 555. Particularly, fluid from the upper chamber 525 is communicated through the valve assembly 520 into the lower chamber 530, thereby urging the cylinder 505 axially upward until the cylinder upper surface 575 contacts the housing surface 580. If the one or more slips 135 of the torque head 220 become stuck to the casing 585 during the operation of the torque head 220, an upward axial force on the apparatus housing 545 may be translated to the torque head 220 to release the slips 135 from the casing 585.

Figure 13 is a sectional view illustrating an alternate embodiment of a compensator apparatus 600 positioned prior to the threading operation. In a similar manner as described above in relation to the compensator apparatus 500 of Figures 7-12, the compensator apparatus 600 compensates for the weight of casing 685 and permits the torque head 220 to move axially during the operation of the system. The compensator apparatus 600 includes one or more fluid-operated cylinders 605 mechanically attached to the housing 105 of the torque head 220.

The fluid-operated cylinders 605 may be manually or remotely operated. Each of the cylinders 605 includes a rod 625 that extends into the housing 105. As illustrated, the lower end of the rod 625 is mechanically attached to a spline mandrel 655. The fluid cylinders 605 further include an upper port 610 and a lower port 615 which are in fluid communication with a valve assembly 620. The valve assembly 620 may be located near the rig floor and may be manually or remotely operated to adjust the fluid pressure in the cylinders 605, thereby extending or retracting the rods 625. The extension of the rods 625 of the cylinders 605 moves the torque head 220 axially upward relative to the spline mandrel 655. Conversely, the retraction of the rods 625 moves the torque head 220 axially downward relative to the spline mandrel 655.

The housing 105 of the torque head 220 is capable of moving relative to the spline mandrel 655 in the embodiment shown in Figure 13. The housing 105 is also moveable independent of the top drive 200.

As shown in Figure 13, the housing 105 of the torque head 220 includes a housing face 695 and a housing surface 680. The housing face 695 is operatively engaged to the spline mandrel 655 to form a torque connection, thereby allowing torque to be transmitted from the top drive 200 (shown in Figure 2) through the compensator apparatus 600 to the torque head 220. The torque connection is maintained throughout the axial movement of the torque head 220. In other words, a torque may be transmitted from the top drive 200 to the torque head 220 throughout the operation, including the threading and the drilling operation. The torque connection may be constructed and arranged from a spline arrangement as shown, a key and groove arrangement, or any other type of torque connection known in the art.

As illustrated on Figure 13, the torque head 220 may move axially up or down depending on the desired function of the compensator apparatus 600. The torque head 220 in this position may be utilized to connect the casing 685 to a subsequent lower string of casing (not shown) during the threading operation. Thereafter, the torque head 220 may move axially downward as illustrated in Figure 14.

Figure 14 is a sectional view illustrating the torque head 220 in a fully extended downward position, which is the typical position of the torque head 220 after the threading operation. As shown, the one or more cylinder rods 625 have retracted,

causing the torque head 220 and the casing 685 to move axially downward relative to the spline mandrel 655 until a mandrel surface 665 contacts the housing surface 680. Fluid from the upper port 610 is communicated through the valve assembly 620 (shown in Figure 13) into the lower port 615, thereby urging the rod 625 axially upward relative to the spline mandrel 655. In other words, as the casing 685 is threaded into the subsequent lower casing (not shown), any axially downward movement due to the threading engagement is compensated by the downward movement of the torque head 220 and the one or more cylinders 605, thereby minimizing tension created during the threading operation between the torque head 220 and the top drive 200 (shown in Figure 2). In a similar manner, the breaking out of the threaded connection may be accomplished by reversing the order of operation.

As illustrated in Figure 14, the torque head 220 is fully extended. In this arrangement, the torque head 220 is positioned to circulate fluid through the entire string of casing (not shown). In this position, the torque head 220 may also compensate for any axial force caused by the fluid. In this respect, the torque head 220 may move axially upward to relieve an upward axial force created by the fluid pressure from the circulating fluid. Furthermore, the fully extended torque head 220 may be utilized to pick up another casing similar to casing 685. Thereafter, the torque head 220 and the casing 685 may move axially upward as shown in Figure 15.

Figure 15 is a sectional view illustrating the torque head 220 in a fully extended upward position. As shown, the rod 625 has extended, thereby causing the torque head 220 and casing 685 to move axially upward relative to the spline mandrel 655. Fluid from the lower port 615 is communicated through the valve assembly 620 (shown in Figure 13) into the upper port 610, thereby extending the rod 625 into the cylinder 605.

Figure 16 is an isometric view illustrating the preferred embodiment of the compensating apparatus 600. As clearly shown, a plurality of cylinders 605 are rigidly attached to the housing 105 of the torque head 220. As further shown, the spline mandrel 655 is engaged with the housing face 695.

In the embodiments shown in Figures 7-16, the compensator apparatus 500, 600 may be utilized to compensate when drilling with casing as well as while making up

and/or breaking out threadable connections between casing sections and/or casing strings. The compensator apparatus 500, 600 shown and described in relation to Figures 7-16 may be used when using the cementing/circulating tool 2 shown and described in relation to Figures 1-6 to perform a drilling with casing operation.

5 Figure 17 shows a tensile load isolating elevator 800 according to one aspect of the present invention. The load isolating elevator 800 may be used to isolate a tensile load from a top drive connection 720.

The load isolating elevator 800 may be utilized to isolate tensile load from the top drive connection when utilizing the gripping head 220 or 11 and associated
10 circulating/cementing tool 2 shown and described in relation to Figures 1-6. Additionally, the load isolating elevator 800 may be utilized with the compensator apparatus 500 or 600 shown and described in relation to Figures 7-16.

The load isolating elevator 800 may be used with a top drive system as shown in Figure 17. The system includes a top drive 710, a gripping head 730, and the load
15 isolator elevator 800. The top drive 710 may be any suitable top drive known to a person of ordinary skill in the art. The quill 715, or spindle, interconnects the top drive 710 and the gripping head 730, thereby forming the top drive connection 720. In this respect, torque may be transmitted from the top drive 710 to the gripping head 730. The gripping head 730 is shown gripping a tubular 705, such as a casing.

20 The gripping head 730 may be an external gripping head such as a torque head, an internal gripping head such as a spear, or any suitable gripping head known to a person of ordinary skill in the art. An example of a suitable torque head is disclosed in U.S. Patent Application No. 09/550,721, filed on April 17, 2000, entitled "Top Drive Casing System", which was above incorporated by reference. Figure 17 illustrates
25 another example of a suitable torque head 730. As shown, the torque head 730 includes a housing 732 and a connector sub 734 for connecting the torque head 730 to the quill 715 of the top drive 710. The torque head 730 may be equipped with one or more gripping members 736 for holding the casing 705.

The torque head 730 may also include a fill-up/circulating tool 740 for circulating
30 drilling fluid. The circulating tool 740 is shown with an end attached to the torque head

730 and an end inserted into the casing 705. The circulating tool 740 may include one or more sealing elements 743 to seal an interior of the casing 705 in order to circulate fluid or mud. Aspects of the present invention are usable with any suitable fill-up/circulating tool known to a person of ordinary skill in the art. In one embodiment, the
5 fill-up/circulating tool 740 may include the circulating/cementing tool 2 shown and describe in relation to Figures 1-16.

The load isolator elevator 800 may be suspended by bails 750 from eyes 716 of the top drive 710. In one embodiment, the elevator 800 is connected to the bails 750 through attachment members 805, such as hooks or eyes. The attachment members
10 805 are connected to the isolator body 810 of the elevator 800.

Figure 18 is a cross-sectional view of the elevator 800 according to aspects of the present invention. As illustrated in Figure 18, the isolator body 810 defines a first opening 813 at one end for maintaining a torque body 820. The isolator body 810 also has a second opening 814 at another end to accommodate the casing 705. Preferably,
15 a diameter of the first opening 813 is larger than a diameter of the second opening 814. In one embodiment, the isolator body 800 defines two arcuate portions 811, 812 hingedly connected and hingedly openable from at least one side of the elevator 800.

In one embodiment, the torque body 820 defines a slip bowl 820. The slip bowl 820 is concentrically disposed in the first opening 813 of the isolator body 810.
20 Preferably, the slip bowl 820 defines two portions 821, 822 hingedly connected to form an annular member. The slip bowl 820 further defines a conical bore 824 that is concentric with the slip bowl 820. The conical bore 824 is tapered downwardly to support one or more slips 840. Each slip 840 defines an arcuate, wedge-shaped portion having a straight front surface and a sloped back surface that matches the
25 conical bore 824 of the slip bowl 820. The slips 840 may be mounted in spaced apart relation about the slip bowl 820 with the front surface closest to the central axis of the bore 824. The front surface of the slip 840 may include one or more inserts 845 for gripping the casing 705. In another embodiment, the tapered surface of the conical bore 824 may include a tapered shoulder 826, as shown in Figure 18, to limit the
30 downward movement of the slips 840 relative to the slip bowl 820.

The slips 840 are moveable axially within the slip bowl 820, preferably by one or more piston and cylinder assemblies (not shown) attached to the upper portion of the slips 840. Specifically, in one embodiment, the slips 820 are attached to a ring (not shown) having cylinders (not shown) which move the slips 820.

5 The slip bowl 820 is supported in the elevator 800 using a bearing assembly 830. The bearing assembly 830 may include one or more bearings 835 disposed between two races 831, 832. In one embodiment, the bearing assembly 830 is disposed between the slip bowl 820 and the isolator body 810. Preferably, a first race 831 is disposed on a lower portion of the slip bowl 820, and a second race 832 is
10 disposed on an interior surface of the isolator body 810. The bearing assembly 830 is adapted and designed to allow the slip bowl 820 to rotate relative to the isolator body 810. Additionally, the bearing assembly 830 is adapted and designed to transmit axial load from the slip bowl 820 to the isolator body 810. In this respect, the bearing assembly 830 acts both as a thrust and a radial bearing. The isolator body 810, in turn,
15 transmits the axial load to the bails 750. In this manner, tensile load may be isolated from the top drive connection 720 or the torque head 730 during operation. Aspects of the present invention encompass other suitable types of bearing assemblies or load transferring members known to a person of ordinary skill in the art, so long as the load transferring member is capable of transferring tensile load from the slip bowl 820 to the
20 isolator body 810, while allowing rotation relative thereto.

The bails 750 of the top drive system may attempt to twist during rotation; therefore, the bails 750 may be rigidly attached to the top drive track or body (or any other non-rotating body). A holding system (not shown) may be attached to the isolator body 810 and ride on the same rails (or other non-rotating member) as the top drive
25 710 (or any other non-rotating body) to prevent the twisting of the bails 750 and take the reactionary torque when the casing 705 is rotated. The holding system is detachable in one embodiment.

In another embodiment, a plurality of bearing assemblies may be used to isolate tensile load from the top drive connection. One or more radial bearing assemblies may
30 be disposed between the annular area between the isolator body 810 and the slip bowl 820. The radial bearing assemblies allow the slip bowl 820 to rotate relative to the

isolator body 810. Additionally, one or more thrust bearing assemblies may be disposed at a lower portion of the slip bowl 820 between the slip bowl 820 and the isolator body 810. The thrust bearing assembly may transfer the load on the slip bowl 820 to the isolator body 810.

5 In operation, an elevator 800 according to aspects of the present invention may be used to isolate the tensile load from the torque head 730 and the top drive connection 720. Referring to Figure 17, a top drive system is shown having a torque head 730 connected to the top drive 710. Also shown is an elevator 800 operatively connected to the top drive 710. The casing 705 is shown gripped by the gripping
10 members 736 of the torque head 730 and the slips 840 of the elevator 800. Additionally, a fill-up/circulating tool 740 has been inserted into the casing 705.

In this position, the tensile load of the casing 705 is transferred to the slip bowl 820. In turn, the tensile load is transferred from the slip bowl 820 to the isolator body 810 through the bearing assembly 830, which is then transferred to the bails 750. In
15 this respect, the tensile load is substantially transferred away from the torque head 730.

When the top drive 710 is actuated, torque from the top drive 710 is transferred to the torque head 730, thereby rotating the casing 705. The rotation of the casing 705 also causes the slips 840 and the slip bowl 820 to rotate. During operation, the bails 750 and the detachable holding system tied to the rails that the top drive 710 rides
20 along maintain the elevator 800 in a substantially non-rotational manner relative to the slip bowl 820. The bearing assembly 830 allows the slips 840 and the slip bowl 820 to rotate relative to the isolator body 810. In this manner, tensile load may be isolated from the torque head 730, thereby allowing the torque head 730 to rotate a heavier string of casing 705.

25 The torque head 730 may include the compensator apparatus 500 shown and described in relation to Figures 7-12 above or the compensator apparatus 600 shown and described in relation to Figures 13-16 above. When the compensator apparatus 500 or 600 is utilized with the torque head 730, the compensator apparatus 500 or 600 allows release from the slips 840 when the casing 705 is supported at the rig floor by a
30 spider/slip system.

In another aspect, an isolator adapter 900 may be coupled to the top drive 910 to isolate tensile load from the quill 915 of the top drive 910 as shown in Figure 19. The isolator adapter 900 may also transfer torque to a drilling apparatus 920 attached therebelow. It is understood that the drilling apparatus 920 may include any suitable apparatus typically attached to a top drive, including, but not limited to, a torque head, a spear, and a joint compensator, as well as tubulars such as casing and drill pipe, as is known to a person of ordinary skill in the art. A track system (not shown) may be included with the system of Figure 19 that rides on the rails (or any other non-rotating member) of the top drive 910 (or any other non-rotating body) connected to the isolator body 950 to oppose the reactionary torque transmitted through the bearings 955 and 960.

The isolator adapter 900 includes a torque body 925 concentrically disposed in the isolator body 950. The torque body 925 defines an upper body 930 at least partially disposed in a lower body 940. The upper body 930 is coupled to the lower body 940 using a spline and groove connection 937. Any suitable spline and groove assembly known to a person of ordinary skill in the art. A section of the spline and groove on the lower body is shown as 945.

An upper portion of the torque body 925 includes a first coupling 931 for connection to the quill 915 and a lower portion includes a second coupling 941 for connection to the drilling apparatus 920. In one embodiment, the first and second couplings 931, 941 are threaded connections. Preferably, the second coupling 941 has a larger threaded connection than the first coupling 931. The torque body 925 defines a bore 926 therethrough for fluid communication between the top drive 910 and the drilling apparatus 920. One or more seals 975 may be disposed between the upper body 930 and the torque body 925 to prevent leakage.

The isolator body 950 defines an annular member having a central opening 951 therethrough. The torque body 925 is co-axially disposed through the central opening 951 of the isolator body 950. The isolator body 950 is operatively coupled to the top drive 910 using at least two bails 985. One end of the bails 985 is connected to the hooks or eyes 980 of the top drive 910, while the other end is connected to the attachment members 990 of the isolator body 950.

The isolator adapter 900 may further include one or more bearing assemblies 955, 960 for coupling the torque body 925 to the isolator body 950. As shown in Figure 19, a thrust bearing assembly 955 may be disposed between a flange 927 of the torque body 925 and the isolator body 950. The thrust bearing assembly 955 is adapted and designed to transfer tensile or thrust load from the torque body 925 to the isolator body 950. The thrust bearing assembly 955 may include any suitable bearing assembly, such as a roller bearing assembly, or load transferring apparatus known to a person of ordinary skill in the art.

One or more radial bearing assemblies 960 may be disposed in the annular area between the torque body 925 and the isolator body 950. The radial bearing assemblies 960 are adapted and designed to facilitate the rotation of the torque body 925 relative to the isolator body 950. As shown, the radial bearing assemblies 960 may be separated by a spacer 963. A snap ring 966 or any other suitable retaining means is used to retain the bearing assemblies 960 in the isolator body 950. It is understood that a bearing assembly acting as both a thrust and radial bearing, such as the bearing assembly described in the above elevator embodiment, may be used without deviating from the aspects of the present invention.

In operation, the isolator adapter 900 is disposed between the top drive 910 and the drilling apparatus 920. The upper body 930 is connected to the quill 915, while the lower body 940 is connected to the drilling apparatus 920. The isolator body 950 is operatively connected to the top drive 910 using the bails 985. Because the bails 985 are a predetermined length, the spline and groove connection 937 allows the upper body 930 to move axially relative to the lower body 940 in order to compensate for the axial distance required to threadedly connect the upper body 930 to the top drive 910. Once connected, the tensile load of the drilling apparatus 920 is transferred to the lower body 940, which, in turn, transfers the load to the isolator body 950 via the thrust bearing assembly 955. The tensile load is ultimately transferred to the bails 985. In this respect, the tensile load is isolated from the quill 915 of the top drive 910. Optionally, in another aspect, a universal joint (not shown) may be added between the quill thread 931 and the body 930 to allow connection of the pipe to the thread 941 and/or to allow the gripping device (not shown) to grip the casing or pipe when located off the well center.

The isolator adapter 900 may also transmit torque from the top drive 910 to the drilling apparatus 920. The torque is initially transferred from the quill 915 to the upper body 930 through the threaded connection 931. Thereafter, the torque is transferred to the lower body 940 via the spline and groove connection 937. The lower body 940 then
5 transfers the torque to the drilling apparatus 920 by a threaded connection 941, thereby rotating the drilling apparatus 920.

One advantage of the present invention is that existing top drive systems may be retrofitted to handle a higher tensile load during operation. In one aspect, the first and second couplings 931, 941 may be designed and rated to carry different loads. As
10 schematically shown in Figure 19, the second coupling 941 is larger than the first coupling 931. The first coupling 931 is designed to be connected to many existing top drive quills 915. The second coupling 941 is designed to be connected to a drilling apparatus 920 redesigned with a larger threaded connection in order to increase its tensile load capacity. For example, the first coupling 931 may include a 6 5/8
15 connection for connecting to a quill 915 of an existing top drive 910. On the other hand, the second coupling 941 may include an 8 5/8 connection for connecting to a redesigned drilling apparatus 920. In this manner, many existing top drives may be retrofitted to handle a higher tensile load during drilling, thereby allowing the same top drive to drill deeper.

In another aspect, the present invention provides an apparatus 1000 for
20 controlling the torque provided by the top drive 710 during tubular connection or disconnection. Figure 20 is a schematic representation of the apparatus 1000 for controlling a top drive 710. As shown in Figure 20, the top drive 710 is connected to a pump 1010 for supplying fluid pressure. A pressure relief valve 1020, or dump valve,
25 may be disposed on the fluid supply line 1030 connecting the pump 1010 to the top drive 710. The pressure relief valve 1020 may be adapted and designed to redirect fluid in the supply line 1030 to a return line 1040 when the pressure in the supply line 1030 reaches a predetermined pressure. In this respect, the torque generated by the top drive 710 is limited by the pressure relief valve 1020. In this manner, the torque
30 provided to connect or disconnect tubulars may be controlled to prevent damage to the connecting threads. It must be noted that aspects of the present invention may be

used with any suitable pressure relief valve known to a person of ordinary skill in the art.

The embodiments shown and described in relation to Figures 1-20 may be utilized with casing and/or any other tubular body, including but not limited to drill pipe, tubing, and liner. Embodiments of Figures 1-20 are usable when running casing, 5 drilling with casing, lowering or running one or more tubulars into a wellbore, retrieving/fishing one or more tubulars from the wellbore, and/or threading tubulars together or separating threaded connections between one or more tubulars. The systems of Figures 1-20 may be utilized to rotate the entire casing, a portion of the casing (such as a drill shoe or drill bit) may be rotated by a mud motor disposed on the 10 casing, and/or the casing may be lowered into the earth while circulating drilling fluid without rotating any portion of the casing.

An embodiment of the present invention provides an apparatus for use while drilling with casing comprising a gripping member for grippingly engaging the casing; 15 and a circulating seal member for circulating fluid through the casing while drilling with the casing, wherein the circulating seal member is interchangeable with a cementing plug holder having a fluid path therethrough for circulating a physically alterable bonding material through the casing. In one aspect, the physically alterable bonding material is introduced into the casing below a top drive connected above the gripping 20 member.

Another embodiment of the present invention provides an apparatus for use while drilling with casing comprising a gripping member for grippingly engaging the casing; and a circulating seal member for circulating fluid through the casing while drilling with the casing, wherein the circulating seal member is interchangeable with a 25 cementing plug holder having a fluid path therethrough for circulating a physically alterable bonding material through the casing and the cementing plug holder comprises at least one plug releasable into the casing by a slidable mandrel. In one aspect, the slidable mandrel translates longitudinally to release the at least one plug. In another aspect, fluid introduced behind the slidable mandrel translates the slidable mandrel.

Another embodiment of the present invention provides an apparatus for use 30 while drilling with casing comprising a gripping member for grippingly engaging the

casing; and a circulating seal member for circulating fluid through the casing while drilling with the casing, wherein the circulating seal member is interchangeable with a cementing plug holder having a fluid path therethrough for circulating a physically alterable bonding material through the casing, and further including a compensator apparatus disposed adjacent the gripping member. In one aspect, the compensator apparatus allows substantially co-axial movement of the casing relative to a top drive. In an aspect, the top drive is operatively connected to the compensator apparatus.

Another embodiment of the present invention provides an apparatus for use while drilling with casing comprising a gripping member for grippingly engaging the casing; and a circulating seal member for circulating fluid through the casing while drilling with the casing, wherein the circulating seal member is interchangeable with a cementing plug holder having a fluid path therethrough for circulating a physically alterable bonding material through the casing, and further including a compensator apparatus disposed adjacent the gripping member, wherein the compensator apparatus includes a cylinder mechanically attached at one end to the gripping member and an opposite end of the cylinder operatively attached to a mandrel to form a torque connection. In one aspect, the torque connection is constructed and arranged from a spline arrangement. In another aspect, the cylinder is moveable axially relative to the mandrel, thereby allowing the gripping member to move axially relative to a top drive while maintaining the torque connection.

Another embodiment of the present invention provides an apparatus for use while drilling with casing comprising a gripping member for grippingly engaging the casing; a circulating seal member for circulating fluid through the casing while drilling with the casing, wherein the circulating seal member is interchangeable with a cementing plug holder having a fluid path therethrough for circulating a physically alterable bonding material through the casing; a top drive having an isolator body operatively connected thereto, the gripping member at least partially disposed in the isolator body and rotatable relative to the isolator body; and a bearing assembly located between the isolator body and the gripping member to transfer a tensile load from the gripping member to the isolator body. In one aspect, the bearing assembly permits relative rotation between the isolator body and the gripping member.

In another embodiment, the present invention includes an apparatus for drilling with casing comprising a head having at least one dart disposed therein; a torque head for gripping a casing; and a cementing head including at least one plug. In one aspect, the apparatus further comprises a top drive operatively attached to the head, wherein
5 the top drive provides rotational torque to the torque head. In an embodiment, the apparatus further comprises a compensating apparatus disposed at least partially within the torque head. In a yet further embodiment, the compensating apparatus further comprises a cylinder mechanically attached at one end to the torque head and an opposite end of the cylinder operatively attached to a mandrel to form a torque
10 connection. In one aspect, the torque connection is a spline arrangement. In a yet further embodiment, the cylinder moves axially relative to the mandrel, thereby allowing the torque head to move axially relative to the top drive while maintaining the torque connection.

In another embodiment, the present invention includes a load isolator apparatus
15 for use with a top drive, the top drive adapted to rotate a tubular, comprising an isolator body operatively connected to the top drive; a torque body at least partially disposed in the isolator body, wherein the torque body is rotatable relative to the isolator body; and a bearing assembly disposed between the isolator body and the torque body, wherein the bearing assembly transfers a tensile load from the torque body to the isolator body.
20 In one aspect, the bearing assembly allows relative rotation between the isolator body and the torque body. In another embodiment, the present invention includes a load isolator apparatus for use with a top drive, the top drive adapted to rotate a tubular, comprising an isolator body operatively connected to the top drive; a torque body at least partially disposed in the isolator body, wherein the torque body is rotatable relative
25 to the isolator body; a bearing assembly disposed between the isolator body and the torque body, wherein the bearing assembly transfers a tensile load from the torque body to the isolator body; and a radial bearing assembly for allowing relative rotation between the isolator body and the torque body.

In another embodiment, the present invention includes a load isolator apparatus
30 for use with a top drive, the top drive adapted to rotate a tubular, comprising an isolator body operatively connected to the top drive; a torque body at least partially disposed in the isolator body, wherein the torque body is rotatable relative to the isolator body; a

bearing assembly disposed between the isolator body and the torque body, wherein the bearing assembly transfers a tensile load from the torque body to the isolator body; and one or more gripping members for gripping the tubular. In one aspect, the one or more gripping members are disposed in a bore of the torque body. In one embodiment, the load isolator apparatus further comprises one or more inserts disposed on a surface of the one or more gripping members.

In another embodiment, the present invention includes a load isolator apparatus for use with a top drive, the top drive adapted to rotate a tubular, comprising an isolator body operatively connected to the top drive; a torque body at least partially disposed in the isolator body, wherein the torque body is rotatable relative to the isolator body; and a bearing assembly disposed between the isolator body and the torque body, wherein the bearing assembly transfers a tensile load from the torque body to the isolator body, wherein the torque body comprises an upper body coupled to a lower body such that the upper body is movable axially relative to the lower body and capable of transmitting torque thereto. In one aspect, the upper body is coupled to the lower body using a spline and groove connection.

In another embodiment, the present invention includes a load isolator apparatus for use with a top drive, the top drive adapted to rotate a tubular, comprising an isolator body operatively connected to the top drive; a torque body at least partially disposed in the isolator body, wherein the torque body is rotatable relative to the isolator body; and a bearing assembly disposed between the isolator body and the torque body, wherein the bearing assembly transfers a tensile load from the torque body to the isolator body, wherein the torque body comprises an upper body coupled to a lower body such that the upper body is movable axially relative to the lower body and capable of transmitting torque thereto, wherein a first threaded connection of the torque body is rated for higher loads than a second threaded connection of the torque body. In another embodiment, the present invention includes a load isolator apparatus for use with a top drive, the top drive adapted to rotate a tubular, comprising an isolator body operatively connected to the top drive; a torque body at least partially disposed in the isolator body, wherein the torque body is rotatable relative to the isolator body; and a bearing assembly disposed between the isolator body and the torque body, wherein the bearing assembly transfers a tensile load from the torque body to the isolator body, wherein a first threaded

connection of the torque body is rated for higher loads than a second threaded connection of the torque body. In one aspect, the second threaded connection is threadedly connected to the top drive. In one embodiment, the first threaded connection is threadedly connected to the tubular.

5 In another embodiment, the present invention includes a method of rotating a drilling apparatus having a tensile load using a top drive, comprising operatively connecting a load isolator apparatus to the top drive, the load isolator apparatus comprising a torque body disposed in an isolator body; transferring the tensile load to the torque body; transferring the tensile load from the torque body to the isolator body;
10 and rotating the torque body relative to the isolator body, thereby rotating the drilling apparatus. In one embodiment, the method further comprises providing the load isolator apparatus with one or more bearing assemblies. In one aspect, the one or more bearing assemblies comprise a thrust bearing assembly. In another aspect, the one or more bearing assemblies further comprise a radial bearing assembly.

15 In another embodiment, the present invention includes a method of rotating a drilling apparatus having a tensile load using a top drive, comprising operatively connecting a load isolator apparatus to the top drive, the load isolator apparatus comprising a torque body disposed in an isolator body; transferring the tensile load to the torque body; transferring the tensile load from the torque body to the isolator body;
20 rotating the torque body relative to the isolator body, thereby rotating the drilling apparatus; providing the load isolator apparatus with one or more bearing assemblies, wherein the one or more bearing assemblies comprise a thrust bearing assembly, wherein the thrust bearing assembly facilitates the rotation of the torque body relative to the isolator body.

25 In another embodiment, the present invention includes a method of rotating a drilling apparatus having a tensile load using a top drive, comprising operatively connecting a load isolator apparatus to the top drive, the load isolator apparatus comprising a torque body disposed in an isolator body; transferring the tensile load to the torque body; transferring the tensile load from the torque body to the isolator body;
30 and rotating the torque body relative to the isolator body, thereby rotating the drilling apparatus, wherein operatively connecting a load isolator apparatus to the top drive

comprises threadedly connecting the torque body to a quill of the top drive; and connecting the isolator body to the top drive. In one aspect, the method further comprises compensating for an axial distance of the threaded connection between torque body and the top drive. In another embodiment, the present invention includes a method of rotating a drilling apparatus having a tensile load using a top drive, comprising operatively connecting a load isolator apparatus to the top drive, the load isolator apparatus comprising a torque body disposed in an isolator body; transferring the tensile load to the torque body; transferring the tensile load from the torque body to the isolator body; rotating the torque body relative to the isolator body, thereby rotating the drilling apparatus; and sealing off an area between the torque body and the isolator body to prevent leakage.

Another embodiment of the present invention includes an elevator for use with a top drive, comprising an isolator body; a torque body at least partially disposed in the isolator body, the torque body defining a conical bore; one or more slip members disposed in the conical bore; one or more bearing members disposed between the torque body and the isolator body, wherein the torque body is rotatable relative to the isolator body, and wherein a tensile load acting on the torque body is transferred to the isolator body. In one embodiment, the elevator further comprises one or more attachment members for attaching to a bail operatively connected to the top drive.

Another embodiment of the present invention includes an elevator for use with a top drive, comprising an isolator body; a torque body at least partially disposed in the isolator body, the torque body defining a conical bore; one or more slip members disposed in the conical bore; one or more bearing members disposed between the torque body and the isolator body, wherein the torque body is rotatable relative to the isolator body, and wherein a tensile load acting on the torque body is transferred to the isolator body, wherein the one or more bearing members comprise a radial bearing assembly and a thrust bearing assembly. Another embodiment of the present invention includes an elevator for use with a top drive, comprising an isolator body; a torque body at least partially disposed in the isolator body, the torque body defining a conical bore; one or more slip members disposed in the conical bore; one or more bearing members disposed between the torque body and the isolator body, wherein the torque body is rotatable relative to the isolator body, and wherein a tensile load acting on the torque

body is transferred to the isolator body, wherein the one or more bearing members comprise a bearing assembly acting as both a thrust bearing and a radial bearing.

Another embodiment of the present invention includes a top drive adapter for use with a top drive to rotate a drilling apparatus, comprising an isolator body; a torque
5 body at least partially disposed in the isolator body, the torque body having a first coupling and a second coupling; and one or more bearing members disposed between the torque body and the isolator body, wherein the torque body is rotatable relative to the isolator body, and wherein a tensile load acting on the torque body is transferred to the isolator body. In one embodiment, the adapter further comprises one or more
10 attachment members for attaching to a bail operatively connected to the top drive.

Another embodiment of the present invention includes a top drive adapter for use with a top drive to rotate a drilling apparatus, comprising an isolator body; a torque body at least partially disposed in the isolator body, the torque body having a first coupling and a second coupling; and one or more bearing members disposed between
15 the torque body and the isolator body, wherein the torque body is rotatable relative to the isolator body, and wherein a tensile load acting on the torque body is transferred to the isolator body, wherein the one or more bearing members comprise a radial bearing assembly and a thrust bearing assembly. Another embodiment of the present invention includes a top drive adapter for use with a top drive to rotate a drilling apparatus,
20 comprising an isolator body; a torque body at least partially disposed in the isolator body, the torque body having a first coupling and a second coupling; and one or more bearing members disposed between the torque body and the isolator body, wherein the torque body is rotatable relative to the isolator body, and wherein a tensile load acting on the torque body is transferred to the isolator body, wherein the one or more bearing
25 members comprise a bearing assembly acting as both a thrust bearing and a radial bearing. Another embodiment of the present invention includes a top drive adapter for use with a top drive to rotate a drilling apparatus, comprising an isolator body; a torque body at least partially disposed in the isolator body, the torque body having a first coupling and a second coupling; and one or more bearing members disposed between
30 the torque body and the isolator body, wherein the torque body is rotatable relative to the isolator body, and wherein a tensile load acting on the torque body is transferred to the isolator body, wherein the torque body comprises an upper body at least partially

disposed in a lower body, wherein the upper body is movable axially relative to the lower body and capable of transmitting torque to the lower body.

Another embodiment of the present invention includes an apparatus for controlling the fluid pressure of a top drive supplied by a pump, comprising a fluid supply line disposed between the pump and the top drive for supplying fluid to the top drive; a pressure relief valve disposed on the fluid supply line between the top drive and the pump; and a fluid return line connecting the pressure relief valve and the pump, wherein the pressure relief valve redirects the fluid back to the pump via the fluid return line when a fluid pressure reaches a predetermined level. Another embodiment of the present invention includes an apparatus for regulating an operating fluid from a fluid source to a top drive, comprising a valve disposed between the fluid source and the top drive, wherein the valve directs the operating fluid away from the top drive when a fluid pressure in the top drive reaches a predetermined level!

Another embodiment of the present invention includes an apparatus for cementing a casing within a formation comprising a gripping mechanism for grippingly and sealingly engaging the casing; and a cementing device connected to the gripping mechanism capable of launching at least one plug within the casing without releasing the gripping and sealing engagement with the casing. In one aspect, the gripping mechanism is a torque head. In another aspect, the gripping mechanism is a spear.

Another embodiment of the present invention includes an apparatus for cementing a casing within a formation comprising a gripping mechanism for grippingly and sealingly engaging the casing; and a cementing device connected to the gripping mechanism capable of launching at least one plug within the casing without releasing the gripping and sealing engagement with the casing, wherein an earth removal member is operatively connected to a lower end of the casing. Another embodiment of the present invention includes an apparatus for cementing a casing within a formation comprising a gripping mechanism for grippingly and sealingly engaging the casing; and a cementing device connected to the gripping mechanism capable of launching at least one plug within the casing without releasing the gripping and sealing engagement with the casing, wherein the cementing device launches the at least one plug by sliding a mandrel disposed within the cementing device axially.

Another embodiment of the present invention includes an apparatus for cementing a casing within a formation comprising a gripping mechanism for grippingly and sealingly engaging the casing; and a cementing device connected to the gripping mechanism capable of launching at least one plug within the casing without releasing
5 the gripping and sealing engagement with the casing, wherein the cementing device launches at least one ball into a flow stream.

While the foregoing is directed to embodiments of the present invention, other and further embodiments of the invention may be devised without departing from the basic scope thereof, and the scope thereof is determined by the claims that follow.

Claims:

1. A method of forming a wellbore comprising:
operatively connecting a circulating head to a gripping mechanism;
5 grippingly and sealingly engaging a first tubular with the gripping mechanism;
lowering the first tubular into a formation;
operatively connecting a cementing plug to the gripping mechanism;
grippingly and sealingly engaging a second tubular with the gripping mechanism;
and
10 lowering the second tubular into the formation.
2. The method of claim 1, wherein the first tubular comprises a first casing and the second tubular comprises a second casing.
- 15 3. The method of claim 2, further comprising:
releasing a portion of the cementing plug to plug fluid flow through the second casing; and
introducing a physically alterable bonding material into the second casing.
- 20 4. The method of claim 3, wherein the portion of the cementing plug comprises at least one plug, and wherein releasing the portion of the cementing plug comprises releasing the at least one plug from the remainder of the cementing plug.
5. The method of claim 2, wherein lowering the first casing into the formation
25 comprises rotating at least a portion of the first casing while introducing fluid through the first casing.
6. The method of claim 5, wherein the portion of the first casing is an earth removal member operatively connected to a lower end of the first casing.
- 30 7. The method of claim 1, wherein the cementing plug comprises at least one plug having a bore therethrough.

8. The method of claim 7, wherein the cementing plug comprises a mandrel slidable upon introduction of fluid behind the mandrel.
9. The method of claim 8, wherein the mandrel biases at least one valve in the bore
5 of the at least one plug in an open position.
10. The method of claim 9, wherein sliding the mandrel a first length closes the at least one valve on the at least one plug.
- 10 11. The method of claim 8, wherein releasing the portion of the cementing plug comprises sliding the mandrel a first length to release the at least one plug from a remainder of the cementing plug.
12. The method of claim 1, further comprising:
15 providing a compensator apparatus within the gripping mechanism, the compensator apparatus operatively connected to a top drive; and
allowing the gripping mechanism to translate coaxially with the compensator apparatus relative to the top drive.
- 20 13. The method of claim 1, further comprising:
providing an isolator body operatively connected to a top drive, the gripping mechanism at least partially disposed within the isolator body; and
allowing relative rotation between the isolator body and the gripping mechanism.
- 25 14. The method of claim 13, wherein the isolator body transfers a tensile load from the gripping mechanism to the isolator body.
15. An apparatus for use in drilling with casing comprising:
a tubular body having a fluid flow path therethrough;
30 a circulating seal member and a cementing plug operatively connectible to the tubular body; and
a gripping member for gripping the casing.

16. The apparatus of claim 15, wherein the plug is releasable by fluid pressure.
17. The apparatus of claim 15, wherein the circulating seal member is connectible to the tubular body to circulate fluid while drilling with the casing into a formation.
- 5 18. The apparatus of claim 15, wherein the cementing plug is connectible to the tubular body to set the casing into the formation using a physically alterable bonding material.
- 10 19. The apparatus of claim 15, wherein the cementing plug comprises at least two plugs, wherein the at least two plugs are releasable by longitudinal translation of a mandrel within a bore of the tubular body.
- 15 20. An apparatus for compensating a gripping head comprising:
a mandrel operatively engaged to a gripping head housing to form a torque-bearing connection; and
at least one biasing member connected between the mandrel and the gripping head.
- 20 21. The apparatus of claim 20, wherein the biasing member causes the gripping head to move axially relative to the mandrel while maintaining the torque-bearing connection.
- 25 22. A method of cementing a casing within a formation, comprising:
providing a gripping mechanism connected to a cementing assembly;
grippingly and sealingly engaging the casing with the gripping mechanism;
moving the casing to a depth within the formation; and
cementing the casing within the formation using the cementing assembly without
30 releasing the gripping and sealing engagement of the casing.
23. The method of claim 22, wherein the gripping mechanism is a torque head.

24. The method of claim 22, wherein the gripping mechanism is a spear.

25. The method of claim 22, wherein moving the casing comprises lowering and rotating at least a portion of the casing into the formation.

5

26. The method of claim 25, wherein the portion of the casing is an earth removal member operatively connected to its lower end.

10 27. The method of claim 22, wherein cementing the casing comprises selectively releasing into the casing at least one plug located within the cementing assembly.

28. The method of claim 27, wherein the at least one plug is released by axial movement of a slidable mandrel disposed within the cementing assembly.

15 29. The method of claim 27, wherein the at least one plug is released by at least one ball selectively launched into a flow stream using a plug injector disposed above the cementing assembly.

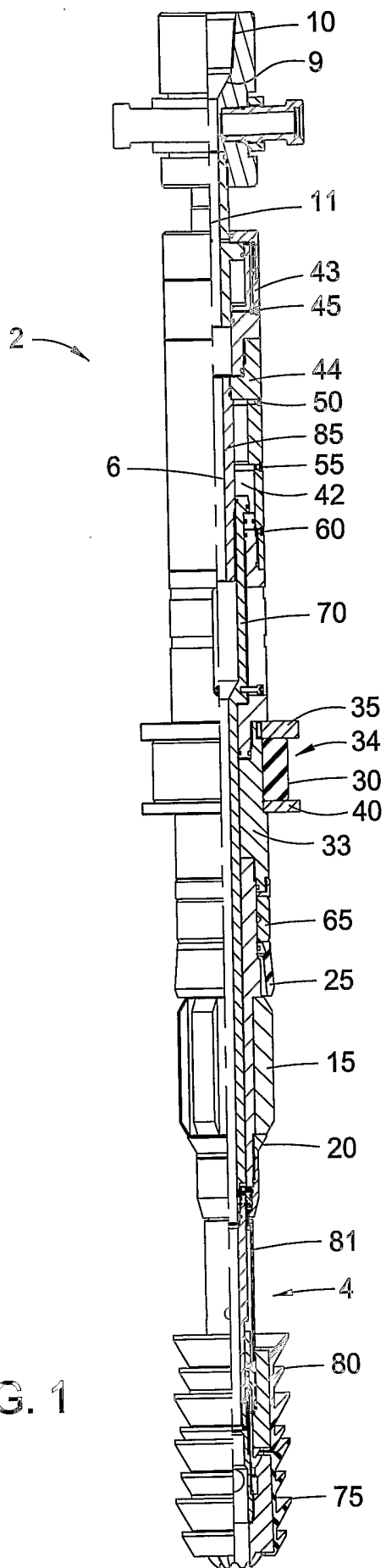

FIG. 1

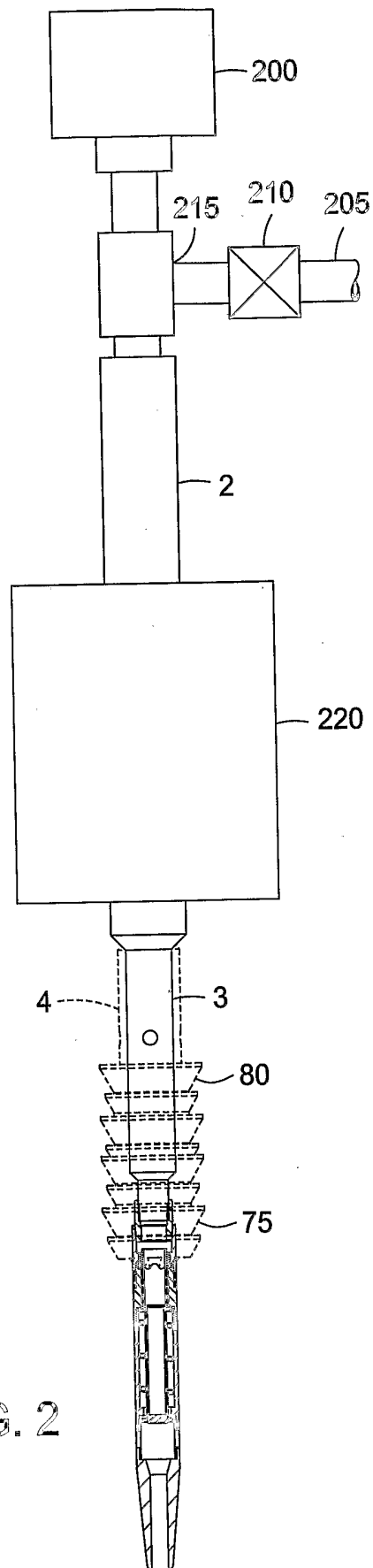

FIG. 2

2/17

FIG. 3

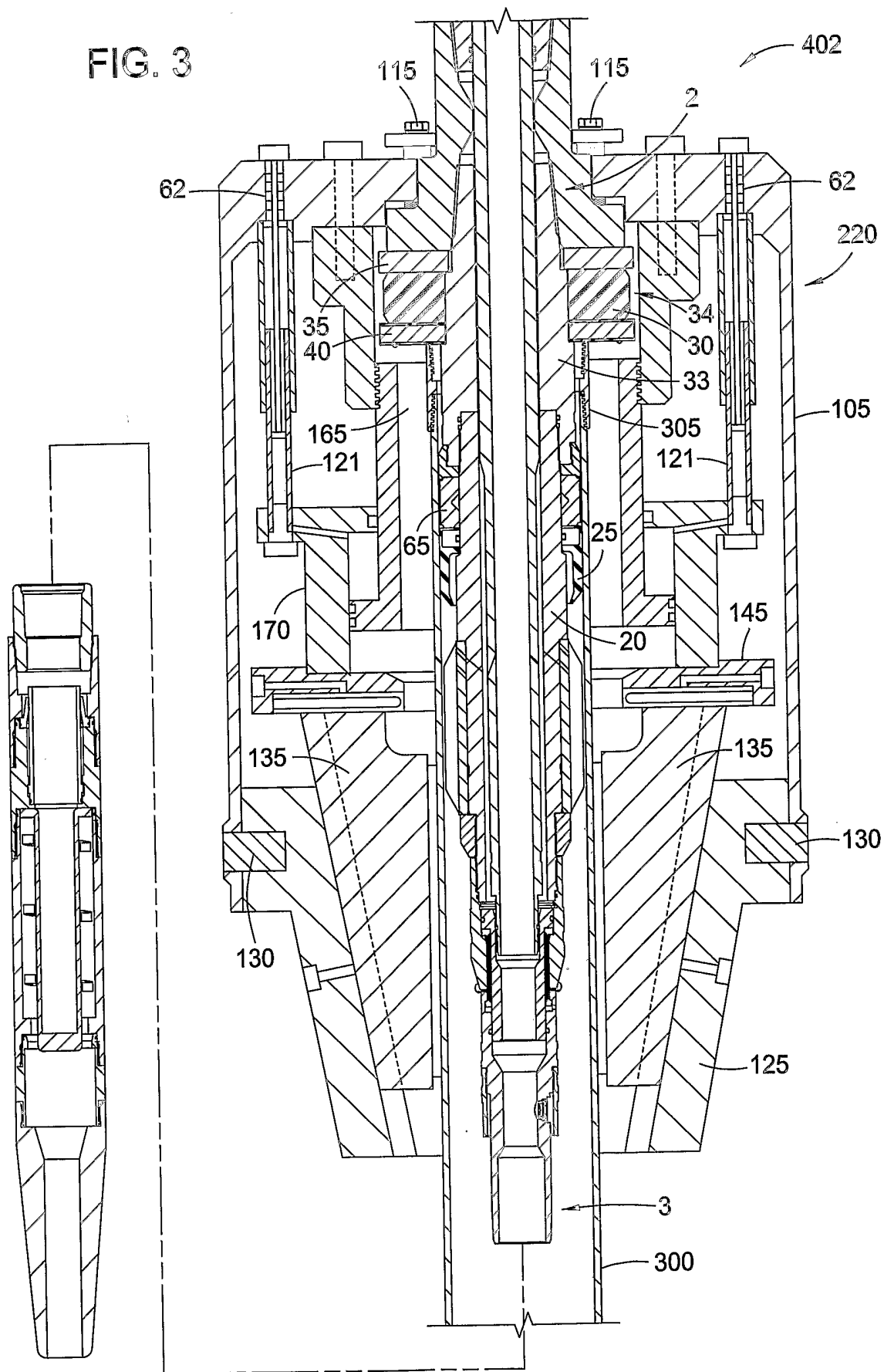
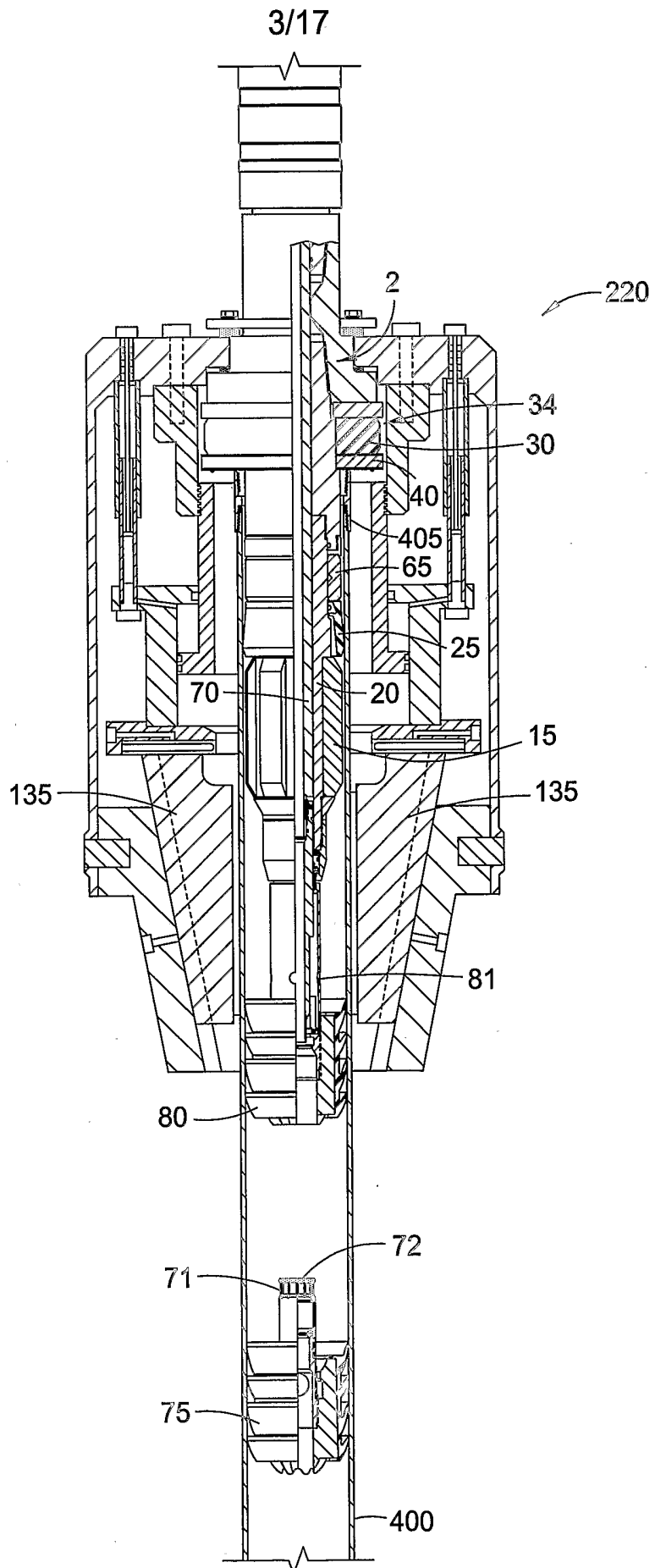

FIG. 4



4/17

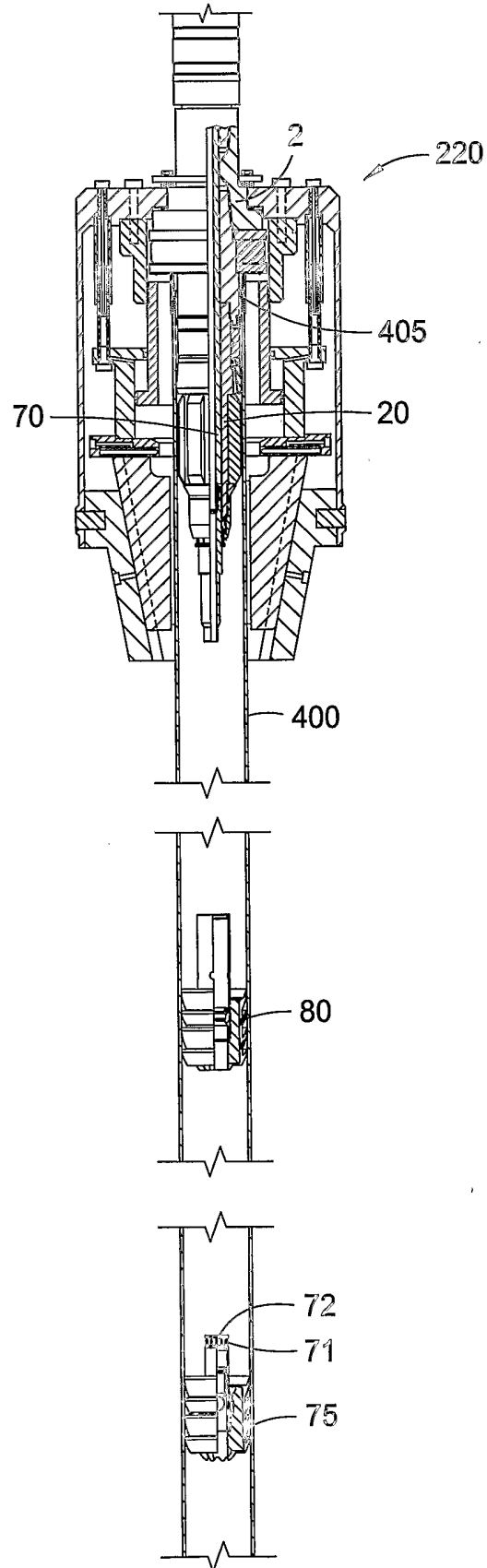

FIG. 5

5/17

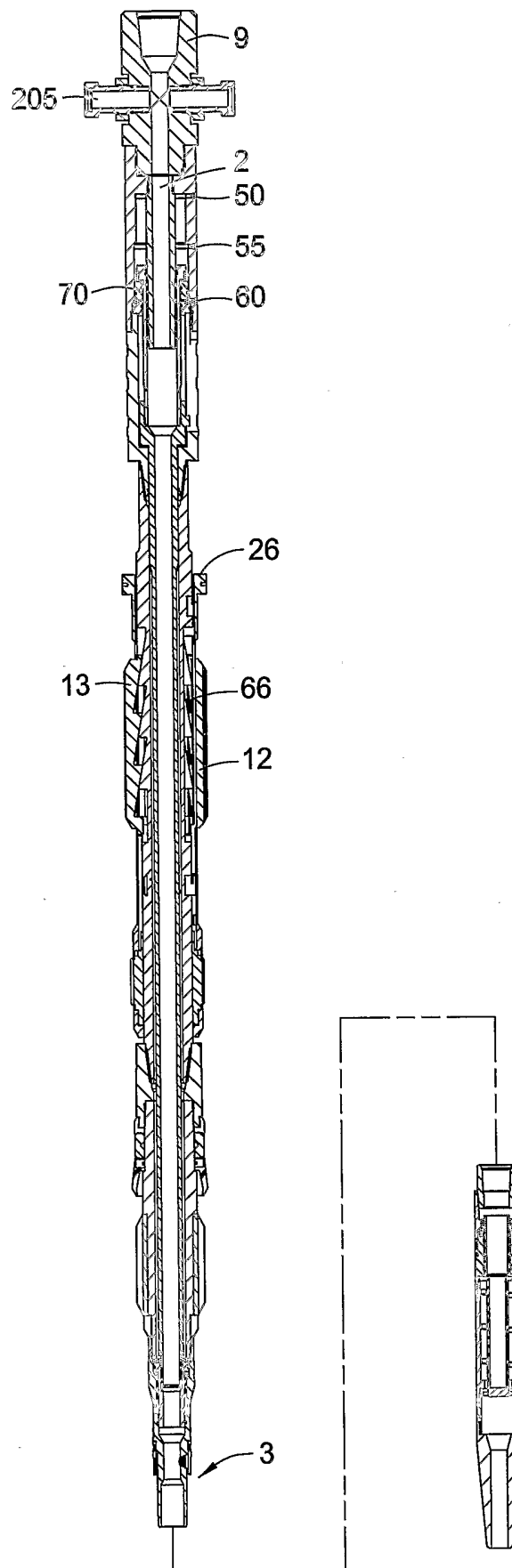
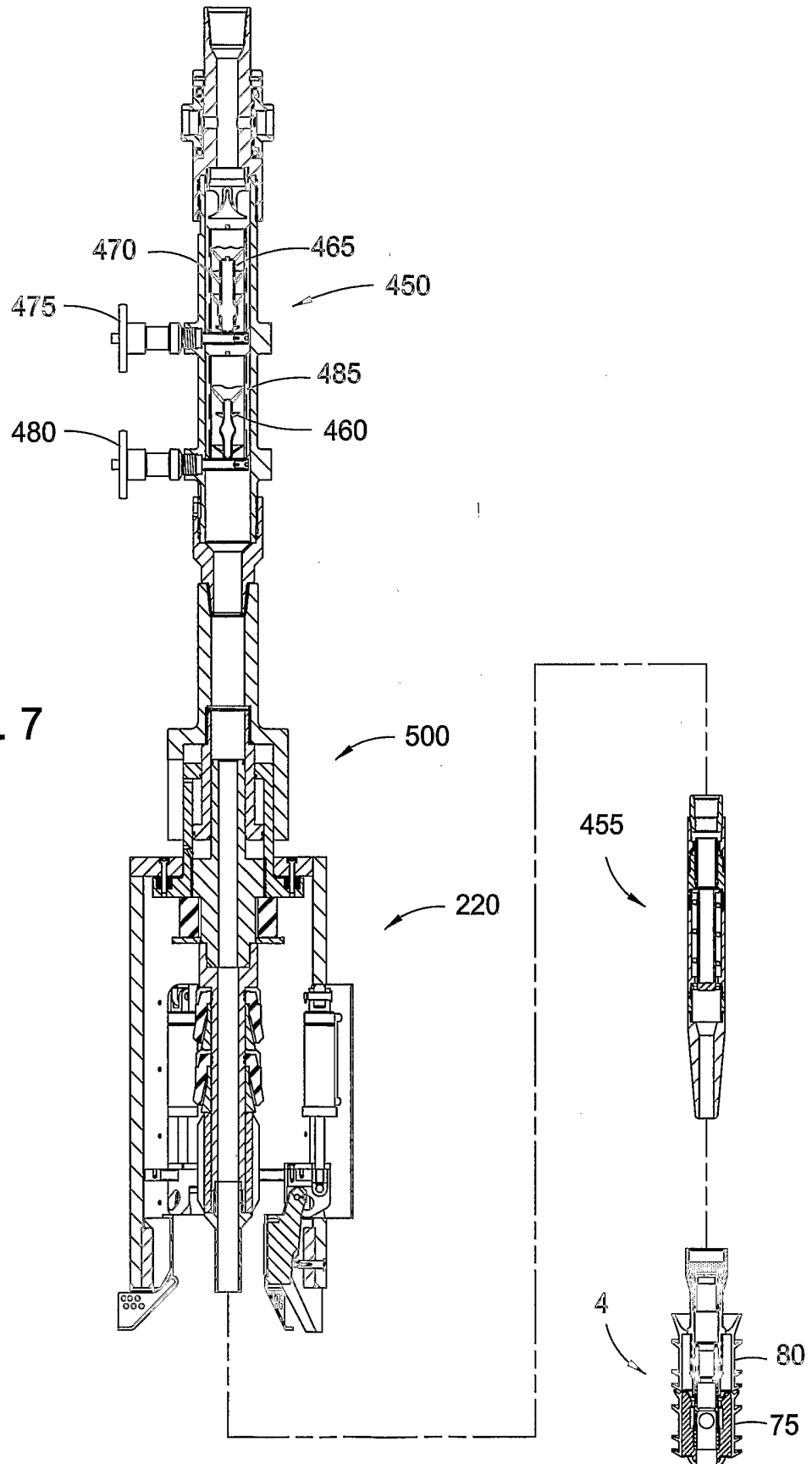

FIG. 6

6/17



7/17

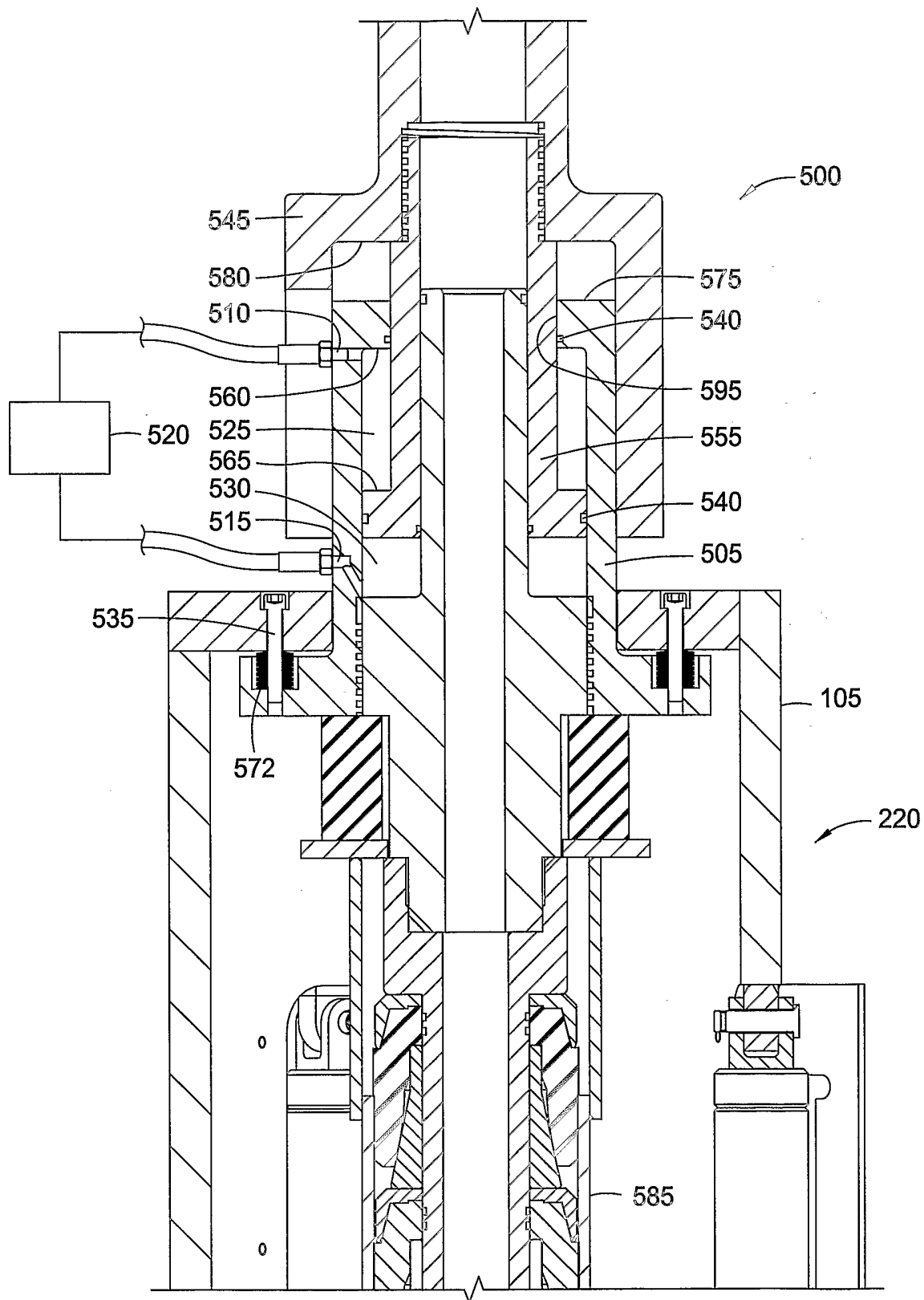

FIG. 8

8/17

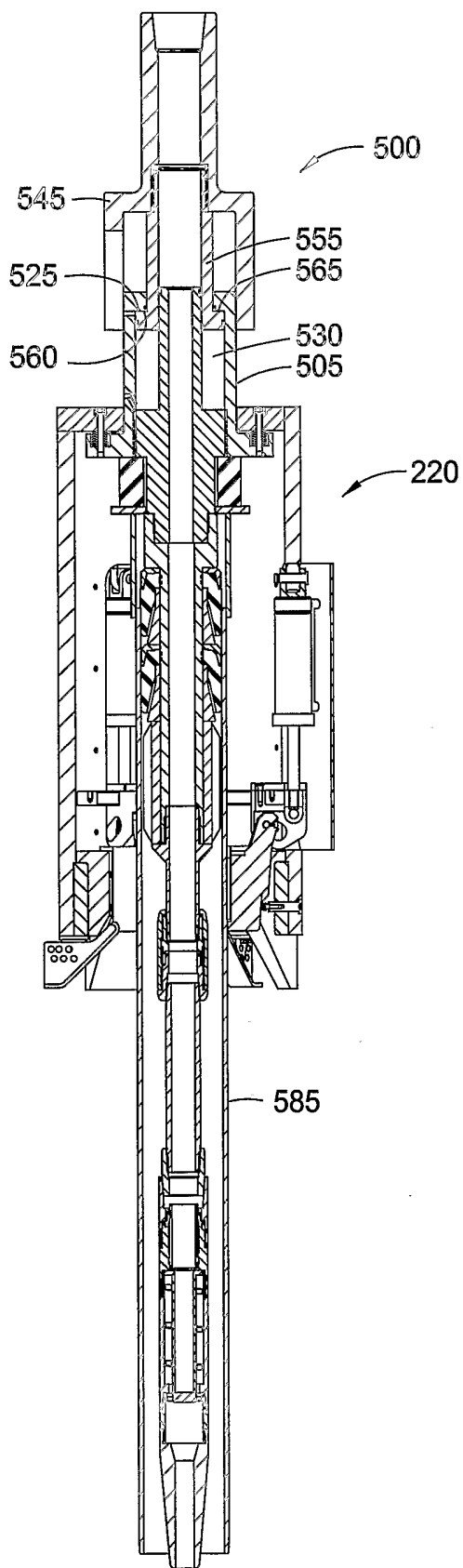

FIG. 9

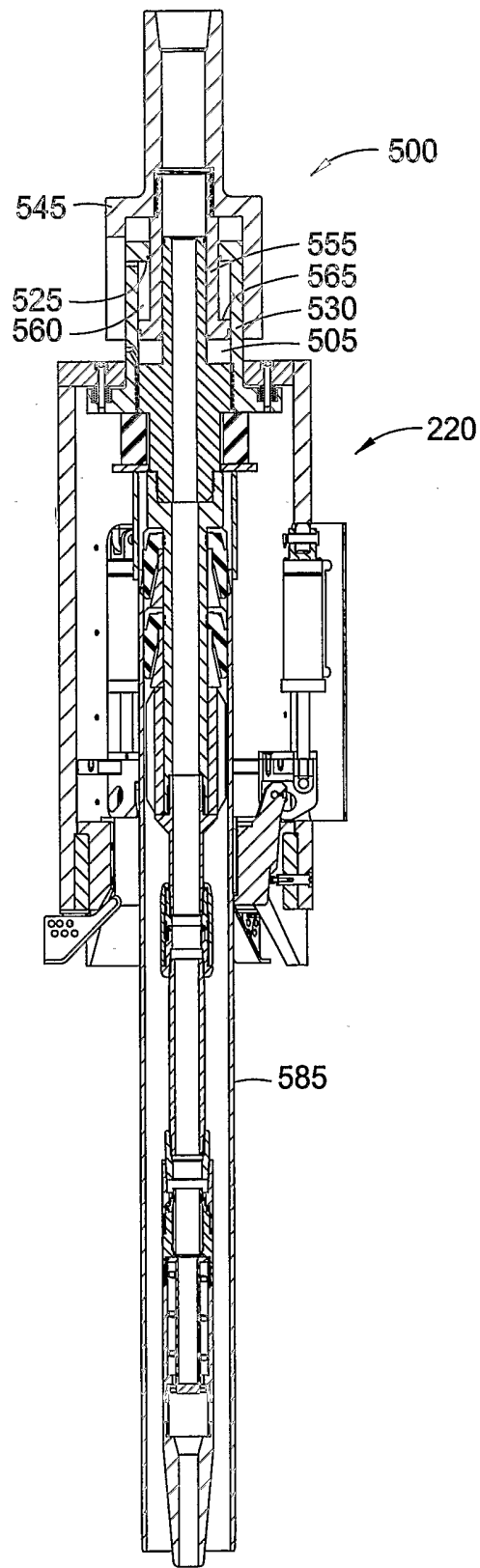

FIG. 10

9/17

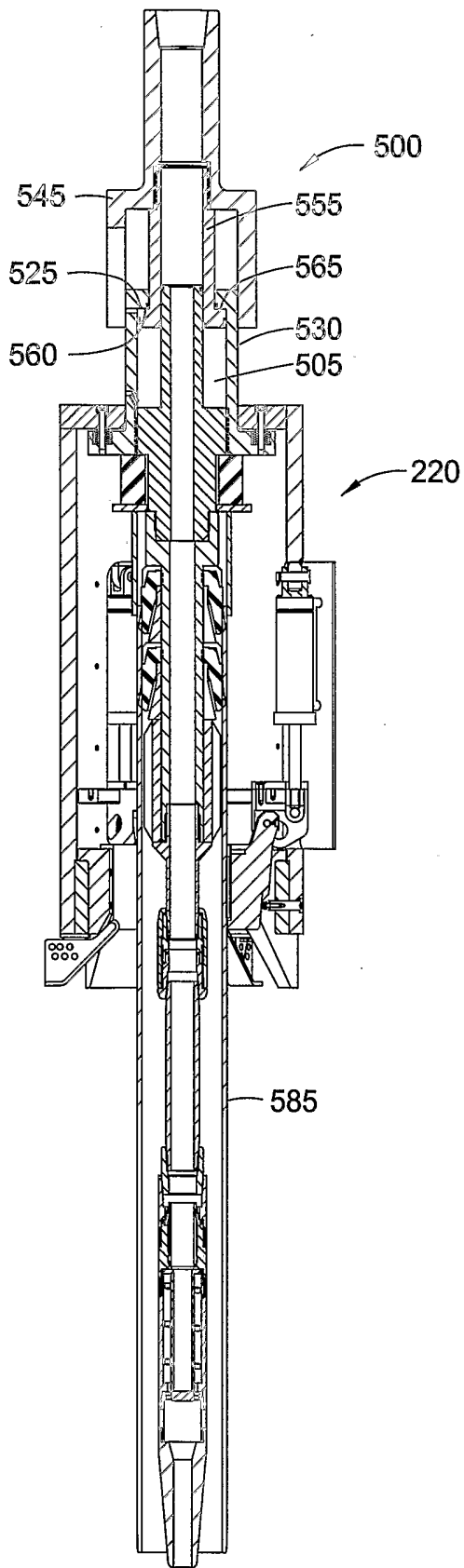

FIG. 11

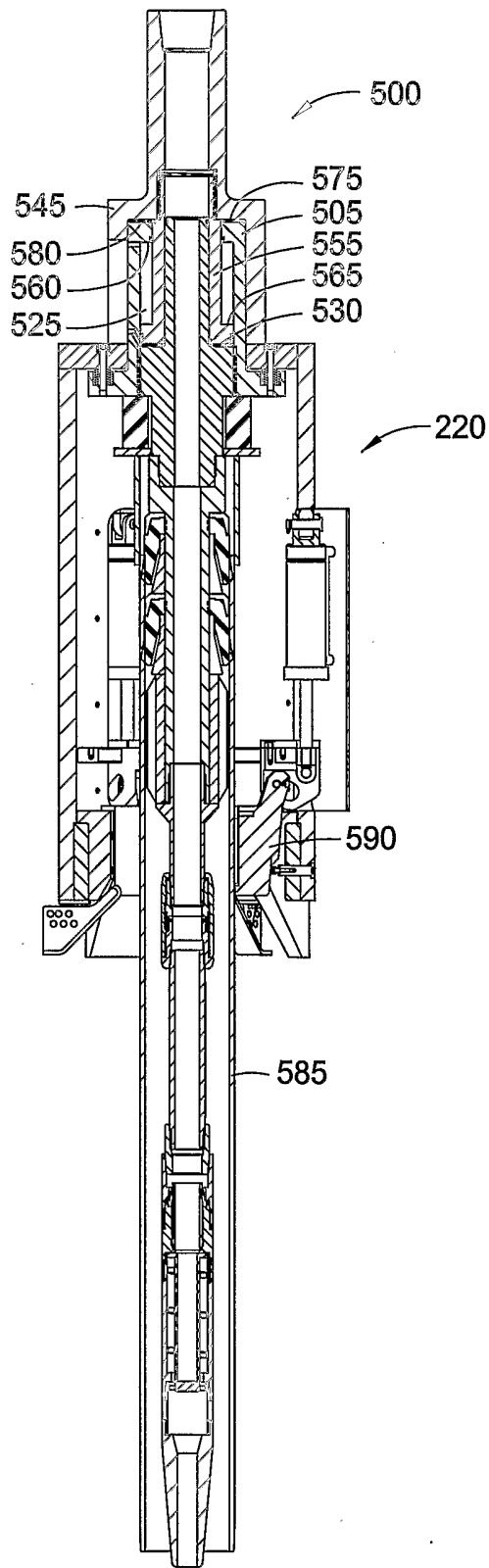

FIG. 12

10/17

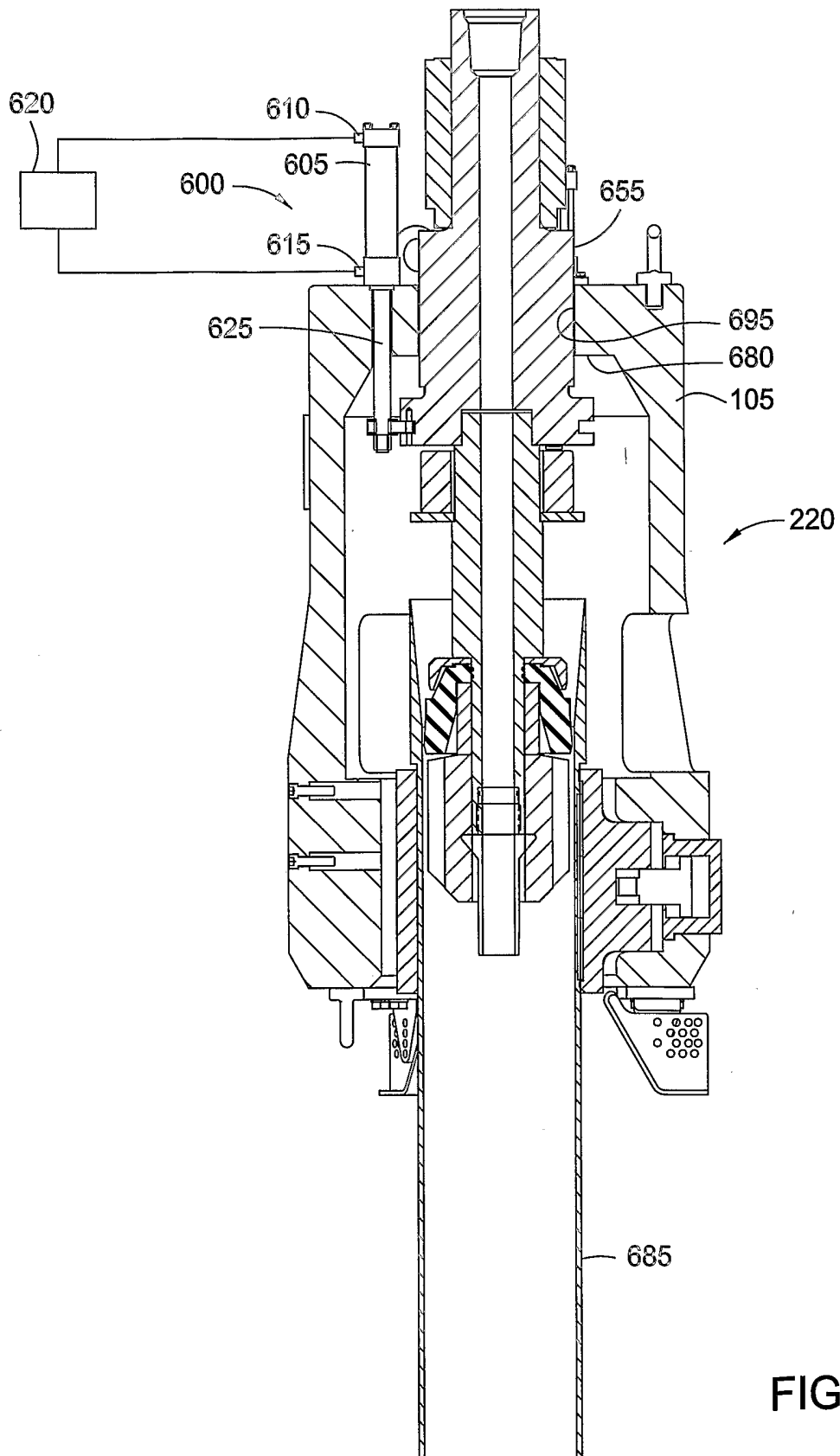

FIG. 13

11/17

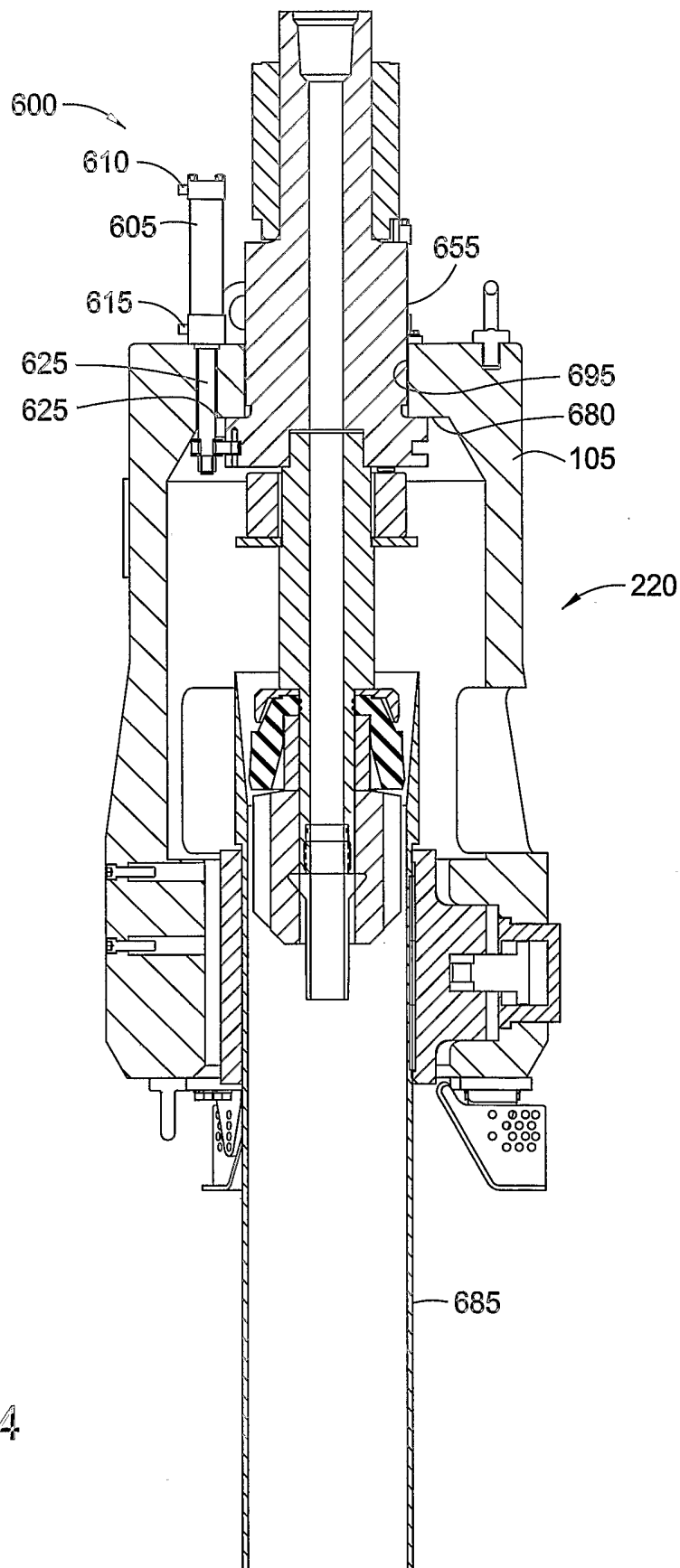

FIG. 14

12/17

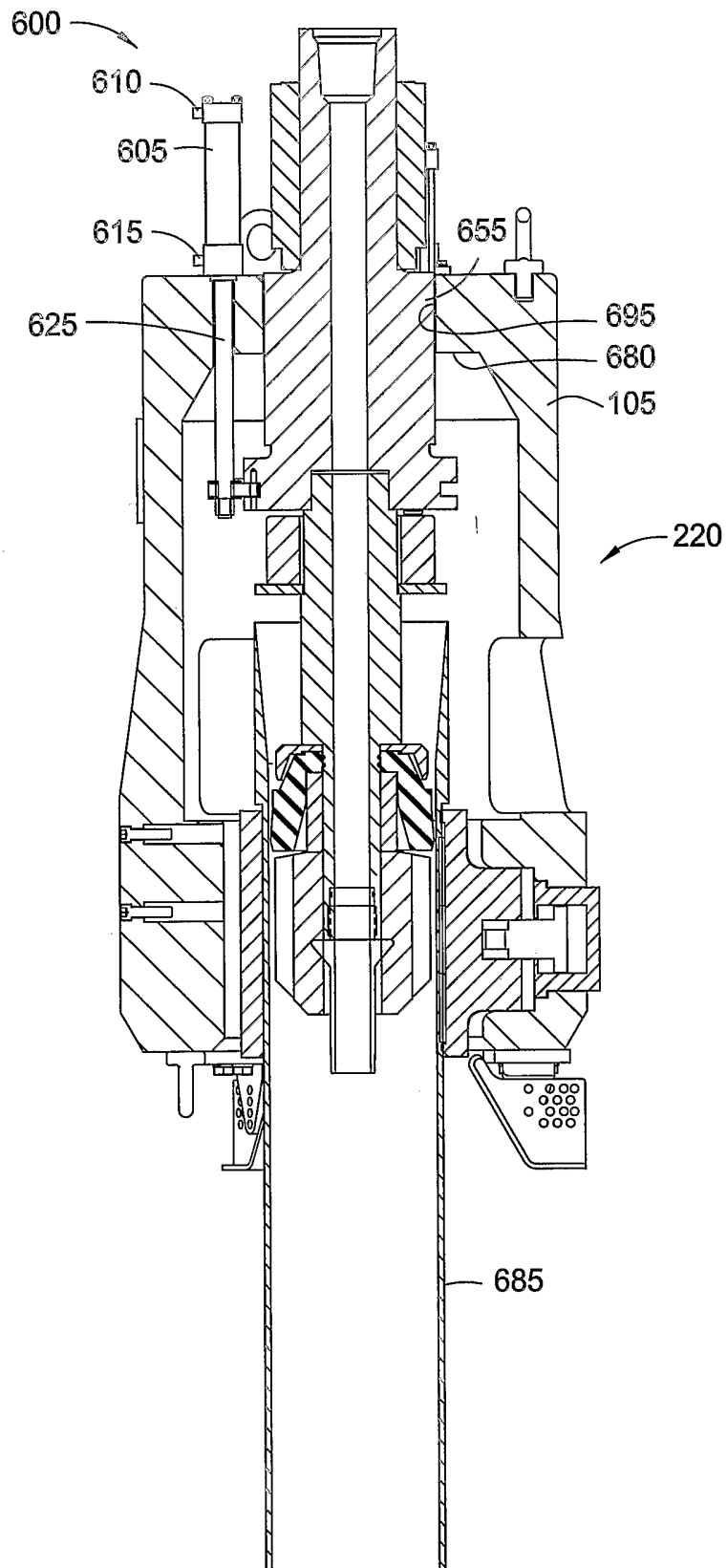
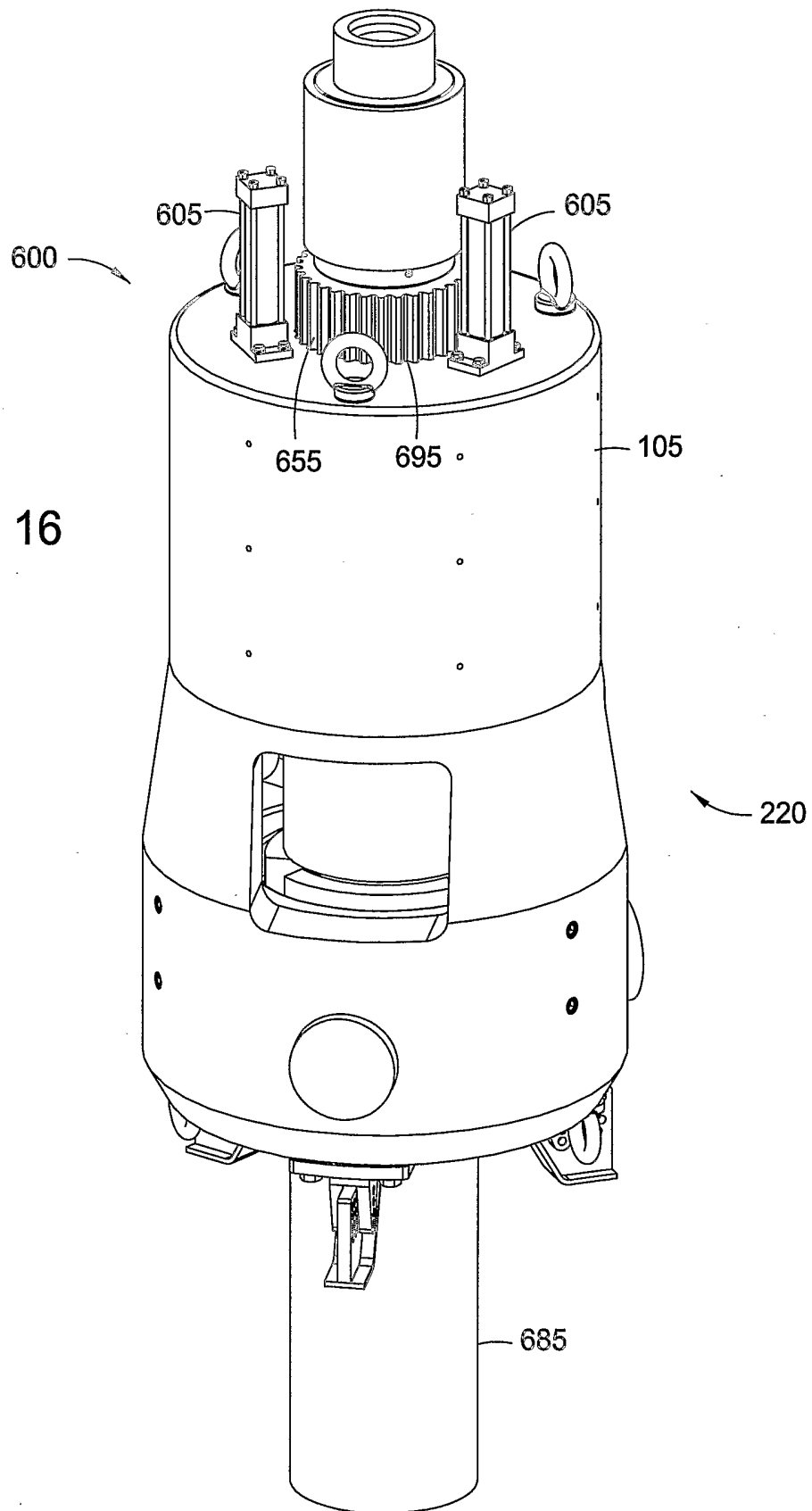

FIG. 15

13/17

FIG. 16



14/17

FIG. 17

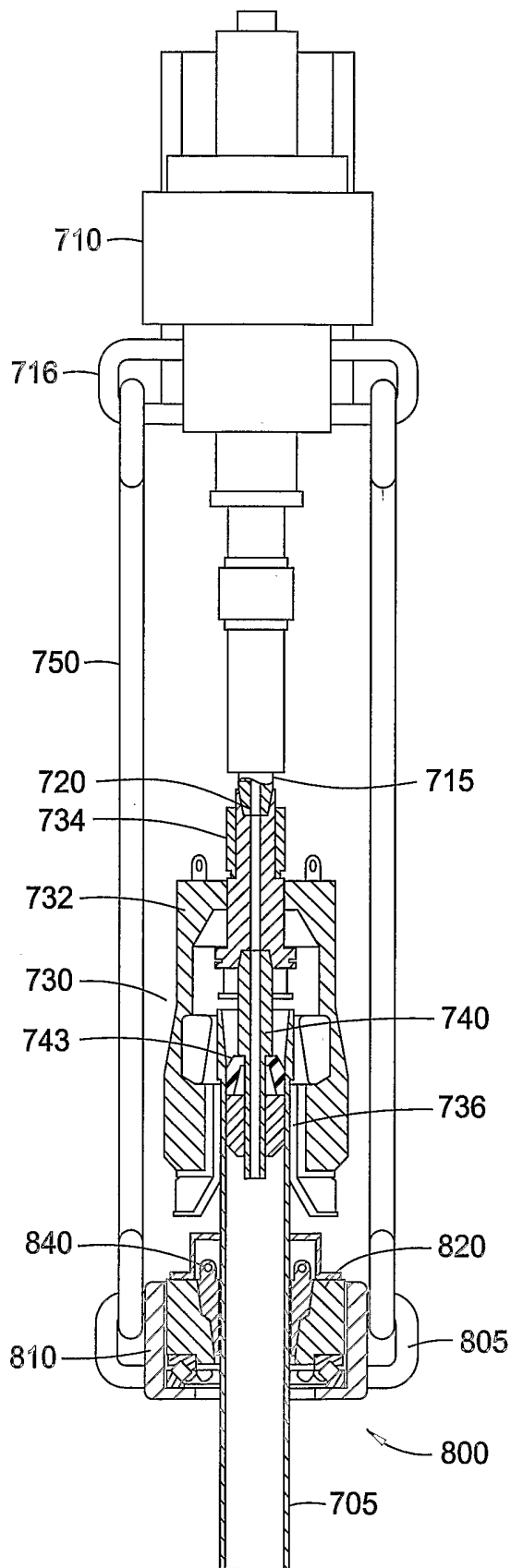

16/17

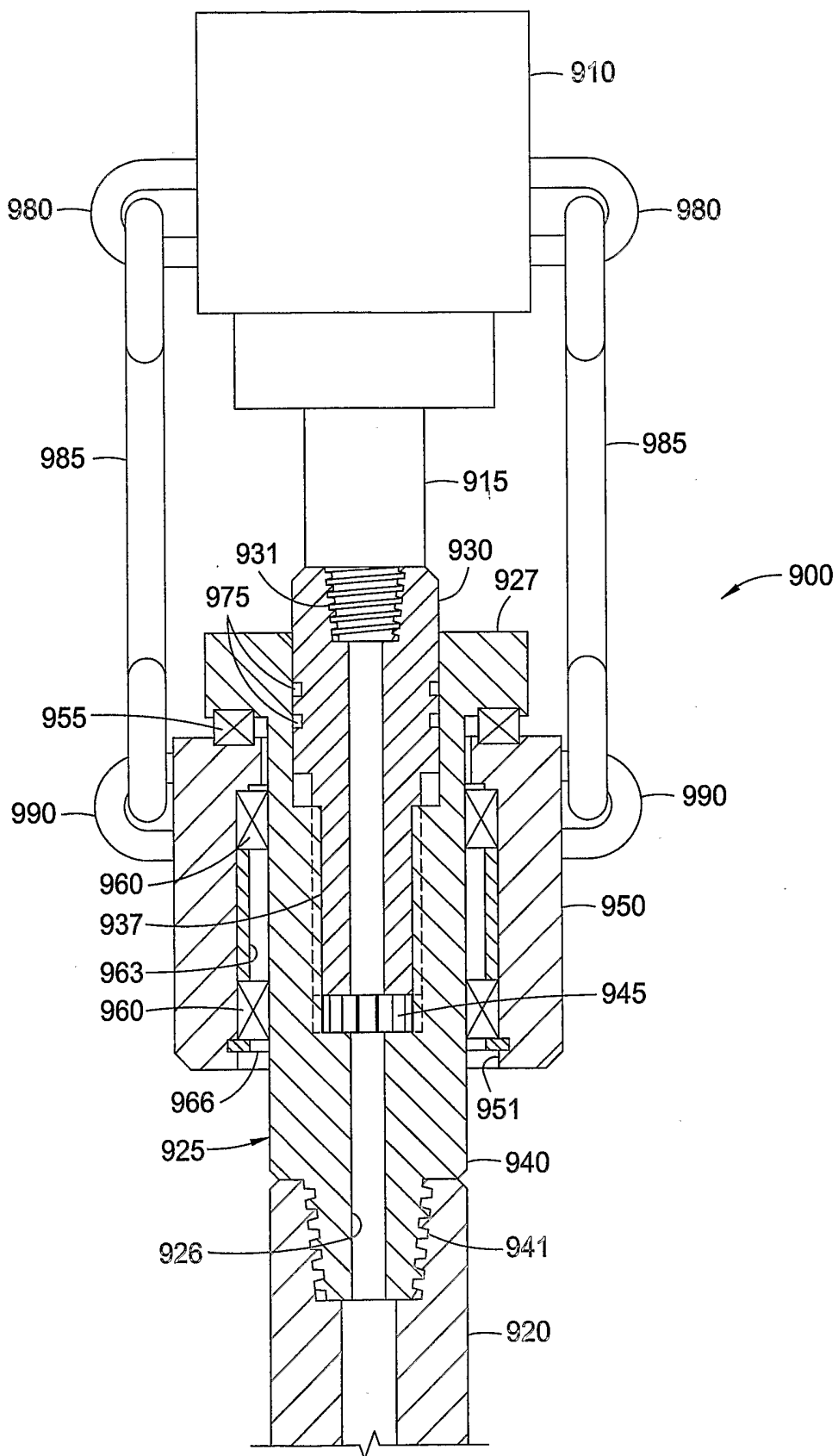

FIG. 19

17/17

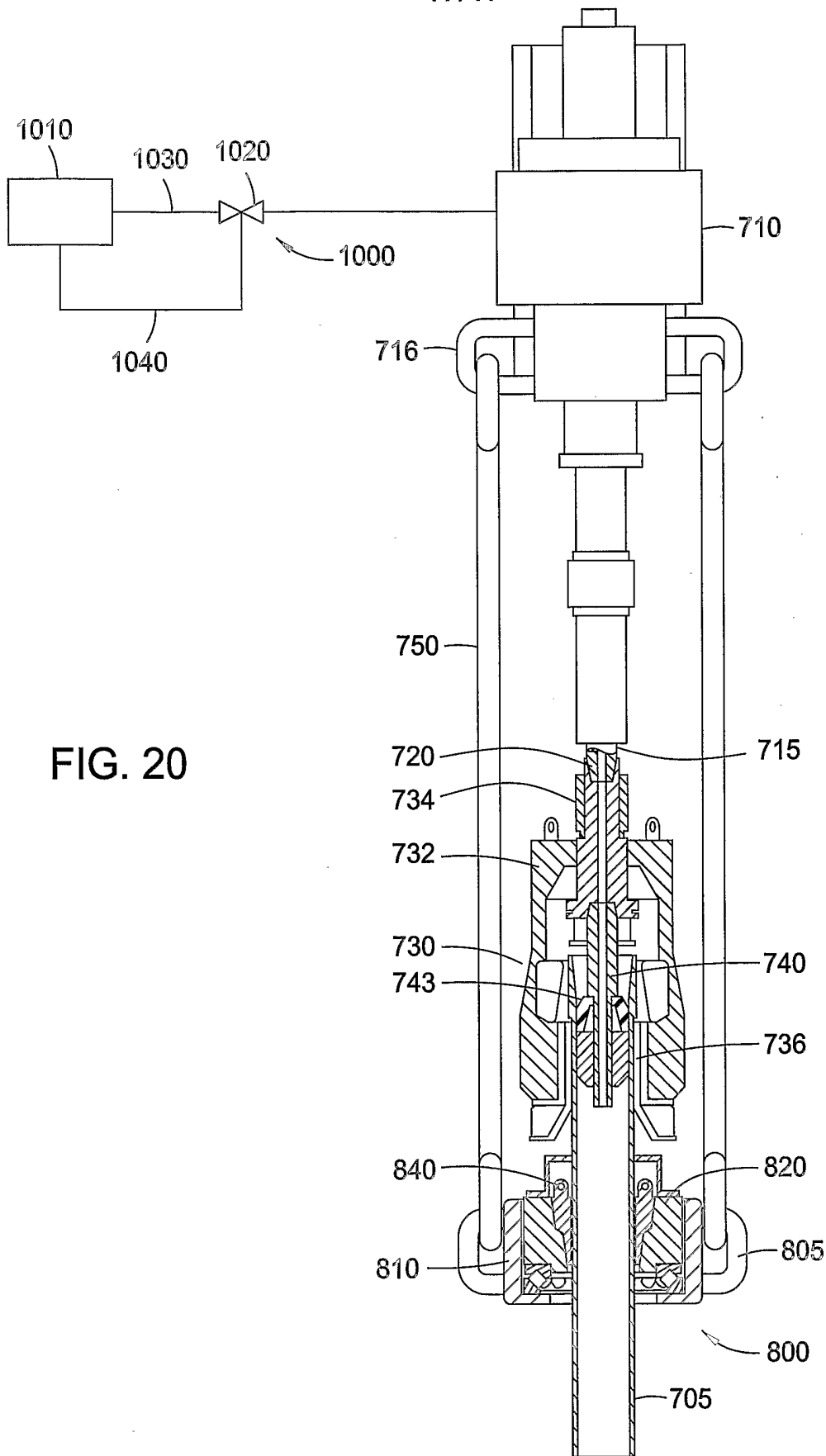

FIG. 20