

T. J. NEWLAND.
Locomotive Head Light.

No. 46,380.

Patented Feb. 14, 1865.

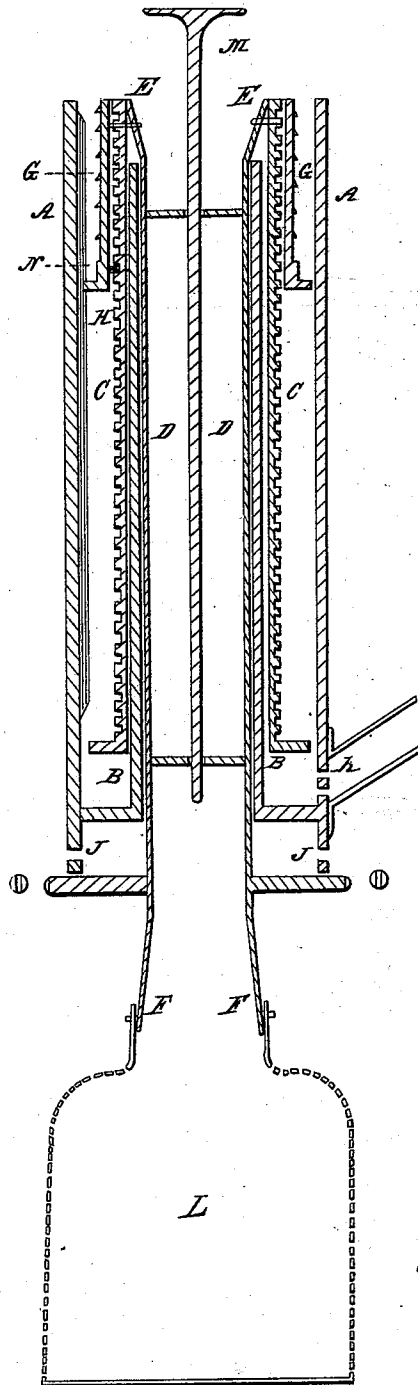

Witnesses:
Dexter Gillmar
B. F. French

Inventor:
Thos. Newland

UNITED STATES PATENT OFFICE.

THOMAS J. NEWLAND, OF UTICA, NEW YORK.

IMPROVEMENT IN LOCOMOTIVE HEAD-LIGHTS.

Specification forming part of Letters Patent No. 46,380, dated February 14, 1865.

To all whom it may concern:

Be it known that I, THOMAS J. NEWLAND, of Utica, Oneida county, New York, have invented a new and useful Improvement in Locomotive Head-Lights or Railroad-Lamps; and I do hereby declare that the following is a full, clear, and exact description of the same, reference being had to the annexed drawing, making a part of this specification, which drawing represents a sectional view of the burner containing said improvement.

The nature of my invention consists, first, in the use and arrangement of four tubes in the construction of the burner, by means of which the lamp is prevented from leaking and the wick is readily raised and lowered without its being caused to rotate, as in other cases where a screw is used; and, second, in making the inner tube bell shape at the top and bottom for the regulation of the air to the flame.

A A is the outer barrel of the wick-tube; B B, the inner one. C C is the screw, and D D the inner tube with the bell-shaped ends E E and F F. G G is the wick-thimble, and I a pin therein playing in the screw C C, and N is a notch in the flange of G, which plays on the way H, attached to the inner side of A.

O O is a milled ring attached to D for turning the screw C C. K is the feed-tube; I I, a circle of ventilating perforations. M is the button, and L a perforated cup to regulate the ingress of air to the center of the wick. The outer and inner barrels of the wick-tube, A A and B B, are of the ordinary form and are united together near the bottom by soldering them to an interposed ring, as seen at B B. Below this is the circle of holes J J, through A A, to keep cool the bottom of the burner. The inside cylinder or barrel, D D, is

beveled outward at both ends, as seen at E E and F F, and just at the bottom of A A is attached O O. C C is fitted close to B B, and has a screw on its outer surface, and is riveted firmly to D D at the top, as seen at E E. The wick-thimble G is of the usual form, and has a pin, I, on its inner side, which plays into the screw C, while the flange on G has a notch, N, which slides over the way H, attached longitudinally to the inside of A.

To raise or lower the wick, O O is turned, which causes C C to turn in the same direction, and as G cannot turn, by reason of the notch A and way H, it is forced to move up or down as O O may be turned by the screw C acting on the pin I.

The bell-shaped ends of D D permit the air to ascend more freely and to strike the flame nearer to the point of combustion than if the upper end was straight.

The advantages of this form of construction, in addition to that just stated, are, its simplicity and economy; the impossibility of oil escaping, except that which drips over the top of the burner, and the doing away with the necessity of rotating the wick, as is usual in other cases where the screw is used.

I claim—

1. The combination and arrangement of the barrels or cylinders A, B, C, and D, used and operating substantially in the manner and for the purpose mentioned.

2. The beveled ends of the inner cylinder, D, separately and in combination, used and operating substantially in the manner and for the purposes mentioned.

THOS. J. NEWLAND.

Witnesses:

DEXTER GILLMORE,
B. F. FRENCH.