



- (51) International Patent Classification:
A61B 17/34 (2006.01) A61B 18/14 (2006.01)
- (21) International Application Number:
PCT/US2015/039554
- (22) International Filing Date:
8 July 2015 (08.07.2015)
- (25) Filing Language: English
- (26) Publication Language: English
- (30) Priority Data:
62/024,747 15 July 2014 (15.07.2014) US
- (71) Applicant: BOSTON SCIENTIFIC SCIMED, INC.
[US/US]; One Scimed Place, Maple Grove, MN 55311-1566 (US).
- (72) Inventors: BENNING, Christopher, A.; 14 Downey Street, Hopkinton, MA 01748 (US). WHITNEY, Andrew, J.; 32 Grove Street, Douglas, MA 01516 (US). BANNON, Bryan; 40 Parkers Grove Lane, Duxbury, MA 02332 (US).
- (74) Agents: KAPLUN, Oleg, F. et al.; 150 Broadway, Suite 702, New York, NY 10038 (US).
- (81) Designated States (unless otherwise indicated, for every kind of national protection available): AE, AG, AL, AM, AO, AT, AU, AZ, BA, BB, BG, BH, BN, BR, BW, BY, BZ, CA, CH, CL, CN, CO, CR, CU, CZ, DE, DK, DM,

DO, DZ, EC, EE, EG, ES, FI, GB, GD, GE, GH, GM, GT, HN, HR, HU, ID, IL, IN, IR, IS, JP, KE, KG, KN, KP, KR, KZ, LA, LC, LK, LR, LS, LU, LY, MA, MD, ME, MG, MK, MN, MW, MX, MY, MZ, NA, NG, NI, NO, NZ, OM, PA, PE, PG, PH, PL, PT, QA, RO, RS, RU, RW, SA, SC, SD, SE, SG, SK, SL, SM, ST, SV, SY, TH, TJ, TM, TN, TR, TT, TZ, UA, UG, US, UZ, VC, VN, ZA, ZM, ZW.

(84) Designated States (unless otherwise indicated, for every kind of regional protection available): ARIPO (BW, GH, GM, KE, LR, LS, MW, MZ, NA, RW, SD, SL, ST, SZ, TZ, UG, ZM, ZW), Eurasian (AM, AZ, BY, KG, KZ, RU, TJ, TM), European (AL, AT, BE, BG, CH, CY, CZ, DE, DK, EE, ES, FI, FR, GB, GR, HR, HU, IE, IS, IT, LT, LU, LV, MC, MK, MT, NL, NO, PL, PT, RO, RS, SE, SI, SK, SM, TR), OAPI (BF, BJ, CF, CG, CI, CM, GA, GN, GQ, GW, KM, ML, MR, NE, SN, TD, TG).

Declarations under Rule 4.17:

- as to applicant's entitlement to apply for and be granted a patent (Rule 4.17(ii))
- as to the applicant's entitlement to claim the priority of the earlier application (Rule 4.17(iii))

Published:

- with international search report (Art. 21(3))



WO 2016/010787 A1

(54) Title: EUS GUIDED ACCESS DEVICE

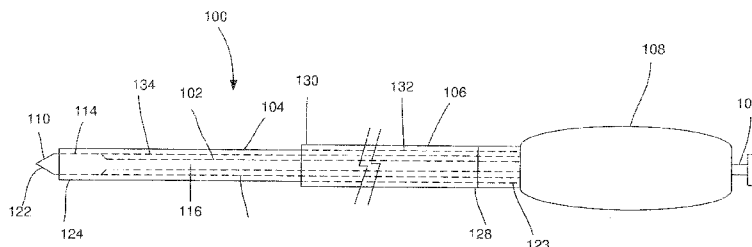

Fig. 1

(57) Abstract: A system (100) for endoscopic ultrasound guided drainage includes an access sheath (104) extending longitudinally from a proximal end to a distal end and including an access lumen extending therethrough from the proximal end to the distal end; a stylet (102) slidably received within the access lumen, the stylet (102) extending longitudinally from a proximal end to distal end and including a channel extending therethrough, the channel configured to receive a fluid therethrough; and a dilating sheath (106) extending longitudinally from a proximal end to a distal end and including a dilating lumen extending therethrough. The dilating lumen is sized and shaped to slidably receive the access sheath.

EUS GUIDED ACCESS DEVICE

5 Priority Claim

[0001] The present application claims priority to U.S. Provisional Patent Application Serial No. 62/024,747 filed July 15, 2014; the disclosure of which is incorporated herewith by reference.

Background

10 [0002] The pancreas and biliary system together form an important part of the digestive system. The pancreas and liver produce digestive fluids (pancreatic juice and bile) which help in the process of digestion (i.e., the breakdown of foods into parts which can be absorbed easily and used by the body). These digestive fluids are passed through the pancreatic duct and ducts of the biliary system prior to exiting into the intestine. Blockage of any of these ducts by, for example,
15 a cancer, gallstone or scarring, may result in the duct becoming backed up and filled with fluid, requiring drainage.

Summary

20 [0003] The present disclosure is directed to a system for endoscopic ultrasound guided drainage, comprising an access sheath extending longitudinally from a proximal end to a distal end and including an access lumen extending therethrough from the proximal end to the distal end, a stylet slidably received within the access lumen, the stylet extending longitudinally from a proximal end to distal end and including a channel extending therethrough, the channel configured to receive a fluid therethrough, and a dilating sheath extending longitudinally from a
25 proximal end to a distal end and including a dilating lumen extending therethrough, the dilating lumen sized and shaped to slidably receive the access sheath.

[0004] In an embodiment, the access sheath may include a distal portion biased toward a

curved configuration.

5 [0005] In an embodiment, the access sheath may be formed of a flexible polymeric material which permits the curved distal portion to be moved to a straightened configuration when the stylet is received therein.

[0006] In an embodiment, the curved configuration may be one of a pigtail loop, a J-shape and a shepherd's crook.

10 [0007] In an embodiment, the stylet may include a distal portion having a diameter larger than a remaining length of the stylet extending proximally from the distal portion.

[0008] In an embodiment, a portion of the channel extending through the distal portion of the stylet may be defined by an annular space extending about a longitudinal axis of the stylet.

15 [0009] In an embodiment, the system may further comprise a handle assembly coupled to a proximal end of each of the stylet, access sheath and dilating sheath.

20 [0010] In an embodiment, the handle assembly may include an actuator for moving the dilating sheath longitudinally relative to the access sheath.

[0011] In an embodiment, the dilating sheath may include an electrode at a distal end thereof configured to cauterize tissue.

25 [0012] In an embodiment, a distal portion of the stylet may have a larger diameter than a remaining portion of the stylet extending proximally therefrom, the diameter of the distal portion of the stylet corresponding to a diameter of the access lumen to facilitate puncturing of a target tissue.

[0013] In an embodiment, the system may further comprise a handle assembly coupled to a proximal end of each of the stylet, access sheath and dilating sheath.

5 [0014] In an embodiment, the handle assembly may include an actuator for moving the dilating sheath longitudinally relative to the access sheath.

[0015] The present disclosure is also directed to a method for endoscopic ultrasound guided drainage, comprising inserting an access sheath and a stylet through a working channel of an
10 endoscope into a target duct within a body, the stylet extending through a lumen of the access sheath such that a distal tip of the stylet extends distally past a distal end of the access sheath so that the distal tip punctures the target duct, injecting a contrast media through a channel of the stylet into the target duct to visually verify that the target duct is filled with fluids, and advancing a dilating sheath distally over the access sheath and into the target duct to dilate the target duct.

15

Brief Description of the Drawings

[0016] Fig. 1 shows a longitudinal cross-sectional view of a system according to an exemplary embodiment of the present disclosure;

20 Fig. 2 shows a longitudinal cross-sectional view of a distal portion of a stylet of the assembly of Fig. 1;

Fig. 3 shows a side view of an access sheath according to the system of Fig. 1;

25 Fig. 4 shows a side view of an access sheath according to another exemplary embodiment of the present disclosure;

Fig. 5 shows a side view of an access sheath according to yet another exemplary

embodiment of the present disclosure; and

Fig. 6 shows a perspective view of a handle assembly of the system of Fig. 1.

5 **Detailed Description**

[0017] The present disclosure may be further understood with reference to the following description and the appended drawings, wherein like elements are referred to with the same reference numerals. The present disclosure is directed to endoscopic medical devices and, in particular, relate to endoscopic ultrasound (EUS) guided drainage. Exemplary embodiments describe a EUS guided drainage systems comprising a stylet for injecting a fluid into a fluid-filled duct, an access sheath through which the stylet is inserted and a dilating sheath for dilating the fluid-filled duct to facilitate drainage. It will be understood by those of skill in the art that the system and method of the present disclosure may be used to drain, for example, a bile duct, a pancreatic duct, cysts, gallbladder, etc. It should be noted that the terms “proximal” and “distal” as used herein are intended to refer to a direction toward (proximal) and away from (distal) a user of the device.

[0018] As shown in Figs. 1 - 6, a system 100 according to an exemplary embodiment of the present disclosure comprises a stylet 102 for puncturing a fluid-filled tract and injecting a fluid (e.g., contrast media) therein and an access sheath 104 for providing access into the fluid-filled tract. The system 100 further comprises a dilating sheath 106 for dilating the tract to facilitate drainage. The system 100 is sized and shaped to be passed through a working channel of an endoscope to be visualized under ultrasound guidance. The system 100 may further comprise a handle assembly 108, which remains outside of a living body while the stylet 102 and the access sheath 104 are inserted therein (e.g., along a body lumen accessed via a naturally occurring body orifice). The handle assembly 108 permits the stylet 102 to be removed therefrom while the access sheath 104 remains in the target duct. The handle assembly 108 also includes an actuator for advancing the dilating sheath 106 over the access sheath 104 and into the target duct.

[0019] As shown in Fig. 2, a stylet 102 extends along a longitudinal axis from a proximal end 109 to a distal end 110 and includes a channel 112 extending therethrough. The stylet 102 may be formed of a flexible material so that the stylet 102 may be passed along tortuous paths, for example, along a natural body lumen. In one exemplary embodiment, the stylet 102 may be formed of nitinol for both flexibility and superelasticity. It will be understood by those of skill in the art, however, that the stylet 102 may be formed of any of a variety of flexible materials. The distal end 110 includes a tapered distal tip 122 for puncturing the target duct. A distal portion 114 of the stylet 102 may have a larger diameter than a proximal portion 116 of the stylet 102 extending proximally therefrom. A length of the distal portion 114 of the stylet 102 may range from between 0.3 cm and 5.0 cm, and, in particular, may be about 1 cm. A proximal portion 118 of the channel 112 extends through the proximal portion 116 of the stylet 102 along the longitudinal axis thereof while a distal portion 120 of the channel 112 extending through the distal portion 114 of the stylet 102 is defined by an annular space extending about the longitudinal axis of the stylet 102. A fluid such as, for example, a contrast media, may be injected into the target duct via the channel 112 to verify that the target duct is filled with fluid (e.g., digestive fluid).

[0020] As shown in Fig. 1, the access sheath 104 extends longitudinally from a proximal end 123 to a distal end 124 and includes a lumen 134 extending therethrough. The lumen 134 is sized and shaped to slidably receive the stylet 102 therein. In particular, an inner diameter of the lumen 134 in this embodiment substantially corresponds to an outer diameter of the distal portion 114 of the stylet 102 so that when the stylet 102 is received therein, the distal portion 114 completely fills the lumen 134 of the access sheath 104 to facilitate puncturing of the target duct when the access sheath 104, with the stylet 102 received therein, is inserted into the target duct. As shown in Fig. 3, the access sheath 104 may be biased to assume a desired curvature along a distal portion 126 thereof. In one exemplary embodiment, the distal portion 126 of the access sheath 104 is biased toward a pigtail configuration particularly suited for stabilizing the access sheath 104 in the target duct. In another exemplary embodiment, as shown in Fig. 4, a distal

portion 126' of an access sheath 104' has a shepherd's crook configuration (i.e., a curve which directs the distal end of the sheath 104' back toward more proximal portions thereof) particularly suited for directing a guidewire in a desired direction within the target duct. In yet another exemplary embodiment, as shown in Fig. 5, a distal portion 126" of an access sheath 104" is
5 biased toward a J-shaped configuration (i.e., a curve in which the distal portion 126" arcs away from an axis of more proximal portions of the sheath 104" along an arc of 90° or less) for directing a guidewire in another desired direction in the target duct.

[0021] The access sheath 104 may be formed of a polymeric material that is sufficiently
10 flexible so that when the stylet 102 is received therein, the distal portion 126 of the access sheath 104 is straightened. Once the stylet 102 is removed therefrom, however, the distal portion 126 of the access sheath 104 is permitted to revert to its curved configuration. In an exemplary embodiment, the access sheath 104 is formed of braid reinforced polyamide. In another embodiment, the access sheath 104 is formed of multiple layers such as, for example, PTFE,
15 braids, polyether block amide for kink resistance.

[0022] The dilating sheath 106 similarly extends longitudinally from a proximal end 128 to a distal end 130 and includes a lumen 132 extending therethrough. The lumen 132 is sized and shaped to slidably receive the access sheath 104 therein so that the dilating sheath 106 may be
20 advanced over the access sheath 104 to the target duct to dilate the obstructed duct, thereby facilitating drainage thereof. The dilating sheath 106 may be a cold dilator such as, for example, a sohendra type dilator and/or a balloon dilator. Alternatively, the dilating sheath 106 may be a hot dilator such as, for example, a cystome or needleknife, which includes electrosurgical capabilities. For example, the dilating sheath 106 may include an electrode along the distal end
25 130 thereof for cauterizing tissue. In particular, the dilating sheath 106 may be configured to utilize electrosurgical dissection to facilitate dilation or to burn a lesion as the dilating sheath 106 is inserted into the target duct. In embodiments in which the dilating sheath 106 includes an electrode, the sheath 106 may include a second lumen (not shown) extending therethrough for

carrying power to the electrode. The distal end 130 of the dilating sheath 106, however, may have any of a variety of configurations facilitating insertion into the target duct. In another example, the distal end 130 may be tapered. Once the dilating sheath 106 is advanced over the access sheath 104 and inserted into the target duct, the dilating sheath 106 may be actuated to dilate or expand the target duct. For example, the dilating sheath 106 may have one or more stepped diameters at discrete distances from the distal end or one or more additional sheaths that may be independently actuated to expand the path to the target duct.

[0023] As shown in Fig. 6, the handle assembly 108 includes a grip portion 136 extending from a proximal end 138 to a distal end 140 and an extension portion 142 coupled to the distal end 140 of the grip portion 136 and couplable to the proximal end 128 of the dilating sheath 106. The access sheath 104 may be received within and coupled to the grip portion 136 such that the access sheath 104 extends through the lumen 132 of the dilating sheath 106. The stylet 102 extends through the grip portion 136 and the extension portion 142 with the proximal end of the stylet 102 extending proximally of the proximal end 138 of the grip portion and length of the stylet 102 extending through the lumen 134 of the access sheath 104. Since the proximal end 109 of the stylet 102 extends proximally from the grip portion 136, the stylet 102 may be removed from the access sheath 104 by simply pulling the stylet 102 proximally relative to the handle assembly 108. The distal end 110 of the stylet 102 extends distally past the distal end 124 of the access sheath 104 so that the tapered tip 122 may puncture the target duct once the system 100 has been inserted into the body. The handle assembly 108 also includes an actuator 144 which moves the dilating sheath 106 longitudinally relative to the access sheath 104. In particular, the actuator 144 may include a tab that is moved distally and proximally with respect to the grip portion 136 of the handle assembly 108 to advance and retract, respectively, the dilating sheath 106 over the access sheath 104.

[0024] According to a method using the system 100 according to an exemplary embodiment of the present disclosure, the system 100 is inserted through a working channel of an endoscope via

ultrasound guidance to a target duct within the body. In an insertion configuration, the access sheath 104 may be fully housed within the dilating sheath 106 to protect the endoscope through which the system 100 is inserted from the sharp distal tip 122 of the stylet 102. Upon insertion through the endoscope, the dilating sheath 106 may be retracted so that the dilating sheath 106 does not extend over the portion of the access sheath 104 being inserted into the target duct. At this point, the distal end 110 of the stylet 102 extends distally past the distal end 124 of the access sheath 104. The distal tip 122 of the stylet 102 is then advanced distally to penetrate the target duct. Once the stylet 102 and the access sheath 104 have been inserted into the target duct, a contrast media (e.g., radiopaque dye) is inserted through the channel 112 of the stylet 102 into the target duct so that a user of the system 100 may visually verify that the duct has been filled with fluid and requires drainage. The stylet 102 may then be removed from the access sheath 104 by drawing the stylet 102 proximally relative to the access sheath 104 so that only the access sheath 104 remains in the target duct. Upon removal of the stylet 102, the distal portion 126 of the access sheath 104 is freed to revert to the curved configuration to either anchor the access sheath 104 in the target duct or to direct a guidewire therethrough in a desired direction. If the access sheath 104 is not anchored in the target duct, a guidewire may be inserted through the lumen 134 of the access sheath 104 and into the target duct. A tip of the guidewire is directed in a direction corresponding to a curvature of the distal portion 126 of the access sheath 104 to contact an interior surface of the target duct to anchor the access sheath 104 thereto. The access sheath 104 may be rotated by manipulating a portion of the handle assembly 108 to direct the curved configuration in a desired direction.

[0025] Once the access sheath 104 has been anchored in the target duct, the dilating sheath 106 is advanced over the access sheath 104 into the target duct. As described above, the dilating sheath 106 is advanced by moving the actuator 144 distally with respect to the grip portion 136 of the handle assembly 108. The distal end 130 of the dilating sheath 106 is configured to facilitate insertion of the dilating sheath 106 into the target duct. In one embodiment, an electrode at the distal end 130 is activated to electrosurgically dissect and/or cauterize a surface

tissue of the target duct to facilitate insertion therein. The dilating sheath 106 may be activated to dilate the target duct, enlarging the duct beyond an obstruction thereof to permit drainage of the target duct. It will be understood by those of skill in the art that the dilating sheath 106 may dilate the target duct in any of a number of ways. In one example, the dilating sheath 106 may include an expansible balloon activated to expand the target duct. It will be understood by those
5 of skill in the art that a user may also implement further treatment of the blocked duct. In particular, a stent may be inserted into the target into the target duct, maintaining the duct in an enlarged configuration to ensure continued drainage thereof.

10 **[0026]** It will be apparent to those skilled in the art that various modifications may be made in the present disclosure, without departing from the scope of the disclosure. Thus, it is intended that the present disclosure cover the modifications and variations of his disclosure provided that they come within the scope of the appended claims and their equivalents.

What is claimed is:

1. A system for endoscopic ultrasound guided drainage, comprising:
an access sheath extending longitudinally from a proximal end to a distal end and
5 including an access lumen extending therethrough from the proximal end to the distal end;
a stylet slidably received within the access lumen, the stylet extending longitudinally from
a proximal end to distal end and including a channel extending therethrough, the channel
configured to receive a fluid therethrough; and
a dilating sheath extending longitudinally from a proximal end to a distal end and
10 including a dilating lumen extending therethrough, the dilating lumen sized and shaped to
slidably receive the access sheath.
2. The system of claim 1, wherein the access sheath includes a distal portion biased toward a
curved configuration.
- 15 3. The system of claim 2, wherein the access sheath is formed of a flexible polymeric
material which permits the curved distal portion to be moved to a straightened
configuration when the stylet is received therein.
- 20 4. The system of either of claims 2 and 3, wherein the curved configuration is one of a
pigtail loop, a J-shape and a shepherd's crook.
5. The system of any of claims 1 to 4, wherein the stylet includes a distal portion having a
diameter larger than a remaining length of the stylet extending proximally from the distal
25 portion.
6. The system of any one of claims 1 to 5, wherein a portion of the channel extending
through the distal portion of the stylet is defined by an annular space extending about a

longitudinal axis of the stylet.

- 5
7. The system of any one of claims 1 to 6, further comprising a handle assembly coupled to a proximal end of each of the stylet, access sheath and dilating sheath.
8. The system of claim 7, wherein the handle assembly includes an actuator for moving the dilating sheath longitudinally relative to the access sheath.
- 10
9. The system of any one of claims 1 to 8, the dilating sheath including an electrode at a distal end thereof configured to cauterize tissue.
- 15
10. The system of any one of claims 1 to 9, a distal portion of the stylet has a larger diameter than a remaining portion of the stylet extending proximally therefrom, the diameter of the distal portion of the stylet corresponding to a diameter of the access lumen to facilitate puncturing of a target tissue.
- 20
11. The system of any one of claims 1 to 10, further comprising a handle assembly coupled to a proximal end of each of the stylet, access sheath and dilating sheath.
- 25
12. The system of claim 11, wherein the handle assembly includes an actuator for moving the dilating sheath longitudinally relative to the access sheath.
13. A system for endoscopic drainage, comprising:
an access sheath extending longitudinally from a proximal end to a distal end and
including an access lumen extending therethrough from the proximal end to the distal end;
a stylet slidably received within the access lumen, the stylet extending longitudinally from a proximal end to distal tip and including a channel extending therethrough, the channel configured to receive a fluid therethrough, a distal portion of the stylet having a larger diameter

than a remaining portion of the stylet extending proximally therefrom, the diameter of the distal portion of the stylet corresponding to a diameter of the access lumen to facilitate puncturing of a target tissue; and

5 a dilating sheath extending longitudinally from a proximal end to a distal end and including a dilating lumen extending therethrough, the dilating lumen sized and shaped to slidably receive the access sheath.

14. The system of claim 13, wherein the access sheath includes a distal portion biased toward a curved configuration.

10

15. The system of claim 14, wherein the access sheath is formed of a flexible polymeric material which permits the curved distal portion to be moved to a straightened configuration when the stylet is received therein.

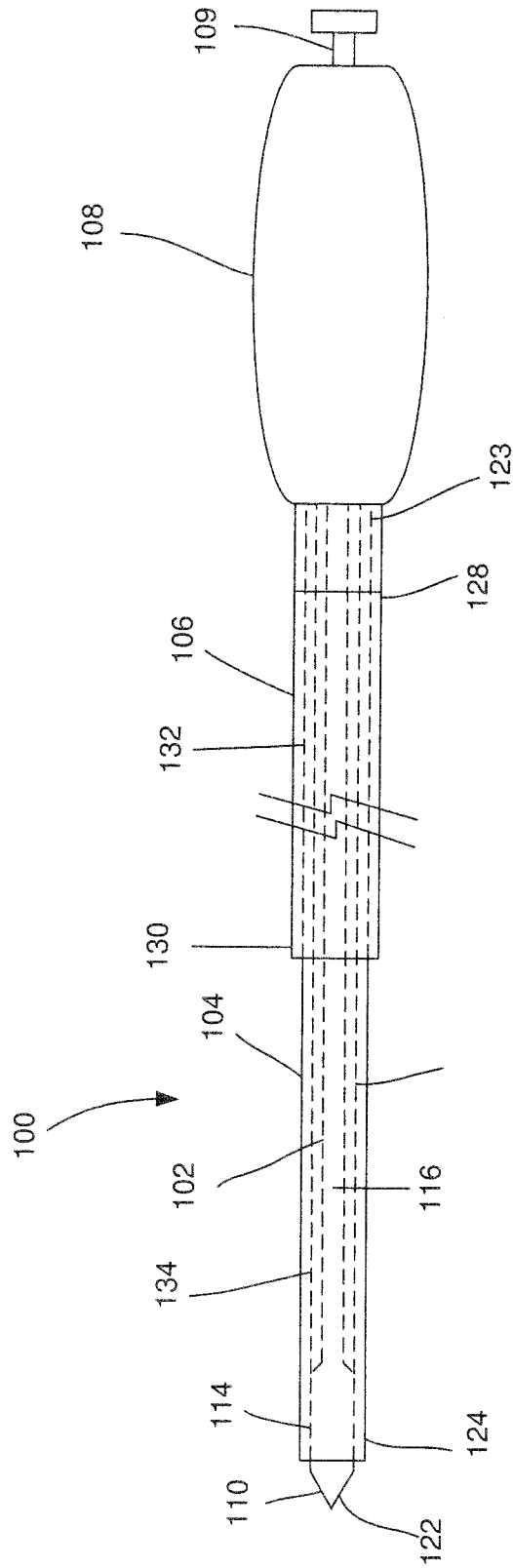

Fig. 1

2 / 4

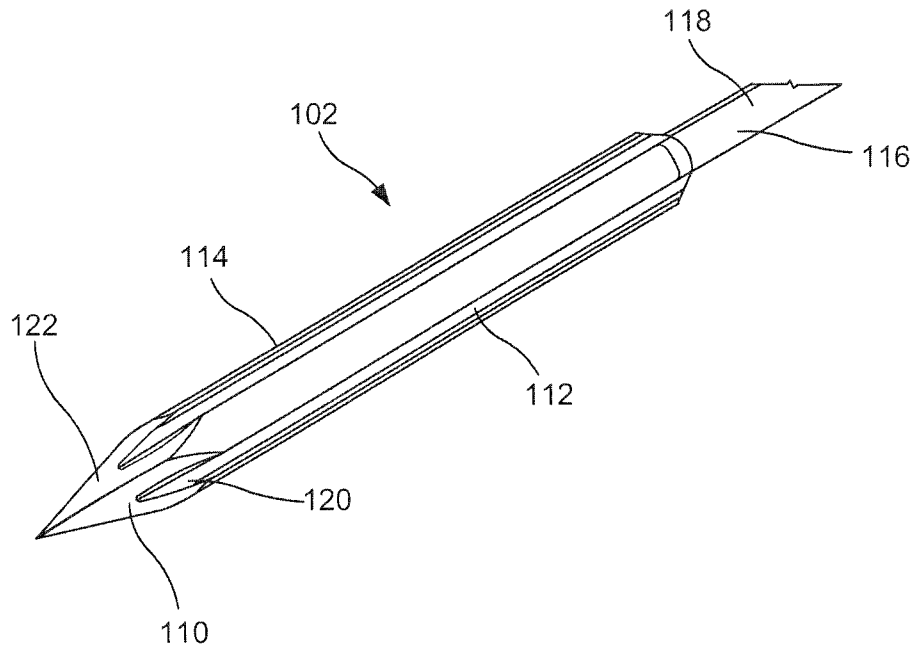

FIG. 2

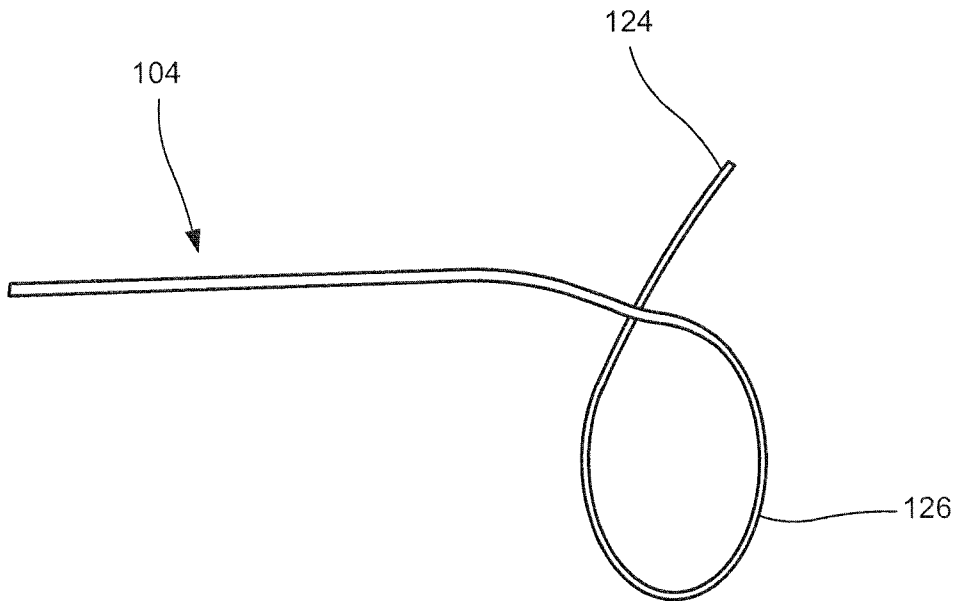

FIG. 3

3 / 4

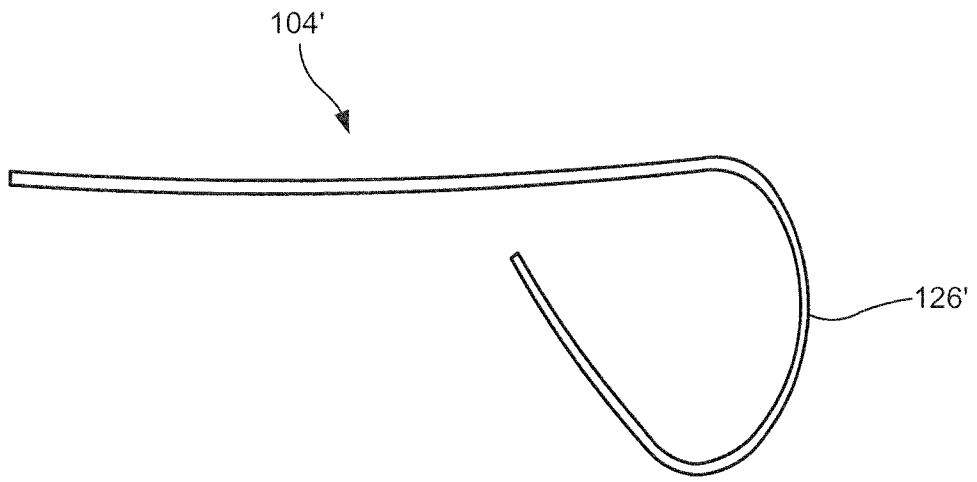

FIG. 4

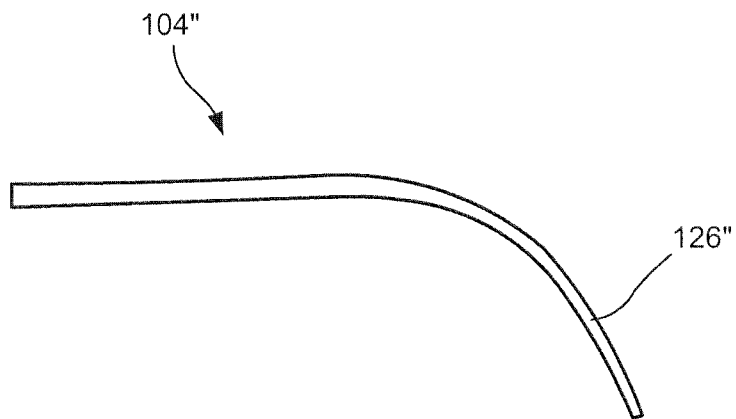

FIG. 5

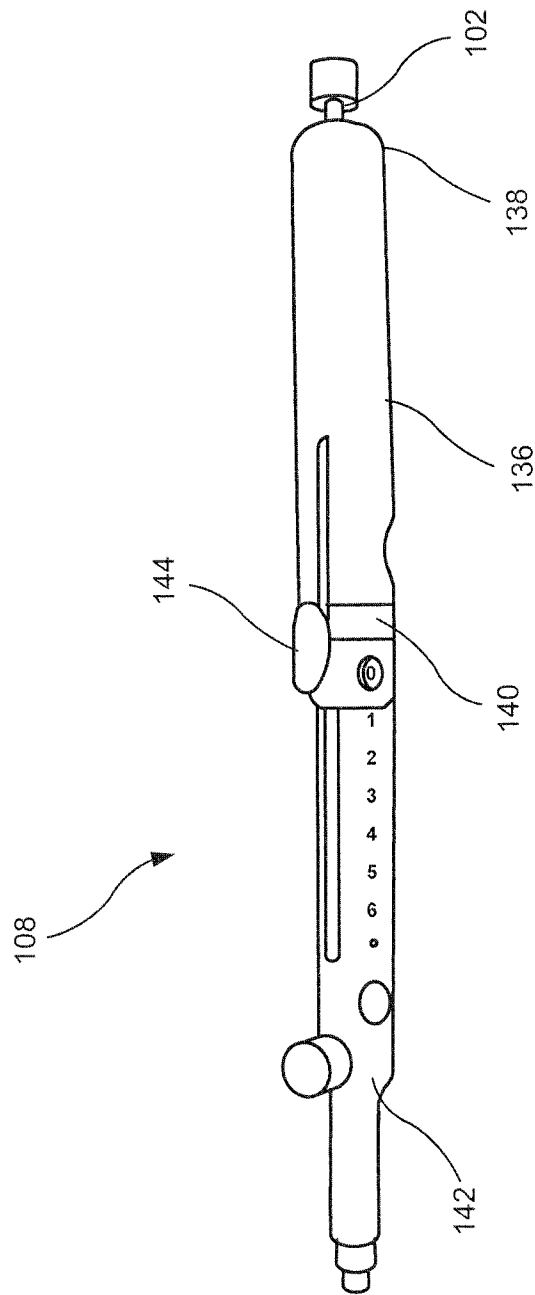

FIG. 6

INTERNATIONAL SEARCH REPORT

International application No
PCT/US2015/039554

A. CLASSIFICATION OF SUBJECT MATTER
INV. A61B17/34 A61B18/14
ADD.
According to International Patent Classification (IPC) or to both national classification and IPC

B. FIELDS SEARCHED
Minimum documentation searched (classification system followed by classification symbols)
A61B

Documentation searched other than minimum documentation to the extent that such documents are included in the fields searched

Electronic data base consulted during the international search (name of data base and, where practicable, search terms used)
EPO-Internal, WPI Data

C. DOCUMENTS CONSIDERED TO BE RELEVANT

Category*	Citation of document, with indication, where appropriate, of the relevant passages	Relevant to claim No.
Y	US 2013/090654 A1 (CLANCY MICHAEL S [IE]) 11 April 2013 (2013-04-11) paragraph [0014] - paragraph [0019]; figure 1	1-15
Y	----- US 2 256 942 A (JAMES DUFFY JOHN) 23 September 1941 (1941-09-23) page 3, column 1, line 36 - line 56; figure 1	1-15
A	----- US 2014/005478 A1 (KENNEDY II KENNETH C [US] ET AL) 2 January 2014 (2014-01-02) paragraph [0019] - paragraph [0033]; figures 1-4	1-4,7, 11-15
	----- -/--	

Further documents are listed in the continuation of Box C.

See patent family annex.

* Special categories of cited documents :

"A" document defining the general state of the art which is not considered to be of particular relevance

"E" earlier application or patent but published on or after the international filing date

"L" document which may throw doubts on priority claim(s) or which is cited to establish the publication date of another citation or other special reason (as specified)

"O" document referring to an oral disclosure, use, exhibition or other means

"P" document published prior to the international filing date but later than the priority date claimed

"T" later document published after the international filing date or priority date and not in conflict with the application but cited to understand the principle or theory underlying the invention

"X" document of particular relevance; the claimed invention cannot be considered novel or cannot be considered to involve an inventive step when the document is taken alone

"Y" document of particular relevance; the claimed invention cannot be considered to involve an inventive step when the document is combined with one or more other such documents, such combination being obvious to a person skilled in the art

"&" document member of the same patent family

Date of the actual completion of the international search 6 October 2015	Date of mailing of the international search report 14/10/2015
---	--

Name and mailing address of the ISA/ European Patent Office, P.B. 5818 Patentlaan 2 NL - 2280 HV Rijswijk Tel. (+31-70) 340-2040, Fax: (+31-70) 340-3016	Authorized officer Moers, Roelof
--	---

INTERNATIONAL SEARCH REPORT

International application No
PCT/US2015/039554

C(Continuation). DOCUMENTS CONSIDERED TO BE RELEVANT		
Category*	Citation of document, with indication, where appropriate, of the relevant passages	Relevant to claim No.
A	US 2006/135963 A1 (KICK GEORGE F [US] ET AL) 22 June 2006 (2006-06-22) paragraph [0061] - paragraph [0062]; figure 5	1,13
A	----- US 2005/059890 A1 (DEAL STEPHEN E [US] ET AL) 17 March 2005 (2005-03-17) paragraph [0122]; figures 41, 42	1-4, 13-15
A	----- US 2007/112302 A1 (YU CHUN H [HK]) 17 May 2007 (2007-05-17) paragraph [0053] - paragraph [0066]; figures 1-10	1-15
A	----- US 2010/081965 A1 (MUGAN JOHN [IE] ET AL) 1 April 2010 (2010-04-01) paragraph [0085]; figure 18 -----	5,13

INTERNATIONAL SEARCH REPORT

Information on patent family members

International application No PCT/US2015/039554

Patent document cited in search report	Publication date	Patent family member(s)	Publication date
US 2013090654	A1	11-04-2013	US 2013090654 A1 11-04-2013 WO 2013055543 A1 18-04-2013

US 2256942	A	23-09-1941	NONE

US 2014005478	A1	02-01-2014	AU 2013287085 A1 22-01-2015 EP 2866676 A1 06-05-2015 US 2014005478 A1 02-01-2014 WO 2014008035 A1 09-01-2014

US 2006135963	A1	22-06-2006	US 2006135963 A1 22-06-2006 WO 2006031596 A2 23-03-2006

US 2005059890	A1	17-03-2005	EP 1653884 A1 10-05-2006 EP 1660164 A1 31-05-2006 EP 1660165 A1 31-05-2006 JP 4611301 B2 12-01-2011 JP 4778425 B2 21-09-2011 JP 4898985 B2 21-03-2012 JP 2007500553 A 18-01-2007 JP 2007500554 A 18-01-2007 JP 2007500555 A 18-01-2007 US 2005059890 A1 17-03-2005 US 2005059990 A1 17-03-2005 US 2005070794 A1 31-03-2005 US 2005070821 A1 31-03-2005 US 2011087234 A1 14-04-2011 WO 2005011530 A1 10-02-2005 WO 2005011788 A1 10-02-2005 WO 2005011790 A1 10-02-2005

US 2007112302	A1	17-05-2007	CN 201271282 Y 15-07-2009 EP 1948046 A1 30-07-2008 HK 1119361 A2 27-02-2009 US 2007112302 A1 17-05-2007 US 2010004622 A1 07-01-2010 WO 2007056945 A1 24-05-2007

US 2010081965	A1	01-04-2010	CA 2739391 A1 08-04-2010 EP 2364111 A2 14-09-2011 JP 5755564 B2 29-07-2015 JP 2012504469 A 23-02-2012 JP 2015107324 A 11-06-2015 US 2010081965 A1 01-04-2010 WO 2010039955 A2 08-04-2010
