



(51) International Patent Classification:

*E21D 11/05* (2006.01)      *F16B 43/00* (2006.01)  
*E21D 11/38* (2006.01)      *E21D 21/00* (2006.01)  
*F16B 5/02* (2006.01)

(21) International Application Number:

PCT/NO2023/060104

(22) International Filing Date:

24 November 2023 (24.11.2023)

(25) Filing Language:

English

(26) Publication Language:

English

(30) Priority Data:

20221264      24 November 2022 (24.11.2022) NO

(71) Applicant: JOHN OLDROYD CHEETHAM [NO/NO];

Hasselstien 2, 3924 Porsgrunn (NO).

(72) Inventor: OLDROYD CHEETHAM, John; Hasselstien

2, 3924 Porsgrunn (NO).

(74) Agent: ACAPO AS; Edvard Griegs vei 1, 5059 Bergen

(NO).

(81) Designated States (unless otherwise indicated, for every kind of national protection available):

AE, AG, AL, AM, AO, AT, AU, AZ, BA, BB, BG, BH, BN, BR, BW, BY, BZ, CA, CH, CL, CN, CO, CR, CU, CV, CZ, DE, DJ, DK, DM, DO, DZ, EC, EE, EG, ES, FI, GB, GD, GE, GH, GM, GT, HN, HR, HU, ID, IL, IN, IQ, IR, IS, IT, JM, JO, JP, KE, KG, KH, KN, KP, KR, KW, KZ, LA, LC, LK, LR, LS, LU, LY, MA, MD, MG, MK, MN, MU, MW, MX, MY, MZ, NA, NG, NI, NO, NZ, OM, PA, PE, PG, PH, PL, PT, QA, RO, RS, RU, RW, SA, SC, SD, SE, SG, SK, SL, ST, SV, SY, TH, TJ, TM, TN, TR, TT, TZ, UA, UG, US, UZ, VC, VN, WS, ZA, ZM, ZW.

(54) Title: A SYSTEM FOR FIXING AND SEALING A LINING PROVIDING A FLUID TIGHT SUSPENSION OF A MEMBRANE ON TUNNEL WALLS

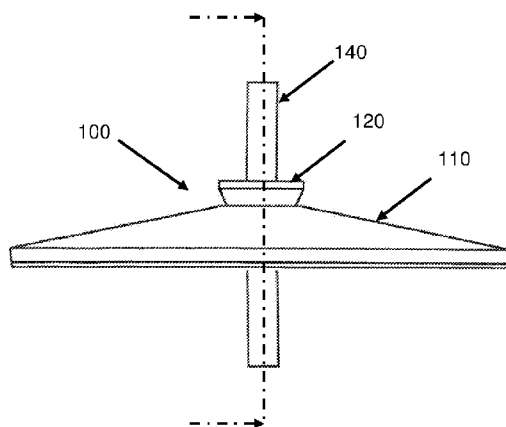

Fig. 3a

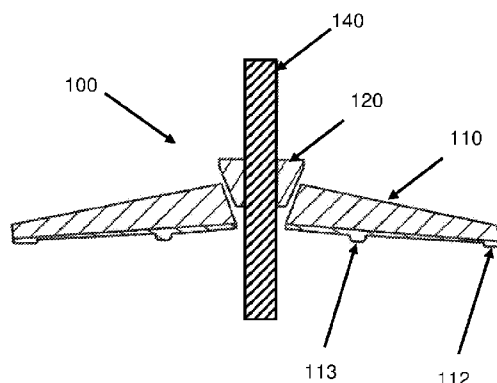

Fig. 3b

(57) Abstract: This document describe a system (100) for sealed attachment and support of a lining, membrane or PE foam (130) to a supporting surface (170), being tunnel or rock walls or ceilings, the lining, membrane or PE foam (130) is intended to be fixed to the supporting surface (170) by a plurality of bolts (140) fixed in the supporting surface (170) The system (100) comprises a disc (110) for threading onto the bolt (140), with a seal (112, 113) providing a sealing surface towards the lining (130). The seal (112, 113) forms an integrated unit with the disc (110) and only protrudes out at one side of the disc (110). The system further comprises a gasket (120) for threading onto the bolt providing locking and a sealing surface around said bolt (140), said gasket has a chamfered outer surface (122) for wedging into a centrally arranged through hole of the disc (110).



**(84) Designated States** (*unless otherwise indicated, for every kind of regional protection available*): ARIPO (BW, CV, GH, GM, KE, LR, LS, MW, MZ, NA, RW, SC, SD, SL, ST, SZ, TZ, UG, ZM, ZW), Eurasian (AM, AZ, BY, KG, KZ, RU, TJ, TM), European (AL, AT, BE, BG, CH, CY, CZ, DE, DK, EE, ES, FI, FR, GB, GR, HR, HU, IE, IS, IT, LT, LU, LV, MC, ME, MK, MT, NL, NO, PL, PT, RO, RS, SE, SI, SK, SM, TR), OAPI (BF, BJ, CF, CG, CI, CM, GA, GN, GQ, GW, KM, ML, MR, NE, SN, TD, TG).

**Published:**

- *with international search report (Art. 21(3))*
- *in black and white; the international application as filed contained color or greyscale and is available for download from PATENTSCOPE*

## A SYSTEM FOR FIXING AND SEALING A LINING PROVIDING A FLUID TIGHT SUSPENSION OF A MEMBRANE ON TUNNEL WALLS

### Field of the invention

5 The invention relates to a system for sealed attachment and support of a lining, membrane or PE foam intended to be fixed to a supporting surface, such as the walls and ceiling of a tunnel, also providing a watertight sealing of perforations in a water and frost protection material, such as lining or insulation in a tunnel/rock as further described in the preamble of the independent claims.

10

### Background of the invention

In tunnels, on rock walls and similar, there is a need for preventing intrusion of water into the tunnel from the surrounding rock formations. Moreover, there is a need for preventing formation of ice on the inner surface of the lining, i.e. the surface facing  
15 the tunnel room, and possibly also for provision of fire protection of the tunnel walls and the ceiling.

Water is leaking out of the rock walls, and during winter seasons, this water also tends to freeze, causing ice masses/icicles hazards. For prevention of such hazard,  
20 linings or membranes are widely used before covering the lining with a layer of shotcrete or installing concrete elements. Proper water and frost proofing is a cost-efficient way to extend service life of tunnels, but also to ensure safety of the tunnel both due to accumulation of cracks and/or icicles caused by freezing water.

25 In order to reduce such hazards where bits of concrete and/or ice may fall down, but also to prevent damage on installed equipment, intrusion of water, frozen road surface or fog, it is known to arrange a watertight and possibly insulating lining or protection on tunnel walls and/or ceilings. The lining or membrane is affixed to the wall and ceiling by means of rock anchor bolts, rigidly fixed to the wall and ceiling of  
30 tunnels or the rock, the lining being arranged as a continuous lining along the tunnel in lengthwise sections, and crosswise, forming a water tight, continuous barrier. The barrier is carried and supported inter alia by the rock bolts. At pointwise points where lining is threaded onto the anchor bolts, leakages occur due to perforations made in

the lining for threading the lining to the rock bolts. Use of plates or discs together with intermediate seals threaded on to the rock bolt, the discs or plates being positioned on each side of the lining at the rear and/or the front of a tunnel lining for sealing purposes and for load bearing purposes, are known. A backing plate with  
5 rubber seal at the rear side and a front washer on the opposite side is one example of such use, where the backing plate with rubber seal establishes a sealing between the bolt and plate and the front washer is establishing a sealing by being pressing the front disc onto the lining.

10 EP 1950375 B1 describes a prior art support for linings with a seal at the outer side of the construction, securing against traversing water intrusion.

NO 172507 relates to a disc for fixing insulation mats in a tunnel or the like, configured to be supported by bolts anchored in the surrounding rock formation. The  
15 disc is provided with a centrally arranged hole or aperture for receipt of the bolt and where the hole or aperture is provided with a sealing element or bushing of an elastic material, extending through the hole or a radially inwards extending flange with a lip shape which, when compressed in axial direction is pressed inwards against the bolt for sealing.

20

NO 337607 discloses a disc system for fixing a membrane or insulation mats to the rock wall for example in a tunnel by bolts anchored in the wall. The system comprises the disc with a concentric aperture in a solution with a washer and a nut for securing the membrane or insulation mats to the rock wall. The disc fixed closest  
25 to the wall and on the inner side of the membrane is different to the disc fixed at the opposite side of the membrane. The disc comprises a pressure seal arranged around the periphery of the disc on the side to be pressed against the membrane. The disc further comprises a seal in the concentric aperture of the disc which may have one or two protruding flanges to be pressed against the thread of the bolt.

30

US 4,712,802 discloses a sealing washer comprising an apertured metal backing member, a sealing member of resilient material abutting one face of the backing

member forming a laminate therewith. The sealing member protrudes out of the concave side of the backing member and the part of the sealing member to be pressed against the bolt for sealing protrudes out of the opposite side of the sealing surface. The sealing side of the backing member is also formed with two concentric  
5 ribs of rounded cross sections, one located at the periphery of the washer and one located around the inner central aperture of the washer. The ribs will be pressed against a workpiece, such as a roofing sheet, by means of a headed fastener through the aperture, and prevent water intrusion lateral under the washer and seal around the bolt.

10

AU 2012 216 578 B2 discloses a sealing device for use in attaching mill linings to mill shells in a grinding mill in order to prevent egress of liquid from the mill interior through the apertures.

15 US 4 230 326 A discloses a sealing assembly for use on equipment employed by the mining and cement industries.

WO 03/078853 A1 discloses a washer assembly used to secure sheeting material to a substrate, such as roof sheeting.

20

NO 20171905 discloses a disc for fixing and sealing a lining to a supporting surface, such as the walls and ceiling of a tunnel. The disc comprises a seal providing locking and sealing surface around a bolt and towards a sealing surface. The seal forms an integrated unit with the disc protruding only on one side of the disc intended to face  
25 towards the lining. The seal comprises an outer peripheral seal arranged along the outer rim of the disc and an inner seal for sealing towards the bolt. The inner seal projects, in an axial direction, outside of the outer peripheral seal and comprises a bottom surface configured to press against a facing surface in use.

30 Before threading the lining onto the anchor bolts, which may be threaded bolts, discs used for sealing purposes are threaded onto the bolts and acts as a sealing and an inner barrier and back support of the lining, at the rear side of the lining. The disc

stops at a predefined distance from the tunnel/rock wall or ceiling by means of a stopping device that may be a nut. A seal for sealing the bolt is either preinstalled onto the disc or retrofitted outside of the disc, facing outwards towards the lining. A seal, covering the disc surface facing the lining, is thereafter installed. Then the lining  
5 is installed, and the seal preinstalled or retrofitted the disc is sealing both against the bolt and the surface of the lining. A further disc is threaded onto the anchor bolt on the front side of the lining, with or without an additional seal. A further nut is threaded onto the anchor bolt and is tightened in order to keep the lining in place and in locked position, but also to press the two discs on both side of the lining towards each other  
10 and to make the discs seal even tighter.

When working up under tunnel ceiling, enhanced handle of objects, reduced weight, and installation procedures are important. In order to keep the weight as low as possible, use of steel as such plates mentioned is not a contribution to such  
15 enhanced working environment and health, safety and environment. Another challenge is to keep the objects in place while installing further objects. Further, preventing objects from falling off/down and potentially cause injury to the operators and/or cause additional work are of essence.

20 Further, the steel discs, if not made of stainless steel, are to be coated or painted with anti-corrosion coating or paint preventing formation of rust. When handled during storing, transporting or mounting, the coating or paint might be damaged, which will shorten the lifetime of the discs due to for example formation of corrosion.

25 The anchor bolts are commonly installed in the tunnel or rock wall and ceiling in a grid pattern at for example a distance of 120 cm x 120 cm. The bolts have several functions. The bolts are keeping the lining at a correct distance from the tunnel/rock wall or ceiling around the entire tunnel profile. Further, the bolt also serves as an attachment for the lining and the bolts serves as a reinforcement support for the  
30 concrete and the concrete itself, installed outside of the lining. A large number of anchor bolts is needed and a corresponding number of discs and thereby many man-hours for installation. The need of anchor bolts can reach a number of several

hundred thousand in one single tunnel dependent upon length, width and height of the tunnel.

5 A disc is normally made of steel with a diameter of approximately 140 mm and a thickness of 3-4 mm, each with a weight around 0.4 kg and provides good resistance from load due to clamping forces, air pressure and pulling suction of passing trains, cars and heavy goods vehicles.

10 The lining used may be thin membrane or linings but may also be foam plates typically at thicknesses of 20-90 mm. PE foam is widely used. When nuts are torqued and the discs are pressed against the foam, the foam will yield. Over time this will cause challenges, since PE does not have any “memories” and will not tend to recover its original shape or thickness when the compressive force is removed. Due to this fact there can be a need for periodically tightening the nuts before  
15 spraying on shotcrete or installing concrete elements, tension between the discs and the PE foam will gradually be reduced and the sealing properties will gradually cease, and thereby not function as intended.

### Summary of the invention

20 The principle used in the present invention is to depend on the sealing and flexible properties of the sealing material used while the material used and the shape or configuration of the system itself is to secure a sufficient rigidity in the sealing. This means that it is the compression of the sealing material that causes the sealing effect while the compressive forces required to provide the sealing effects are  
25 achieved by a wedging effect between a disc and a gasket centrally arranged in a central through hole of the disc. In embodiments, an externally arranged system of stopping means, such as nuts or other suitable accessories on the accessible side of the sheet to be fastened to apply a further compressive force to the gasket. Common features for the various embodiments of the system is: a rigid, slightly  
30 concave/convex disc with a central through hole; a sealing arrangement or gasket associated with the central hole of the disc for sealing against the bolt on which the disc is intended to be threaded and the central hole of the disc; and a sealing

arrangement with an outer peripheral seal arranged around the periphery of the disc and an inner sealing arranged between the central through hole and the outer peripheral sealing of the disc on the side intended to face the sheet, foam or lining to be fixed. The disc is adapted to receive gaskets of different dimensions. E.g.,

5 gaskets of different chamfer angles and/or different outer diameters or the gasket can be produced to adapt to different bolt dimensions and different threads of the bolts. The stopping means can also be produced in several different dimensions to adapt different bolt dimensions and different threads of the bolts.

10 Another general principle applicable to the various embodiments is the contact between the two discs of the system, each disc together with a centrally arranged gasket and the pressure exerted by one disc to the other producing the sealing effect by pressing the end of the sealing surface of the outer peripheral and inner seal of the disc and the centrally arranged gaskets or sealing devices against the other.

15 The compression of the centrally arranged gasket or sealing device is obtained by arranging the free end of the gasket or central sealing device to extend outside the curved arc on the concave side of the disc to come in contact with the corresponding free end surface of the gasket or central sealing device, arranged on the opposite side of the membrane or insulation mat. By forcing the outer disc, i.e. the disc on the

20 free side of the lining, membrane or insulation mat inwards towards the inner disc, a compressive force and effect will be formed in both centrally arranged gasket or sealing devices, securing sealing at least between the inner disc and the corresponding bolt. In case a membrane is used, the contact between the free end of each sealing device will be direct, transferred through the thin membrane. In case of

25 a compressible insulation mat of e.g. foam with a certain thickness the system on both side will be tightened towards the foam such that the seals and gasket will be pressed into the foam sufficiently to provide a water tight transition, slightly deforming the foam, without causing an effect on the insulation in the region for the corresponding hole or penetration.

30

In the following, and throughout the specification, the following terms means:

- The term “lining” or “surfaced to be sealed” used in this specification means a membrane, an insulation sheet, a lining or similar type of installations.  
Bendable to follow the contour of the supporting surface to be protected or covered.  
5
- The term “disc material” means rigid material, suitable with or without ribs or the like to form a rigid disc, such as filled and unfilled engineering plastics and thermoplastics/polyolefin, including but not limited to PP, PE, PVC, and PA, composites or metals.
- 10 – The term “seal material” means an elastic material, suitable to be deformed when subjected to a pressure or compression, such as engineering plastics and thermoplastics/polyolefin, including but not limited to synthetic rubber such as thermoplastic elastomer, TPE, styrene ethylene butylene styrene, SEBS or thermoplastic olefin, TPO with a characteristic of being soft, elastic  
15 and thereby also deformable, and hold sealing properties when being deformed.
- The term “metal” means, include but not be limited to, steel, aluminium, light alloys or the like.
- The term “gasket” means a centrally arranged sealing device to seal towards  
20 the bolt, the central hole of the disc and the lining.

An object of the invention is to provide a system for fixing and supporting an element forming a temporary or permanent part of a tunnel wall or roof, preventing debris, water, ice or rock from falling down into a tunnel room or preventing or serving as a  
25 fire protection, or serving as an insulation preventing formation of ice on the wall or roof.

Another object of the present invention is to improve in a simple manner the seal associated with the system, enhancing the sealing effect of the system both towards  
30 the supporting bolt and also towards the lining or insulation as such, preventing intrusion or leaked water through the lining in the bolt penetration regions or sidewise through the joint between the disc and the membrane/mat.

Yet another object of the invention is to provide elements for such system, such as a system for mounting a water, frost and fire protecting material, such as a lining, to bolts anchored in rock wall or ceiling, in for example tunnels, and provide a  
5 waterproof transition between bolts, disc and perforated holes in lining in which the lining is threaded on to the bolts.

Moreover, it is an object of the present invention is to provide a system that provides a robust and efficient sealing of the lining of a wall or ceiling of a tunnel or rock.  
10

Another object of the present invention is to extend the lifetime of the system with a material that cannot rust and will not be damaged due to handling and mounting.

Another object of the present invention is to provide a system with better sealing  
15 against anchor bolts, both threaded and unthreaded anchor bolts, and against a lining.

Similarly, it is an object of the present invention is to provide a system with better and long-lasting sealing to anchor bolts and insulation sheet when installing PE  
20 foam.

Another object of the present invention is to provide a system for sealing purposes robust to heavy loads.

25 Another object of the present invention is to provide a disc with reduced weight still maintaining good bending stiffness.

It is also an object of the present invention to provide a disc with an integrated sealing, formed by injection moulding in the one and same operation.  
30

Another object of the present invention is to provide a system allowing a more efficient and cost-effective production, thereby reducing the production costs for each specimen.

- 5 Yet another object of the present invention is to provide a system allowing a more cost-effective installation, also enhancing the health, environment and safety for the operators installing the lining.

10 Yet another object of the invention is to provide a system and a method where an insulation mat is not unnecessarily compressed in order to obtain a sealed support.

Another object of the present invention is to reduce labour time and reduce risk of operator while installing lining in walls and ceilings, in for example tunnels, through reduced weight on discs and through integrated component replacing several  
15 components and thereby ease handling of components.

The objects of the present invention are achieved by means of a system as further defined by the independent claims, while embodiments, alternatives, modifications and variants are defined by the dependent claims.

20

The present invention relates to a system for sealed attachment and support of a lining, membrane or PE foam to a supporting surface being tunnel or rock walls or ceilings, the lining, membrane or PE foam being intended to be fixed to the supporting surface by a plurality of bolts fixed in the supporting surface said system  
25 comprises

- a disc for threading onto the bolt said disc comprises
  - a central through hole, and
  - a seal providing a sealing surface towards the lining said seal forms an integrated unit with the disc and only protrudes out at one side of the  
30 disc said seal comprises
    - an outer peripheral seal arranged along the outer rim or circumference of the disc, and

- an inner seal arranged concentrically to the outer peripheral seal between the central through hole and the outer peripheral seal wherein the outer peripheral seal and inner seal projects in axial direction out of the disc wherein the bottoms of the outer peripheral seal and inner seal are configured to press against a facing surface in use,
- 5           – a gasket, wherein the gasket has
  - a central through hole providing locking and a sealing surface around the bolt, and
  - 10           ○ a chamfered outer surface providing a locking and sealing surface towards the central though hole of the disc.

In embodiments, the gasket is configured to be squeezed towards the surface to be sealed and towards the bolt making a watertight transition to the bolt.

15

In embodiments, the central through hole of said gasket is a threaded through hole for providing improved watertight transition with the bolt. Preferably having threads corresponding to a threaded bolt.

20 In embodiments, said central through hole of said disc is having a chamfered inner surface wherein said chamfered inner surface of the disc provides a squeezing force onto said chamfered outer surface of the gasket squeezing the gasket towards the bolt.

25 In embodiments, the outer peripheral seal is arranged on the surface intended to face towards the lining and is formed of one bulb or protrusion.

In embodiments, wherein the outer peripheral seal is arranged on the surface intended to face towards the lining and is formed of a plurality of ridges spread in  
30 radial direction of said central through hole.

In embodiments, wherein the inner seal is arranged on the surface intended to face towards the lining and is formed of one bulb or protrusion.

5 In embodiments, wherein the outer peripheral seal and/or the inner seal are rounded and semi-circular or semi-oval formed protrusions.

In embodiments, the outer peripheral seal is integral with the inner seal by means of radial spreading as ribs from said outer peripheral seal towards the inner seal or the outer peripheral seal is integral with the inner seal by means of radial spreading as ribs from said outer peripheral seal towards the inner seal with crossing ribs in a crossing pattern like a waffle pattern, or  
10 the outer peripheral seal is integral with the inner seal by means of radial spreading as ribs from said outer peripheral seal towards the inner seal with further ribs, preferably perpendicular to and at least one per rib in radial direction forming a  
15 crossing pattern.

In embodiments, the disc on the side opposite the sealing surface, comprises ribs established throughout the circular surface of the disc in order to increase bending stiffness of the disc.

20

In embodiments, the gasket is being squeezed into the central through hole of said disc and is being deformed when pressed against bolt and the opposite seal or lining and sufficiently sealing bolt and into the bolt threads and the perforated hole in the lining in which the anchoring bolt is protruding through when lining is installed.

25

In embodiments, the gasket comprises a chamfer sloping inwards towards the central through hole and an approximately horizontal surface on the bottom of the gasket facing the lining.

30 In embodiments, the disc is used on both sides of the lining assembled laterally reversed and secured by the gaskets tightened to press the discs and thereby the

seals and the gaskets themselves on both sides of the lining towards each other in a watertight manner.

In embodiments, the disc is used on both sides of the lining assembled laterally  
5 reversed and secured by nuts tightened to press the discs and thereby the seals and the gaskets on both sides of the lining toward each other in a watertight manner.

In embodiments, the main body of the disc is made in a plastic or metallic material, while the disc in total, i.e. the disc with the integrated seal is made of two different  
10 materials/two component material, wherein the main body is made of polypropylene, PP, high density polyethylene, HDPE, polyvinyl chloride, PVC, polyamide/nylon, PA or aluminium and the seal is made of synthetic rubber such as thermoplastic elastomer, TPE, styrene ethylene butylene styrene, SEBS or thermoplastic olefin, TPO.

15 In embodiments, the gasket is made of synthetic rubber such as thermoplastic elastomer, TPE, styrene ethylene butylene styrene, SEBS or thermoplastic olefin, TPO, or the gasket is made of hard plastics such as polypropylene, PP, high density polyethylene, HDPE, polyvinyl chloride, PVC, or polyamide/nylon, PA, or the gasket  
20 is made of combinations of synthetic rubber and hard plastic. E.g., the gasket can be moulded in hard plastic to form structure or rigidity and alternatively together with sealing material of synthetic rubber for sealing characteristics.

In embodiments, the gasket has a hexagonal portion at the chamfered outer surface,  
25 on the side of the gasket having the largest diameter, for tightening the system towards the lining by means of e.g., a hexagonal socket spanner, a shifting spanner or the like.

In embodiments, the gasket has a friction element, e.g. of synthetic rubber, on the  
30 chamfered outer surface of the gasket or a fastening element, keeping the disc in place during installation of the system on a lining.

The disc may be injection moulded in a two-cavity mould for a multi-component injection moulding process.

The disc with the integrated seal may be made in a one-step or a two-step process, where the disk initially may be pressed or moulded in a first step and thereafter placed in an injection moulding machine for injection moulding of the seal onto the metal.

A method for installation of the system on a lining comprises the steps:

- 10 – threading a gasket onto an anchor bolt until it faces a preinstalled stopping means on the anchor bolt preferably a nut, at a predetermined distance from the tunnel wall,
- threading a disc, with its seal turning outwards, onto the anchor bolt providing a wedged arrangement with the gasket,
- 15 – threading the lining at perforations in the lining onto the anchor bolt facing the seal side of the disk,
- threading another disk, with its seals turning inwards towards the lining, the opposite way of the disk firstly installed on to the anchor bolt, facing with its seal side against the lining,
- 20 – threading another gasket onto the anchor bolt, turning the opposite way of the first threaded gasket,
- threading a stopping means, preferably a nut, onto the anchor bolt,
- tightening the discs on both side of the lining towards each other by means of the stopping means, the two opposite gaskets pressing face to face or
- 25 pressing at each side of the lining in order to deform the gasket and thereby squeezing the gasket towards the bolt making a watertight transition to the bolt.

Alternatively, the system is installed on a lining according to a method comprising the steps:

- 30 – threading a gasket onto an anchor bolt until it is at a predetermined distance from the tunnel wall,

- threading a disc, with its seal turning outwards, onto the anchor bolt providing a wedged arrangement with the gasket,
- threading the lining at perforations in the lining onto the anchor bolt facing the seal side of the disk,
- 5 – threading another disk, with its seals turning inwards towards the lining, the opposite way of the disk firstly installed on to the anchor bolt, facing with its seal side against the lining,
- threading another gasket onto the anchor bolt, turning the opposite way of the first threaded gasket,
- 10 – tightening the discs on both side of the lining towards each other by means of the gasket with the central threaded through hole, the two opposite gaskets pressing face to face or pressing at each side of the lining in order to deform the gasket and thereby squeezing the gasket towards the bolt making a watertight transition to the bolt.

15

One method for manufacturing of the disc in an injection moulding process by use of at least one injection moulding machine where the main body of the disc is overmoulded by the TPE, SEBS or TPO material. The injection moulding process may be characterized in either a one-step or two-step process.

20

The method for manufacturing of the disc through a one step injection moulding process which may comprise the use of an injection moulding machine with one or two injection units where the TPE, SEBS or TPO may be overmoulded directly onto PP, HDPE, PVC or PA later or immediately after PP, HDPE, PVC or PA has been moulded, with the same injection moulding machine where firstly the PP, HDPE, PVS or PA may have been injected into an initial mould and then the TPE, SEBS or TPO may have been injected into a another mould placed on top of the initial mould by rotating a core mould.

25

The method for manufacturing of the disc in a two-step process may comprise the steps:

30

- a step where the main body of the disk in a first machine may either be moulded by a first injection moulding machine or pressed by metalworking,
- a further step of transferring the main body of the disk into the mould of the second machine for injection moulding, where the TPE, SEBS or TPO may be overmoulded directly onto the main body of the disk.

The seal of the disc and the gasket are sufficiently sealing the perforated hole in the material for water and frost protection in which the anchoring bolt is protruding through after installation of water and frost protecting material.

10

The system is for securing a water and frost tight barrier at perforation in the lining while fixing a lining to a wall or ceiling of a tunnel where the lining is threaded onto anchor bolts and where the system act as the water and frost tight sealing of the lining and bolt. The system is installed at a predetermined distance from the tunnel walls or ceilings, and the system comprising a disc and a gasket is threaded onto a plurality of anchor bolts, preferably threaded bolts, which is bolted to the tunnel walls or ceilings, the system stops at a predefined distance of the tunnel walls or ceilings, alternatively the system stops at a predefined distance of the tunnel walls or ceilings at a preinstalled stopping means, which can be a nut. The gasket is first threaded onto the bolt at the predefined distance of the tunnel walls or ceilings or up to and toward the preinstalled stopping means, which may be a nut. Thereafter the disc is threaded onto the bolt. The gasket is made of a flexible or rubber material and is having a chamfered outer surface, wherein the side of the gasket having the largest diameter is facing the tunnel walls or ceilings, or the tunnel walls or ceilings and the stopping means. The chamfered surface is having a wedging effect and when the disc with the centrally arranged hole is being threaded onto the bolt, the disc is being wedged onto the gasket. The centrally arranged hole of the disc encloses the gasket, exerting an inward acting force onto the gasket, providing the wedging effect and sealing the central through hole of the disc. The gasket is thus being pressed towards the anchoring bolt for a sealing effect towards the bolt, and is yielding towards the centrally arranged hole of the disc having a sealing effect towards the disc. The lining is thereafter threaded at perforations in lining onto the anchoring

bolts, which is preferably spreading at a distance from each other throughout the tunnel, new discs and gaskets are threaded onto the bolts, the opposite way of the discs and gaskets firstly installed, an alternatively a new stopping means, which can be a nut, is threaded onto the bolts and tightens the discs and gaskets on both side  
5 of the lining towards each other. The discs and gaskets are having a wedging effect in the centrally arranged hole of the disc, providing a sealing effect both between the gasket and bolt and between the gasket and the centrally arranged hole of the disc. The more the gasket or stopping means is tightened the better sealing effect, the gasket arranged in the centre of the disc is being squeezed inwards and embraces  
10 the anchoring bolt tighter and tighter and the outer circumferential seal and inner seal of the disc gains tighter and tighter contact with the lining with increased pressure on disc from the gasket or stopping means which can be a nut being torqued inwards.

15 Having a system with two separate components, a disc and a gasket, a variety of gaskets of different dimensions can be used in order to accommodate different bolt dimensions and different bolt thread geometries. The gasket is accommodating bolt diameters of 10-50 mm, preferably 12-35 mm and more preferably 16-32 mm.

20 As the gasket is having a chamfered outer surface, the wedging effect is dependent upon how long, in the axial direction with increasing diameter of the gasket, the disc is pressed onto the gasket. Thus, the wedging effect is not dependent upon the height of the disc in axial direction of the disc, and the disc can be made with only a little height. Reducing space when the disk is installed, and the space needed when  
25 transporting.

The means for sealing off the lining also serves as a securing element securing the water and frost proofing lining to the tunnel or rock wall or ceiling at a predefined distance to the tunnel or rock wall or ceiling.

30

The disc is provided with ribs for stiffening purposes in order for the disc to be able to withstand heavy loads.

The discs according to the present invention provides a lighter disc of a plastic material with integrated sealing, where the integrated sealing is formed in the same moulding operation and by the same tool as the moulding of the disc.

5

Both costs associated with the manufacture and installation process are reduced, due to the integrated sealing as part of the moulding of the disc and due to elimination of components related to the integrated seal in the disc, which leads to easier and more efficient handling at tunnel site.

10

Due to the integrated sealing, the discs also provide a more reliable sealing effect with reduced exposure for a leakage.

The disc with the integrated seal is made of two different materials one stiff material to keep the strength and the shape and one material to function as a seal. The stiff material can be thermoformed or compressing moulded of for example polypropylene, PP, high density poly ethylene, HDPE, polyvinyl chloride, PVC or polyamide/nylon PA and the seal material can be synthetic rubber such as thermoplastic elastomer, TPE, styrene ethylene butylene styrene, SEBS, or thermoplastic olefin, TPO. The stiff material can also be a filled material with for example glass to gain extra stiffness. It can also be filled with flame retardant to prevent from burning. The sealing and the gasket, of for example TPE, SEBS or TPO, has a hardness in the shore A hardness scale within the area of 20-90 A, preferably with a shore 50 A, and more preferably with a shore 30 A may be preferably. Different shore on inner and outer sealing might be preferred, and then preferably with a lower shore on the inner sealing.

30

The health, safety and environmental aspect is also improved due to the reduced weight of each disc compared with a steel disc.

The system can also be applied outside rocky walls where bolts is rigidly fixed in order to secure bits of rocks from falling out either because of unfixed rocks or where

water intrusions makes conditions where bits of rocks loosen. The system is then used to prevent water additional intrusion along the anchoring bolt.

The disc manufactured in either a one-step injection moulding process or in a two-  
5 step injection moulding process, where the two step injection moulding process is using two injection moulding machines where the disc material is moulded in a first machine and where the component of disc material are transferred into the mould of a second machine and then overmoulded by the seal material. And the one step injection moulding process is using one injection moulding machine with two injection  
10 units where the seal material is overmoulded directly onto the disc material (filled and unfilled engineering plastics and thermoplastics/polyolefin and composites) immediately after the disc material has been moulded, in the same mould, and with the same injection moulding machine where firstly the disc material is injected into an initial mould and secondly the seal material is injected into a secondary mould  
15 placed on top of the initial mould by rotating a core mould. The one step injection moulding process, also known as 2-Shot-, multi-component-, in-mould-, twin shot- or assembly injection moulding process creates a strong, tight seal without the need for additional components and is a preferred manufacturing method for products where water-tightness is required.

20

### **Description of the figures**

Embodiments of the present invention will now be described, by way of example only, with reference to the following diagrams wherein:

25 Figure 1 shows schematically a cross section of an assembly of prior art.

Figure 2 shows schematically a cross section through a tunnel, prior to further reinforcement and shotcreting or installing concrete elements, indicating a lining, a plurality of anchoring bolts and the system of the present invention of discs and  
30 gaskets for sealing.

Figure 3a shows schematically a front view of an embodiment of the system 100 wherein a gasket and a disc is threaded onto a bolt.

5 Figure 3b shows a cross section of one embodiment of the system of the present invention.

Figure 4a shows a front view of an embodiment of the gasket of the system. Figure 4b shows a cross sectional view of figure 4a

10 Figure 5a shows schematically a front view of one embodiment of the disc of the system. Figure 5b shows a cross sectional view of figure 5a

Figure 6 shows schematically a cross section of detail A from figure 2, showing an embodiment of the present invention assembled with the lining in a tunnel wall (not  
15 shown).

Figure 7 shows schematically a cross section of detail A from figure 2, showing an embodiment the present invention assembled with the lining in a tunnel wall, where the lining is a thick PE-foam.  
20

#### **Description of preferred embodiments of the invention**

The following description of the exemplary embodiments refers to the accompanying drawings. The same reference numbers in different drawings identify the same or  
25 similar elements. The following detailed description does not limit the invention. Instead, the scope of the invention is defined by the appended claims.

Reference throughout the specification to “one embodiment” or “an embodiment” means that a particular feature, structure or characteristic described in connection  
30 with an embodiment is included in at least one embodiment of the subject matter disclosed. Thus, the appearance of the phrases “in one embodiment” or “in an embodiment” in various places throughout the specification is not necessarily

referring to the same embodiment. Further, the particular features, structures, or characteristics may be combined in any suitable manner in one or more embodiments.

5 Figure 1 shows schematically a cross section of an assembly of prior art. A bolt to be anchored to the tunnel wall, a nut at a predefined distance from the tunnel wall which act as a stopping means for the lining, a washer between the nut and a seal preinstalled or retrofitted in the centre hole of the sealing disc, a sealing sheet at least covering the disc area between the disc with the seal and the lining, a new disc,  
10 with or without seal outside the lining a washer between the outer disc and the nut which is torqued in order to the discs against the lining and make a water proof transition between the anchoring bolt and lining. The washers are required in order to prevent damages to the seals, and thereby the sealing properties, and discs when torqued against the nut.

15

Figure 2 shows schematically a cross section through a tunnel, prior to further reinforcement and shotcreting or installing concrete elements, indicating a lining 130, a plurality of anchoring bolts 140 and the system 100 of the present invention of discs and gaskets for sealing. As indicated, a plurality of anchoring bolts 140 is  
20 drilled into the surrounding rock 170 and penetrating the lining 130. In order to secure water tightness, the penetration may be sealed, and conventional sealing material with load distributing discs 110 may be used. The lining 130 may be of flexible and bendable sheets extending for example as a unit following the entire profile shape of the tunnel. In the longitudinal direction of the tunnel, sections of  
25 transversely extending lining 130 sheets may be arranged in an overlapping pattern. The lining 130 may also be of thick PE foam with thicknesses from 20-90 mm.

Figure 3a shows schematically a front view of an embodiment of the system 100 wherein a gasket 120 and a disc 110 is threaded onto a bolt 140.

30

Figure 3b shows a cross section of one embodiment of the system 100 of the present invention. The disc 110 and the seal 112, 113 which may form an integrated

part are separately indicated. The seal 112, 113 is to be continuously from centre hole 111 to the outer rim of the disc 110. The outer peripheral seal 112 is concentrically arranged around the circumference of the disc 110 and may be semi-circular or semi-oval. The inner seal 113 is concentrically arranged in regard to the outer peripheral seal 112 and arranged between the outer peripheral seal 112 and a central through hole 111 of the disc 110 and may be semi-circular or semi-oval.

Figure 4a shows a front view of an embodiment of the gasket 120 of the system 100. The gasket 120 having a chamfered outer surface 122 for wedging with the central through hole 111 of the disc 110.

Figure 4b shows a cross sectional view of figure 4a. The gasket 120 having a central through hole 121 for treading onto a bolt 140. The gasket 120 has a bottom 123 configured to press against a facing surface or a facing gasket 120. The central through hole 121 of the gasket 120 may be threaded. The threads may correspond to threads of the bolt 140.

Figure 5a shows schematically a front view of one embodiment of the disc 110 of the system 100, the disc 110 preferably having a circular shape (not shown).

Figure 5b shows a cross sectional view of figure 5a. The disc 110 having a central through hole 110, the central through hole 110 is having an inner surface 144. The inner surface 114 is preferably chamfered contributing to the wedging effect with the gasket 120. The disc 110 further comprises an outer peripheral seal 112 concentrically arranged around the rim of the disc 110 and an inner seal 113 arranged concentrically of the outer peripheral seal 112. The inner seal 113 is arranged between the outer peripheral seal 112 and the central through hole 111 of the disc 110.

Figure 6a shows schematically a cross section of detail A from figure 2, showing an embodiment of the present invention assembled with the lining 130 in a tunnel wall 170 (not shown). A bolt 140 is anchored in the tunnel wall 170, a stopping means

150, which might be a nut, is installed at a predefined distance from the tunnel wall 170 keeping the lining 130 at a desired distance from the tunnel wall 170. The system 100 is installed by first threading the gasket 120 onto the bolt 140 up to and facing by its largest diameter the stopping means 150. Thereafter the central  
5 through hole 111 of the disc 110 is threaded onto the bolt 140 and threaded and pressed onto the gasket 120, wherein the inner surface 114 of the central through hole 111 of the disc 110 is facing and wedging with the chamfered outer surface 122 of the gasket 120. The inner surface 114 is preferably chamfered, further contributing to the wedging effect between the disc 110 and the gasket 120. The disc 110 and  
10 the gasket 120 is thus forming a wedged arrangement, where the gasket 120 is pressing out towards the central through hole 111 of the disc 110 and an inner surface 121 of the gasket 120 is pressing inwards towards the bolt 140, forming a water tight transition between the disc 110 and the gasket 120 and between the gasket 120 and the bolt 140. The disc 110 with the integrated seal 112, 113, is  
15 having the seal 112, 113 facing outwards, then the lining 130 is threaded outside the disc 110 and gasket 120. The seal 112, 113 is facing the lining 130 and the gasket 120 is facing the lining 130 and the perforated hole in the lining 130. A new disc 110 is installed by threading it onto the bolt 140 outside the lining 130, the opposite way of the disc 110 firstly installed, a new gasket 120 is thereafter threaded onto the bolt  
20 140 and penetrating the disc 110 in a wedged arrangement with the disc 110. A new stopping means 150, which may be a nut, is thereafter threaded onto the bolt 140 and may be tightened in order to press the discs 110 and the gasket 120 on both side of the lining 130 towards each other, and thereby pressing the seal 112, 113 and gasket 110 to squeeze the sealing. And the outer peripheral seal 112 arranged  
25 around the outer rim of the disc 110 and the inner seal 113 arranged concentrically to the outer peripheral seal 112, between the central through hole 111 and the outer peripheral seal is squeezed towards the lining 130 securing a waterproof transition in the interfaces exposed to possible and unwanted water.

30 Figure 6b shows schematically a cross section of detail A from figure 2, showing a similar embodiment as of figure 6a of the present invention assembled with the lining 130 in a tunnel wall 170 (not shown). A bolt 140 is anchored in the tunnel wall 170.

The system 100 is installed by first threading the gasket 120 onto the bolt 140 at a predefined distance from the tunnel wall 170 keeping the lining 130 at a desired distance from the tunnel wall 170, facing by its largest diameter the tunnel wall 170. Thereafter the central through hole 111 of the disc 110 is threaded onto the bolt 140 and threaded and pressed onto the gasket 120, wherein the inner surface 114 of the central through hole 111 of the disc 110 is facing and wedging with the chamfered outer surface 122 of the gasket 120. The inner surface 114 is preferably chamfered, further contributing to the wedging effect between the disc 110 and the gasket 120. The disc 110 and the gasket 120 is thus forming a wedged arrangement, where the gasket 120 is pressing out towards the central through hole 111 of the disc 110 and an inner surface 121 of the gasket 120 is pressing inwards towards the bolt 140, forming a watertight transition between the disc 110 and the gasket 120 and between the gasket 120 and the bolt 140. The disc 110 with the integrated seal 112, 113, is having the seal 112, 113 facing outwards, then the lining 130 is threaded outside the disc 110 and gasket 120. The seal 112, 113 is facing the lining 130 and the gasket 120 is facing the lining 130 and the perforated hole in the lining 130. A new disc 110 is installed by threading it onto the bolt 140 outside the lining 130, the opposite way of the disc 110 firstly installed, a new gasket 120 is thereafter threaded onto the bolt 140 and penetrating the disc 110 in a wedged arrangement with the disc 110. The new gasket 120 may be tightened in order to press the discs 110 and the gaskets 120 on both side of the lining 130 towards each other, and thereby pressing the seal 112, 113 and gasket 110 to squeeze the sealing. And the outer peripheral seal 112 arranged around the outer rim of the disc 110 and the inner seal 113 arranged concentrically to the outer peripheral seal 112, between the central through hole 111 and the outer peripheral seal is squeezed towards the lining 130 securing a waterproof transition in the interfaces exposed to possible and unwanted water.

Figure 7a shows schematically a cross section of detail A from figure 2, showing the present invention assembled with the lining 130 in a tunnel wall 170, where the lining 130 is a thick PE-foam. The principle is the same as indicated in figure 6a. The disc 110 with the integrated outer peripheral seal 112 and inner seal 113, is having the

seals 112, 113 facing outwards, then the foam 130 is threaded outside the disc 110 and gasket 120. The seals 112, 113 is facing the foam 130 and the gasket 120 is facing the foam 130 and the perforated hole in the foam 130. A new disc 110 is installed by threading it onto the bolt 140 outside the foam 130, the opposite way of the disc 110 firstly installed, a new gasket 120 is thereafter threaded onto the bolt 5 140 and penetrating the disc 110 in a wedged arrangement with the disc 110 forming a watertight transition. A new stopping means 150, which may be a nut, is thereafter threaded onto the bolt 140 and may be tightened in order to press the disc 110 and the gasket 120 towards the foam 130, in order to have the gasket 120 and the seal 10 112, 113 of the disc 110 sink into the foam in order to form a water tight transition, the foam slightly deformed at the contact surface between the foam and the gasket 120 and between the foam and the seals 112, 113 of the disc 110 at both sides of the foam.

15 Figure 7b shows schematically a cross section of detail A from figure 2, showing the present invention assembled with the lining 130 in a tunnel wall 170, where the lining 130 is a thick PE-foam. The principle is the same as indicated in figure 7b. The disc 110 with the integrated outer peripheral seal 112 and inner seal 113, is having the seals 112, 113 facing outwards, then the foam 130 is threaded outside the disc 110 and gasket 120. The seals 112, 113 is facing the foam 130 and the gasket 120 is facing the foam 130 and the perforated hole in the foam 130. A new disc 110 is installed by threading it onto the bolt 140 outside the foam 130, the opposite way of the disc 110 firstly installed, a new gasket 120 is thereafter threaded onto the bolt 20 140 and penetrating the disc 110 in a wedged arrangement with the disc 110 forming a watertight transition. The new gasket 120 may be tightened in order to press the disc 110 and the gasket 120 towards the foam 130, in order to have the gasket 120 and the seal 112, 113 of the disc 110 sink into the foam in order to form a water tight transition, the foam slightly deformed at the contact surface between the foam and the gasket 120 and between the foam and the seals 112, 113 of the disc 110 at both 25 30 sides of the foam.

Table 1

Component	Description
100	System
110	Disc
111	Central through hole
112	Outer peripheral seal
113	Inner seal
114	Inner surface
120	Gasket
121	Central through hole of gasket
122	Chamfered outer surface
123	Bottom
130	Lining
140	Bolt
150	Stopping means
170	Supporting surface / Tunnel wall

CLAIMS

1. A system (100) for sealed attachment and support of a lining, membrane or PE foam (130) to a supporting surface (170), being tunnel or rock walls or ceilings, the lining, membrane or PE foam (130) being intended to be fixed to the supporting surface (140) by a plurality of bolts (140) fixed in the supporting surface (170), said system (100) comprises
- a disc (110) for threading onto the bolt (140), the disc (100) comprises
    - a central through hole (111), and
    - a seal (112, 113) providing a sealing surface towards the lining (130), said seal (112, 113) forms an integrated unit with the disc (110) and only protrudes out at one side of the disc (110), said seal (112, 113) comprises
      - an outer peripheral seal (112) arranged along the outer rim or circumference of the disc (110), and
      - an inner seal (113) arranged concentrically to the outer peripheral seal (112), between the central through hole (111) and the outer peripheral seal (112),wherein the outer peripheral seal and inner seal (112, 113) projects in axial direction out of the disc (110) wherein the bottoms of the outer peripheral seal and inner seal (112, 113) are configured to press against a facing surface in use,
  - a gasket (120), wherein the gasket (120) has
    - a central through hole (121) providing a locking and sealing surface around the bolt (140), and
    - a chamfered outer surface (122) providing a locking and sealing surface towards the central through hole (111) of the disc (110).
2. The system (100) according to claim 1, wherein the gasket (120) is configured to be squeezed towards the surface to be sealed and towards the bolt (140), making a watertight transition to the bolt (140).

3. The system (100) according to claim 1 or 2, wherein said central through hole (121) of said gasket (120) is a threaded through hole.
4. The system (100) according to any preceding claim, wherein said central  
5 through hole (111) of said disc (110) is having a chamfered inner surface (114)  
wherein said chamfered inner surface (114) provides a squeezing force onto said  
chamfered outer surface (122), squeezing the gasket (120) towards the bolt (140).
5. The system (100) according to any preceding claim, wherein the outer  
10 peripheral seal (112) is arranged on the surface intended to face towards the lining  
(130) and is formed of one bulb or protrusion.
6. The system according to one of the claims 1-4, wherein the outer peripheral  
seal (112) is arranged on the surface intended to face towards the lining (130) and is  
15 formed of a plurality of ridges spread in radial direction of said central through hole  
(111).
7. The system (100) according to any preceding claim, wherein the inner seal  
(112) is arranged on the surface intended to face towards the lining (130) and is  
20 formed of one bulb or protrusion.
8. The system (100) according to any preceding claim, wherein the outer  
peripheral seal (112) and/or the inner seal (113) are rounded and semi-circular or  
semi-oval formed protrusions.  
25
9. The system (100) according to any preceding claim, wherein the outer  
peripheral seal (112) is integral with the inner seal (113) by means of radial  
spreading as ribs from said outer peripheral seal (112) towards the inner seal (113),  
or  
30 wherein the outer peripheral seal (112) is integral with the inner seal (113) by means  
of radial spreading as ribs from said outer peripheral seal (112) towards the inner  
seal (113), with crossing ribs in a crossing pattern like a waffle pattern, or

wherein the outer peripheral seal (112) is integral with the inner seal (113) by means of radial spreading as ribs from said outer peripheral seal (112) towards the inner seal (113) with further ribs, preferably perpendicular to and at least one per rib in radial direction forming a crossing pattern.

5

10. The system (100) according to any preceding claims, wherein the disc (110), on the side opposite the sealing surface, comprises ribs established throughout the circular surface of the disc (110) to increase bending stiffness of the disc (110).

10 11. The system (100) according to any preceding claim, wherein the gasket (120) is being squeezed into the central through hole (111) of said disc (110) and is being deformed when pressed against bolt (140) and the opposite seal or lining (130) and sufficiently sealing bolt (140) and into the bolt threads and the perforated hole in the lining in which the anchoring bolt (140) is protruding through when lining (130) is  
15 installed.

12. The system (100) according to any preceding claim, wherein the gasket (120) comprises a chamfer sloping inwards towards the central through hole (121), and an approximately horizontal surface on the bottom (123) of the gasket (120) facing the  
20 lining (130).

13. The system (100) according to any preceding claim, wherein the disc (110) is used on both sides of the lining (130), assembled laterally reversed and secured by the gaskets tightened to press the discs (110) and thereby the seals (112, 113) and  
25 the gaskets (120) themselves on both sides of the lining (130) towards each other in a watertight manner.

14. The system (100) according to one of the claims 1-12, wherein the disc (110) is used on both side of the lining (130), assembled laterally reversed and secured by  
30 a stopping means (150) tightened to press the discs (110) and thereby the seals (112, 113) and the gasket (120) on both side of lining (130) toward each other in a watertight manner.

15. The system (100) according to any preceding claim, wherein the main body of the disc (110) is made in a plastic or metallic material, while the disc (110) in total, i.e. the disc with the integrated seal (120) is made of two different materials/two component material, wherein the main body is made of polypropylene, PP, high density polyethylene, HDPE, polyvinyl chloride, PVC, polyamide/nylon, PA or aluminium and the seal (120) is made of synthetic rubber such as thermoplastic elastomer, TPE, styrene ethylene butylene styrene, SEBS or thermoplastic olefin, TPO.
16. The system (100) according to any preceding claim, wherein the gasket (120) is made of synthetic rubber such as thermoplastic elastomer, TPE, styrene ethylene butylene styrene, SEBS or thermoplastic olefin, TPO.
17. The system (100) according to one of the claims 1-15, wherein the gasket (120) is made of hard plastics such as polypropylene, PP, high density polyethylene, HDPE, polyvinyl chloride, PVC, or polyamide/nylon.
18. The system (100) according to any preceding claim, wherein the gasket (120) is made of combinations of synthetic rubber and hard plastic.
19. The system (100) according to claim 17 or 18, wherein the gasket (120) has a hexagonal portion of hard plastic at the chamfered outer surface, on the side of the gasket having the largest diameter.
20. The system (100) according to any preceding claim, wherein the gasket (120) has a friction element, on the chamfered outer surface of the gasket or a fastening element, keeping the disc in place during installation of the system on a lining.
21. The system (100) according to claim 20, wherein the friction element is made of synthetic rubber.

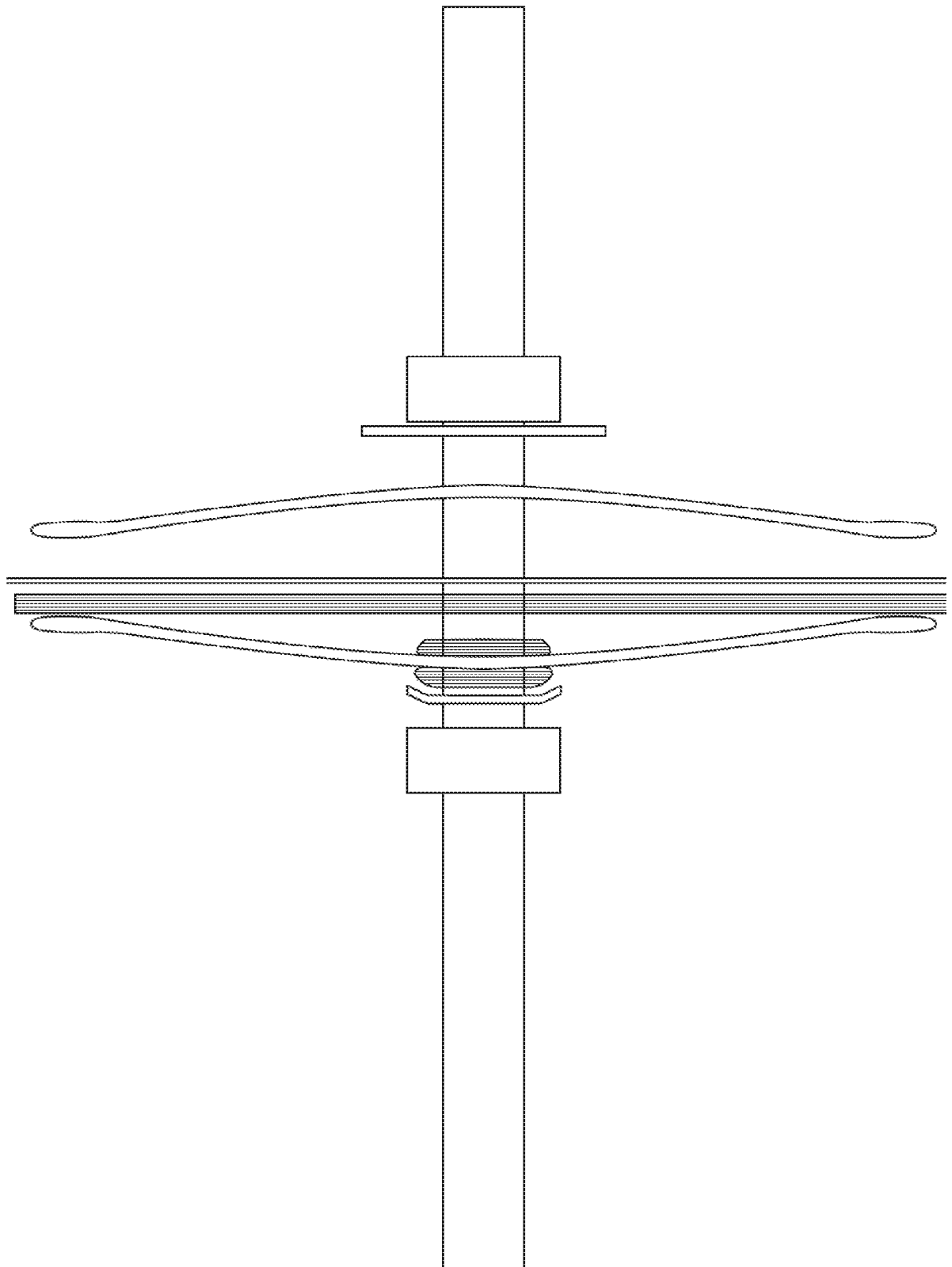

Fig. 1 (Prior art)

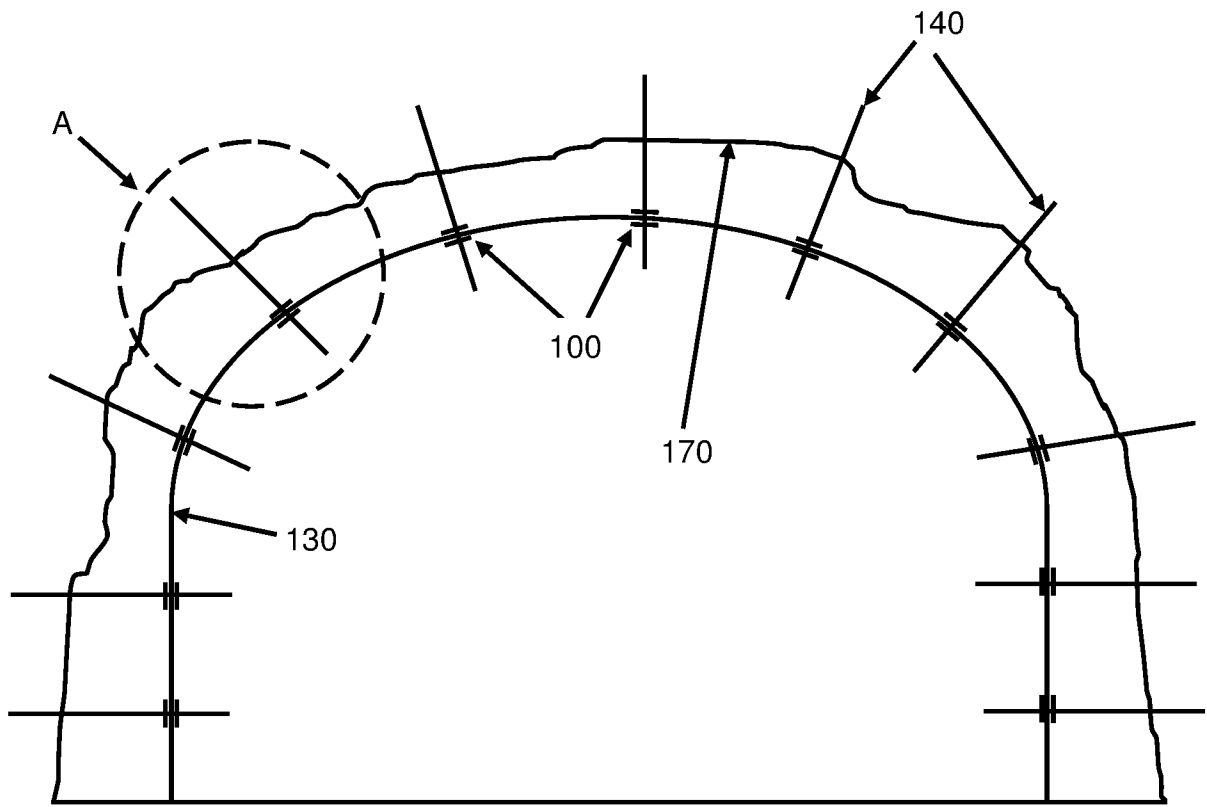

Fig. 2

3/8

5

10

15

20

25

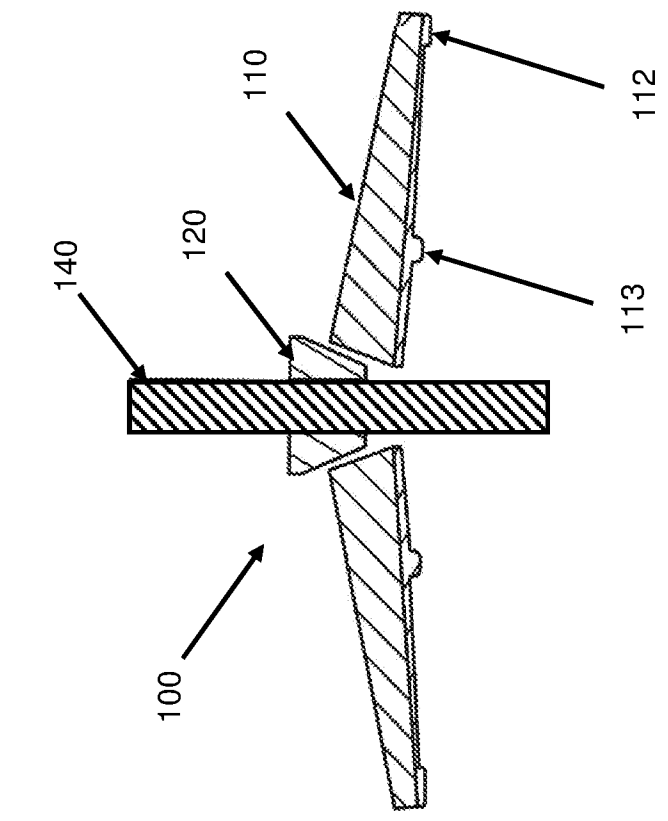

Fig. 3b

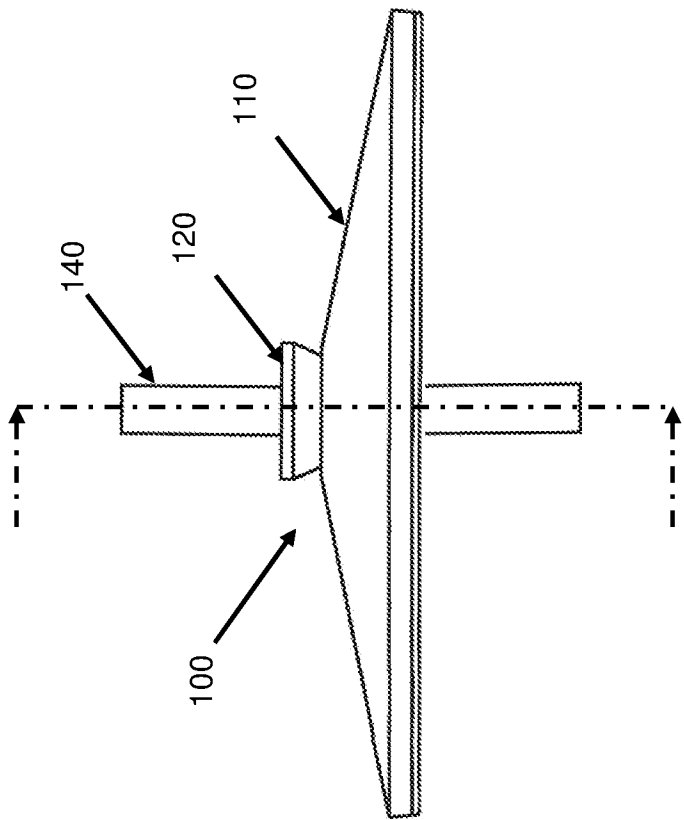
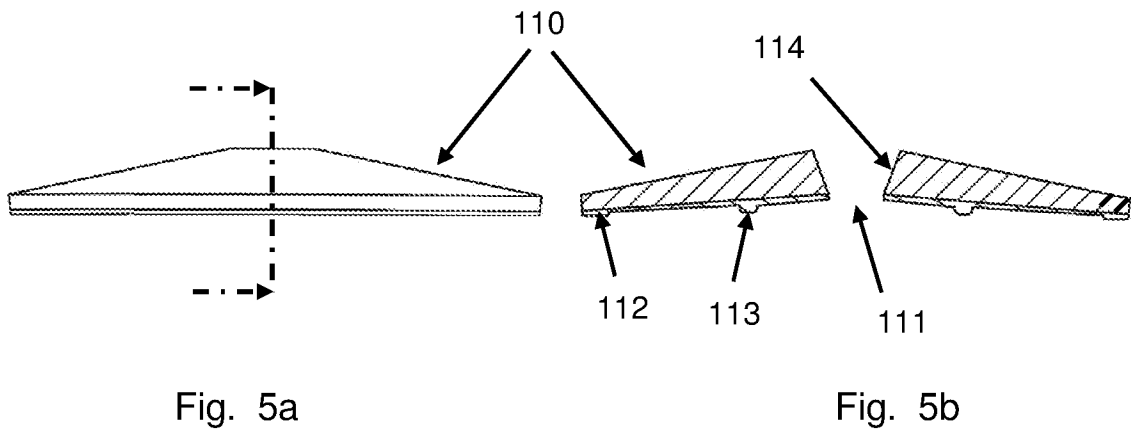
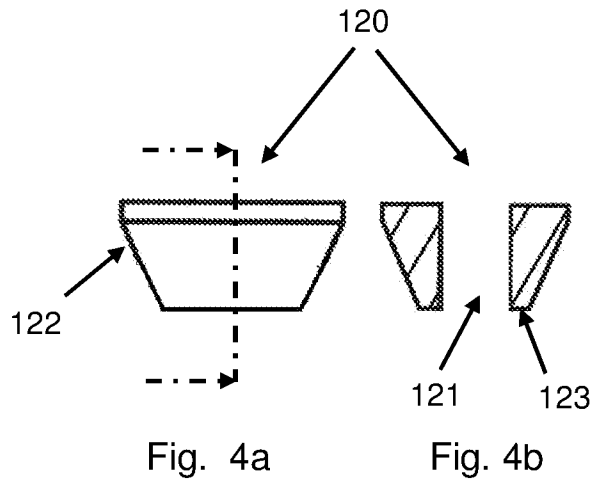

Fig. 3a



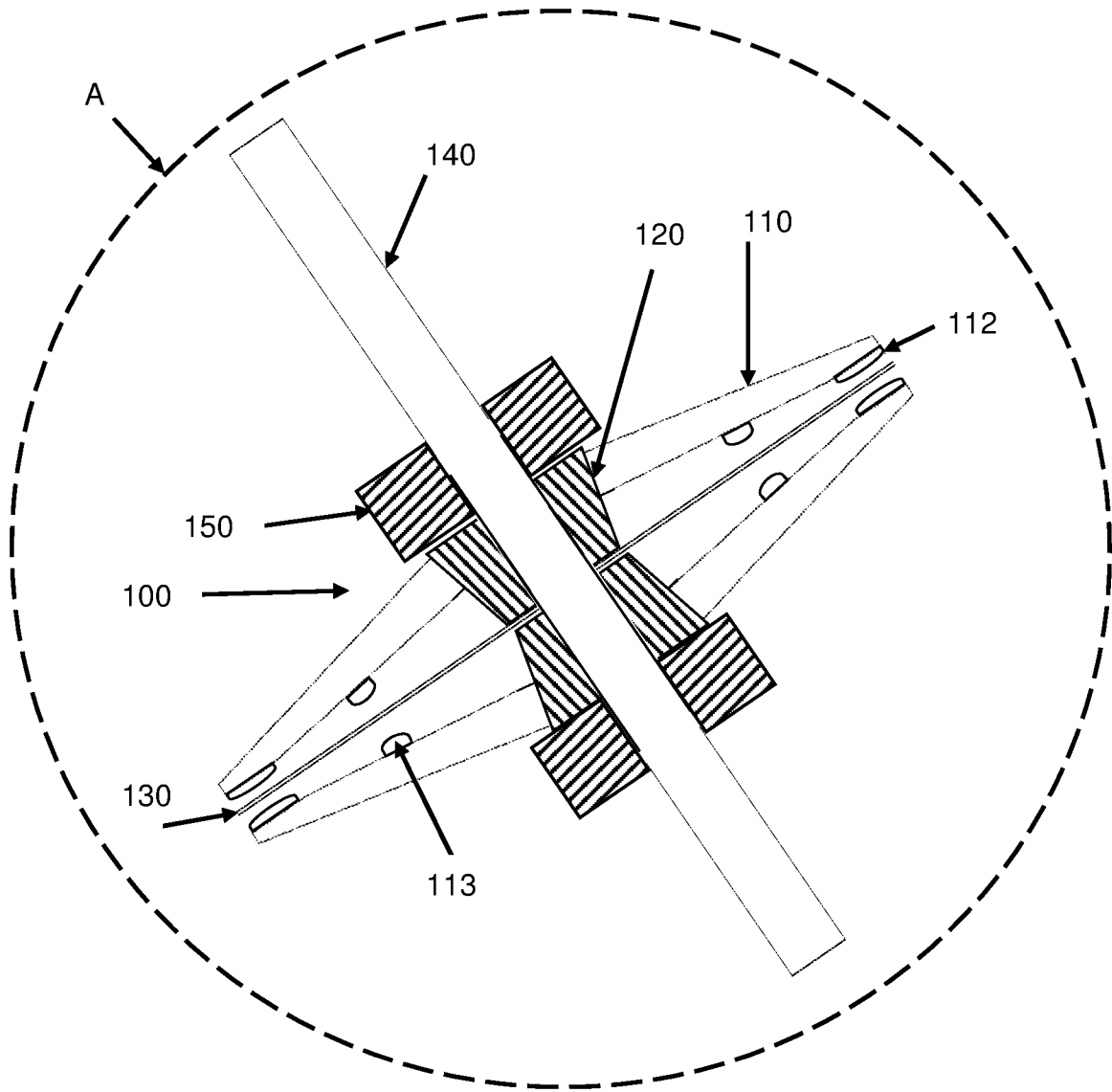

Fig. 6a

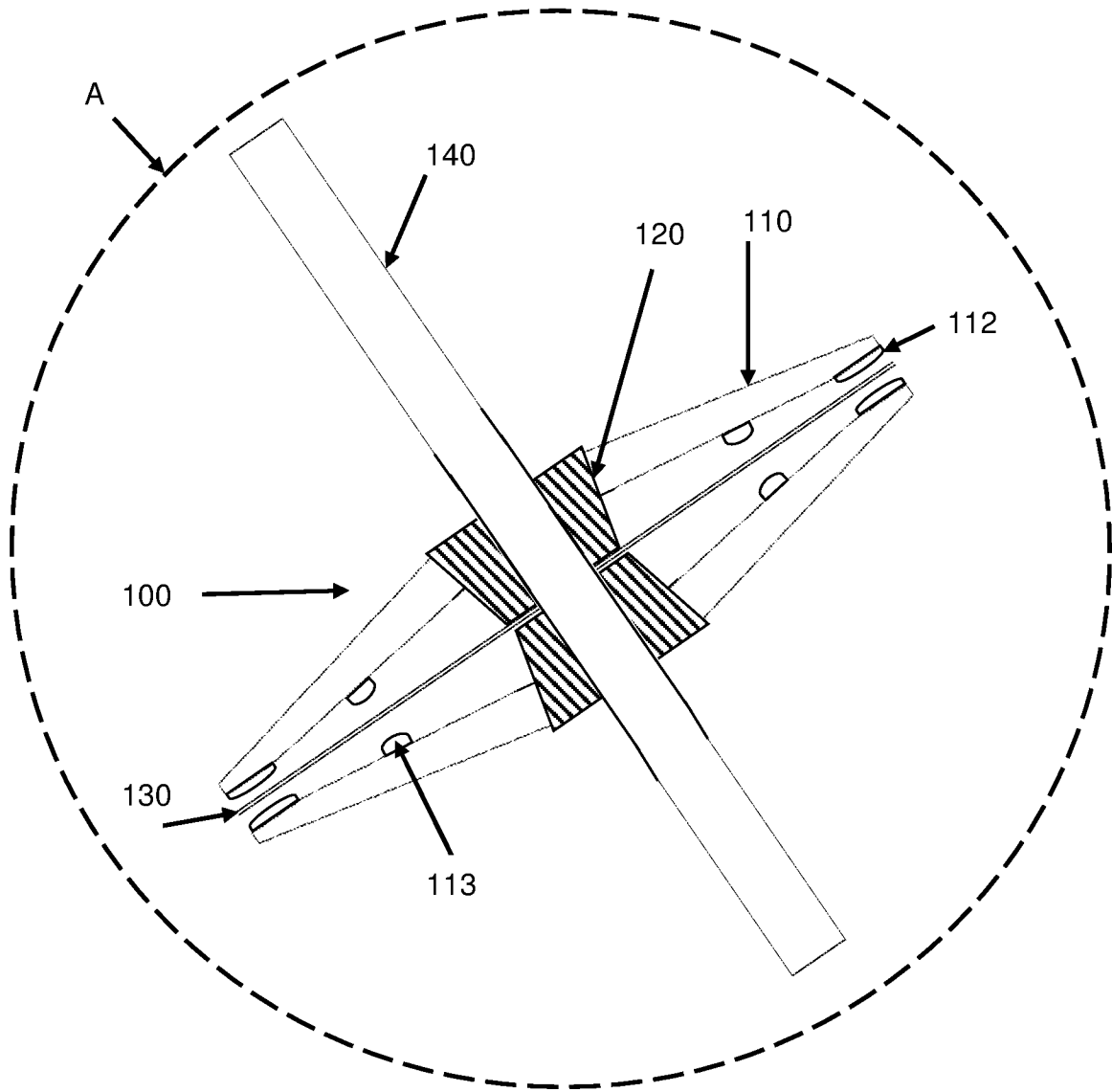

Fig. 6b

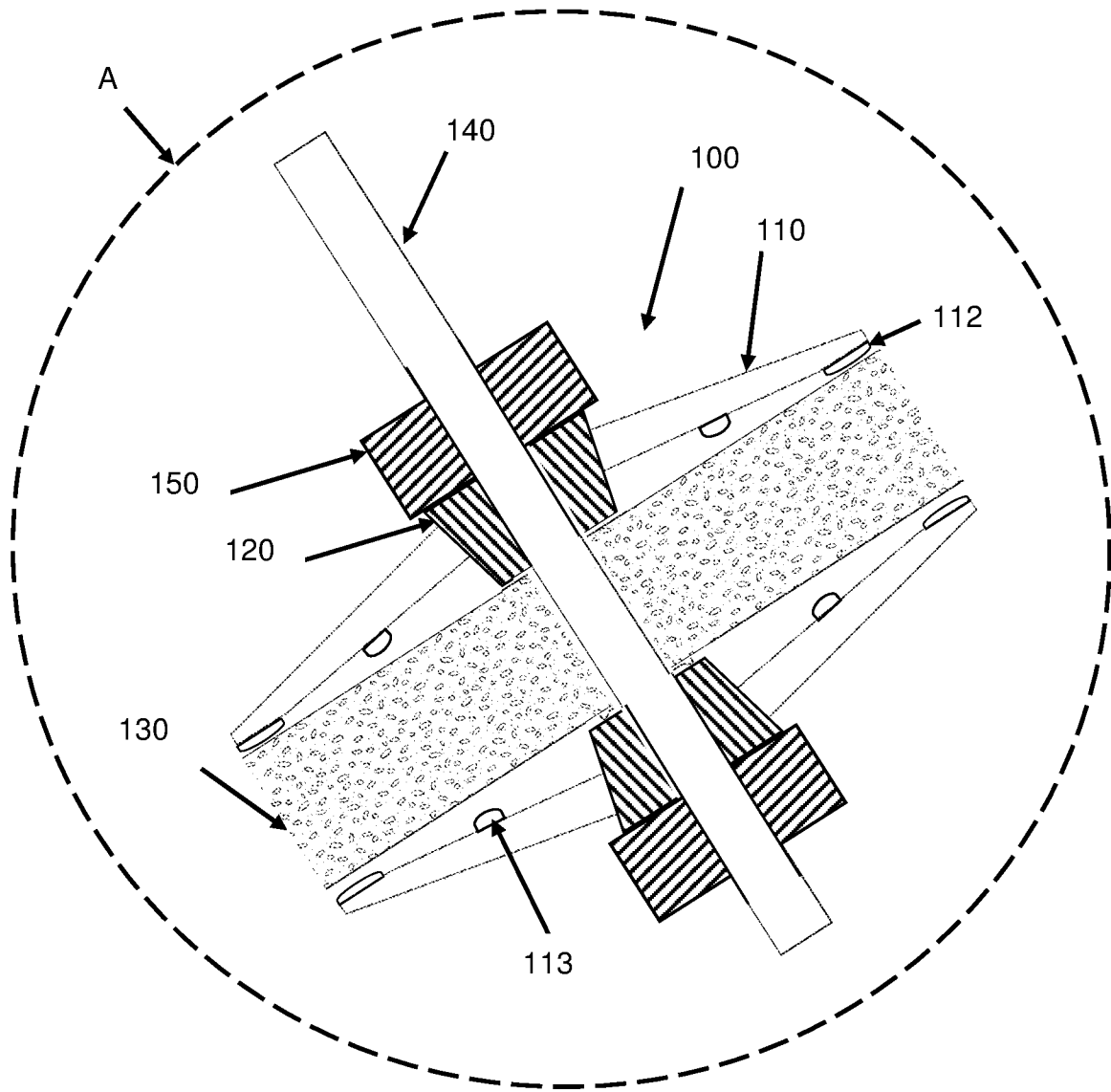

Fig. 7a

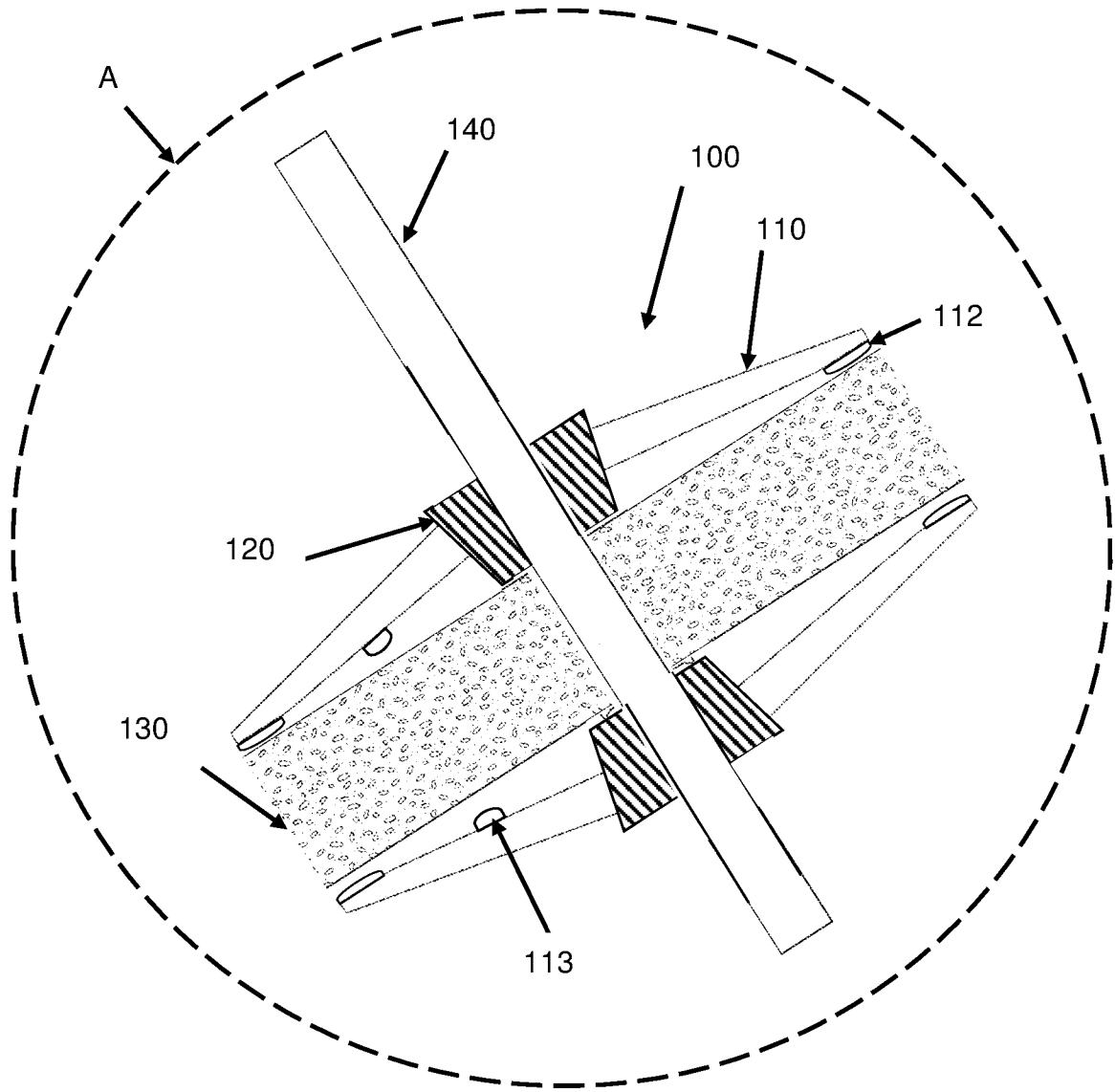

Fig. 7b

# INTERNATIONAL SEARCH REPORT

International application No  
**PCT/NO2023/060104**

<b>A. CLASSIFICATION OF SUBJECT MATTER</b> <b>INV. E21D11/05 E21D11/38 F16B5/02 F16B43/00 E21D21/00</b> <b>ADD.</b>		
According to International Patent Classification (IPC) or to both national classification and IPC		
<b>B. FIELDS SEARCHED</b> Minimum documentation searched (classification system followed by classification symbols) <b>E21D F16B</b>		
Documentation searched other than minimum documentation to the extent that such documents are included in the fields searched		
Electronic data base consulted during the international search (name of data base and, where practicable, search terms used) <b>EPO-Internal</b>		
<b>C. DOCUMENTS CONSIDERED TO BE RELEVANT</b>		
Category*	Citation of document, with indication, where appropriate, of the relevant passages	Relevant to claim No.
<b>A</b>	<b>NO 20 171 905 A1 (JOHN OLDROYD CHEETHAM [NO]) 30 May 2019 (2019-05-30) cited in the application figures 2-10 the whole document</b> -----	<b>1</b>
<b>A</b>	<b>NO 337 607 B1 (SOERBYE EVEN HELLY HANSEN [NO]) 9 May 2016 (2016-05-09) the whole document</b> ----- <div style="text-align: right;">-/--</div>	<b>1</b>
<input checked="" type="checkbox"/> Further documents are listed in the continuation of Box C. <span style="margin-left: 200px;"><input checked="" type="checkbox"/> See patent family annex.</span>		
* Special categories of cited documents :		
"A" document defining the general state of the art which is not considered to be of particular relevance "E" earlier application or patent but published on or after the international filing date "L" document which may throw doubts on priority claim(s) or which is cited to establish the publication date of another citation or other special reason (as specified) "O" document referring to an oral disclosure, use, exhibition or other means "P" document published prior to the international filing date but later than the priority date claimed	"T" later document published after the international filing date or priority date and not in conflict with the application but cited to understand the principle or theory underlying the invention "X" document of particular relevance; the claimed invention cannot be considered novel or cannot be considered to involve an inventive step when the document is taken alone "Y" document of particular relevance; the claimed invention cannot be considered to involve an inventive step when the document is combined with one or more other such documents, such combination being obvious to a person skilled in the art "&" document member of the same patent family	
Date of the actual completion of the international search	Date of mailing of the international search report	
<b>23 February 2024</b>	<b>05/03/2024</b>	
Name and mailing address of the ISA/ European Patent Office, P.B. 5818 Patentlaan 2 NL - 2280 HV Rijswijk Tel. (+31-70) 340-2040, Fax: (+31-70) 340-3016	Authorized officer  <b>van Berlo, André</b>	

## INTERNATIONAL SEARCH REPORT

International application No  
PCT/NO2023/060104

C(Continuation). DOCUMENTS CONSIDERED TO BE RELEVANT		
Category*	Citation of document, with indication, where appropriate, of the relevant passages	Relevant to claim No.
A	<p>2022 -Utgave Januar ET AL: "Teknisk Datablad", , 31 January 2022 (2022-01-31), XP093134403, Retrieved from the Internet: URL:https://oldroyd.no/uploads/dokumenter/ TDS-OLDROYD [retrieved on 2024-02-23] showing inner and outer ring; figure 2 -----</p>	1

# INTERNATIONAL SEARCH REPORT

Information on patent family members

International application No

**PCT/NO2023/060104**

Patent document cited in search report	Publication date	Patent family member(s)	Publication date	
<b>NO 20171905</b>	<b>A1</b>	<b>30-05-2019</b>	<b>EP 3717744 A2</b>	<b>07-10-2020</b>
			<b>WO 2019108068 A2</b>	<b>06-06-2019</b>
-----				
<b>NO 337607</b>	<b>B1</b>	<b>09-05-2016</b>	<b>NONE</b>	
-----				