

May 2, 1933.

C. T. JACOBS

1,906,607

METHOD AND APPARATUS FOR THE PRODUCTION OF MUSIC

Original Filed April 20, 1931 2 Sheets-Sheet 1

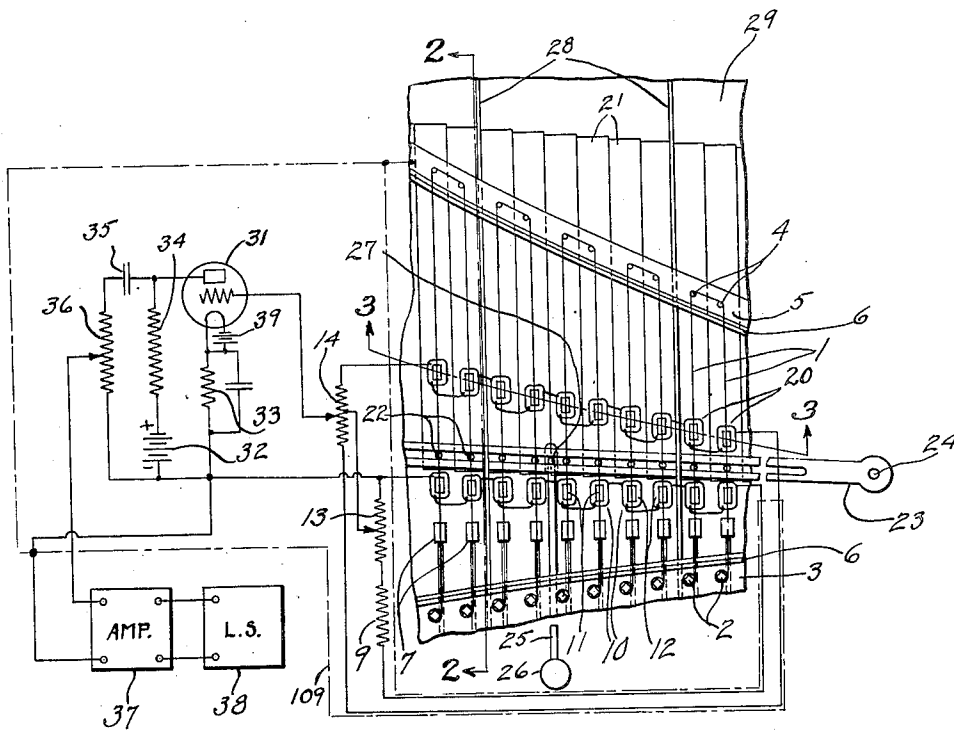

Fig. 1

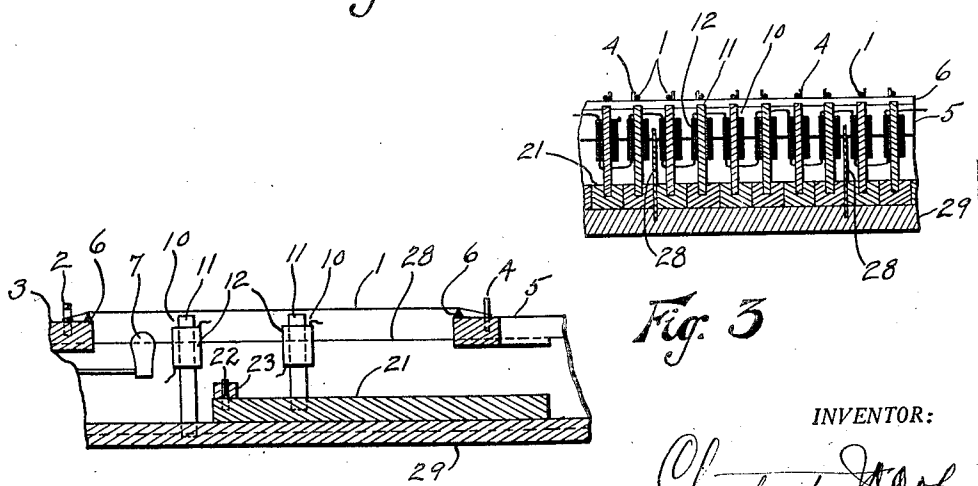

Fig. 2

Fig. 3

INVENTOR:

Charles T. Jacobs

May 2, 1933.

C. T. JACOBS

1,906,607

METHOD AND APPARATUS FOR THE PRODUCTION OF MUSIC

Original Filed April 20, 1931 2 Sheets-Sheet 2

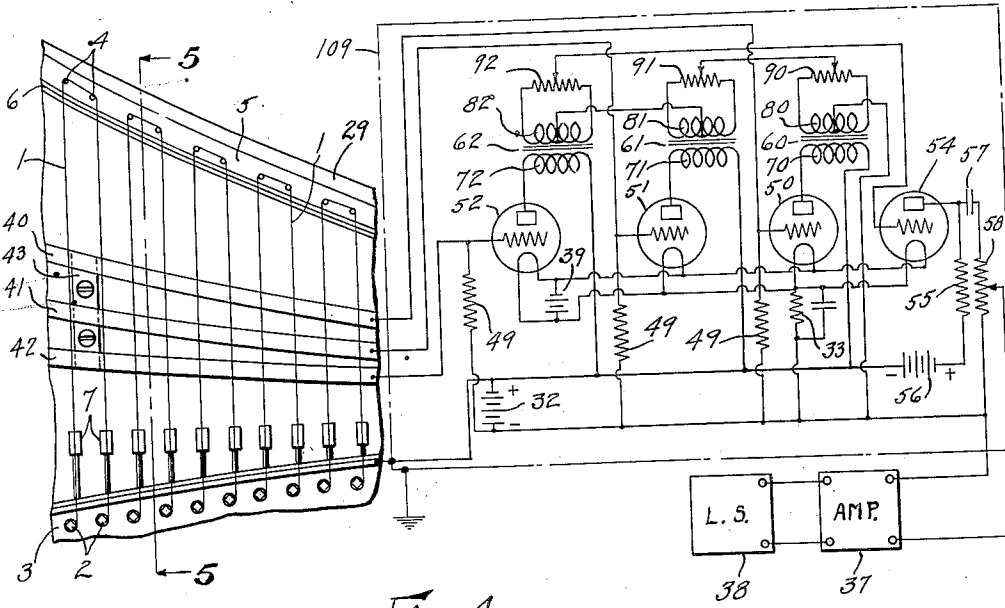

Fig. 4

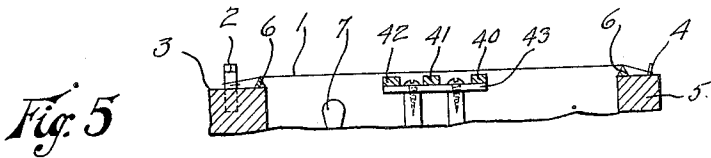

Fig. 5

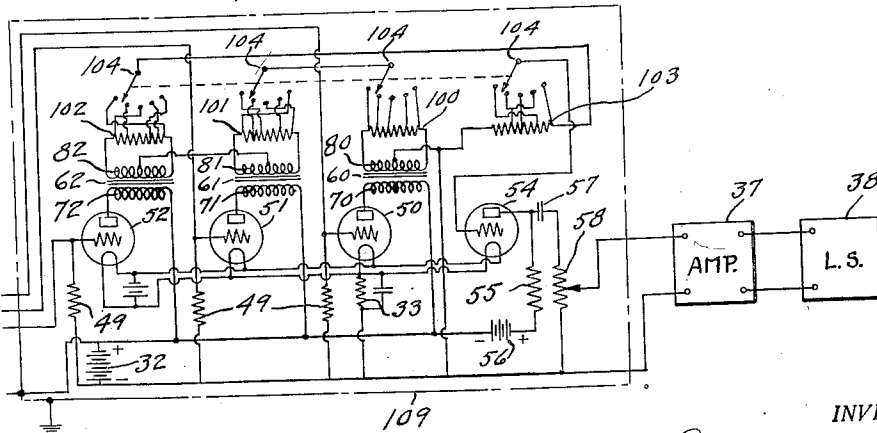

Fig. 6

INVENTOR:

Charles T. Jacobs

UNITED STATES PATENT OFFICE

CHARLES T. JACOBS, OF NEW PROVIDENCE, NEW JERSEY, ASSIGNOR TO MIESSNER INVENTIONS, INC., A CORPORATION OF NEW JERSEY

METHOD AND APPARATUS FOR THE PRODUCTION OF MUSIC

Application filed April 20, 1931, Serial No. 531,441. Renewed June 2, 1932.

This invention relates to musical instruments and systems, with particular reference to those in which the vibrations of mechanical vibrators are translated into electric oscillations. Mechanical vibrators as contemplated in the invention are those whose vibration contains not only a fundamental frequency component but also coincident higher frequency components harmonically related to the fundamental. The fundamental and these higher frequency components may each be termed a partial of the composite vibration. Typical of such vibrators are, of course, strings under longitudinal tension; and strings are shown as the vibrators in the accompanying drawings. I do not wish to limit my invention to use with strings, however, it being adaptable for use with any other such mechanical vibrator as above mentioned.

It is an object of my invention to provide methods and means for translating the vibration of mechanical vibrators into electric oscillations of a harmonic structure selectable within wide limits. It is a further and allied object to provide methods and means for selectively varying over a large range the harmonic structure or waveform of electric oscillations produced by translation of the vibration of mechanical vibrators.

A further object is the provision in a musical instrument of the class described of vibration-oscillation translating methods and means suitable for producing almost any desired quality of tone. A still further object is the provision in such an instrument of vibration-oscillation translating methods and means suitable for producing a quality of tone selectively variable over a wide range.

A further object is the provision of such means characterized by relatively low susceptibility or sensitivity to stray electrostatic and electromagnetic fields. A general object is the provision of an improved electrical musical instrument, by which music of widely variable tone quality may be produced. Other and allied objects will more fully appear from the accompanying drawings and the appended claims.

In the detailed description of my invention, hereinafter set forth, reference is had to the accompanying drawings, of which:—

Figure 1 is a combined plan and schematic view of a portion of a musical instrument embodying my invention in one form;

Figures 2 and 3 are cross-sectional views taken along lines 2—2 and 3—3 in Figure 1, respectively;

Figure 4 is a combined plan and schematic view of a portion of a musical instrument embodying my invention in the preferred form, modified from that shown in Figures 1, 2 and 3 in respect of the translating devices and of the electrical controls;

Figure 5 is a cross-sectional view taken along line 5—5 in Figure 4; and

Figure 6 is a schematic view illustrating a further modification of my invention in respect of the electrical controls.

It is well known that when the vibration of a mechanical vibrator comprises a series of harmonically related partial components (of which the fundamental frequency component may be considered as the first partial, its octave the second, etc.), for any given such partial component except the fundamental there will be found on or in the vibrator one or more positions where there takes place no vibration at the frequency of that partial, such positions being known as nodes for that partial; likewise that there will be found, for the fundamental as well as other partials, one or more positions of vibration maxima of substantially similar absolute values, such positions being known as loops or anti-nodes. Thus in the case of a vibrating string the number of anti-nodes for any given partial is equal to the index of that partial—i. e., there are two anti-nodes of second partial vibration, three of third etc.—and the number of nodes, exclusive of the ends of the strings, is equal to one less than such partial index.

At positions on or in the vibrator other than the nodes and anti-nodes for any given partial, intermediate amplitudes of vibration at the frequency of such partial take place. In the case of a vibrating string of active length L , the instantaneous dis-

placement D_n from mean position due to N^{th} harmonic vibration, of a given point distant by P from one end of the string, is related in the following manner to the similar coincident displacement E_n of the anti-node for such partial vibration which is nearest such end of the string:—

$$D_n/E_n = \sin(180^\circ \cdot N \cdot P/L) \dots (1)$$

It will be noted that the expression may assume a positive or a negative algebraic sign: such signs denote respectively similar or opposite directions of the two displacements D_n and E_n . Consideration of the expression will also show that in the vibration of the string at any given partial frequency, no involved phase relations exist between the vibrations of different points: thus any two points vibrate exactly in phase or exactly opposed in phase with respect to each other, and the instant of peak amplitude of the N^{th} partial vibration of one point is likewise an instant of peak amplitude of such partial vibration of all other points. Consequently expression (1) may be considered as showing the ratio of the N^{th} partial peak vibration amplitude at a given point to the N^{th} partial peak vibration amplitude at the first N^{th} partial antinode, a positive or negative value indicating respectively exact phase coincidence or opposition of the vibrations of the two points. Expression (1) of course in no way defines the relationships existing in a vibrating string between different partial components. Such relationships are established by a particular mode of vibration which results from the characteristics of the string itself, the manner of exciting it, etc., as is well understood by those skilled in the art.

It is further well known, and by way of example may be readily deduced for a string from the expression (1) above, that at different positions on or in a mechanical vibrator vibrating in any given mode there are an infinite number of combinations of relative vibration amplitudes between the various partial components. Thus if a mechanico-electric translating device be employed to translate the vibrations, first of one point on or in the vibrator, then of another, etc., into electric oscillations, and if these oscillations be translated into sound waves, changes in the tone quality of the sound produced will be apparent as such point of translation is changed. It will be found, however, that despite the availability of an infinite number of harmonic structures in electric oscillations or in sound waves produced in this manner, a larger order of infinity is required to express those incapable of production; and if this method alone be employed for the control of output tone in an electrical musical instrument, the

range of tone qualities available is quite limited.

I have discovered, however, that changes of wider scope and of greater significance, particularly from a musical point of view, in oscillation and sound harmonic structure can be obtained by employing a plurality of devices, each to translate into electric oscillations the vibration of a different point on or in the vibrator, by controlling and varying as between themselves the relative amplitudes of the composite oscillations produced by each device, and by thereafter combining the oscillations in an algebraically additive or subtractive manner each with respect to the others. I have further found that the flexibility of any such arrangement may be further increased by making variable and varying the position of one or more of such points of translation.

Thus in Figure 1, I show in plan view a plurality of vibrators 1, which may be strings of magnetic material, parallel and in a horizontal plane for example, strung under tension between tuning pins 2 in plank 3 and pins 4 in rear block 5, over triangular bars 6 which physically define the active vibratory lengths of the strings 1. Hammers 7 may be provided underneath the strings for vibrating the latter. Centered under each string at a similar fractional distance, shown for example as $5/7$, of its active length from the rear end thereof appears a translating device 10, the position of which may be fixed. Each such device may comprise for example a simple vertical bar magnet 11 with its upper pole slightly below the associated string 1, and with a coil 12 surrounding magnet 11 near such upper pole. The coils 12 of the several devices 10 may be electrically connected in series and across high resistance potentiometer 13 and equally valued resistance 9 in series.

Also underneath each string 1 but nearer its rear end appears another similar translating device 20, the coils of the several devices 20 being electrically connected in series, similarly to coils 12, and across center-tapped potentiometer 14, each half of which may have a resistance value equal to that of potentiometer 13 and of resistance 9. Instead of being fixed in position, however, each device 20 is mounted at its lower extremity to a block 21, slidable on base 29. On the top and near the front extremity of each block 21 may be provided a vertical pin 22, slidingly engaged in the long slot in slotted bar 23, which latter is pivoted as at 24. When the bar 23 is moved about its pivot, as may be done by the aid of handle 26 and rod 25 hooked into the slot in bar 23 as at 27, the several blocks 21 are moved forward and backward. This effects a change in the position of each of the translating

devices 21 longitudinally with respect to its associated string 1. Sideward motion of the bars 21 is prevented by a plurality of vertical members 28 mounted to base 29, the members 28 also if desired forming supports for block 5 and plank 3.

The motion of the several blocks 21 in the arrangement shown will be seen to be greater, the longer the associated string; and, for the customary progression of string lengths useful in the production of successive notes of the equally-tempered chromatic scale, the point of pivoting of slotted bar 23 can usually be so chosen as to provide distances of motion of the several blocks 21 almost exactly proportional to the active vibratory lengths of the respectively associated strings. It is desirable so to mount the several translating devices 20 on the several blocks 21 that their fractional distances from the rear ends of the active vibratory portions of the respectively associated strings are similar when bar 23 is in some given position, such as that shown in Figure 1. As shown each device 20 is centered under its associated string at a distance, from the rear end of the active vibratory length of the latter, of approximately $45/100$ of such length. If the motions of the several blocks 21 are made proportional to the active vibratory lengths of the associated strings, as above mentioned, this fractional distance may be uniformly altered for the several strings by motion of bar 23.

In Figure 1 I also show schematically further electrical apparatus. Thus thermionic vacuum tube 31 may be provided, supplied with anode current by battery or other source 32, and its cathode or filament excited as by battery 39. The flow of its anode current through condensively bypassed resistor 33 may serve suitably to bias its grid with respect to its cathode. The grid circuit of tube 31 includes a selectable portion of either half of the total resistance of center-tapped potentiometer 14 and a selectable portion of the total resistance of potentiometer 13. A. C. voltages appearing in the anode circuit of tube 31 are applied across resistor 34 and through stopping condenser 35 to potentiometer 36, by the manipulation of which a selectable percentage of such voltages may be applied to the input of the amplifier 37. Finally a loud-speaker or other electro-acoustic translating device 38 may be connected to the output of amplifier 37.

Consideration being given to the manner of functioning of the apparatus shown in Figure 1, it will be seen that each string 1 has associated therewith two translating devices, one device 10 and the other 20. Each of these translates the vibration of the point of the string 1 under which it is centered into substantially corresponding elec-

tric oscillations in its coil, due to the vibration of the string point in the field of the magnet of the device and the intersection of the coil by this field. As a result of the electrical connections, through other coils of each coil 10 to potentiometer 13 and of each coil 20 to potentiometer 14, vibration of any string 1 will cause an A. C. voltage to appear across each of the potentiometers 13 and 14. Each of these voltages may be considered to have a harmonic structure similar to that of the vibration of the string point producing it, and the phase relations between any given partial component in the two voltages may be considered similar to the phase relations between the corresponding partial component in the vibrations of the two string points.

Considering any of the strings 1 to be caused to vibrate in a given mode, as by a certain blow imparted by its associated hammer 7, let us denote by A_1 the amplitude of fundamental component of the A. C. voltage which would be produced across its potentiometer and resistance by a translating system similar to devices 10, potentiometer 13 and resistance 9, but positioned under the strings at their centers—the only anti-node for the fundamental component. Likewise let us denote by A_2 the amplitude of second partial component of the voltage which would be produced by a similar translating system positioned at the first anti-node from the rear end of each of strings for the second partial; by A_3 the amplitude of third partial component produced by a similar translating system positioned at the like anti-node for the third partial, etc. Then by virtue of expression (1) and of the correspondence of the electric oscillations to the string point vibrations from which they are translated, there may be compiled the following table of peak amplitudes for the various partial components of the voltage produced across potentiometer 13 and resistance 9 by the translating devices 10, for which P/L is $5/7$, the respectively positive or negative algebraic signs indicating phase coincidence or opposition between the values shown and the respectively corresponding "A" values:—

Table 1

Fund.,	.782 A_1	4th H.,	.433 A_4	7th H.,	.000 A_7
2nd H.,	-.975 A_2	5th H.,	-.975 A_5	8th H.,	-.782 A_8
3rd H.,	.433 A_3	6th H.,	.782 A_6	9th H.,	.975 A_9 etc.

Due to the division of voltage between resistor 9 and potentiometer 13, half of each of these voltage components appears across the latter; and by virtue of the sliding contact of the potentiometer there may be applied to the grid of tube 31 either such half or any desired smaller fractional part of each of such components.

For any given position of the translating devices 20, longitudinally with respect to strings 1, there may be compiled a similar table of partial components of the voltage appearing across potentiometer 14. Thus if the devices 20 are located at 45/100 of the active length of each string from the rear end thereof, P/L becomes 45/100 and the tables becomes:—

Table 2

Fund.	.988 A ₁	4th H.	-.588 A ₄	7th H.	-.454 A ₇
2nd H.	.309 A ₂	5th H.	.707 A ₅	8th H.	-.951 A ₈
3rd H.	-.891 A ₃	6th H.	.809 A ₆	9th H.	.156 A ₉
					etc.

wherein the symbols A₁, A₂, A₃ etc., have the identical significance with those in the preceding table. Due to the arrangement of center-tapped potentiometer 14, there may be applied to the grid of tube 31 half or any desired smaller fractional part of each of such components; or such half or smaller fractional part may be applied to the grid with all components reversed in phase—i. e., with the sign of each changed—as will be understood. Thus by virtue of the setting of the contacts of potentiometers 13 and 14, voltages corresponding to either the sum or difference of half of Table 1 and half of Table 2, or of any smaller fractional part of either or both, may be applied to the grid of tube 31. Furthermore by virtue of the movability of translating devices 20, Table 2 may be replaced with an infinite number of other tables.

Tube 31 may therefore be actuated by a total A. C. voltage of fundamental frequency similar to that of the vibration of the particular string 1, but of harmonic content widely variable in amplitude between any and all the components. The exact amplitude relationships among the several components are, of course, dependent on the relative values of A₁, A₂, A₃, etc., which in turn depend on the characteristics of the particular string and on the manner of its excitation; but the variations discussed above are available for any given set of inter-partial vibration amplitude relationships, as will be understood. It will be obvious, of course, that upon the simultaneous vibration of a plurality of strings 1, tube 31 will be actuated by the simple algebraic additions of the voltages actuating it upon vibration of each of such strings separately. The voltage actuating tube 31 is thereby amplified, may be controlled in amplitude by potentiometer 36, amplified to any extent desired as by amplifier 37. and converted into sound by loudspeaker 38.

It will be understood that an appreciable change in oscillation harmonic structure, and in the quality of tone produced by translation thereof into sound, may be obtained simply by the movement of translat-

ing devices 20 in Figure 1, but without control of relative amplitudes or phases between the oscillations or voltages produced by the row of translating devices 10 and those produced by row of devices 20. It will further be apparent that the particular means which I have disclosed for moving the several translating devices 20 is applicable to the case wherein only one such device per vibrator or string is employed.

In Figures 1 and 3 I show each of the rows of coils 10 and 20 electrically connected within themselves in a certain manner. This is such that, viewing the coils say from the top, an electric impulse passing through either of the two series of coils will travel in a clockwise direction in one coil, counterclockwise in the next, clockwise in the next, etc. As shown in the figures, the coils are similarly wound, similarly terminalled and similarly mounted; and the top of one is connected to the top of the next, the bottom of this to the bottom of the next, the top of this to the top of the next, etc. This greatly reduces the susceptibility or sensitivity of the series of coils to stray electromagnetic fields such as those emanating from nearby power apparatus. Such fields as they intersect two adjacent coils, which are very close together, are almost identical in strength and configuration and hence induce similar voltages in the two coils, which voltages are caused to buck each other by the arrangement shown. I prefer, although I have not found it imperative, similarly to pole all the magnets of the devices in each one series:—e. g., to mount all with north poles up.

It will be understood of course that wide modifications may be made from the exact arrangements shown and described, many of which latter can be only illustrative. Thus the fixed translating devices 10 may be positioned at other points than at 5/7 of active string length from the rear end thereof, this particular position having been chosen only by way of example; the translating devices 20 may be fixed in some one position, the bars 21 and associated apparatus for moving them being omitted; a greater number of translating devices per vibrator may be employed; etc. Thus in Figure 4 I show my invention in what, for simplicity of construction, I conceive to be a preferred form. This form involves modifications from Figures 1, 2 and 3 which include the substitution of electrostatic translating devices for the electromagnetic devices of preceding figures; the employment of a larger number of translating devices per vibrator than previously illustrated, each being fixed; the use of a separate thermionic tube following each translating device or series thereof; and a rearrangement of the electrical controls, appropriate to the other modifications.

In Figure 4 strings 1, tuning pins 2, plank 3, pins 4, rear bar 5, triangular bars 6 and hammers 7 are shown as before. In this case the strings need not necessarily be of magnetic material but should be electrically conductive; and one or both triangular bars 6 may conveniently be made electrically conductive, in order to connect the strings together electrically. Instead of the rows of translating devices 10 and 20 of preceding figures, a plurality of electrically conductive bars, as 40, 41 and 42, may be disposed underneath the strings, each slightly separated from the strings so that under conditions of maximum vibration of any string the latter will not quite touch any of the bars. In Figure 5, a cross-sectional view taken along the line 5—5 of Figure 4, the bars 40, 41 and 42 may be seen to be mounted on one or more insulating strips 43 and thereby insulated from other parts of the apparatus. The top center line of each bar may pass under each string at a similar fractional part of its active length from the rear end thereof. Thus as shown in Figure 4, the top center-line of bar 40 passes under a point on each string distant $4/10$ of the active length from the rear end of the latter; that of bar 41 under a point on each string distant $8/15$ of the active length from the rear end of the latter; and that of bar 42 at $9/14$ position. It will be understood, however, that other positions for the bars, or more or less than three bars, may be employed as desired. A base 29 may be provided underneath and supporting the mechanical apparatus shown in Figure 4.

For each bar 40, 41 and 42 there may be provided a thermionic vacuum tube. Such tubes are shown in Figure 4 as 50, 51 and 52; and each bar may be electrically connected to the grid of its associated tube. The cathodes or filaments of the tubes may be connected together and energized as by battery 39. Between the cathodes and the negative terminal of battery or other anode current source 32 may be provided a condensively by-passed resistor 33 for the biasing of the grid of each tube, through its associated high resistance 49, negatively with respect to its cathode. The anodes of the tubes 50, 51 and 52 may be connected to the positive terminal of battery or other source 32, through the respective primaries 70, 71 and 72, of the respective transformers 60, 61 and 62. A D. C. potential difference between the bars 40, 41, 42 and the strings 1 may be established by connecting one of the triangular bars 6 to a point different in potential from the grids of tubes 50, 51, and 52; and this point may conveniently be the positive terminal of battery or source 32.

Across the center tapped secondaries 80, 81 and 82 of the respective transformers 60,

61 and 62 are provided potentiometers 90, 91 and 92, preferably similar; and the two terminals formed by the center tap of secondary 80 and the sliding contact of potentiometer 90, the two formed by the tap of secondary 81 and contact of potentiometer 91, and the two formed by the tap of secondary 82 and potentiometer 92, are connected together in series and form an input circuit for thermionic vacuum tube 54. The cathode or filament of this tube may conveniently be paralleled with those of tubes 50, 51 and 52; and its anode current may be supplied through resistor 55 from battery or source 32, augmented by additional source 56, is desired, as will be understood. A. C. voltages appearing across resistor 55 are applied through condenser 57 and potentiometer 58 to amplifier 37, the output of which may actuate loudspeaker 38, as in Figure 1.

Consideration being given to the manner of functioning of the apparatus shown in Figure 4, it will be seen that between each string 1 and each bar 40, 41, 42, a small electrostatic capacity exists; and that each such capacity, in parallel with similar capacities formed by the same bar with other strings 1, forms a series circuit with one of the resistors 49 and battery or source 32. Upon vibration of any string 1 the capacity between bar 40 and the region of the string above bar 40 will vary oscillatorily; and this capacity variation produces an A. C. voltage across the resistor 49 at the input of tube 50, which voltage substantially corresponds to the vibration of the point of the vibrated string 1 above the center of bar 40. This action is similar to that of the well known condenser microphone, as will be understood. Similarly a voltage substantially corresponding to the vibration of the point in the vibrated string 1 above the center of bar 41 will appear at the input of tube 51, and a voltage corresponding to the vibration of the string point above the center of bar 42 at the input of tube 52. These voltages, in amplified form, respectively appear across the secondaries 80, 81 and 82.

By virtue of the connections between the center taps of the secondaries 80, 81, 82 and the movable contacts of the potentiometers 90, 91, 92, a portion of each of such voltages, regulable in each case from half to none, may be applied to the grid of the tube 54; and the phase of any one or more of these voltages may be reversed with respect to that of the others, as will be understood. The composite voltage thus applied to the grid of tube 54 is thereby amplified and appears across resistor 55 and through stopping condenser 57 across potentiometer 58. By this latter its general amplitude may be controlled and it may thereafter be amplified

by amplifier 37 and translated into sound by loudspeaker 38.

The underlying principles of control and combination of A. C. voltages produced by each of the plurality of translating devices associated with the several strings—i. e., bars 40, 41 and 42—are identical with those outlined above for the two rows of electromagnetic translating devices. In Figure 4 such voltages are amplified by tubes 50, 51 and 52 before being controlled and combined, but this is incidental only and in no way affects the principles involved, providing intermediate and different phase shifts by the respective circuits of transformers 80, 81 and 82 are avoided. This may readily be done by proper and similar design of these transformers, as will be understood. Also in Figure 4 three separate voltages are produced and combined—this may be resolved merely into algebraic addition of three tables of partial components instead of two as for Figure 1, each one table being first subject to multiplication by some given positive or negative fraction, depending on the setting of one of the potentiometers.

In the case either of the arrangements shown in earlier figures or of that shown in Figures 4 and 5, various combinations of settings of the several electrical controls (and of the mechanical control 26 in Figure 1) will produce a wide variety of oscillation harmonic structures or waveforms and, upon translation by loudspeaker 38, of sound tone quality. Combinations may be found whereby odd partials are emphasized, others whereby even partials are emphasized, others whereby certain ranges of partials are suppressed and intermediate ranges emphasized, others whereby various combinations of partials may be simultaneously eliminated, etc. It may be desired, however, to restrict to a readily selectable few the harmonic structures and tone qualities to be produced, these corresponding for example to the tone qualities of certain selected well-known musical instruments. In this case certain modifications may advantageously be made in the control system, such as I have shown in Figure 6.

Subject to these modifications, Figure 6 is similar to the schematic electrical portion of Figure 4; and it is intended to be capable of substitution therefor in Figure 4. In Figure 6 the secondaries 80, 81 and 82 are seen to be shunted by tapped resistors 100, 101 and 102 respectively, preferably of high and equal total value; and taps on each of these resistors are connected to the several contacts of a single-pole, multi-contact switch 104, the group of such three switches 104 being operated in tandem. The tapped resistors 100, 101 and 102 are thus substituted for the resistance elements of the potentiometers 90, 91 and 92 in Figure 4 and

the switches 104 for the sliding contacts thereof. The positioning of the taps on the resistances 100, 101, 102 and the manner of connection thereof to the several contacts of the switches 104 are conveniently determined by employing the circuit as shown in Figure 4, with potentiometers 90, 91 and 92, having total resistance equal to that of the resistors 100, 101 and 102 to be substituted therefor. The settings of the sliding contacts of the three potentiometers are varied until a desirable quality of tone is effected and the respective settings thereupon duplicated by a corresponding tap on each of the resistors 100, 101 and 102. Such tap on each resistor is then wired, for example, to the leftmost contact of the switch 104 associated with that resistor. Another tone quality may be determined with the potentiometers and similarly duplicated by a tap on each of the three resistors wired to the next-to-left contact of the associated switches, and so on for as many different tone qualities, or oscillation harmonic structures, as may be desired or for as many taps as are available on each of the switches 104.

It frequently may happen that with different tone qualities as produced by various settings of the tandem switches 104 the apparent sound volume changes appreciably. To counteract this I have shown in Figure 6 another tapped resistance 103, with its taps wired to a fourth switch 104, similar to the other such switches. Across this resistance will be seen to be applied the voltages from the secondaries 80, 81 and 82 made available by resistors 100, 101 and 102 and the associated switches 104; and from this resistance by means of switch 104 there may be taken off and applied to the grid of tube 54 a selectable portion of such voltages. By such choice of the positions of the taps on resistor 103 and arrangement of connection thereof to the associated switch 104 as may readily be determined by test, this switch may be tandemed with the other three switches 104, the group then providing quality change without change of apparent volume, as will be understood. The tapped resistors shunted across the transformer secondaries may of course be replaced by taps directly on the secondaries if desired; or the tap-and-switch arrangement shown in Figure 6 may optionally be employed with a simpler circuit wherein no tubes 50, 51 and 52 separate it from the translating devices, such for example as with the circuit of Figure 1.

In Figures 4 and 6 I also show a ground connection to the potential of the strings 1, which is also the positive potential of the battery or source 32. This ground connection may signify not only an actually-connected ground, but also the connection to this potential, if desired, of a metallic base

such as may be employed for the electrical apparatus shown and of certain other such parts as it is frequently considered by those skilled in the art advisable to ground. This connection, although novel, I consider desirable in order that the strings 1 and such large metal parts as may be connected to them, all of which are frequently exposed, may not be at a dangerous potential with respect to ground.

Thus for example in Figures 4 and 6 I show schematically an electrostatic shield 109 grounded in this manner. It is usually desirable not only to shield the amplifier, but also to some extent at least the bars 40, 41 and 42 in Figure 4. To this end portions of the mechanical apparatus such as pins 4, rear bar 5 and base 29 may be made electrically conductive and rendered at the potential of strings 1 by successive contact with each other and the strings. Similarly in Figure 1, it may be found desirable to make electrically conductive pins 4, rear bar 5, vertical members 28 and base 29 and to connect one of these parts to shield 109 disposed about the electrical apparatus and leads.

In both Figures 1 and 4 the strings 1 are shown without dampers. It will be understood of course in either case that an individual damper, released by depression of the associated hammer-actuating key, may be employed for each string 1 if desired, in similar fashion to common piano practice.

Hammers have been shown as the means for vibrating strings 1 in all the figures. It is well known that variation of the velocity of the blow imparted by a hammer to a string will produce variation of the mode of vibration of the string—e. g., would produce different relative values of A_1 , A_2 , A_3 , etc., as employed in the illustrative mathematics above. Such inter-partial relationship changes, in combination with those produceable as I have outlined above, may be made by a skilled musician to yield extraordinarily diverse musical effects. I therefore intend to claim my invention not only without, but also with, means for varying the mode of vibration of the string or other vibrator.

While I have shown and described in detail the use of strings as the mechanical vibrators, it will be understood that other vibrators whose vibration comprises a series of harmonically related partial components may equally well be employed. Thus for example bars vibrated longitudinally, with translating devices suitably positioned with respect thereto, may be substituted for the strings as shown. I further do not wish to limit my invention to the electromagnetic and electrostatic translating devices; others are equally capable of employment therein. It will further be understood that the particular combinations of apparatus shown are

representative only, wide modifications thereof being possible without departing in manner of employment or in spirit from the scope of my invention. Thus the amplification provided by 50, 51 and 52 may be dispensed with in the circuits shown in Figures 4 and 6; such amplification may be provided in the circuit of Figure 1; other modifications may be made as hereinabove suggested, etc., as will be understood. Finally the invention may of course be employed in any case, with the omission of all variable controls, for the production of oscillations and tones of a particular harmonic structure, such for example as may be incapable of production by the aid of a single translating device.

I claim:—

1. The method of producing a musical tone and of varying its harmonic structure, which includes generating a plurality of series of electric oscillations of the same fundamental frequency and of respectively different harmonic structures, in varying the relative phases of the oscillations of the several said series, and in combining said oscillations.

2. The method of producing a musical tone and of varying its harmonic structure, which includes generating a plurality of series of electric oscillations of the same fundamental frequency and of respectively different harmonic structures, in varying the relative phases and amplitudes of the oscillations of the several said series, and in combining said oscillations.

3. The method of producing a musical tone and of varying its harmonic structure, which includes generating a plurality of series of electric oscillations of the same fundamental frequency and of respectively different harmonic structures, in varying the relative phases and amplitudes of the oscillations of the several said series, and in simultaneously translating said oscillations into sound.

4. The method of producing a musical tone and of varying its harmonic structure, which includes generating a plurality of series of electric oscillations of the same fundamental frequency and of respectively different harmonic structures, in varying the relative phases of the oscillations of the several said series, and in simultaneously translating said oscillations into sound.

5. The method of producing electric oscillations of particular harmonic structure from a mechanical vibrator, which consists in vibrating said vibrator at a plurality of its partial frequencies to produce in different portions of said vibrator vibrations respectively having different waveforms but the same fundamental frequency, in translating the vibrations of each of a plurality of such different portions of said vibrator into

a series of electric oscillations, and in combining the oscillations of the several such series.

6. The method of producing electric oscillations from a mechanical vibrator and of regulating their harmonic structure, which consists in vibrating said vibrator at a plurality of its partial frequencies to produce in different portions of said vibrator vibrations respectively having different waveforms but the same fundamental frequency, in translating the vibrations of each of a plurality of such different portions of said vibrator into a series of electric oscillations, in regulating the relative characteristics of said oscillations between the several such series, and in combining the so regulated oscillations.

7. The method of producing electric oscillations from a mechanical vibrator and of regulating their harmonic structure, which consists in vibrating said vibrator at a plurality of its partial frequencies to produce in different portions of said vibrator vibrations respectively having different waveforms but the same fundamental frequency, in translating the vibrations of each of a plurality of such different portions of said vibrator into a series of electric oscillations, in selectively regulating the relationships between the oscillations of the several such series in respect of at least one of the two characteristics, amplitude and phase, and in thereafter combining the oscillations of the several such series.

8. The method of producing electric oscillations from a mechanical vibrator and of regulating their harmonic structure, which consists in vibrating said vibrator at a plurality of its partial frequencies to produce in different portions of said vibrator vibrations respectively having different waveforms but the same fundamental frequency, in selectively regulating the mode of vibration of said vibrator, in translating the vibrations of each of a plurality of such different portions of said vibrator into a series of electric oscillations, and in combining the oscillations of the several such series.

9. In a musical instrument, a plurality of sources of electric oscillations of the same fundamental frequency and of respectively different harmonic structures; means for varying the relative phases of the oscillations from the several said sources; and means for combining said oscillations.

10. In a musical instrument, a plurality of sources of electric oscillations of the same fundamental frequency and of respectively different harmonic structures; means for varying the relative phases and amplitudes of the oscillations from the several said sources; and means for combining said oscillations.

11. In a musical instrument, a plurality of

sources of electric oscillations of the same fundamental frequency and of respectively different harmonic structures; means for altering the relative phases of said oscillations; and means for simultaneously translating said oscillations into sound.

12. In a musical instrument, a plurality of sources of electric oscillations of the same fundamental frequency and of respectively different harmonic structures; means for altering the relative phases and amplitudes of said oscillations; and means for simultaneously translating said oscillations into sound.

13. In a musical instrument, the combination of a plurality of systems each operable to produce sound of the same fundamental frequency and of respectively different harmonic structure; means for simultaneously operating said systems; and means for altering the relative phases of sounds respectively produced by the several said systems.

14. In a musical instrument, the combination of a plurality of systems each operable to produce sound of the same fundamental frequency and of respectively different harmonic structure; means for simultaneously operating said systems; and means for altering the relative phases and amplitudes of sounds respectively produced by the several said systems.

15. In a musical instrument, the combination of a tuned vibrator; a plurality of systems for translating the vibrations of respectively different portions of said vibrator into electric oscillations of respectively different harmonic structures but of the same fundamental frequency; a work circuit; and means interposed between said translating systems and said work circuit, and selective with respect to said translating systems, for applying the oscillations thereby produced to said work circuit.

16. In a musical instrument, a plurality of sources of electric oscillations of the same fundamental frequency and of respectively different harmonic structures; and selective means connected to said sources for combining the oscillations from the several said sources in any of a plurality of predetermined phase and amplitude relationships.

17. In a musical instrument, the combination of a mechanical vibrator, the vibrations of various portions of which inherently possess dissimilar waveforms but the same fundamental frequency; a plurality of mechanico-electric translating devices, each associated with a different portion of said vibrator and arranged to translate into a series of electric oscillations the vibration of such portion; and means for combining the oscillations of the several such series.

18. In a musical instrument, the combination of a mechanical vibrator, the vibrations

- of various portions of which possess inherently dissimilar waveforms but the same fundamental frequency; a plurality of mechanico-electric translating devices, each associated with a different portion of said vibrator and arranged to translate into a series of electric oscillations the vibration of such portion; selective means for varying the characteristics of the oscillations of the several such series relative to each other; and means following said selective means for combining the oscillation of the several such series.
19. In a musical instrument, the combination of a mechanical vibrator, the vibrations of various portions of which inherently possess dissimilar waveforms but the same fundamental frequency; a plurality of mechanico-electric translating devices, each associated with a different portion of said vibrator and arranged to translate into a series of electric oscillations the vibration of such portion; selective means for varying the relationships between oscillations of the several such series in respect of at least one of the two characteristics, phase and amplitude; and means following such selective means for combining the oscillations of the several such series.
20. In a musical instrument, the combination of a mechanical vibrator, the vibrations of various portions of which inherently possess dissimilar waveforms but the same fundamental frequency; a plurality of mechanico-electric translating devices, each for translating into a series of electric oscillations the vibrations of a therewith associated portion of said vibrator; means for associating said devices with respectively different portions of said vibrator, at least one of said means being selective to associate its said device selectively with any of a plurality of portions of said vibrator; and means for combining the oscillations of the several such series.
21. In a musical instrument of the class described, the combination of a plurality of tuned strings; means for vibrating said strings; a plurality of mechanico-electric translating systems, each system being associated with a portion of each string different from that with which each said other system is associated and being arranged to translate into a series of electric oscillations the vibrations of the therewith associated such portions; and means for combining the oscillations of the several such series.
22. In a musical instrument of the class described, the combination of a plurality of tuned strings; means for vibrating said strings at a plurality of their partial frequencies; a plurality of mechanico-electric translating systems, each for translating into a series of electric oscillations the vibrations of a therewith associated portion of
- each string; means for associating said systems with respectively different portions of each string, at least one of said means being selective to associate its said system selectively with any of a plurality of portions of each string; and electrical means for combining the oscillations of the several such series.
23. In a musical instrument of the class described, the combination of a plurality of tuned, electrically conductive strings; means for vibrating each of said strings; a plurality of electrical resistance elements; means for applying across each of said resistance elements electric oscillations corresponding to the vibration of a portion of each of said strings, said means comprising an electrically conductive bar for each of said resistance elements positioned adjacent and forming an electrical capacity with a portion of each string different from that to which each said other bar is adjacent, and an electrical circuit for each of said resistance elements including said element, the associated said bar and a source of D. C. potential; and means for combining such oscillations.
24. In a musical instrument the combination of a plurality of tuned vibrators; means for vibrating each of said vibrators at a plurality of its partial frequencies; means for varying the mode of such vibration; a plurality of translating systems, each system being associated with a portion of each vibrator different from that with which each said other system is associated and being arranged to translate into a series of electric oscillations the vibrations of the therewith associated such portions; and means for combining oscillations.
25. In a musical instrument, a plurality of sources of electric oscillations of the same fundamental frequency and of respectively different harmonic structures; selectively adjustable means connected to said sources for combining the oscillations from the several said sources in any of a plurality of predetermined phase and amplitude relationships; and means, linked to said first-mentioned means for adjustment therewith, for regulating the amplitude of said combined oscillations.
26. In a musical instrument of the class described, in combination, a plurality of tuned, electrically conductive vibrators; at least one electrically conductive member forming electrical capacities with said vibrators; electrical amplifying apparatus including at least one vacuum tube having a grid; a source of anode current for said vacuum tube, having at least two terminals; an electrical connection from said conductive member to said grid; and a connection from all of said vibrators to a terminal of positive D. C. potential on said source.
27. In a musical instrument of the class

described, in combination, a plurality of substantially parallel tuned strings; at least one mechanico-electric translating device positioned adjacent each of said strings and
5 arranged to translate into electric oscillations the vibration thereof; and means for changing the position of one of said translating devices associated with each string, said means comprising a plurality of slid-
10 able blocks adjacent each other and each carrying one of said translating devices, at least one fixed track for said blocks, a pin in each of said blocks, a pivoted arm, a slot in said arm engaging each of said pins, and
15 means for moving said arm about its pivot.

28. In a musical instrument of the class described, in combination, a plurality of tuned vibrators; a plurality of electromag-
netic translating devices for translating into
20 electric oscillations the vibrations of said vibrators, said devices including a plurality of substantially parallel coils; and electrical connections between said coils to form
25 thereof a series circuit wherein the passage of an electric impulse is reversed in direction in each succeeding coil.

CHARLES T. JACOBS.

30

35

40

45

50

55

60

65