

(19) World Intellectual Property Organization  
International Bureau



(43) International Publication Date  
20 November 2008 (20.11.2008)

PCT

(10) International Publication Number  
**WO 2008/140784 A1**

- (51) International Patent Classification:  
**B01J 25/00** (2006.01)
- (21) International Application Number:  
PCT/US2008/006001
- (22) International Filing Date: 8 May 2008 (08.05.2008)
- (25) Filing Language: English
- (26) Publication Language: English
- (30) Priority Data:  
60/928,946 11 May 2007 (11.05.2007) US
- (71) Applicant (for all designated States except US): **SDC MATERIALS, INC.** [US/US]; 940 S. Park Lane, Suite 2, Tempe, AZ 85281 (US).
- (72) Inventor; and
- (75) Inventor/Applicant (for US only): **BIBERGER, Maximilian, A.** [US/US]; 7346 E. Del Acero Drive, Scottsdale, AZ 85258 (US).
- (74) Agents: **OWENS, Jonathan, O.** et al.; HAVERSTOCK & OWENS LLP, 162 North Wolfe Road, Sunnyvale, CA 94086 (US).
- (81) Designated States (unless otherwise indicated, for every kind of national protection available): AE, AG, AL, AM, AO, AT, AU, AZ, BA, BB, BG, BH, BR, BW, BY, BZ, CA, CH, CN, CO, CR, CU, CZ, DE, DK, DM, DO, DZ, EC, EE, EG, ES, FI, GB, GD, GE, GH, GM, GT, HN, HR, HU, ID, IL, IN, IS, JP, KE, KG, KM, KN, KP, KR, KZ, LA, LC, LK, LR, LS, LT, LU, LY, MA, MD, ME, MG, MK, MN, MW, MX, MY, MZ, NA, NG, NI, NO, NZ, OM, PG, PH, PL, PT, RO, RS, RU, SC, SD, SE, SG, SK, SL, SM, SV, SY, TJ, TM, TN, TR, TT, TZ, UA, UG, US, UZ, VC, VN, ZA, ZM, ZW.
- (84) Designated States (unless otherwise indicated, for every kind of regional protection available): ARIPO (BW, GH, GM, KE, LS, MW, MZ, NA, SD, SL, SZ, TZ, UG, ZM, ZW), Eurasian (AM, AZ, BY, KG, KZ, MD, RU, TJ, TM), European (AT, BE, BG, CH, CY, CZ, DE, DK, EE, ES, FI, FR, GB, GR, HR, HU, IE, IS, IT, LT, LU, LV, MC, MT, NL, NO, PL, PT, RO, SE, SI, SK, TR), OAPI (BF, BJ, CF, CG, CI, CM, GA, GN, GQ, GW, ML, MR, NE, SN, TD, TG).
- Published:  
— with international search report

(54) Title: NANO-SKELETAL CATALYST

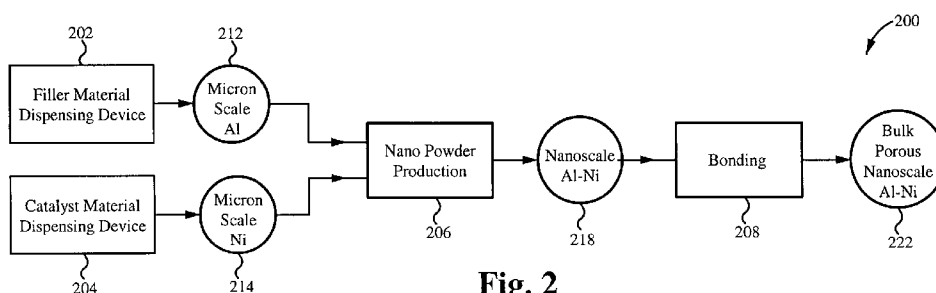

Fig. 2

(57) Abstract: A method of producing a catalyst material with nano-scale structure, the method comprising: introducing a starting powder into a nano-powder production reactor, the starting powder comprising a catalyst material; the nano-powder production reactor nano-sizing the starting powder, thereby producing a nano-powder from the starting powder, the nano-powder comprising a plurality of nano-particles, each nano-particle comprising the catalyst material; and forming a catalyst precursor material from the nano-powder, wherein the catalyst precursor material is a densified bulk porous structure comprising the catalyst material, the catalyst material having a nano-scale structure.

WO 2008/140784 A1

### CROSS-REFERENCE TO RELATED APPLICATIONS

5 The present application claims priority to co-pending U.S. Patent Application Serial No. 11/110,341, filed on April 19, 2005, entitled, "HIGH THROUGHPUT DISCOVERY OF MATERIALS THROUGH VAPOR PHASE SYNTHESIS" and to co-pending U.S. Provisional Application Serial Number 60/928,946, filed May 11, 2007, entitled "MATERIAL PRODUCTION SYSTEM AND METHOD," both of which are hereby incorporated by reference as if set forth herein.

10

### FIELD OF THE INVENTION

The present invention relates to catalysts, primarily metal catalysts used in fixed bed catalysis of fluid flows, and to methods of reusing catalytic materials. More particularly, the present invention relates to methods of producing a catalyst precursor material with nano-scale structure, methods of producing a skeletal catalyst with nano-scale structure from the precursor, and systems capable of performing these methods.

15

### BACKGROUND OF THE INVENTION

Catalysts play many important roles in industry. One such role is fluid conditioning, including decontamination of flowing fluid. For example, a catalytic system might be employed to remove oxygen content from an inert gas flow. The "catalytic converter" employed in automobiles (circa. 2007 and earlier) removes certain pollutants from an exhaust flow produced by the engine. "Solid" catalysts—so-called because the catalytic compound exists in solid phase during use—are often employed in this role, as fluid decontamination typically involves removal of the contaminant from fluid phase, aerosol state, solution, or entrainment.

20

25

"Raney nickel", a solid phase catalyst formed of nickel grains bonded in a skeletal structure along with aluminum grains, performs many industrial roles, including fluid conditioning. A variety of similar catalysts employ other active materials, including iron or copper, instead of nickel, and other alloying components, such as zinc or silicon, instead of aluminum. Currently, all of these "Raney-style" catalysts are formed via processes essentially similar to the original recipe for Raney nickel.

30

A Raney-style process describes a multi-step method of forming a porous, active

metal catalyst. First, a precursor is formed of at least a binary alloy of metals where one of the metals can be extracted. Second, the precursor is activated by extracting an alloy constituent leaving a porous residue comprising a metal that has catalytic activity. Such processes are described in, e.g. Raney, M. *Catalysts from Alloys*, Ind. Eng. Chem., 1940, 32, 1199; as well  
5 as U.S. Pats. No. 1,628,190; 1,915,473; 2,139,602; 2,461,396 and 2,977,327 to M. Raney. Commercial catalysts made by these type of processes are sold by W. R. Grace & Co. under the trademark RANEY® catalyst.

Often, additional materials are added and process parameters are varied to achieve a desired catalytic activity or function. Typically, the process parameters and additional  
10 materials included depend both on the active material employed and the catalytic function desired. Some added materials called “promoters” serve to enhance catalytic activity. A typical process parameter that is varied according to specific needs is the precursor alloy composition. For example, the precursor used for Raney nickel typically consists of equal amounts of nickel and aluminum by volume.

The traditional Raney-style process results in a collection of granular pieces, each  
15 with an internal porosity. Depending on their grain size, these particles are used in slurry or in packed-column systems as heterogeneous catalysts. Generally, larger particle sizes are required for use in packed-column systems. Traditionally, there is a tradeoff between surface area and particle size, with larger-sized particles having less surface area per unit volume.  
20 See, e.g. the background section of U.S. Pat. No. 4,895,994.

Although small powder catalysts have desirable surface area to volume characteristics, they are only suitable for batch processing and must be isolated after use. In order to avoid these disadvantages, a variety of processing regimes have been proposed to permit use of Raney particles in fixed-bed catalysis. For example, U.S. Pat. No. 4,895,994 describes a fixed  
25 bed catalyst shaped from Raney precursor mixed with a polymer, cured, and then activated via a leaching process. U.S. Pat. No. 5,536,694 describes a fixed-bed catalyst prepared from powders of Raney precursor mixed with a powder of its catalytically active component as a binder. However, these processes involve high sintering temperatures and thus cannot accommodate small, high surface-to-volume-ratio precursor particles (the sintering  
30 temperatures are sufficient to destroy the grain structure of the precursor alloy in small particles). Thus, lacking the high surface to volume ratio provided by the smallest precursor sizes, these approaches instead rely on macroporosity of the fixed bed structure to achieve high internal diffusion, making the most of their surface area.

Therefore, the smallest precursor particles suitable for fixed-bed catalyst production via traditional means are micron scale particles. FIG. 1 illustrates such a system process. Micron scale aluminum powder 112 and micron scale nickel powder 114 are combined in a melt-based alloying step 116, thereby producing nickel-aluminum alloy 118 in a variety of alloy phases. The nickel-aluminum alloy 118 is then processed and activated, such as by a leaching apparatus 120, resulting in a bulk porous structure 122 that is mostly nickel (though some aluminum may remain). In some prior art systems, the activation precedes a processing step, whereas in other systems, the activation follows processing to produce a bulk structure. In either case, an aluminum leach step 120 is involved in producing a bulk porous structure 122 composed substantially of nickel. Unfortunately, the smallest pores within the structure produced are micron scale.

What is needed in the art is a system and method for producing a catalyst precursor material and a skeletal catalyst having smaller particle size, and therefore larger surface area available for catalysis.

#### SUMMARY OF THE INVENTION

The embodiments of the present invention include methods of producing a catalyst precursor material with nano-scale structure, methods of producing a skeletal catalyst with nano-scale structure from the precursor, and systems capable of performing these methods.

In one aspect of the present invention, a method of producing a catalyst material with nano-scale structure is disclosed. The method comprises providing a starting powder into a nano-powder production reactor. The starting powder comprises a catalyst material. Next, the nano-powder production reactor nano-sizes the starting powder, thereby producing a nano-powder from the starting powder. The nano-powder comprises a plurality of nano-particles, with each nano-particle comprising the catalyst material. A catalyst precursor material is then formed from the nano-powder. This catalyst precursor material is a densified bulk porous structure comprising the catalyst material, wherein the catalyst material has a nano-scale structure.

In another aspect of the present invention, a method of producing a catalyst material with nano-scale structure from nickel and aluminum is disclosed. The method comprises providing a catalyst powder and a filler powder into a nano-powder production reactor. The catalyst powder comprises nickel, while the filler powder comprises aluminum. Next, a plasma flow is generated within the nano-powder production reactor and applied to the

catalyst powder and the filler powder within the nano-powder production reactor, thereby nano-sizing the catalyst powder and the filler powder. As a result of this nano-sizing, a nano-powder is formed, which is defined by a plurality of nano-particles, wherein each nano-particle comprises nickel and aluminum. A catalyst precursor material is then formed from the nano-powder, wherein the catalyst precursor material is a densified bulk porous structure comprising the plurality of nano-particles.

In yet another aspect of the present invention, a method of producing a catalyst material with nano-scale structure purely from nickel is disclosed. The method comprises providing a catalyst powder into a nano-powder production reactor. The catalyst powder comprises nickel. Next, a plasma flow is generated within the nano-powder production reactor and applied to the catalyst powder within the nano-powder production reactor, thereby nano-sizing the catalyst powder. As a result of this nano-sizing, a nano-powder is formed, which is defined by a plurality of nano-particles, wherein each nano-particle comprises nickel. A catalyst precursor material is then formed from the nano-powder, wherein the catalyst precursor material is a densified bulk porous structure comprising the plurality of nano-particles.

In yet another aspect of the present invention, a system for producing a catalyst material with nano-scale structure is disclosed. The system comprises a powder dispensing device configured to provide a starting powder. The starting powder comprises a catalyst material. The system also comprises a nano-powder production reactor configured to receive the starting powder from the powder dispensing device and produce a nano-powder from the starting powder, wherein the nano-powder comprises a plurality of nano-particles, with each particle comprising the catalyst material. The system further includes a bonding device configured to receive the nano-powder and form a catalyst precursor material from the nano-powder, wherein the catalyst precursor material is a densified bulk porous structure comprising the catalyst material, and the catalyst material has a nano-scale structure.

In the systems and methods of the present invention, the catalyst material is preferably a metal of the transition group VIII of the periodic table of elements. Examples of preferred metals include nickel, iron, and cobalt. In some embodiments, the catalyst material is copper. Additionally, the filler material is preferably aluminum. However, in some embodiments, the filler material can be another material, such as zinc or silicon. Preferably, the starting powder is micron-scale, meaning it has an average grain size of at least 1 micron.

The systems and methods of the present invention involve forming a catalyst precursor material from nano-powder in such a way that leaves the nano-scale structure of the nano-powder substantially intact. In a preferred embodiment, the step of forming includes a step of bonding the nano-powder, possibly preceded by a step of pressing the nano-powder.

5 Preferably, the bonding comprises spark-plasma sintering the nano-powder.

In some embodiments, the present invention can further comprise adding a promoter material to the bulk porous structure during the forming step. Preferably, the promoter material is one of the following: zinc, molybdenum, and chromium.

10 Furthermore, the present invention can include activating the catalyst material in the precursor in order to form a nano-skeletal catalyst. Different activation steps, such as leaching or etching, may be performed depending on the make-up and structure of the precursor. Both the oxide etching apparatus and the leaching apparatus preferably employ supercritical solutions. The oxide etching apparatus preferably employs a supercritical etch solution, while the leaching apparatus preferably employs a supercritical leaching solution. In  
15 certain embodiments where the use of leaching is appropriate, selective leaching with a basic solution is preferably used to remove the substantial portion of the filler material from the bulk structure. Preferably, the filler material left is present in a relatively stable alloy phase (e.g., the alloy phase is more stable than other alloy phases given the set of materials).

20 By forming the bulk structure from nano-sized particles instead of micron-sized (or larger sized) particles, the total catalytic surface area can be significantly increased, given that a nano-particle is significantly smaller than a micron particle thereby allowing for a greater quantity of nano-particles than micron particles. The present invention can increase the total catalytic surface area even more by removing a filler from each particle, thereby creating an internal porosity within each particle, rather than just the bulk porosity between the collection  
25 of particles. This internal porosity results in an internal surface area, and therefore, an increase in total surface area. The nano-skeletal structure produced via the present invention preferably has a surface area of at least 10,000 times the surface area of a micron scale structure of the same volume. The increase in surface area results in massive cost savings.

### 30 BRIEF DESCRIPTION OF THE DRAWINGS

FIG. 1 is a schematic illustration of a prior art system for producing a skeletal catalyst, specifically Raney nickel.

FIG. 2 is a schematic illustration of one embodiment of a system for producing a

nano-scale skeletal precursor in accordance with the principles of the present invention.

FIG. 3 is a schematic illustration of one embodiment of a system for producing a nano-scale skeletal catalyst in accordance with the principles of the present invention.

FIG. 4 is a schematic illustration of another embodiment of a system for producing a nano-scale skeletal catalyst in accordance with the principles of the present invention.

FIG. 5 is a flow chart illustrating one embodiment of a method of producing a nano-scale skeletal precursor and a nano-scale skeletal catalyst in accordance with the principles of the present invention.

FIG. 6 is a flow chart illustrating one embodiment of a method of producing a nano-scale skeletal precursor and a nano-scale skeletal catalyst from a catalyst material and a filler material in accordance with the principles of the present invention.

FIG. 7 is a flow chart illustrating one embodiment of a method of producing a nano-scale skeletal precursor and a nano-scale skeletal catalyst purely from a catalyst material in accordance with the principles of the present invention.

#### DETAILED DESCRIPTION OF THE INVENTION

The description below concerns several embodiments of the invention. The discussion references the illustrated preferred embodiment. However, the scope of the present invention is not limited to either the illustrated embodiment, nor is it limited to those discussed, to the contrary, the scope should be interpreted as broadly as possible based on the language of the Claims section of this document.

This disclosure refers to both particles and powders. These two terms are equivalent, except for the caveat that a singular "powder" refers to a collection of particles. The present invention may apply to a wide variety of powders and particles. Additionally, for the purposes of this disclosure, the terms nano-powders and nano-particles refer to powders and particles having an average grain size less than 250 nanometers and an aspect ratio between one and one million.

The present invention will be readily understood by the following detailed description in conjunction with the accompanying drawings. To facilitate this description, like reference numerals designate like elements.

The embodiments of the present invention revolve around the use of a nano-powder production reactor to produce nano-skeletal catalytic precursors. In general, vapor phase nano-powder production means are preferred. Most preferably, the embodiments of the

present invention use nano-powder production systems similar to those disclosed in U.S. Pat. Application Serial No. 11/110,341, filed on April 19, 2005 and entitled, "HIGH THROUGHPUT DISCOVERY OF MATERIALS THROUGH VAPOR PHASE SYNTHESIS", which is currently published as U.S. Publication No. 2005-0233380-A. In  
5 such a nano-powder production system, working gas is supplied from a gas source to a plasma reactor. Within the plasma reactor, energy is delivered to the working gas, thereby creating a plasma. A variety of different means can be employed to deliver this energy, including, but not limited to, DC coupling, capacitive coupling, inductive coupling, and resonant coupling. One or more material dispensing devices introduce at least one material,  
10 preferably in powder form, into the plasma reactor. The combination within the plasma reactor of the plasma and the material(s) introduced by the material dispensing device(s) forms a highly reactive and energetic mixture, wherein the powder can be vaporized. This mixture of vaporized powder moves through the plasma reactor in the flow direction of the working gas. As it moves, the mixture cools and particles are formed therein. The still-  
15 energetic output mixture, comprising hot gas and energetic particles, is emitted from the plasma reactor. Following emission from the plasma reactor, the output mixture cools further and is exposed to a sampling device, which selectively samples portions of the output mixture, which comprises hot gas and particles of relatively homogeneous size distribution. Each particle can comprise a combination of the materials introduced by the material  
20 dispensing devices. The sampling device can be used to collect particles for further use or processing. It is contemplated that the sampling device can be incorporated into the reactor so that the reactor not only nano-sizes the powder, but samples and collects the nano-particles as well. In this respect, when discussing the nano-sizing and bonding steps below, it is implied that the nano-sizing step can include such particle sampling and collection necessary  
25 for providing the particles in sufficient form for the bonding step.

It is contemplated that other nano-powder production means, including non-vapor phase nano-powder production means, are within the scope of the present invention. Additionally, other configurations of sampling devices and collection devices are contemplated as being within the scope of the present invention as well.

30 Furthermore, the preferred embodiments of the present invention employ non-traditional sintering techniques to bond nano-scale materials in order to facilitate the preservation of the materials' nano-scale structure. Preferably, embodiments of the present invention employ fast sintering techniques to avoid agglomeration and loss of nano-structure.



Exemplary fast sintering techniques are the sintering techniques known as spark-plasma sintering (SPS), field assisted sintering technique (FAST) or pulsed electric current sintering (PECS).

When used with conductive samples, such as in the present invention, these fast sintering techniques pulse DC current through the sample being sintered, causing resistive internal heating of the sample. Because the resistive load is relatively uniform throughout the sample, heat is generated uniformly throughout the sample. Furthermore, heat generation is initiated relatively simultaneously throughout a conductive sample, as it occurs with the electron movement. Since electron diffusion at the voltages involved is much faster than thermal diffusion, heating rates are potentially much faster than with conventional sintering. The fast heating and cooling provided by these techniques facilitates preservation of the sample's nano-scale structure.

Furthermore, embodiments of the present invention produce nano-scale bulk porosity, involving scales at which conventional liquid leaching chemistries can become less effective. Some embodiments contemplate using alternative leaching systems to remove filler materials. For example, supercritical fluid solutions are capable of wetting very small features. Thus, supercritical phase leaching chemistries are employed in some embodiments of the present invention.

FIG. 2 illustrates an embodiment of the present invention that is a system 200 for producing a catalyst precursor material with nano-scale structure. The system 200 includes a catalyst material dispensing device 204, a filler material dispensing device 202, a nano-powder production reactor 206, and a bonding device 208.

The catalyst material dispensing device 204 is configured to provide micron scale catalyst material 214. Preferably, the catalyst material of the present invention is a metal of the transition group VIII of the periodic table of elements. Examples of preferred metals include nickel, iron, and cobalt. In certain embodiments, copper can also be used as a catalyst material.

The filler material dispensing device 202 is configured to provide micron scale filler material 212. Preferably, the filler material of the present invention is aluminum. However, in some embodiments, the filler material can also be zinc or silicon.

In a preferred embodiment, the catalyst material dispensing device 204 and the filler material dispensing device 202 are fluidly coupled to a nano-powder production reactor 206.

The nano-powder production reactor is configured to receive the catalyst material 214 and the filler material 212 and to produce a nano-powder 218 defined by a plurality of nano-particles, each particle comprising filler material and catalyst material, e.g. aluminum and nickel. This nano-sizing may be achieved in a variety of ways. However, in a preferred embodiment, the reactor employs the application of plasma to the powder as discussed above.

The bonding device 208 is configured to receive the nano-powder 218 and to form a densified bulk porous structure 222 from at least the nano-powder 218, employing means that leaves the nano-scale structure of the nano-powder substantially intact. Preferably, such means includes spark-plasma sintering. The bonding device 208 can be fluidly coupled to the nano-powder production reactor 206 in order to receive the nano-powder 218 from the reactor 206. Alternatively, the bonding device 208 can be separated from the reactor 206.

FIG. 3 illustrates an embodiment of the present invention that is a system 300 for producing a skeletal catalyst with nano-scale structure. The system 300 includes a portion similar to the system of FIG. 2 for producing a precursor with nano-scale structure. The system 300 includes a catalyst material dispensing device 204, a filler material dispensing device 202, a nano-powder production reactor 206, a bonding device 208, and a filler leaching apparatus 310.

Similar to FIG. 2, the catalyst material dispensing device 204 is configured to provide micron scale catalyst material 214, such as nickel. The filler material dispensing device 202 is configured to provide micron scale filler material 212, such as aluminum. In a preferred embodiment, the catalyst material dispensing device 204 and the filler material dispensing device 202 are fluidly coupled to a nano-powder production reactor 206.

The nano-powder production reactor is configured to receive the catalyst material 214 and the filler material 212 and to produce a nano-powder 218 defined by a plurality of nano-particles, each particle comprising filler material and catalyst material, e.g. aluminum and nickel. This nano-sizing may be achieved in a variety of ways. However, in a preferred embodiment, the reactor employs the application of plasma to the powder as discussed above.

The bonding device 208 is configured to receive the nano-powder 218 and to form a densified bulk porous structure 222 from at least the nano-powder 218, employing means that leaves the nano-scale structure of the nano-powder substantially intact. Preferably, such means includes spark-plasma sintering. The bonding device 208 can be fluidly coupled to the nano-powder production reactor 206 in order to receive the nano-powder 218 from the reactor

206. Alternatively, the bonding device 208 can be separated from the reactor 206.

The filler leaching apparatus 310 is configured to receive the bulk porous structure 222, preferably from the bonding device 208, and to remove a substantial portion of the filler material from the densified bulk porous structure 222 to form a nano-scale skeletal structure, thereby activating the material to form a nano-skeletal catalyst 324. Here, the filler leaching apparatus 310 removes substantially all of the filler material, leaving the nano-skeletal catalyst 324 to consist primarily of bulk porous nano-scale catalyst material. Although a very small amount of the filler material may remain, enough is removed to expose and activate pores in the catalyst material. In a preferred embodiment, selective leaching with a basic solution is used to remove the substantial proportion of the filler material from the bulk structure. Preferably, any remaining filler material is present in a relatively stable alloy phase (e.g., the alloy phase is more stable than other alloy phases given the set of materials).

FIG. 4 illustrates an embodiment of the present invention that is a system 400 for producing a skeletal catalyst with nano-scale structure that does not require a filler material. The system 400 includes a catalyst material dispensing device 204, a nano-powder production reactor 206, a bonding device 208, and an oxide etching apparatus 410. In a preferred embodiment, system 400 operates under inert conditions.

Similar to FIGS. 2-3, the catalyst material dispensing device 204 is configured to provide micron scale catalyst material 214, such as nickel. In a preferred embodiment, the catalyst material dispensing device 204 is fluidly coupled to the nano-powder production reactor 206. This embodiment is characterized by an absence of filler material. Therefore, the only powder being provided to system 400 and reactor 206 is catalyst material.

The nano-powder production reactor 206 is configured to receive the catalyst material 214 and to produce a nano-powder 418 defined by a plurality of nano-particles, each particle comprising catalyst material, e.g. nickel. This nano-sizing may be achieved in a variety of ways. However, in a preferred embodiment, the reactor employs the application of plasma to the powder as discussed above.

The bonding device 208 is configured to receive the nano-powder 418 and to form a densified bulk porous structure 422 from the nano-powder 418, employing means that leaves the nano-scale structure of the nano-powder substantially intact. Preferably, such means includes spark-plasma sintering. The bonding device 208 can be fluidly coupled to the nano-powder production reactor 206 in order to receive the nano-powder 418 from the reactor 206.

Alternatively, the bonding device 208 can be separated from the reactor 206.

Typically, the bonding process introduces some surface oxidation or other contamination into the bulk porous structure 422. Thus, the bonding step produces a contaminated bulk structure. Typically, this contamination is oxide. Here, the bulk porous structure 422 includes oxidized catalyst material, which in the present example is oxidized nickel. The oxide etching apparatus 410 is configured to receive the bulk porous structure 422, preferably from the bonding device 208, and to remove substantially all of the contamination from the densified bulk porous structure 422 in order to form a nano-scale skeletal structure, thereby activating the material to form a nano-skeletal catalyst 424. In the present example, the oxide leaching apparatus 410 removes substantially all of the oxide, leaving the nano-skeletal catalyst 424 to consist primarily of bulk porous nano-scale catalyst material. Although a very small amount of the contamination may remain, enough is removed to expose and activate the catalyst material.

FIGS. 2-4 illustrate systems capable of practicing embodiments of the present invention. These systems are configured to perform methods for producing nano-scale skeletal precursors and nano-scale skeletal catalysts.

FIG. 5 is a flow chart illustrating one embodiment of a method 500 of producing a nano-scale skeletal precursor and a nano-scale skeletal catalyst in accordance with the principles of the present invention.

At step 502, a starting powder is introduced into the nano-powder production reactor. This starting powder may contain both catalyst material and filler material, or only catalyst material.

At step 504, the reactor nano-sizes the starting powder, thereby producing a plurality of nano-particles, with each particle containing catalyst material. This nano-sizing may be achieved in a variety of ways. However, in a preferred embodiment, the reactor employs the application of plasma to the powder as discussed above.

At step 506, a densified bulk porous precursor is formed from the nano-particles. This densified precursor contains nano-scale catalyst material. The step of forming can include a step of pressing the nano-powder, followed by a step of bonding the nano-powder. However, it is contemplated that the densified bulk porous precursor may be formed in a variety of ways so long as the means that are employed leave the nano-scale structure of the nano-powder substantially intact. Preferably, such means comprises spark-plasma sintering.

If all that is desired is to form a densified bulk porous precursor, then the method 500 may come to an end. However, the method may optionally continue at step 508, where the catalyst material in the precursor is activated, thereby forming a nano-skeletal catalyst. Different activation steps, such as leaching or etching, may be performed depending on the  
5 make-up and structure of the precursor.

FIG. 6 is a flow chart illustrating one embodiment of a method 600 of producing a nano-scale skeletal precursor and a nano-scale skeletal catalyst from a catalyst material and a filler material in accordance with the principles of the present invention.

At step 602, a starting powder is introduced into the nano-powder production reactor.  
10 This starting powder contains both catalyst material and filler material.

At step 604, the reactor applies a plasma flow to the starting powder, as discussed above, in order to nano-size the starting powder, thereby producing a plurality of nano-particles, with each particle containing catalyst material and filler material.

At step 606, a densified bulk porous precursor is formed from the nano-particles.  
15 This densified precursor contains nano-particles comprising the catalyst material and the filler material. The step of forming can include a step of pressing the nano-powder, followed by a step of bonding the nano-powder. However, it is contemplated that the densified bulk porous precursor may be formed in a variety of ways so long as the means that are employed leave the nano-scale structure of the nano-powder substantially intact. Preferably, such means  
20 comprises spark-plasma sintering.

If all that is desired is to form a densified bulk porous precursor, then the method 600 may come to an end. However, the method may optionally continue at step 608, where the catalyst material in the precursor is activated by removing substantially all of the filler material from the precursor, thereby forming a nano-skeletal catalyst. Different removal steps  
25 may be performed depending on the make-up and structure of the precursor. However, in a preferred embodiment, a leaching process is employed.

FIG. 7 is a flow chart illustrating one embodiment of a method 700 of producing a nano-scale skeletal precursor and a nano-scale skeletal catalyst purely from a catalyst material and without a filler material in accordance with the principles of the present invention.

30 At step 702, a starting powder is introduced into the nano-powder production reactor.

This starting powder contains catalyst material and is characterized by the absence of filler material.

At step 704, the reactor applies a plasma flow to the starting powder, as discussed above, in order to nano-size the starting powder, thereby producing a plurality of nano-  
5 particles, with each particle containing catalyst material.

At step 706, a densified bulk porous precursor is formed from the nano-particles. This densified precursor contains nano-particles comprising the catalyst material. The step of forming can include a step of pressing the nano-powder, followed by a step of bonding the nano-powder. However, it is contemplated that the densified bulk porous precursor may be  
10 formed in a variety of ways so long as the means that are employed leave the nano-scale structure of the nano-powder substantially intact. Preferably, such means comprises spark-plasma sintering.

If all that is desired is to form a densified bulk porous precursor, then the method 700 may come to an end. However, the method may optionally continue at step 708, where the  
15 catalyst material in the precursor is activated by removing a substantial portion of any surface contamination from the precursor, thereby forming a nano-skeletal catalyst. Different removal steps may be performed depending on the make-up and structure of the precursor. However, in a preferred embodiment, an etching process is employed.

In some embodiments, the methods of the present invention can further comprise  
20 adding a promoter material to the bulk porous structure during the forming step. Preferably, the promoter material is one of the following: zinc, molybdenum, and chromium.

The embodiments of the present invention include methods of producing a catalyst precursor material with nano-scale structure, methods of producing a skeletal catalyst with nano-scale structure from the precursor, and systems capable of performing these methods.  
25 By forming the bulk structure from nano-sized particles instead of micron-sized (or larger sized) particles, the total catalytic surface area can be significantly increased, given that a nano-particle is significantly smaller than a micron particle thereby allowing for a greater quantity of nano-particles than micron particles. The present invention can increase the total catalytic surface area even more by removing a filler from each particle, thereby creating an  
30 internal porosity within each particle, rather than just the bulk porosity between the collection of particles. This internal porosity results in an internal surface area, and therefore, an increase in total surface area. The nano-skeletal structure produced via the present invention

preferably has an effective BET surface area of at least 10,000 times the surface area of a micron scale structure of the same volume. The increase in surface area results in massive cost savings.

The present invention has been described in terms of specific embodiments  
5 incorporating details to facilitate the understanding of the principles of construction and  
operation of the invention. As such, references herein to specific embodiments and details  
thereof are not intended to limit the scope of the claims appended hereto. It will be apparent  
to those skilled in the art that modifications can be made to the embodiments chosen for  
illustration without departing from the spirit and scope of the invention.

10

15

CLAIMS

What is claimed is:

- 5 1. A method of producing a catalyst material with nano-scale structure, the method comprising:
- providing a starting powder into a nano-powder production reactor, the starting powder comprising a catalyst material;
- 10 the nano-powder production reactor nano-sizing the starting powder, thereby producing a nano-powder from the starting powder, the nano-powder comprising a plurality of nano-particles, each nano-particle comprising the catalyst material; and
- forming a catalyst precursor material from the nano-powder, wherein the catalyst precursor material is a densified bulk porous structure comprising the catalyst material, the catalyst material having a nano-scale structure.
- 15
2. The method of Claim 1, wherein:
- the starting powder further comprises a filler material;
- each of the nano-particles further comprises the filler material; and
- 20 the bulk porous structure of the catalyst precursor material further comprises the filler material.
3. The method of Claim 2, wherein the step of nano-sizing the starting powder includes:
- generating a plasma flow within the nano-powder production reactor; and
- applying the plasma flow to the starting powder.
- 25
4. The method of Claim 2, wherein the step of forming a catalyst precursor material includes pressing the nano-powder.



5. The method of Claim 2, wherein the step of forming a catalyst precursor material includes bonding the nano-powder using spark plasma sintering, thereby preserving the nano-scale structure of the catalyst material.
- 5 6. The method of Claim 2, wherein the starting powder has an average grain size greater than or equal to 1 micron.
7. The method of Claim 2, wherein the catalyst material is a metal of the transition group VIII of the periodic table of elements.
- 10 8. The method of Claim 7, wherein the metal is nickel.
9. The method of Claim 7, wherein the metal is iron.
- 15 10. The method of Claim 7, wherein the metal is cobalt.
11. The method of Claim 2, wherein the filler material is aluminum.
12. The method of Claim 2, wherein the filler material is zinc.
- 20 13. The method of Claim 2, wherein the filler material is silicon.
14. The method of Claim 2, further comprising removing a substantial portion of the filler material from the bulk structure of the catalyst precursor material, thereby forming a nano-scale skeletal structure comprising the catalyst material, wherein the catalyst material is activated to form a nano-skeletal catalyst.
- 25

15. The method of Claim 14, wherein the step of removing the filler material is performed by using a leaching solution.

5 16. The method of Claim 2, wherein the step of forming the catalyst precursor material includes adding a promoter material to the bulk porous structure, the promoter material comprising at least one of zinc, molybdenum and chromium.

17. The method of Claim 1, wherein the starting powder consists only of the catalyst material.

10

18. The method of Claim 17, wherein the step of nano-sizing the starting powder includes:

generating a plasma flow within the nano-powder production reactor; and  
applying the plasma flow to the starting powder.

15

19. The method of Claim 17, wherein the step of forming a catalyst precursor material includes pressing the nano-powder.

20

20. The method of Claim 17, wherein the step of forming a catalyst precursor material includes bonding the nano-powder using spark plasma sintering, thereby preserving the nano-scale structure of the catalyst material.

21. The method of Claim 17, wherein the starting powder has an average grain size greater than or equal to 1 micron.

25

22. The method of Claim 17, wherein the catalyst material is a metal of the transition group VIII of the periodic table of elements.

23. The method of Claim 22, wherein the metal is nickel.

24. The method of Claim 22, wherein the metal is iron.
25. The method of Claim 22, wherein the metal is cobalt.
- 5 26. The method of Claim 17, wherein surface contamination of the nano-powder occurs during the step of forming the catalyst precursor material, thereby producing a contaminated bulk structure, and the method further comprises:
- removing the surface contamination from the contaminated bulk structure, thereby forming a nano-scale skeletal structure comprising the catalyst material,
- 10 wherein the catalyst material is activated to form a nano-skeletal catalyst.
27. The method of Claim 26, wherein the step of removing the surface contamination is performed by using an etching solution.
- 15 28. The method of Claim 17, wherein the step of forming the catalyst precursor material includes adding a promoter material to the bulk porous structure, the promoter material comprising at least one of zinc, molybdenum and chromium.
- 20 29. A method of producing a catalyst material with nano-scale structure from nickel and aluminum, the method comprising:
- providing a catalyst powder into a nano-powder production reactor, the catalyst powder comprising nickel;
- providing a filler powder into the nano-powder production reactor, the filler powder comprising aluminum;
- 25 generating a plasma flow within the nano-powder production reactor;
- applying the plasma flow to the catalyst powder and the filler powder within the nano-powder production reactor, wherein the catalyst powder and the filler powder is nano-sized, thereby forming a nano-powder defined by a plurality of nano-particles, each nano-particle comprising nickel and aluminum; and

forming a catalyst precursor material from the nano-powder, wherein the catalyst precursor material is a densified bulk porous structure comprising the plurality of nano-particles.

- 5 30. The method of Claim 29, wherein the step of forming a catalyst precursor material includes bonding the nano-powder using spark plasma sintering, thereby preserving the nano-scale structure of the nano-particles.
- 10 31. The method of Claim 30, further comprising removing a substantial portion of the aluminum from the bulk structure of the catalyst precursor material, thereby forming a nano-scale skeletal structure comprising the nickel, wherein the nickel is activated to form a nano-skeletal catalyst.
- 15 32. A method of producing a catalyst material with nano-scale structure purely from nickel, the method comprising:
- providing a catalyst powder into a nano-powder production reactor, the catalyst powder comprising nickel;
  - generating a plasma flow within the nano-powder production reactor;
  - 20 applying the plasma flow to the catalyst powder within the nano-powder production reactor, wherein the catalyst powder is nano-sized, thereby forming a nano-powder defined by a plurality of nano-particles, each nano-particle comprising nickel; and
  - forming a catalyst precursor material from the nano-powder, wherein the catalyst precursor material is a densified bulk porous structure comprising the plurality of nano-particles.
- 25 33. The method of Claim 32, wherein the step of forming a catalyst precursor material includes bonding the nano-powder using spark plasma sintering, thereby preserving the nano-scale structure of the nano-particles.

30

34. The method of Claim 33, wherein surface contamination of the nano-powder occurs during the step of forming the catalyst precursor material, thereby producing a contaminated bulk structure, and the method further comprises:

5 removing the surface contamination from the contaminated bulk structure, thereby forming a nano-scale skeletal structure comprising the nickel, wherein the nickel is activated to form a nano-skeletal catalyst.

35. A system for producing a catalyst material with nano-scale structure, the system comprising:

10 a powder dispensing device configured to provide a starting powder, the starting powder comprising a catalyst material;

15 a nano-powder production reactor configured to receive the starting powder from the powder dispensing device and produce a nano-powder from the starting powder, the nano-powder comprising a plurality of nano-particles each comprising the catalyst material; and

20 a bonding device configured to receive the nano-powder and form a catalyst precursor material from the nano-powder, wherein the catalyst precursor material is a densified bulk porous structure comprising the catalyst material, the catalyst material having a nano-scale structure.

36. The system of Claim 35, wherein the nano-powder production reactor is configured to produce the nano-powder by:

25 generating a plasma flow within the nano-powder production reactor; and applying the plasma flow to the starting powder.

37. The system of Claim 35, wherein the bonding device is configured to bond the nano-powder using spark plasma sintering, wherein the spark plasma sintering preserves the nano-scale structure of the catalyst material.

38. The system of Claim 35, wherein:

the starting powder, the nano-particles from the nano-powder production reactor, and the bulk porous structure of the catalyst precursor material each further comprises a filler material; and

5 the system further comprises a leaching apparatus configured to remove a substantial portion of the filler material from the bulk structure of the catalyst precursor material, thereby forming a nano-scale skeletal structure comprising the catalyst material, wherein the catalyst material is activated to form a nano-skeletal catalyst.

10

39. The system of Claim 35, wherein:

the nano-scale catalyst material of the bulk structure has surface contamination; and

15 the system further comprises an etching apparatus configured to remove the surface contamination from the nano-scale catalyst material, thereby forming a nano-scale skeletal structure comprising the catalyst material, wherein the catalyst material is activated to form a nano-skeletal catalyst.

20

25

**Fig. 1**  
**(Prior Art)**

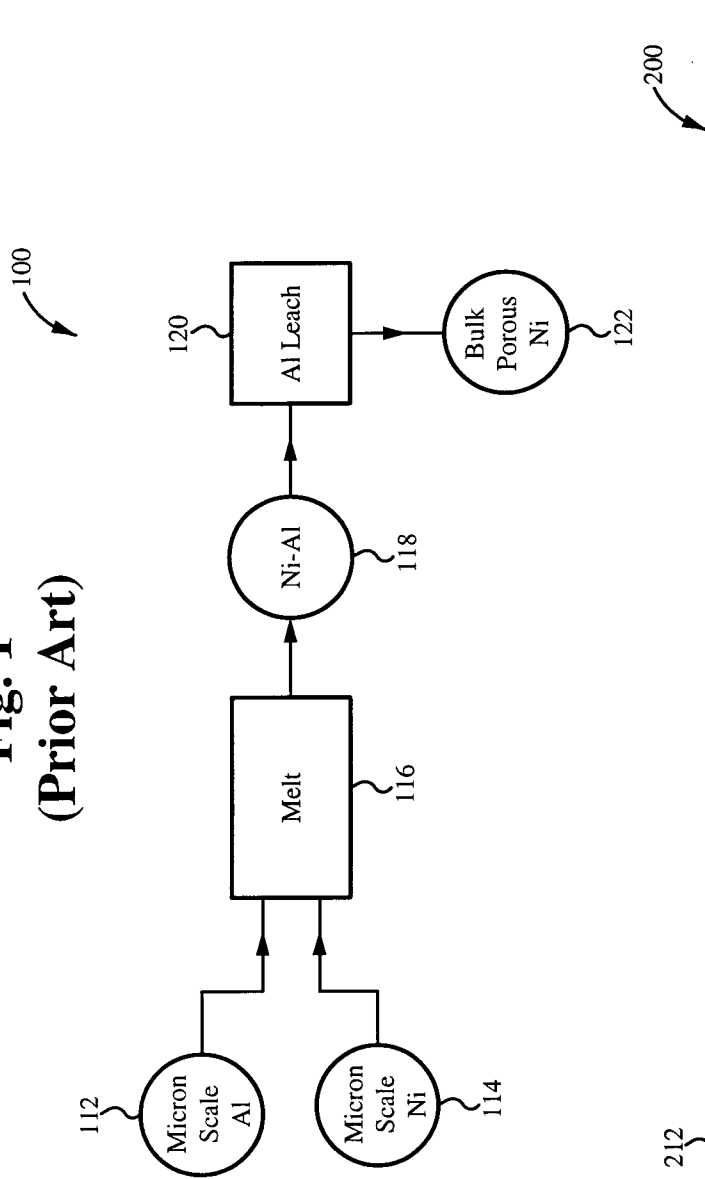

**Fig. 2**

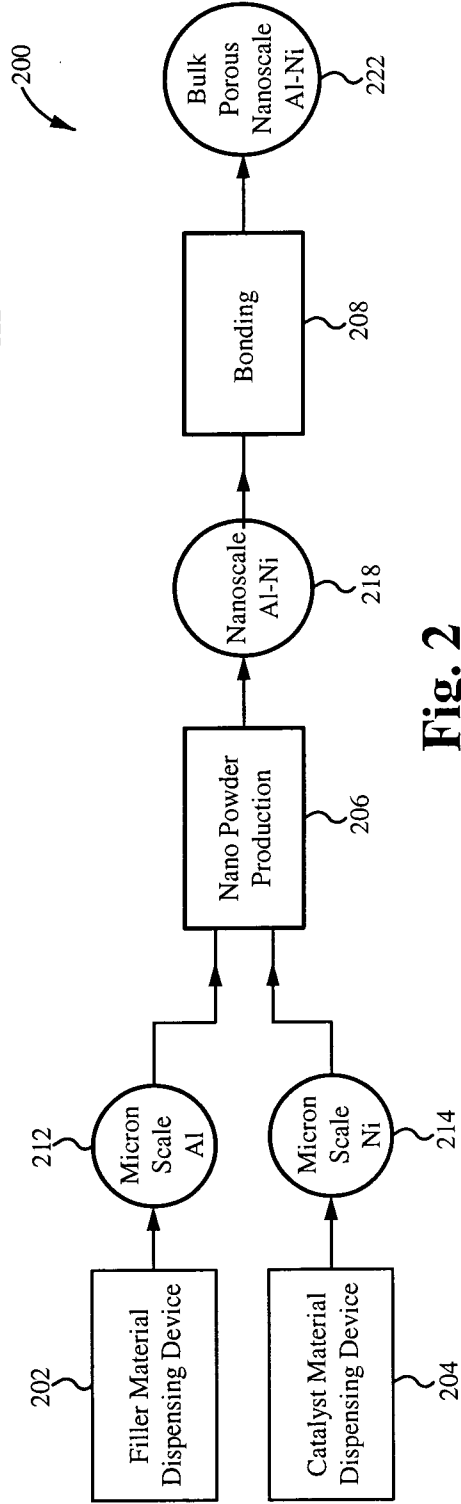

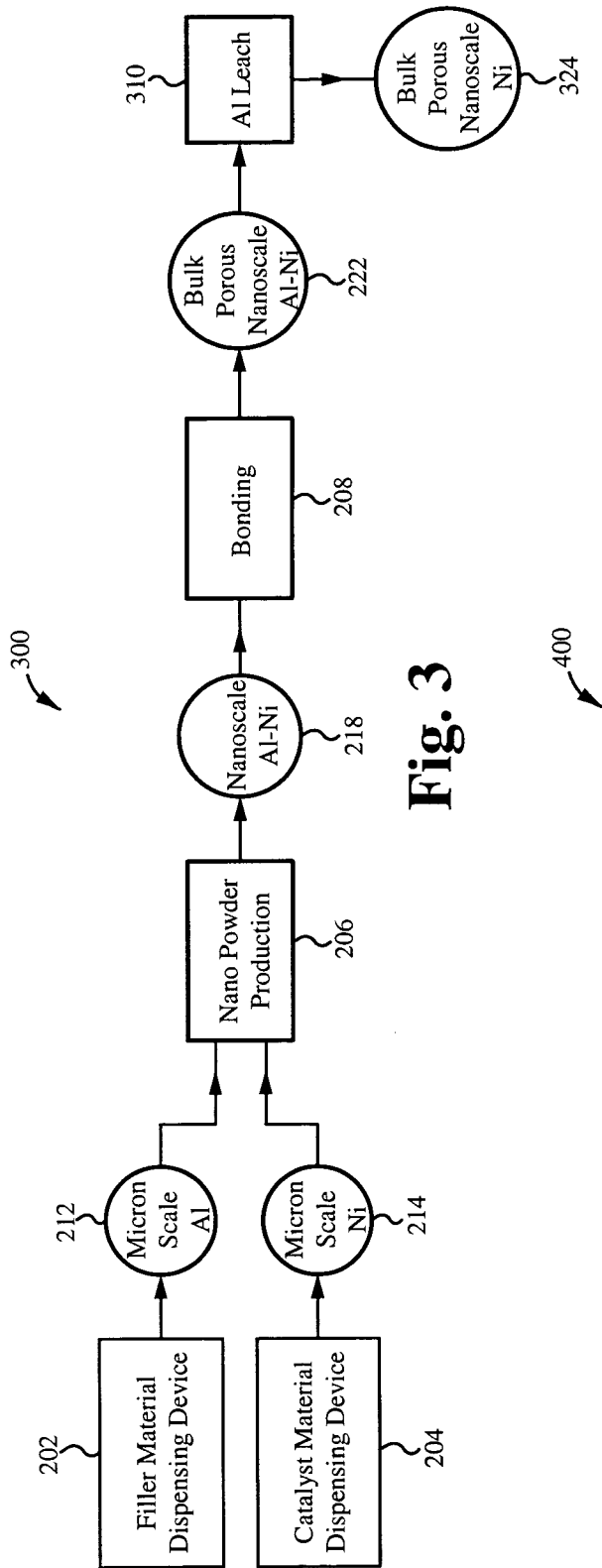

Fig. 3

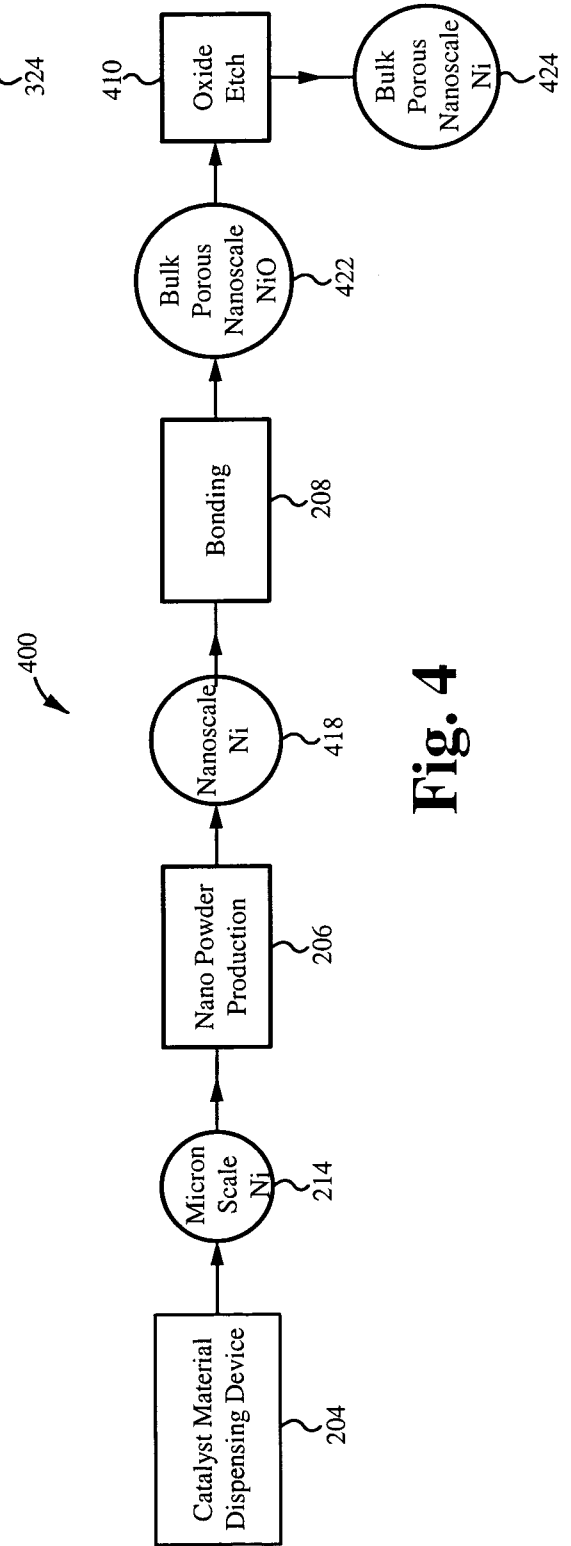
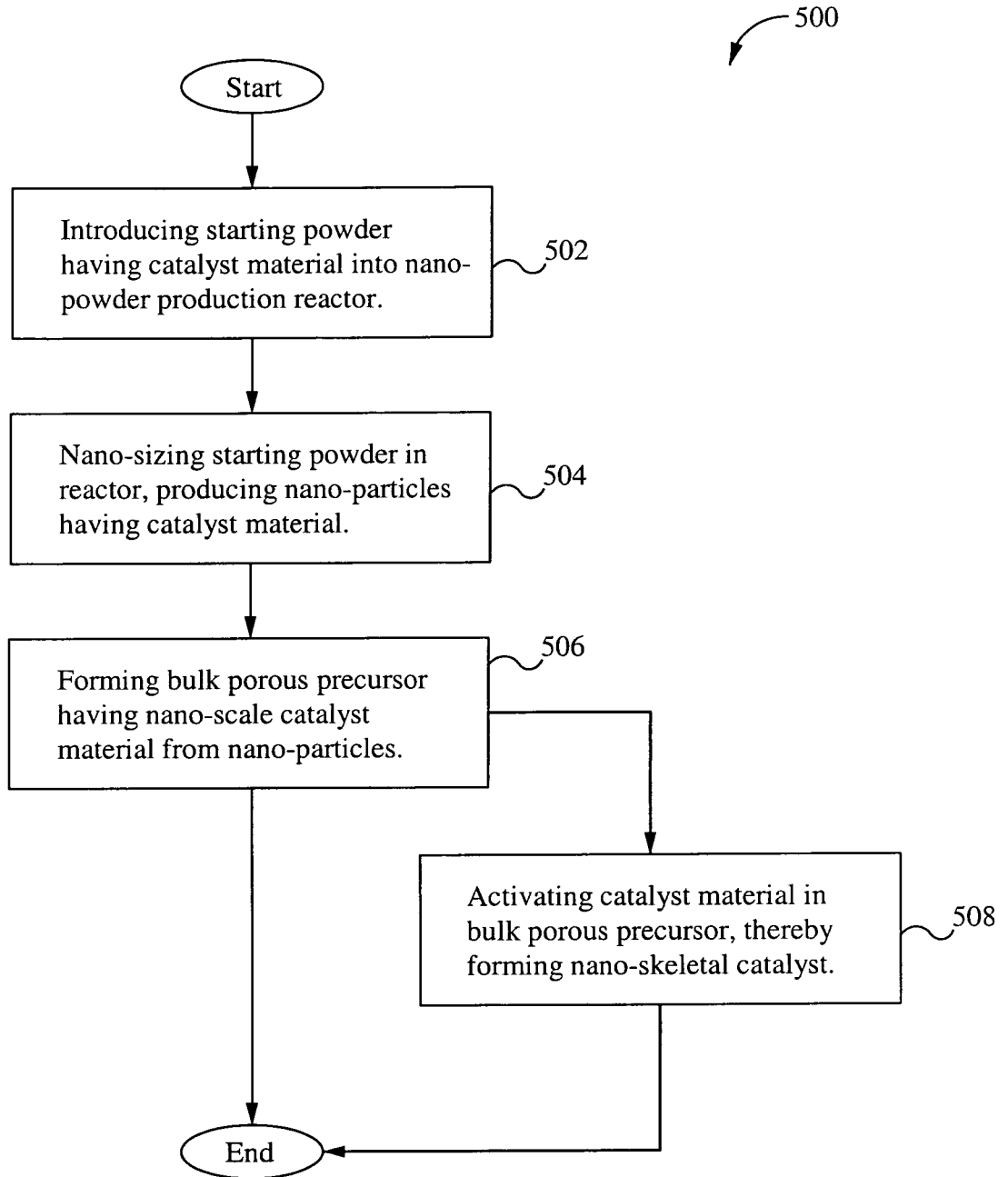
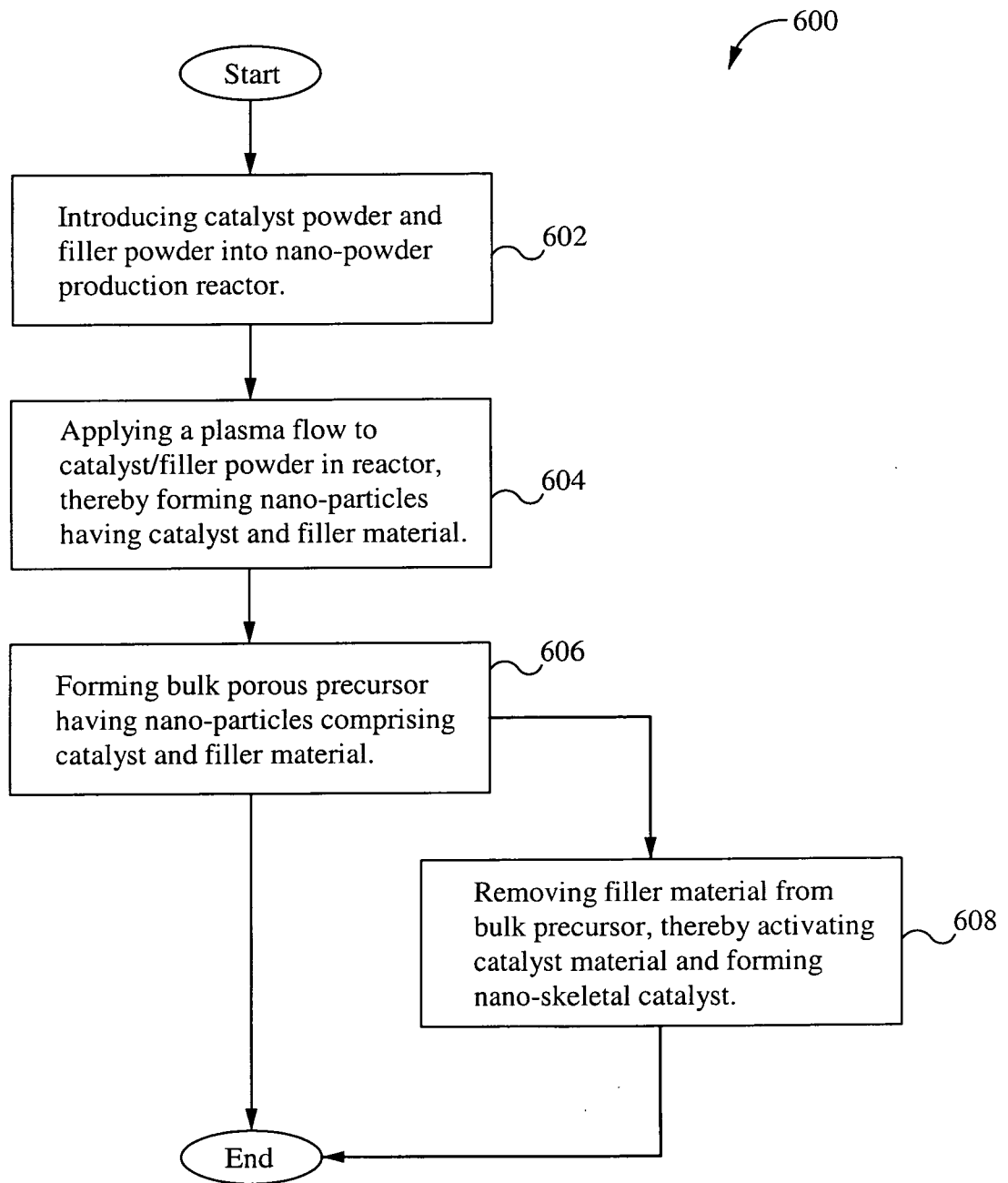

Fig. 4

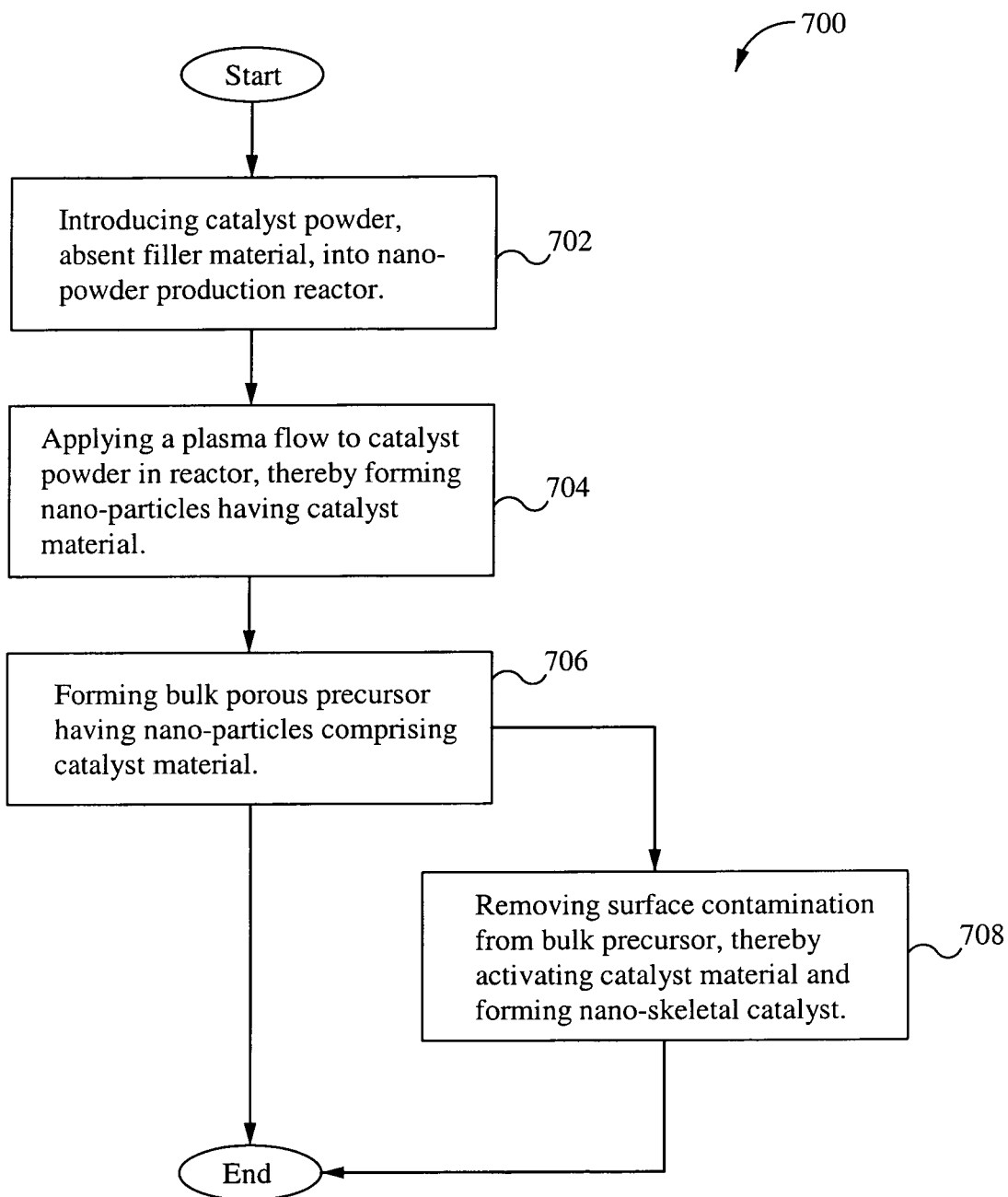



**Fig. 5**



**Fig. 6**



**Fig. 7**

## INTERNATIONAL SEARCH REPORT

International application No.

PCT/US 08/06001

<b>A. CLASSIFICATION OF SUBJECT MATTER</b> IPC(8) - B01J 25/00 (2008.04) USPC - 502/301 According to International Patent Classification (IPC) or to both national classification and IPC		
<b>B. FIELDS SEARCHED</b> Minimum documentation searched (classification system followed by classification symbols) IPC(8): B01J 25/00 (2008.04) USPC: 502/301 Documentation searched other than minimum documentation to the extent that such documents are included in the fields searched USPC: 502/307,\$ (Keywords limited - See Isi for keywords) Electronic data base consulted during the international search (name of data base and, where practicable, search terms used) PubWEST(USPT,PGPB,EPAB,JPAB); DialogPRO(Chemistry); Google Scholar Search Terms: Nano, powder, production, reactor, catalyst\$, structure\$, scale\$, filler\$, porous, particle\$, plasma, flow, grain\$, size\$, transition, skeletal, leaching, promoter, sintering, spark, etching, pressing		
<b>C. DOCUMENTS CONSIDERED TO BE RELEVANT</b>		
Category*	Citation of document, with indication, where appropriate, of the relevant passages	Relevant to claim No.
Y	US 2005/0240069 A1 (Polverejen et al.) 27 October 2005 (27.10.2005), especially, para [0020], [0024] and [0027].	1-39
Y	US 2007/0087934 A1 (R.M. Martens et al.) 19 April 2007 (19.04.2007), especially, para [0015] and [0017].	1-39
Y	US 2005/0097988 A1 (Kodas et al.) 12 May 2005 (12.05.2005), especially, para [0022], [0116], [0218], [0221], [0232], [0249] and [0255].	2-16, 18, 21, 28-34, 36, 38
Y	US 2004/0167009 A1 (Kuntz et al.) 26 August 2004 (26.08.2004), especially, para [0010] and [0027].	5, 19, 20, 30, 31, 33, 34, 37
Y	US 2005/0258766 A1 (Kim) 24 November 2005 (24.11.2005), especially, para [0011] and [0021].	35-39
Y	US 2005/0000321 A1 (O'Leary et al.) 6 January 2005 (06.01.2005), especially, para [0007], [0030] and [0033].	14, 26, 27, 31, 34, 38, 39
<input type="checkbox"/> Further documents are listed in the continuation of Box C. <input type="checkbox"/>		
* Special categories of cited documents: "A" document defining the general state of the art which is not considered to be of particular relevance "E" earlier application or patent but published on or after the international filing date "L" document which may throw doubts on priority claim(s) or which is cited to establish the publication date of another citation or other special reason (as specified) "O" document referring to an oral disclosure, use, exhibition or other means "P" document published prior to the international filing date but later than the priority date claimed "T" later document published after the international filing date or priority date and not in conflict with the application but cited to understand the principle or theory underlying the invention "X" document of particular relevance; the claimed invention cannot be considered novel or cannot be considered to involve an inventive step when the document is taken alone "Y" document of particular relevance; the claimed invention cannot be considered to involve an inventive step when the document is combined with one or more other such documents, such combination being obvious to a person skilled in the art "&" document member of the same patent family		
Date of the actual completion of the international search 29 July 2008 (29.07.2008)		Date of mailing of the international search report 04 AUG 2008
Name and mailing address of the ISA/US Mail Stop PCT, Attn: ISA/US, Commissioner for Patents P.O. Box 1450, Alexandria, Virginia 22313-1450 Facsimile No. 571-273-3201		Authorized officer: Lee W. Young PCT Helpdesk: 571-272-4300 PCT OSP: 571-272-7774