



US00D667550S

(12) **United States Design Patent**
Keckstein

(10) **Patent No.:** **US D667,550 S**

(45) **Date of Patent:** **** Sep. 18, 2012**

(54) **UTERINE MANIPULATOR**

(75) Inventor: **Joerg Keckstein**, Villach (AT)

(73) Assignee: **Karl Storz GmbH & Co. KG** (DE)

(**) Term: **14 Years**

(21) Appl. No.: **29/394,895**

(22) Filed: **Jun. 22, 2011**

(30) **Foreign Application Priority Data**

Dec. 23, 2010 (EM) 001798331-0009

(51) **LOC (9) Cl.** **24-02**

(52) **U.S. Cl.** **D24/141; D24/147**

(58) **Field of Classification Search** D24/133,
D24/141, 143-147; 606/1, 108, 112, 167,
606/119, 193

See application file for complete search history.

(56) **References Cited**

U.S. PATENT DOCUMENTS

5,382,252	A *	1/1995	Failla et al.	606/119
5,409,496	A *	4/1995	Rowden et al.	606/119
5,487,377	A *	1/1996	Smith et al.	606/119
5,520,698	A *	5/1996	Koh	606/119
5,540,700	A *	7/1996	Rowden et al.	606/119
5,643,285	A *	7/1997	Rowden et al.	606/119
D421,497	S *	3/2000	Wattiez	D24/141
D536,446	S *	2/2007	Doll et al.	D24/133
D628,694	S *	12/2010	Donnez	D24/141
2001/0021854	A1 *	9/2001	Donnez et al.	606/119

2009/0131954	A1 *	5/2009	Christian et al.	606/119
2010/0280524	A1 *	11/2010	Lopez Zepeda	606/119
2010/0305578	A1 *	12/2010	Auerbach et al.	606/119

OTHER PUBLICATIONS

Clinical Innovations—Clearview Uterine Manipulator® Brochure; 2001; www.clinicalinnovations.com; 2 pages.
Storz—Karl Storz Endoskope Catalog; Schiff, et al.; Uterus Manipulator; 1996; pp. GYN ACC 6A-GYN ACC 7A.

* cited by examiner

Primary Examiner — Wan Laymon

(74) *Attorney, Agent, or Firm* — St. Onge Steward Johnston & Reens LLC

(57) **CLAIM**

The ornamental design for a uterine manipulator, as shown and described.

DESCRIPTION

FIG. 1 is a bottom left side perspective view of a uterine manipulator in accordance with the new design; FIG. 2 is a left side isometric view thereof; FIG. 3 is a right side isometric view thereof; FIG. 4 is a top isometric view thereof; FIG. 5 is a bottom isometric view thereof; FIG. 6 is an enlarged front isometric view thereof; and, FIG. 7 is an enlarged rear isometric view thereof. The broken lines shown in FIGS. 1, 2, 5 and 7 represent bounds of the design, with the lines themselves and the areas within them forming no part of the claimed design.

1 Claim, 7 Drawing Sheets

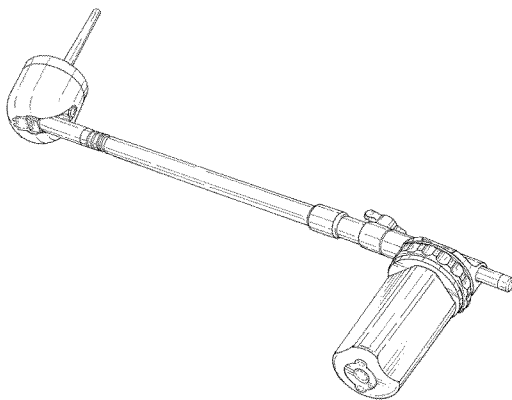

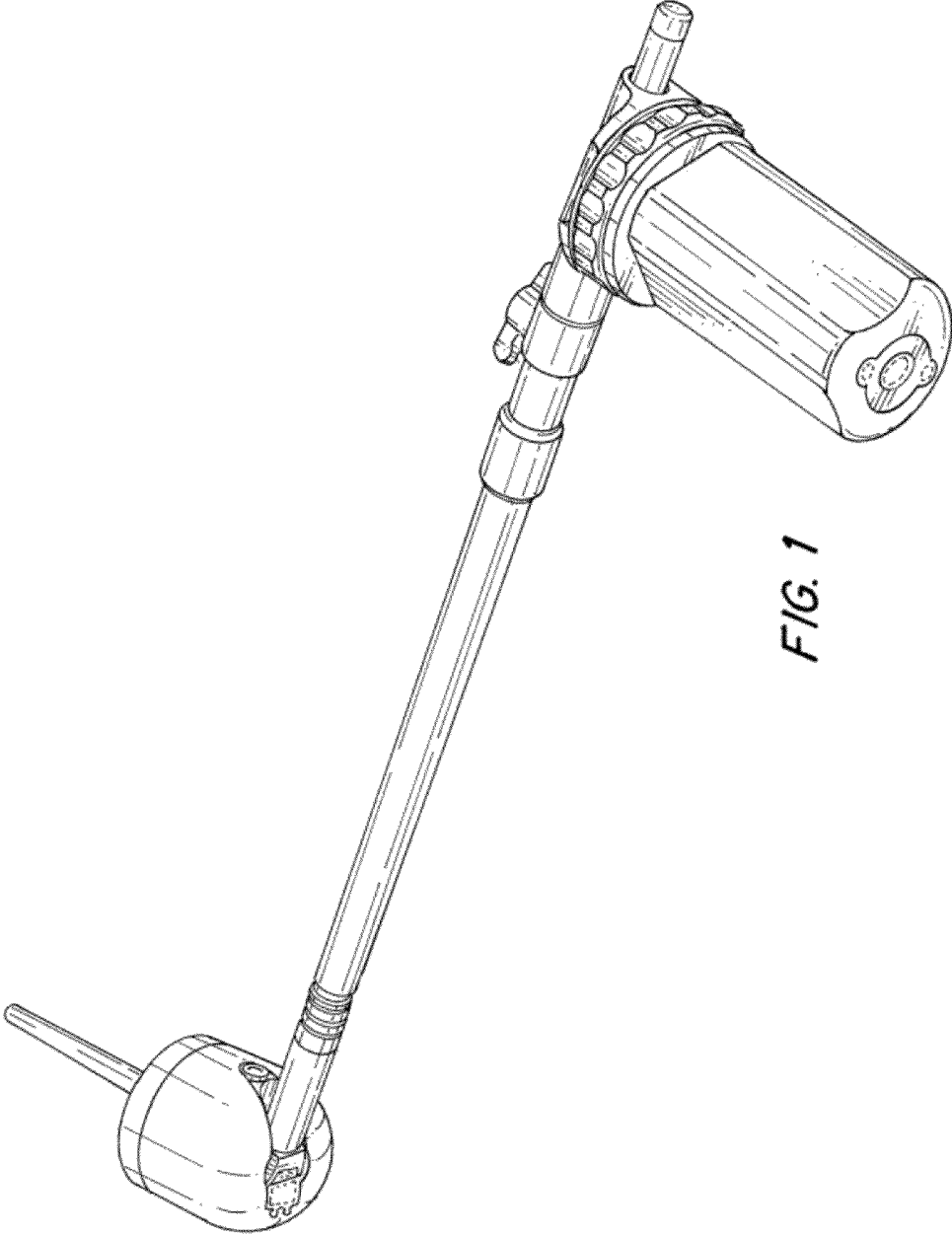

FIG. 1

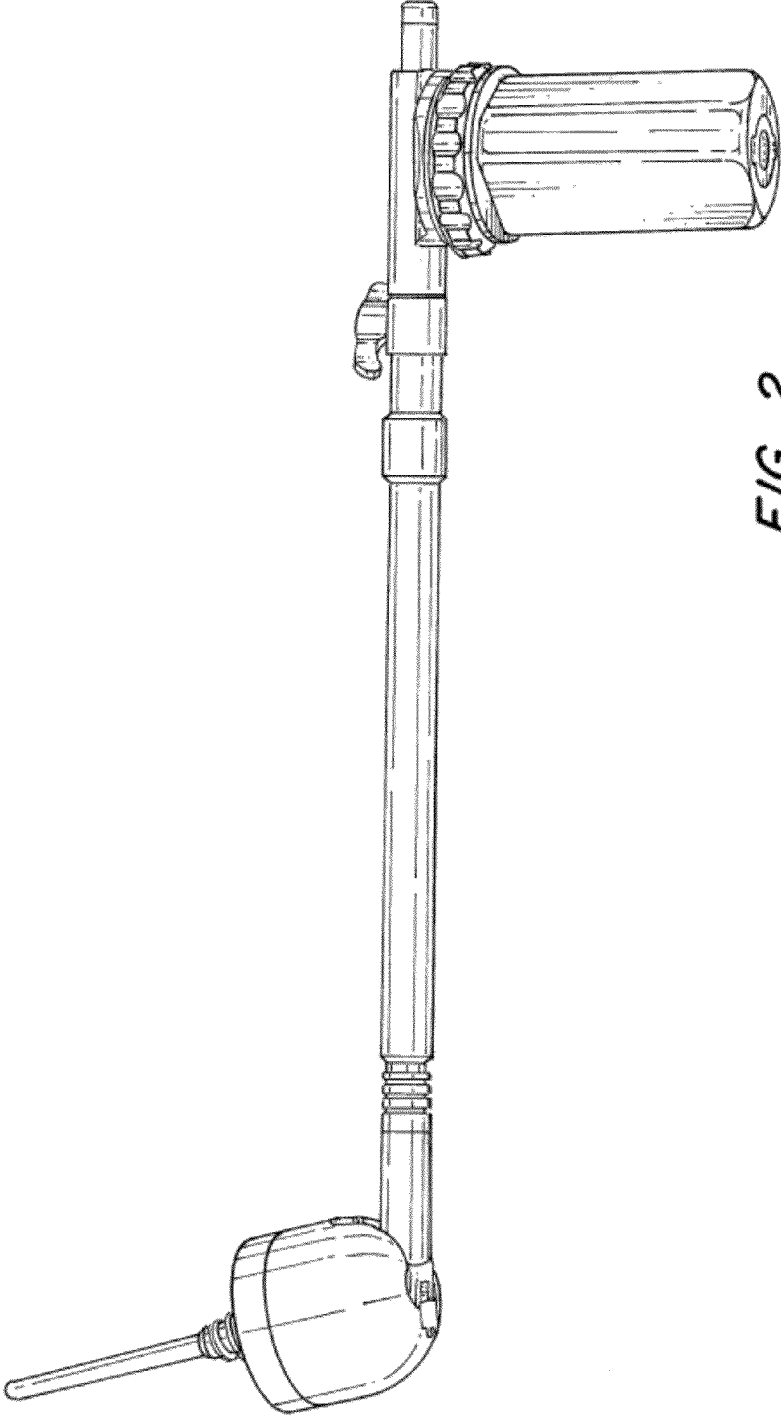

FIG. 2

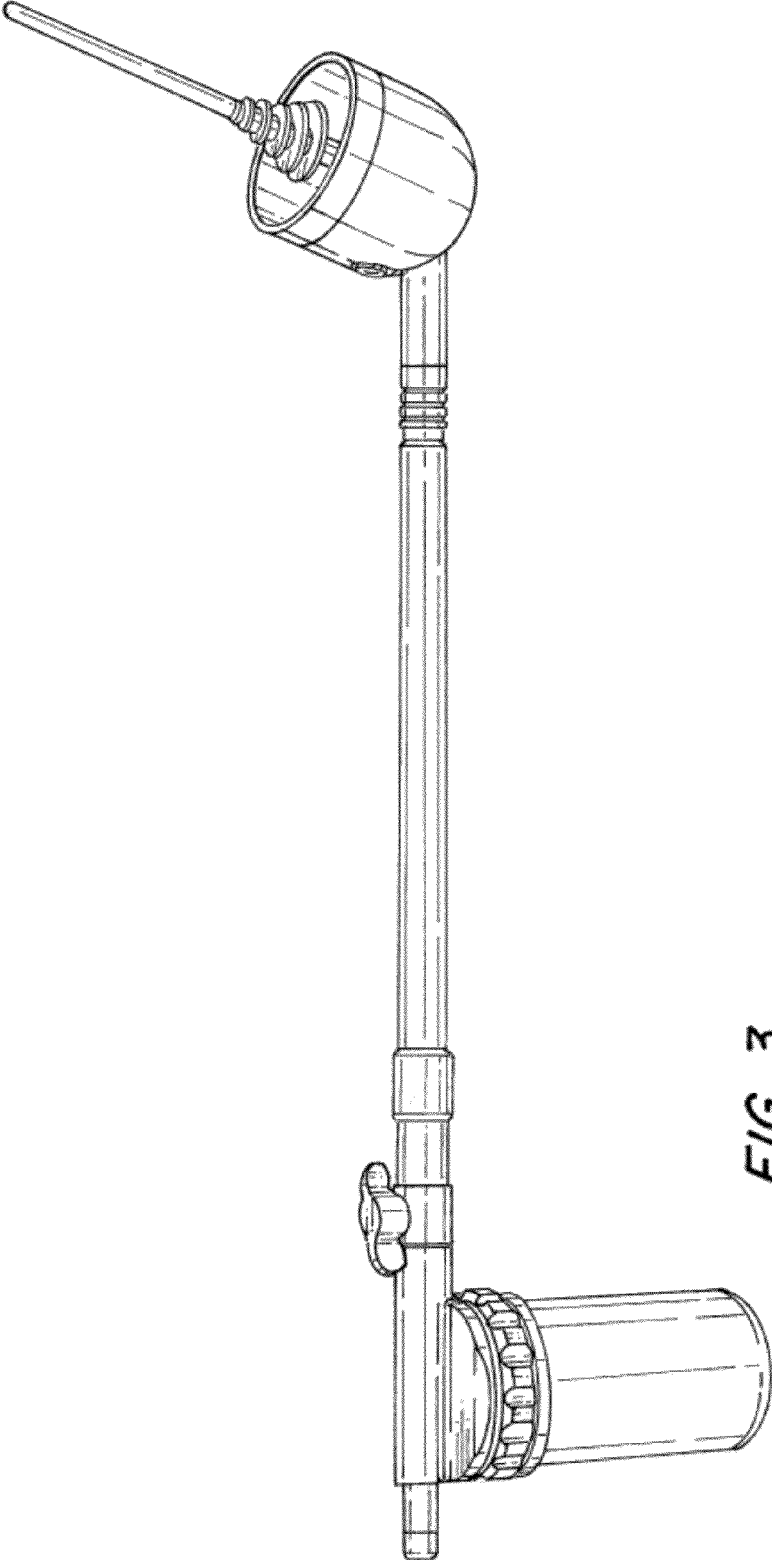

FIG. 3

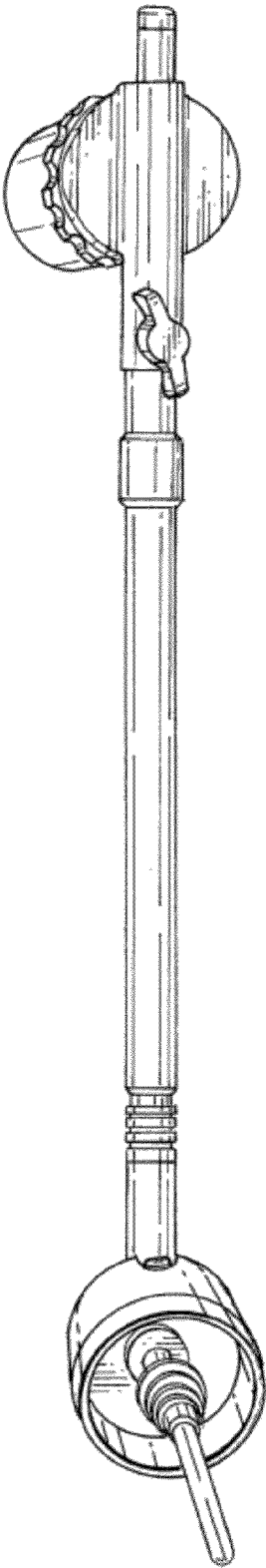

FIG. 4

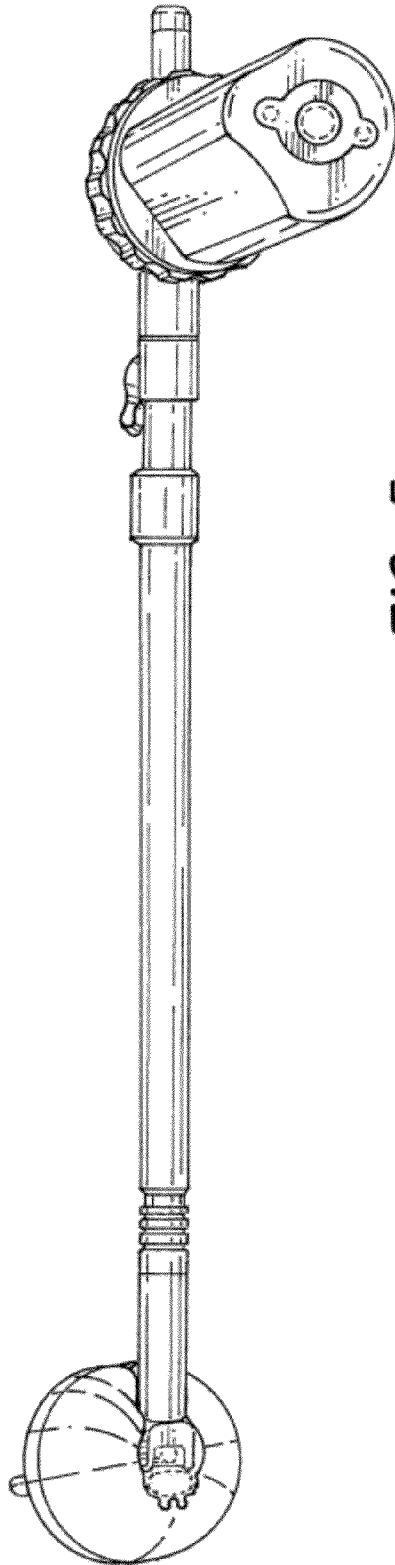

FIG. 5

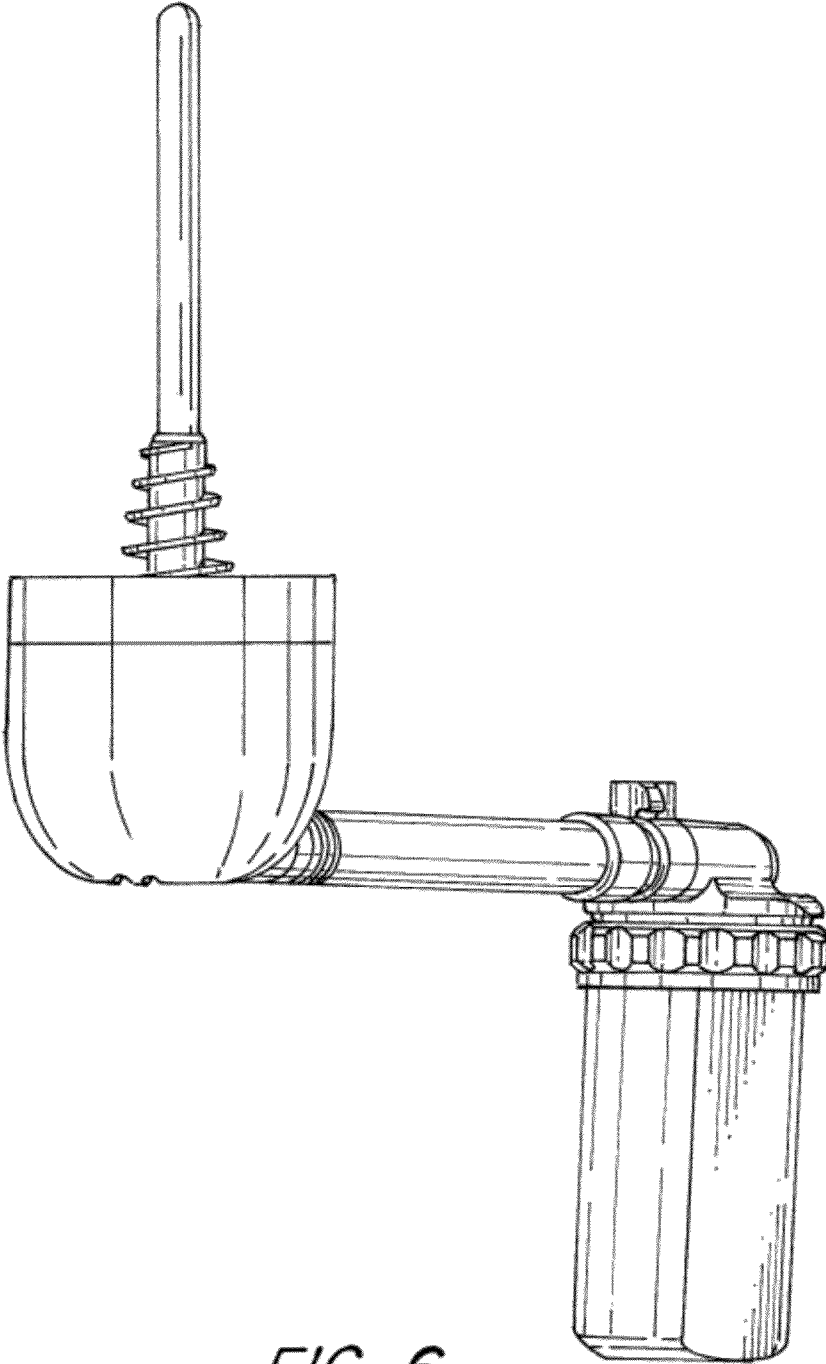

FIG. 6

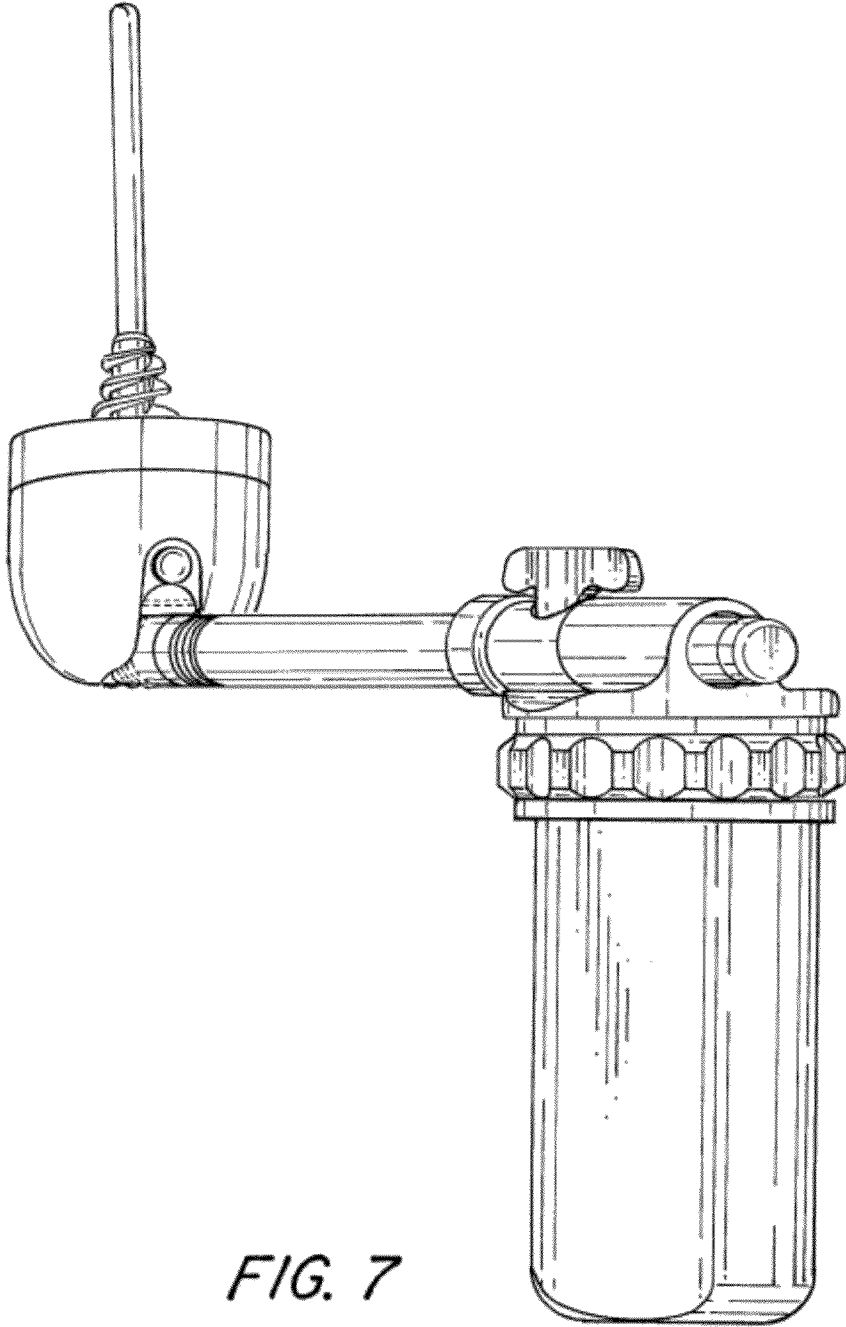

FIG. 7