

July 30, 1935.

A. POTIGIAN

2,009,590

FOLDING TABLE

Filed March 21, 1934

3 Sheets-Sheet 1

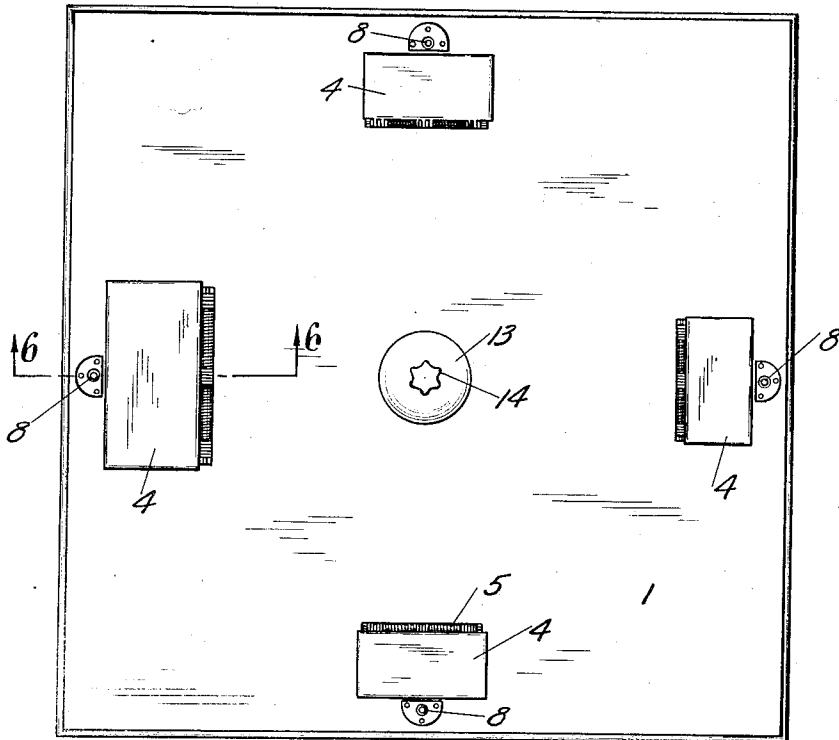

FIG-1

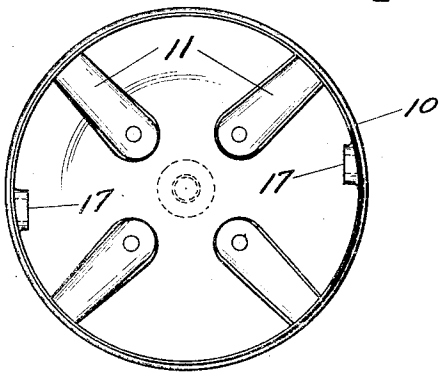

FIG-2

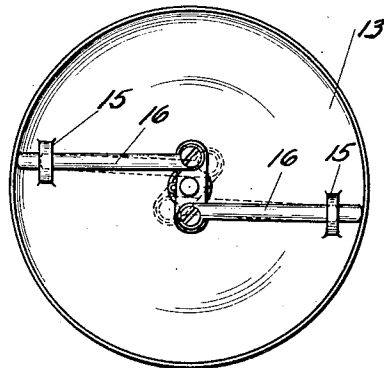

FIG-3

A. POTIGIAN INVENTOR

BY
Merrill M. Blackburn.
ATTORNEY

July 30, 1935.

A. POTIGIAN

2,009,590

FOLDING TABLE

Filed March 21, 1934

3 Sheets-Sheet 2

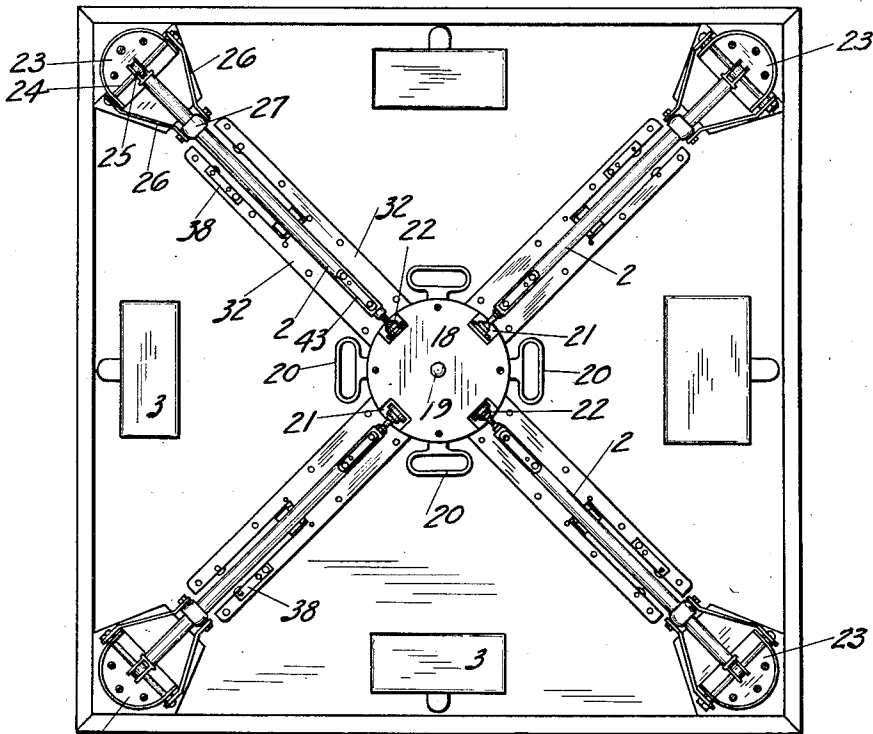

23

FIG-2

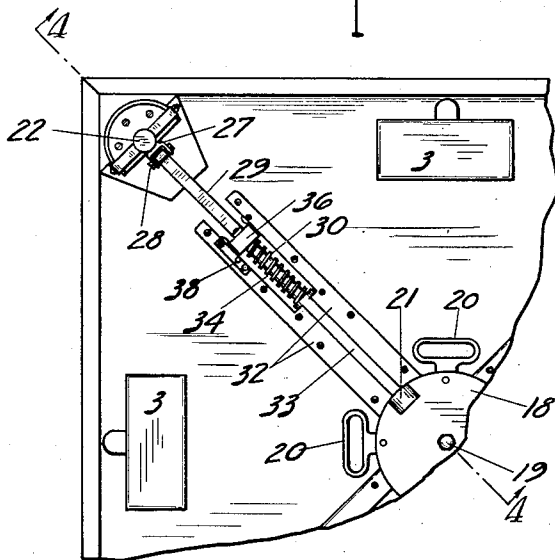

FIG-3

A. POTIGIAN INVENTOR.

BY
Merrill M. Blackburn
ATTORNEY.

July 30, 1935.

A. POTIGIAN

2,009,590

FOLDING TABLE

Filed March 21, 1934

3 Sheets-Sheet 3

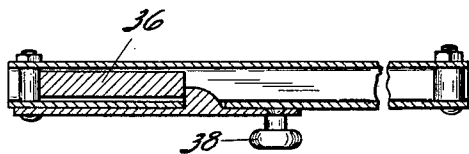
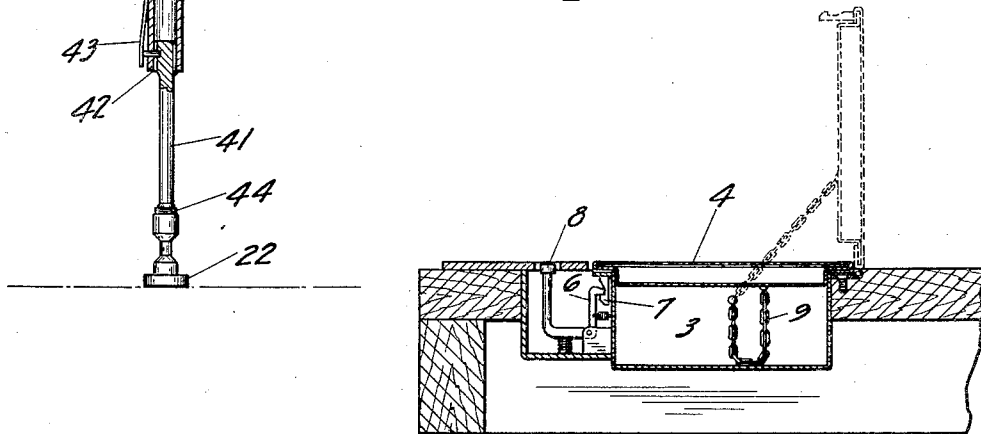
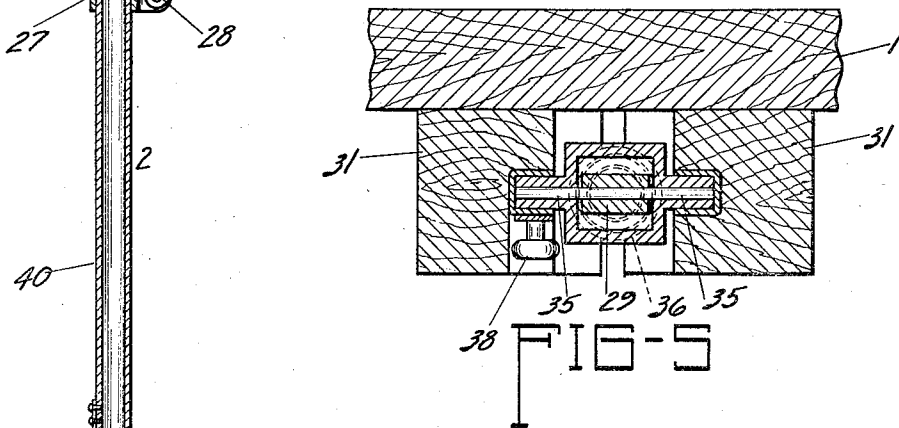
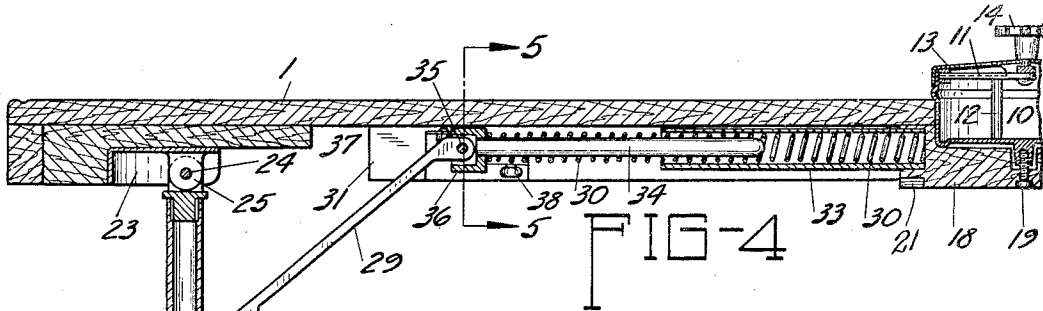

FIG-6

A. POTIGIAN INVENTOR.

FIG-7

BY
Merrill M. Blackburn
ATTORNEY.

UNITED STATES PATENT OFFICE

2,009,590

FOLDING TABLE

Armen Potigian, Davenport, Iowa

Application March 21, 1934, Serial No. 716,612

3 Claims. (Cl. 311-98)

The present invention relates to a folding table of the type commonly used for card games and comprises among its objects the provision of means near each player for the reception of cigars, packages of cigarettes, matches, and the like; the provision in the center of the table of a receptacle for ashes, said receptacle being provided with means for holding lighted cigarettes or cigars and the reception of ashes; the provision of improved adjustable folding legs; the provision of handles whereby the table may be carried, when folded; and such further objects, advantages and capabilities as will hereafter appear and as are inherent in the construction disclosed herein. My invention further resides in the combination, construction and arrangement of parts illustrated in the accompanying drawings and, while I have shown therein what is now considered the preferred embodiment of this invention, I desire the same to be understood as illustrative only and not to be interpreted in a limiting sense.

In the drawings annexed hereto and forming a part hereof,

Fig. 1 is a plan view of my improved table;

Fig. 2 is an underside view, the same being the reverse of Fig. 1;

Fig. 3 shows approximately one-quarter of the underside of the table, with the leg at that corner put into supporting position;

Fig. 4 is a central section through the structure shown in Fig. 3, the section being taken through the corner and the center of the table;

Fig. 5 is a transverse section taken substantially along the plane indicated by the line 5-5, Fig. 4;

Fig. 6 is a transverse section through one of the receptacles in the table top;

Fig. 7 is a section showing in detail a leg-locking mechanism;

Fig. 8 is a plan view of the ash receptacle with the cover removed;

Fig. 9 is an underface view of the cover for the ash receptacle.

A more detailed description will now be given in connection with the annexed drawings in which the table top is indicated by the numeral 1 and the legs by the numeral 2. Adjacent each side of the table is a metal box 3 provided with a cover 4 which is actuated into open position by means of a spring 5 and held in closed position by means of a spring-actuated latch 6 which engages a hook 7 on the under side of the cover 4 of the box. A latch-releasing button 8 is placed adjacent the near edge of the box so as to be handy

to the player. A chain 9 limits the upward swing of the cover 4, as will be evident from Fig. 6.

An ash tray 10, located at the middle of the table, has supports for cigars or cigarettes, located interiorly thereof, as indicated at 11, posts 12 providing supporting means for the inner ends of these supports 11. A cover 13, provided with a handle 14, fits outside of the receptacle 10. On the under side of the cover are apertured lugs 15 in which are slidably mounted the latching bolts 16 which are forced outwardly by rotation of the handle 14 to cause them to engage in apertures in the lugs 17 on the receptacle 10. The operation of these latching bolts will be obvious from Fig. 9.

A block 18 is secured to the underside of the table top and is recessed for the reception of the ash container 19. The latter is shown as secured to the block 18 by means of a screw 19 (see Fig. 4). Handles 20 are attached to the block 18 and serve as means whereby the table may be carried by a person, by one hand. Recesses 21 are formed in the block 18 for reception of the feet 22 of the table legs 2. In Fig. 2 the table legs shown as folded, while in Fig. 3 there is shown a single leg and this is in extended position.

At each corner of the table there is secured a support 23 in which is mounted a pivot pin 24 whereby the legs 2 are pivotally connected to the table top. The legs are shown as pivotally connected at 25 to the pivot pin 24 and as having braces 26 whereby they are braced laterally thus making their connection to the table top more rigid. Connectors 27 are secured to the legs 2 and to these are pivotally connected, as shown at 28, the links 29 by means of which the springs 30 are compressed. Blocks 31 are secured on the under side of the table top 1 and are grooved on their adjacent sides to form a retaining channel for the tubular member 33 in which is located one end portion of the spring 30. Inside of the spring 30 and slidably mounted therein is the rod 34 which is pivotally connected at 35 to the link 29 by a connecting member 36 which serves as an abutment for one end of the spring 30. The rod 34 serves as a guide for the spring so that it will be sure to enter the tube 33, when being compressed, as the leg is folded. Referring to Fig. 4, it will be seen that as the leg 2 is folded into closed position, the end of member 27 carrying the pivot 28 will enter the space 37, thus passing dead center between the pivots 24 and 35. This will naturally hold the leg in folded position but will still not make it hard to unfold

the leg to the position shown in Fig. 4. Latching means 38 is provided for latching the leg in the position shown in Fig. 4.

Each leg 2 comprises a tubular section 40 and an extension 41 which has screw-threaded connection at 42 when in the extended position shown in Fig. 4. A latch 43 is provided which engages an opening in the inner end of the extension 41 to let the user know when the extension is far enough out and to assist in holding the two parts in properly adjusted position. Screw threads at 44 may engage the screw threads in the end of the tubular section, when the leg is shortened, as indicated in Fig. 2, thus insuring that the two parts 40 and 41 will not inadvertently slide with respect to each other. In order to make it possible to make the legs 2 shorter, when folded up as in Fig. 2, the section 40 may be shortened and the section 41 lengthened. This will make it possible to bring the attaching member 23 closer to the center of the table and thereby reduce the size of the table, which is important when it is desired to have a small size table.

It will of course be understood that the specific description of structure set forth above may be departed from without departing from the spirit of this invention as set forth in this specification and the appended claims.

Having now described my invention, I claim.

1. A folding table comprising a top having legs pivotally connected to the under side thereof, a leg actuating spring, means for holding and guiding the spring, means for compressing said spring, and means connecting the last named means and a foldable leg so that when the leg is folded against the under side of the top the spring will be placed under compression and will hold the leg in folded position until released.

2. In a folding table a table top, legs pivotally connected to the under side thereof to be folded against the top, guide blocks secured to the under surface of the top, a guided member slidable between said blocks, a link connecting the guided member and a leg to be actuated thereby when the leg is folded or unfolded with relation to the top, and a compressible spring mounted on the under side of the top to be compressed by the guided member when the leg is folded against the table top.

3. A structure as defined by claim 2 having means surrounding a part of the spring and adapted to guide same and hold it in place when the leg is folded against the top, and means for latching the guided member when the spring is extended.

ARMEN POTIGIAN.