

(19) World Intellectual Property Organization
International Bureau



(43) International Publication Date
7 December 2006 (07.12.2006)

PCT

(10) International Publication Number
WO 2006/130821 A2

- (51) International Patent Classification: Not classified
- (21) International Application Number: PCT/US2006/021428
- (22) International Filing Date: 1 June 2006 (01.06.2006)
- (25) Filing Language: English
- (26) Publication Language: English
- (30) Priority Data:
60/686,683 1 June 2005 (01.06.2005) US
- (63) Related by continuation (CON) or continuation-in-part (CIP) to earlier application:
US 60/686,683 (CIP)
Filed on 1 June 2005 (01.06.2005)
- (71) Applicant (for all designated States except US): **BRONCUS TECHNOLOGIES, INC.** [US/US]; 1400 N. Shoreline Boulevard, Mountain View, CA 94043 (US).
- (72) Inventors; and
- (75) Inventors/Applicants (for US only): **ROSCHAK, Edmund, J.** [US/US]; 26262 Verona Place, Mission Viejo, CA 92692 (US). **PHAN, Loc, X.** [US/US]; 3289 Pinkerton Drive, San Jose, CA 95148 (US).
- (74) Agent: **BAGADE, Sanjay, S.**; Levine Bagade LLP, 2483 E. Bayshore Road, Suite 100, Palo Alto, CA 94303 (US).
- (81) Designated States (unless otherwise indicated, for every kind of national protection available): AE, AG, AL, AM, AT, AU, AZ, BA, BB, BG, BR, BW, BY, BZ, CA, CH, CN, CO, CR, CU, CZ, DE, DK, DM, DZ, EC, EE, EG, ES, FI, GB, GD, GE, GH, GM, HR, HU, ID, IL, IN, IS, JP, KE, KG, KM, KN, KP, KR, KZ, LC, LK, LR, LS, LT, LU, LV, LY, MA, MD, MG, MK, MN, MW, MX, MZ, NA, NG, NI, NO, NZ, OM, PG, PH, PL, PT, RO, RU, SC, SD, SE, SG, SK, SL, SM, SY, TJ, TM, TN, TR, TT, TZ, UA, UG, US (patent), UZ, VC, VN, YU, ZA, ZM, ZW.
- (84) Designated States (unless otherwise indicated, for every kind of regional protection available): ARIPO (BW, GH, GM, KE, LS, MW, MZ, NA, SD, SL, SZ, TZ, UG, ZM, ZW), Eurasian (AM, AZ, BY, KG, KZ, MD, RU, TJ, TM), European (AT, BE, BG, CH, CY, CZ, DE, DK, EE, ES, FI, FR, GB, GR, HU, IE, IS, IT, LT, LU, LV, MC, NL, PL, PT, RO, SE, SI, SK, TR), OAPI (BF, BJ, CF, CG, CI, CM, GA, GN, GQ, GW, ML, MR, NE, SN, TD, TG).
- Published:**
— without international search report and to be republished upon receipt of that report
- For two-letter codes and other abbreviations, refer to the "Guidance Notes on Codes and Abbreviations" appearing at the beginning of each regular issue of the PCT Gazette.*



WO 2006/130821 A2

(54) Title: METHODS AND DEVICES FOR MAINTAINING SURGICALLY CREATED CHANNELS IN A BODY ORGAN

(57) Abstract: This is directed to methods and devices suited for maintaining an opening in a wall of a body organ for an extended period. More particularly devices and methods are directed maintaining patency of channels that alter gaseous flow within a lung to improve the expiration cycle of, for instance, an individual having chronic obstructive pulmonary disease.

METHODS AND DEVICES FOR MAINTAINING PATENCY OF SURGICALLY CREATED CHANNELS IN A BODY ORGAN

CROSS-REFERENCE TO RELATED APPLICATIONS

[0001] This application is a non-provisional of U.S. Provisional Application No. 60/686,683, filed June 1, 2005, and is also a continuation-in-part of U.S. Application No. 10/895,256, filed July 19, 2004, which is a continuation-in-part of U.S. Patent Application No. 10/633,902, filed on August 4, 2003, which is continuation of U.S. Application No. 09/633,651, now U.S. Patent No. 6,692,494 B1, which is a non-provisional of U.S. Provisional Application No. 60/147,528, filed August 5, 1999, and a non-provisional of U.S. Provisional Application 60/176,141, filed January 14, 2000. This application is also a continuation-in-part of U.S. Application No. 10/458,085, filed June 9, 2003. The entirety of each of the above are hereby incorporated by reference.

BACKGROUND OF THE INVENTION

[0002] The American Lung Association (ALA) estimates that nearly 16 million Americans suffer from chronic obstructive pulmonary disease (COPD) which includes diseases such as chronic bronchitis, emphysema, and some types of asthma. The ALA estimated that COPD was the fourth-ranking cause of death in the U.S. The ALA estimates that about 14 million and 2 million Americans suffer from emphysema and chronic bronchitis respectively.

[0003] Those inflicted with COPD face disabilities due to the limited pulmonary functions. Usually, individuals afflicted by COPD also face loss in muscle strength and an inability to perform common daily activities. Often, those patients desiring treatment for COPD seek a physician at a point where the disease is advanced. Since the damage to the lungs is irreversible, there is little hope of recovery. Most times, the physician cannot reverse the effects of the disease but can only offer treatment and advice to halt the progression of the disease.

[0004] To understand the detrimental effects of COPD, the workings of the lungs requires a cursory discussion. The primary function of the lungs is to permit the exchange of two gasses by removing carbon dioxide from arterial blood and replacing it with oxygen. Thus, to facilitate this exchange, the lungs provide a blood gas interface. The oxygen and carbon dioxide move between the gas (air) and blood by diffusion. This diffusion is possible since the blood is delivered to one side of the blood-gas interface via small blood

vessels (capillaries). The capillaries are wrapped around numerous air sacs called alveoli which function as the blood-gas interface. A typical human lung contains about 300 million alveoli.

[0005] The air is brought to the other side of this blood-gas interface by a natural respiratory airway, hereafter referred to as a natural airway or airway, consisting of branching tubes which become narrower, shorter, and more numerous as they penetrate deeper into the lung. Specifically, the airway begins with the trachea which branches into the left and right bronchi which divide into lobar, then segmental bronchi. Ultimately, the branching continues down to the terminal bronchioles which lead to the alveoli. Plates of cartilage may be found as part of the walls throughout most of the airway from the trachea to the bronchi. The cartilage plates become less prevalent as the airways branch. Eventually, in the last generations of the bronchi, the cartilage plates are found only at the branching points. The bronchi and bronchioles may be distinguished as the bronchi lie proximal to the last plate of cartilage found along the airway, while the bronchiole lies distal to the last plate of cartilage. The bronchioles are the smallest airways that do not contain alveoli. The function of the bronchi and bronchioles is to provide conducting airways that lead air to and from the gas-blood interface. However, these conducting airways do not take part in gas exchange because they do not contain alveoli. Rather, the gas exchange takes place in the alveoli which are found in the distal most end of the airways.

[0006] The mechanics of breathing include the lungs, the rib cage, the diaphragm and abdominal wall. During inspiration, inspiratory muscles contract increasing the volume of the chest cavity. As a result of the expansion of the chest cavity, the pleural pressure, the pressure within the chest cavity, becomes sub-atmospheric. Consequently, air flows into the lungs and the lungs expand. During unforced expiration, the inspiratory muscles relax and the lungs begin to recoil and reduce in size. The lungs recoil because they contain elastic fibers that allow for expansion, as the lungs inflate, and relaxation, as the lungs deflate, with each breath. This characteristic is called elastic recoil. The recoil of the lungs causes alveolar pressure to exceed atmospheric pressure causing air to flow out of the lungs and deflate the lungs. 'If the lungs' ability to recoil is damaged, the lungs cannot contract and reduce in size from their inflated state. As a result, the lungs cannot evacuate all of the inspired air.

[0007] In addition to elastic recoil, the lung's elastic fibers also assist in keeping small airways open during the exhalation cycle. This effect is also known as "tethering" of the

airways. Tethering is desirable since small airways do not contain cartilage that would otherwise provide structural rigidity for these airways. Without tethering, and in the absence of structural rigidity, the small airways collapse during exhalation and prevent air from exiting thereby trapping air within the lung.

[0008] Emphysema is characterized by irreversible biochemical destruction of the alveolar walls that contain the elastic fibers, called elastin, described above. The destruction of the alveolar walls results in a dual problem of reduction of elastic recoil and the loss of tethering of the airways. Unfortunately for the individual suffering from emphysema, these two problems combine to result in extreme hyperinflation (air trapping) of the lung and an inability of the person to exhale. In this situation, the individual will be debilitated since the lungs are unable to perform gas exchange at a satisfactory rate.

[0009] One further aspect of alveolar wall destruction is that the airflow between neighboring air sacs, known as collateral ventilation or collateral air flow, is markedly increased as when compared to a healthy lung. While alveolar wall destruction decreases resistance to collateral ventilation, the resulting increased collateral ventilation does not benefit the individual since air is still unable to flow into and out of the lungs. Hence, because this trapped air is rich in CO₂, it is of little or no benefit to the individual.

[0010] Chronic bronchitis is characterized by excessive mucus production in the bronchial tree. Usually there is a general increase in bulk (hypertrophy) of the large bronchi and chronic inflammatory changes in the small airways. Excessive amounts of mucus are found in the airways and semisolid plugs of this mucus may occlude some small bronchi. Also, the small airways are usually narrowed and show inflammatory changes.

[0011] Currently, although there is no cure for COPD, treatment includes bronchodilator drugs, and lung reduction surgery. The bronchodilator drugs relax and widen the air passages thereby reducing the residual volume and increasing gas flow permitting more oxygen to enter the lungs. Yet, bronchodilator drugs are only effective for a short period of time and require repeated application. Moreover, the bronchodilator drugs are only effective in a certain percentage of the population of those diagnosed with COPD. In some cases, patients suffering from COPD are given supplemental oxygen to assist in breathing. Unfortunately, aside from the impracticalities of needing to maintain and transport a source of oxygen for everyday activities, the oxygen is only partially functional and does not eliminate the effects of the COPD. Moreover, patients requiring a supplemental source of oxygen are usually never able to return to functioning without the oxygen.

[0012] Lung volume reduction surgery is a procedure which removes portions of the lung that are over-inflated. The portion of the lung that remains has relatively better elastic recoil, providing reduced airway obstruction. The reduced lung volume also improves the efficiency of the respiratory muscles. However, lung reduction surgery is an extremely traumatic procedure which involves opening the chest and thoracic cavity to remove a portion of the lung. As such, the procedure involves an extended recovery period. Hence, the long term benefits of this surgery are still being evaluated. In any case, it is thought that lung reduction surgery is sought in those cases of emphysema where only a portion of the lung is emphysematous as opposed to the case where the entire lung is emphysematous. In cases where the lung is only partially emphysematous, removal of a portion of emphysematous lung which was compressing healthier portions of the lung allows the healthier portions to expand, increasing the overall efficiency of the lung. If the entire lung is emphysematous, however, removal of a portion of the lung removes gas exchanging alveolar surfaces, reducing the overall efficiency of the lung. Lung volume reduction surgery is thus not a practical solution for treatment of emphysema where the entire lung is diseased. Moreover, conventional lung volume reduction surgery is an open surgical procedure which carries the risk of surgical complications and requires a significant period of time for recuperation.

[0013] Both bronchodilator drugs and lung reduction surgery fail to capitalize on the increased collateral ventilation taking place in the diseased lung. There remains a need for a medical procedure that can alleviate some of the problems caused by COPD. There is also a need for a medical procedure that alleviates some of the problems caused by COPD irrespective of whether a portion of the lung, or the entire lung is emphysematous. The production and maintenance of collateral openings through an airway wall allows air to pass directly out of the lung tissue responsible for gas exchange. These collateral openings serve to decompress hyper inflated lungs and/or facilitate an exchange of oxygen into the blood.

[0014] Methods and devices for creating and maintaining collateral channels are discussed in U.S. Patent Application No. 09/633,651, filed on August 7, 2000; U.S. Patent Application Nos. 09/947,144, 09/946,706, and 09/947,126 all filed on September 4, 2001; U.S. Provisional Application No. 60/317,338 filed on September 4, 2001; U.S. Provisional Application No. 60/334,642 filed on November 29, 2001; U.S. Provisional Application No. 60/367,436 filed on March 20, 2002; and U.S. Provisional Application No. 60/374,022 filed on April 19, 2002 each of which is incorporated by reference herein in its entirety.

[0015] Although creating an opening through an airway wall may overcome the shortcomings associated with bronchodilator drugs and lung volume reduction surgery, various problems can still arise. When a hole is surgically created in tissue the healing cascade is triggered. This process is characterized by an orderly sequence of events, which can be broadly classified into distinct phases. These phases proceed in a systematic fashion, with a high degree of integration, organization, and control. However, the various stages are not sharply delineated, but overlap considerably, and factors affecting one phase have a stimulatory or inhibitory effect on the overall process.

[0016] The result of this wound healing process is tissue proliferation that can occlude or otherwise close the surgically created opening. Additionally, in the event an implant is deployed in the surgically created opening to maintain the patency of the opening, the implant may become encapsulated or filled with tissue thereby occluding the channel.

[0017] Drug eluting coronary-type stents are not known to overcome the above mentioned events because these stents are often substantially cylindrical (or otherwise have a shape that conforms to the shape of a tubular blood vessel). Hence, they may slide and eject from surgically created openings in an airway wall leading to rapid closure of any channel. Additionally, the design and structure of the coronary-type stents reflect the fact that these stents operate in an environment that contains different tissues when compared to the airways not to mention an environment where there is a constant flow of blood against the stent. Moreover, the design of coronary stents also acknowledges the need to place the stent within a tubular vessel and avoid partial re-stenosis of the vessel after stent placement so that blood may continue to flow. In view of the above, implants suited for placement in the coronary are often designed to account for factors that may be insignificant when considering a device for the airways.

[0018] Not surprisingly, experiments in animal models found that placement of coronary drug eluting stents (i.e., paclitaxel drug eluting vascular stents and sirolimus drug eluting stents) into the airway openings did not yield positive results in maintaining the patency of the opening. The shortcomings were both in the physical structure of the stent which did not lend itself to the airways as well as the inability of those drug eluting devices to control the healing cascade caused by creation of the channel. The majority of these devices filled with tissue at an early stage and an inspection of the remainder of the implanted devices indicated imminent closure.

[0019] An understanding of the distinctions between the healing response in the coronary versus the airways may explain this outcome. For purposes of our discussion, the

healing response in both the coronary and the lungs may be divided into approximately four stages as measured relative to the time of the injury: 1) acute phase; 2) sub-chronic phase; 3) chronic phase; and 4) late phase.

[0020] In the coronary, after trauma caused by the placement of a coronary stent, the healing process begins in the acute phase with thrombus and acute inflammation. During the sub-chronic phase, there is an organization of the thrombus, an acute/chronic inflammation and early neointima hyperplasia. In the following chronic phase, there is a proliferation of smooth muscle cells along with chronic inflammation and adventitial thickening. In the late stage of the healing process there is chronic inflammation, neointimal remodeling, medial hypertrophy and adventitial thickening.

[0021] Based upon the observations in a rabbit model, the healing response in the airway begins with a fibrinous clot, edema hemorrhage, and fibrin deposition. In the sub-chronic phase there is re-epithelialization, mucosal hypertrophy, squamous metaplasia, fibroplasias and fibrosis. In the chronic phase, while the epithelium is intact and there is less mucosal hypertrophy, there is still fibroplasia and fibrosis. In the late stage the respiratory epithelium is intact and there is evidence of a scar.

[0022] Accordingly, the unique requirements of the airways and collateral channels calls for specific features for any implant used in collateral channels. For example, these implants/conduits are often placed across three different tissue zones; namely the parenchyma, the newly sectioned airway wall, and the interior of the airway surface. Each different zone may have a different reaction to the presence of the implant/conduit. The parenchyma may build up a layer of scar tissue around the conduit, which may eventually eject the implant or block the air path on the parenchyma side of the conduit. The airway wall may undergo a healing response as a result of the trauma of the procedure. This healing response and associated tissue growth may restrict air-flow through the implant. Furthermore, mucus from the airways may deposit in to the conduit thereby further occluding the conduit.

[0023] In addition, placement of an implant or conduit within the collateral channel may present additional structure requirements for the devices. For example, surgeons often use radiological imaging to place coronary stents within the vasculature. In most cases, placement of coronary stents is critical so that the ends of the coronary stent straddle the vascular obstruction. In contrast, a surgeon placing an implant in collateral channels is often using a remote access device such as a bronchoscope or endoscope that allows for direct observation of the device during placement. For proper placement of the implant,

and in cases where it is important to “sandwich” the airway wall, it is necessary to identify the center and/or edges of the conduit or implant prior to expansion of the device. It follows that failure to properly place the implant may result in detachment of the implant (via insufficient attachment to the airway wall), pneumothorax (if the implant is advanced too distally and breaches the pleural cavity), or deployment of the implant wholly in the lung parenchyma exterior to the airway wall. Accordingly, such devices may require a visual indicator to assist the medical practitioner during placement and to offer a measure of safety so that the device is not improperly advanced/deployed thus creating additional complications.

[0024] Accordingly, there remains a need for devices and methods that specifically address the requirements discussed herein.

BRIEF SUMMARY OF THE INVENTION

[0025] The devices and methods described herein serve to maintain the patency of a channel surgically created in an organ such as an airway wall. In particular, the devices and methods are suited for placement within a channel created within the airway wall and prevent closure of the channel such that air may flow through the channel and into the airway.

[0026] It is noted that the devices and methods described herein have particular use for individuals having emphysema and COPD. However, the devices and methods could also benefit any individuals having hyperinflation of the lungs.

[0027] Delivery devices for delivering the implants and/or creating the opening are described in U.S. Provisional Application No. 60/488,33, filed 7/18/2003, the entirety of which is herein incorporated by reference.

[0028] Implants of the present invention may include a support member having a structure that is adapted for placement within a wall of a body organ, especially an airway wall.

[0029] When used in the lungs implants of the present invention modifies the healing response of the lung tissue (e.g., at the site of newly created hole/channel) for a sufficient time until the healing response of the lung tissue subsides or reduces such that the hole/channel becomes a persistent air path. For example, the implant and bioactive substance will modify the healing response for a sufficient time until the healing response

is reduced and, from a visual observation, the body treats the opening essentially as a natural airway passage rather than as an injury to the airway wall.

[0030] Variations of the invention include implants having compositions comprising a polymer which either serves as a carrier for the agent or as a delivery barrier for the agent. In those variations of the implant used in the airways, the composition may provide a steady release rate of bio-active substance as well as have a sufficient amount of available bio-active substance to modify the healing response of the lung tissue. As described herein, such a delivery system takes advantage of the tissue environment surrounding the airways.

[0031] The antiproliferative agent of the present invention is one that modifies a healing response. Various agents are discussed below, examples include a microtubule stabilizing agent such as taxol or paclitaxel, or a microtubule destabilizing agent such as vincristine, vinblastine, podophylotoxin, estramustine, noscapine, griseofulvin, dicoumarol, a vinca alkaloid, or a combination thereof. Furthermore, the agent may include steroids, non-steroidal anti-inflammatories, rapamycin, dactinomycin, sirolimus, everolimus, Abt-578, tacrolimus, and a combination thereof. It is noted that the composition or implant may also include additional substance as required by the location of the implant. Such substances may affect/suppress mucus production, provide protection against bacteria, or maintain sterility of the implant site or surrounding tissue. It is contemplated that the bio-active substances listed herein includes all forms of the substances (e.g., analogs, derivatives, salt forms and crystalline forms.)

[0032] Variations of the invention also may include visualization features which provide assistance when attempting to place the implant from within an organ and having no or little direct visibility outside of the organ.

[0033] The invention may also include additional features such as valves within the implant to regulate flow or provide a protective barrier.

[0034] This application is also related to the following applications 60/420,440 filed 10/21/2002; 60/387,163 filed 6/7/2002; 10/235,240 filed 9/4/02; 09/947,144 filed 9/4/01; 09/908,177 filed 7/18/01; 09/633,651 filed 8/7/00; and 60/176,141 filed 1/14/00; 10/080,344 filed 2/21/02; 10/079,605 filed 2/21/02; and 10/280,851 filed 10/25/02. Each of which is incorporated by reference herein. Accordingly, where not inconsistent with the principles described herein, features and aspects of the invention may be combined with the various implants and conduits described in the above related applications.

BRIEF DESCRIPTION THE DRAWINGS

[0035] Figures 1A-1C illustrate various states of the natural airways and the blood-gas interface.

[0036] Figure 1D illustrates a schematic of a lung demonstrating a principle of the invention described herein.

[0037] Figures 2A-2B illustrates deployment of an implant of the present invention.

[0038] Figures 3A-3C provide various views of a variation of an implant of the present invention.

[0039] Figures 4A-4C are views of an additional variation of the invention.

[0040] Figures 5A-5G illustrate additional variations of the invention.

[0041] Figures 5D-5F illustrate variations of the invention forming

[0042] Figure 6 illustrates a variation of the implant where the proximal and distal ends of the support member comprise wall retaining.

[0043] Figures 7A-7C illustrate a variation of the invention where the proximal portion and the distal portion are of differing sizes.

[0044] Figures 8A-8B illustrate additional variations of delivering an bioactive agent with the present invention.

[0045] Figures 9A-9C illustrate variations of the present invention having visualization marks or features.

[0046] Figure 10A-10B illustrate histology samples comparing conventional devices and an implant having a antiproliferative substance in accordance .

[0047] Figure 11 illustrates *pre-clinical data of an animal model comparing* conventional devices, coronary drug eluting stents, and implants of the present invention.

DETAILED DESCRIPTION

[0048] Described herein are devices (and methods) for improving the gas exchange in the lung. In particular, methods and devices are described that serve to maintain and extend the patency of collateral openings or channels through an airway wall so that air is able to pass directly out of the lung tissue and into the airways. This facilitates exchange of oxygen into the blood and decompresses hyper inflated lungs.

[0049] By "channel" it is meant to include, but not be limited to, any opening, hole, slit, channel or passage created in the tissue wall (e.g., airway wall). The channel may be created in tissue having a discrete wall thickness and the channel may extend all the way

through the wall. Also, a channel may extend through lung tissue which does not have well defined boundaries such as, for example, parenchymal tissue.

[0050] Figures 1A-1C are simplified illustrations of various states of a natural airway and a blood gas interface found at a distal end of those airways. Figure 1A shows a natural airway **100** which eventually branches to a blood gas interface **102**.

[0051] Although not shown, the airway comprises an internal layer of epithelial pseudostratified columnar or cuboidal cells. Mucous secreting goblet cells are also found in this layer and cilia may be present on the free surface of the epithelial lining of the upper respiratory airways. Supporting the epithelium is a loose fibrous, glandular, vascular lamina propria including mobile fibroblasts. Deep in this connective tissue layer is supportive cartilage for the bronchi and smooth muscle for the bronchi and bronchioles.

[0052] Figure 1B illustrates an airway **100** and blood gas interface **102** in an individual having COPD. The obstructions **104** impair the passage of gas between the airways **100** and the interface **102**. Figure 1C illustrates a portion of an emphysematous lung where the blood gas interface **102** expands due to the loss of the interface walls **106** which have deteriorated due to a bio-chemical breakdown of the walls **106**. Also depicted is a constriction **108** of the airway **100**. It is generally understood that there is usually a combination of the phenomena depicted in Figures 1A-1C. Often, the states of the lung depicted in Figures 1B and 1C may be found in the same lung.

[0053] Figure 1D illustrates airflow in a lung **118** when implants **200** are placed in collateral channels **112**. As shown, collateral channels **112** (located in an airway wall) place lung tissue parenchyma **116** in fluid communication with airways **100** allowing air to pass directly out of the airways **100** whereas constricted airways **108** may ordinarily prevent air from exiting the lung tissue parenchyma **116**. While the invention is not limited to the number of collateral channels which may be created, it is to be understood that 1 or 2 channels may be placed per lobe of the lung and perhaps, 2-12 channels per individual patient. However, as stated above, the invention includes the creation of any number of collateral channels in the lung. This number may vary on a case by case basis. For instance, in some cases in an emphysematous lung, it may be desirable to place 3 or more collateral channels in one or more lobes of the lung.

[0054] Figures 2A-2B illustrate deployment of a variation of an implant **200** of the present invention. As discussed herein, the implant **200** is well suited for maintaining an opening in a wall of a body organ. In this example, the illustration depicts the implant **200** as deployed into a collateral channel **112** formed in a wall of an airway **100**. Referring to

Figure 2A, a delivery device **300** carrying the implant **200** is advanced to the site and inserted into the channel **112**. The delivery device **300** may optionally be constructed to also form the channel **112**. Furthermore, the delivery device **300** may extend from an access device such as an endoscope or bronchoscope **302**, or it may be directly advanced to the site.

[0055] Figure 2B illustrates the implant **200** once deployed in the airway wall **100**. As shown, the delivery device **300** inserts the implant **200** into the airway wall **100**. This variation of the implant **200** is not expandable (though it may be compressible).

Furthermore, the implant will have tissue retaining members **226** and **228** to assist in retaining the implant **200** within the airway wall **100**. The tissue retaining members **226** and **228** will have an increased diameter such that they limiting movement of the implant **200** within the tissue opening and securing the implant **200** about the perimeter of the tissue opening in the airway wall.

[0056] As noted above, the implant is suited for placement about an opening in the wall of an organ. In some cases, the implant is suited to placement in an organ having a thin wall. Through observation, applicants noted that airway wall thickness is fairly proportional to the diameter of the airway lumen by approximately a factor of 1/6. While the invention is not limited to use in any particular sized airway, on average the implant is placed in airways ranging from 3 mm to 15 mm in diameter with respective airway wall thicknesses of 0.5mm to 2.5 mm. Therefore, in many variations of the invention, the implant **200** and associated tissue retaining members **226** and **228** will be suitable to retain itself on the relatively thin airway wall tissue.

[0057] As described below, the implants of the present invention include a support member and a composition that maintain patency of the channel. Variations of the invention include support members selected from a mesh or woven structure either of which are comprised of a metal alloy (e.g., stainless, a shape-memory alloy, etc.), a polymer, a ceramic, or a combination thereof. The support member provides a structure that mechanically maintains patency of the channel as well as provides a delivery means for the composition or other substances as described herein. It is specifically noted that while the variations of the present invention are suited for use in the airways, the invention is not limited to such applications. Rather, the variations of the present invention may be used in various applications as appropriate.

[0058] Figure 3A illustrates a cross sectional view of a variation of an implant **200** where the support member **202** has proximal and distal portions with respective wall

retaining members **226** and **228**. The support member **202** also includes a mid portion **208** between the wall retaining members. **204**. As illustrated, the mid portion **208** has a smaller profile or diameter than the retaining members. Furthermore, the wall retaining members **226** and **228** in this variation are tapered to assist with insertion of the device into the airway. Although both ends show the taper, variations include implants **200** with only the distal retaining member **228** being tapered. As illustrated, the implant **200** includes a passage **230** extending through the implant **200** to allow for the escape of trapped gasses from the lung.

[0059] Figure 3B illustrates another variation of an implant **200** of the present invention. In this variation, the implant **200** may be configured so that the wall retaining members **226** and **228** are not located on the ends of the support member **202**.

[0060] Figure 3C illustrates another variation of an implant **200** of the present invention having a way valve **224** within the passage **230**. It is noted that the length of the mid-portion **208** as shown in Figures 3A-3C is for illustrative purposes. The actual length of the mid-portion **208** along with its profile may vary to accommodate the thickness of the tissue at the intended target site. For example, the mid portion **208** may have a small length when compared to the diameter of the implant **200**. Alternatively or in combination, the mid-portion **208** may be tapered, have a curved profile, an irregular profile, etc. Such profiles may assist in keeping the implant retaining in the tissue.

[0061] Figure 4A illustrates an example of an implant **200** having wall retaining members or flanges **226** and **228** at either or both ends of the support member **202**. Although not shown, the flanges **226** and **228** may have a cone-like profile to facilitate placement within an airway. The flanges **226** and **228** may also be comprised of a flexible material to permit insertion of the implant into the airway wall given the application of force. As illustrated in figure 4B, the asymmetrical profile of the implant **200** may assist in preventing obstruction of the airway.

[0062] Figure 4C illustrate a variation of an implant **200** having a self-cleaning mechanism located in the passage **230**. In this example, the self cleaning mechanism is a floating ball bearing **232**. The ends of the implant **200** have a reduced diameter in the passageway **230** which prevents the bearing **232** from escaping. As gas passes through the implant **200**, the bearing **232** moves about the implant **200** clearing it of debris. The shape of the bearing **232** and the size and shape of the reduced diameter may be varied to optimize the self-cleaning effect of the device.

[0063] Figures 5A-5C illustrate another variation of a support member 202 for an implant 200 of the present invention. Figure 5A illustrates an implant 200 having a non-expandable mid-portion 208 and deformable ends or wall retaining members 226 and 228 located at the proximal and distal ends of the device. In one variation the ends 226 and 228 of the support member 202 may flare outwards as illustrated in figure 5B. Figure 5C illustrates another variation of the device 200 in which the ends 226 and 228 compress in length to expand in diameter. It is noted that variations of the invention include non-expandable portions that are compressible.

[0064] Figure 5D illustrates a variation of a support member 202 of an implant 200 of the present invention. In this variation, the support member 202 may be formed from a sheet of material having extension members or wall retaining members 226 and 228 extending from either end of the support member 202. Although the support member 202 is illustrated to be solid, there may be openings within the mid portion 208 of the support member 202. Figure 5E illustrates the support member 202 prior to insertion into an airway wall. As illustrated in Figure 5F, the ends of each wall retention member 226 and 228 bend away from a central axis of the support member 202.

[0065] In those cases where the implant 200 of figure 5E comprises a non-shape memory alloy, the implant 200 will be actively mechanically expanded. In those cases where the implant 200 comprises a shape memory alloy, such as a super-elastic alloy, the implant 200 may be pre-formed to assume a deployed shape which includes a grommet formed by wall retention member 226 and 228 and a mid portion 208, such as the shape illustrated in Figure 5F.

[0066] Figure 5G illustrates another variation of an implant 200 of the present invention. In this variation, the support member 202 may be formed so that the distal wall retaining member 228 is of a different shape and/or size than the proximal wall retaining member 226.

[0067] The implants of Figures 5A-5G may use a balloon catheter or similar type device to deploy the tissue retention members. Alternatively, the wall retention members may deploy using spring-force or they may be self-actuating (e.g., a shape memory alloy, a super-elastic alloy, elastic deformation of a metal, etc.)

[0068] Figure 6 illustrates a variation of the implant 200 where the proximal and distal ends of the support member comprise wall retaining members 226 and 228. In this variation, the support member 202 comprises a grommet shaped implant. The support member 202 will be is flexible such that it may be deformed for deployment into the tissue

opening. The support member **202** may be made from a polymeric material (e.g., a molded polymer like silicone) or other deformable resilient material (e.g., a super-elastic alloy, etc.) This variation of the invention may be deployed by deforming the distal tissue retention member **226** to a reduced diameter which allows insertion of the implant **200** into the tissue opening. Once the mid portion **208** of the support member **202** is placed within the tissue opening, the restraints are removed from the support member **202**. The release of the constraints causes both the proximal and distal wall retention members **226** and **228** to return to their natural shape which secures the implant **200** about the wall. The implant support member **202** may have a continuous surface to prevent re-growth of tissue through the passage **230** or there may be various openings in the wall of the support member.

[0069] Figure 7A illustrates another variation of the implant **200** where the proximal and distal ends of the support member comprise wall retaining members **226** and **228**. In this variation the support member **202** comprises a sheet. The sheet may comprise a single material or may be a composite of different materials. The sides of the sheet comprise respective proximal and distal surfaces. An opening in the sheet comprises a passageway **230** of the implant **200**. The support member **202** also includes a plurality of wall retention members each individually formed from sections of the sheet about the perimeter of the sheet. Each retention member **226** and **228** is elastically deformable away from a plane of the sheet so that the device may be reduced in size (e.g., reduces an outer dimension of the sheet) for delivery of the implant into a tissue opening. When the support member **202** is placed within the tissue wall, the elasticity of the sheet-wall retention members returns the wall retention members to the plane of the sheet such that wall retention return to capture the airway wall.

[0070] Figure 7B illustrates a side view of the implant of Figure 7A. Figure 7C illustrates the implant of Figure 7B when deployed in an airway wall **100**. The support member **202** may be comprised from a polymeric sheet or a metallic material as described herein. Although depicted as circular, the outer profile of the sheet/support member **202** may be any shape (e.g., rectangular, elliptical, square, etc.) The implant **200** may have any number of tissue retaining members as needed.

[0071] The implant described herein may be manufactured by a variety of manufacturing processes including but not limited to laser cutting, chemical etching, punching, stamping, etc. For example, the implant may be formed from a tube that is slit to form extension members and a center section between the members. One variation of the implant may be constructed from a metal tube, such as stainless steel, 316L stainless steel,

titanium, tantalum, titanium alloy, nitinol, MP35N (a nickel-cobalt-chromium-molybdenum alloy), etc. Also, the implant may be formed from a rigid or elastomeric material that is formable into the configurations described herein. Also, the implant may be formed from a cylinder with the passageway being formed through the implant. The implant may also be formed from a sheet of material in which a specific pattern is cut. The cut sheet may then be rolled and formed into a tube. The materials used for the implant can be those described above as well as a polymeric material, a biostable or implantable material, a material with rigid properties, a material with elastomeric properties, or a combination thereof. If the implant is a polymeric elastic tube (e.g. a thermoplastic elastomer), the implant may be extruded and cut to size, injection molded, or otherwise formed.

[0072] Additionally, the implants described herein may be comprised of a shape memory alloy, a super-elastic alloy (e.g., a NiTi alloy), a shape memory polymer, or a shape memory composite material. The implant may be constructed to have a natural self-assuming deployed configuration, but is restrained in a pre-deployed configuration. As such, removal of the restraints (e.g., a sheath) causes the implant to assume the deployed configuration. A implant of this type could be, but is not limited to being, comprised from an elastic polymeric material, or shape memory material such as a shape memory alloy. It is also contemplated that the implant could comprise a shape memory alloy such that, upon reaching a particular temperature (e.g., 98.5 °F), it assumes a deployed configuration.

[0073] The implant's surface may be modified to affect tissue growth or adhesion. For example, an implant may comprise a smooth surface finish in the range of 0.1 micrometer to 0.01 micrometer. Such a finish may serve to prevent the implant from being ejected or occluded by tissue overgrowth. On the other hand, the surface may be roughened or porous. The implant may also comprise various coatings and polymeric layers as discussed below.

COMPOSITION

[0074] As discussed above, the implants of the present invention may include a composition or polymeric layer that includes a bio-active substance or combination of bioactive substances. In some cases, the implant itself may be formed from a polymeric composition or a polymer having the bio-active substance;. The purpose of the composition is to assists in modifying the healing response as a result of the trauma to lung tissue resulting from creation of the collateral channel. The term lung tissue is intended to

include the tissue lining the airway, the tissue beneath the lining, and the tissue within the lung but exterior to the airway (e.g., lung parenchyma.) In modifying the healing response it is fundamentally desirable to further the patency of the channel to allow sufficient flow of trapped gasses through the implant into the airways. A discussion of the bio-active substances is found below.

[0075] The composition may comprise a polymeric layer which acts as a carrier for various bioactive or other agents as described herein. Alternatively, or in combination, the polymeric layer may function as a tissue barrier to inhibit growth of tissue into the conduit/implant. In an additional variation, the support member may be fabricated from a polymeric material having the bio-active substance incorporated directly therein. The composition 212 prevents tissue in-growth from occluding the collateral channel or passage of the implant 200. The polymeric layer 212 may coaxially cover the center section from one end to the other or it may only cover one or more regions of the implant 200. The composition 212 may completely or partially cover the implant 200. The composition 212 may be located about an exterior of the implant's surface, about an interior of the implant's surface.

[0076] Alternatively, or in combination, as shown in Figure 8, the composition 212 may be located within an opening or pocket 220 in the support structure 202 of the implant. In such a case, the pocket 220 will have a barrier (e.g., polymeric or other porous material) that either degrades to allow the composition or bioactive substance to be delivered from the implant, or acts as a diffusible barrier to deliver the composition or bioactive substance.

[0077] The composition should be selected to accommodate the significant expansion of the implant. Examples of such polymers include, but are not limited to, thermoplastic polymers, thermoset polymers, acrylate polymers, a blend of acrylate-methacrylate polymers, silicone elastomers, urethane elastomers, ethylene vinyl acetate polymers, polyethylene, polypropylene, PLA-PGA, PLA, PGA, polyortho-ester, polycaprolactone, polyester, hydrogels, polystyrene, co-polymers of styrene-isobutylene-styrene, and combinations or blends thereof.

[0078] Examples of bioabsorbable polymers include but are not limited to poly(L-lactic acid), polycaprolactone, poly(lactide-co-glycolide), poly(hydroxybutyrate), poly(hydroxybutyrate-co-valerate), polydioxanone, polyorthoester, polyanhydride, poly(glycolic acid), poly(D,L-lactic acid), poly(glycolic acid-co-trimethylene carbonate), polyphosphoester, polyphosphoester urethane, poly(amino acids), cyanoacrylates, poly(trimethylene carbonate), poly(iminocarbonate), copoly(ether-esters) (e.g., PEO/PLA),

polyalkylene oxalates, polyphosphazenes and biomolecules such as fibrin, fibrinogen, cellulose, starch, collagen and hyaluronic acid. Also, biostable polymers with a relatively low chronic tissue response such as polyurethanes, silicones, fluorosilicones, and polyesters could be used. Also, hydrogels may be used to carry the drug.

[0079] Examples of other types of polymers that may be useful include but are not limited to polyolefins, polyisobutylene and ethylene-alphaolefin copolymers; acrylic polymers and copolymers, vinyl halide polymers and copolymers, such as polyvinyl chloride; polyvinyl ethers, such as polyvinyl methyl ether; polyvinylidene halides, such as polyvinylidene fluoride and polyvinylidene chloride; polyacrylonitrile, polyvinyl ketones; polyvinyl aromatics, such as polystyrene, polyvinyl esters, such as polyvinyl acetate; copolymers of vinyl monomers with each other and olefins, such as ethylene-methyl methacrylate copolymers, acrylonitrile-styrene copolymers, ABS resins, and ethylene-vinyl acetate copolymers; polyamides, such as Nylon 66 and polycaprolactam; alkyd resins, polycarbonates; polyoxymethylenes; polyimides; polyethers; epoxy resins, polyurethanes; rayon; rayon triacetate; cellulose, cellulose acetate, cellulose butyrate; cellulose acetate butyrate; cellophane; cellulose nitrate; cellulose propionate; cellulose ethers; and carboxymethyl cellulose. It may be possible to dissolve and cure (or polymerize) these polymers on the implant so that they do not leach into the tissue and cause any adverse effects on the tissue.

[0080] The coatings may be applied, for example, by either dip coating, molding, spin-coating, painting, transfer molding or liquid injection molding. Alternatively, the polymeric layer may be a tube of a material and the tube is placed either over and/or within the implant. The polymeric layer may then be bonded, crimped, heated, melted, shrink fitted or fused to the implant. The polymeric layer may also be tied to the implant with a filament of, for example, a suture material.

[0081] Still other techniques for attaching the polymeric layer include: solvent swelling applications and extrusion processes; wrapping a sheet of material about the implant, or placing a tube of the material about the implant and securing the tube to the implant. The polymeric layer may be secured on the interior of the implant by positioning a sheet or tube of material on the inside of the center section and securing the material therein.

[0082] The composition may also be formed of a fine mesh with a porosity or treatment such that tissue may not penetrate the pores. For example, a ChronoFlex™ DACRON® or TEFLON® mesh having a pore size of 100-300 microns may be saturated with collagen or another biocompatible substance. This construct may form a suitable polymeric layer. The

mesh may be coaxially attached to a frame such as the open frame structures disclosed above. Still other suitable frames include a continuous spiral metallic or polymeric element.

BIOACTIVE SUBSTANCES:

[0083] As discussed above, the bio-active substance or combination of bioactive substances is selected to assist in modifying the healing response as a result of the trauma to the lung tissue resulting from creation of the collateral channel. As noted above, the term lung tissue is intended to include the tissue lining the airway, the tissue beneath the lining, and the tissue within the lung but exterior to the airway (e.g., lung parenchyma.) The purpose of modifying the healing response is to further extend the patency of the channel or implant to increase the duration which trapped gasses may exit through the implant into the airways. The term antiproliferative agent is intended to include those bioactive substances that directly modify the healing response described herein.

[0084] The bioactive substances are intended to interact with the tissue of the surgically created channels and in particular, lung tissue. These substances may interact with the tissue in a number of ways. They may, for example, 1.) accelerate cell proliferation or wound healing to epithelialize or scar the walls of the surgically-created channel to maintain its patent shape or 2.) the substances may inhibit or halt tissue growth when a channel is surgically created through an airway wall such that occlusion of the channel due to tissue overgrowth is prevented. Additionally, other bioactive agents may inhibit wound healing such that the injury site (e.g., the channel or opening) does not heal leaving the injury site open and/or inhibit infection (e.g., reduce bacteria) such that excessive wound healing does not occur which may lead to excessive tissue growth at the channel thereby blocking the passageway.

[0085] A variety of bioactive substances may be used alone or in combination with the devices described herein. Examples of bioactive substances include, but are not limited to, antimetabolites, antithrobotics, anticoagulants, antiplatelet agents, thrombolytics, antiproliferatives, antiinflammatories, agents that inhibit hyperplasia and in particular restenosis, smooth muscle cell inhibitors, growth factors, growth factor inhibitors, cell adhesion inhibitors, cell adhesion promoters and drugs that may enhance the formation of healthy neointimal tissue, including endothelial cell regeneration. The positive action may come from inhibiting particular cells (e.g., smooth muscle cells) or tissue formation (e.g., fibromuscular tissue) while encouraging different cell migration (e.g., endothelium, epithelium) and tissue formation (neointimal tissue).

[0086] Still other bioactive agents include but are not limited to analgesics, anticonvulsives, anti-infectives (e.g., antibiotics, antimicrobials), antineoplastics, H2 antagonists (Histamine 2 antagonists), steroids, non-steroidal anti-inflammatories, hormones, immunomodulators, mast cell stabilizers, nucleoside analogues, respiratory agents, antihypertensives, antihistamines, ACE inhibitors, cell growth factors, nerve growth factors, anti-angiogenic agents or angiogenesis inhibitors (e.g., endostatins or angiostatins), tissue irritants (e.g., a compound comprising talc), poisons (e.g., arsenic), cytotoxic agents (e.g., a compound that can cause cell death), various metals (silver, aluminum, zinc, platinum, arsenic, etc.), epithelial growth factors or a combination of any of the agents disclosed herein.

[0087] Examples of agents include pyrolytic carbon, titanium-nitride-oxide, taxanes, fibrinogen, collagen, thrombin, phosphorylcholine, heparin, rapamycin, radioactive 188Re and 32P, silver nitrate, dactinomycin, sirolimus, everolimus, Abt-578, tacrolimus, camptothecin, etoposide, vincristine, mitomycin, fluorouracil, or cell adhesion peptides. Taxanes include, for example, paclitaxel, 10-deacetyltaxol, 7-epi-10-deacetyltaxol, 7-xylosyl-10-deacetyltaxol, 7-epi-taxol, cephalomannine, baccatin III, baccatin V, 10-deacetylbaccatin III, 7-epi-10-deacetylbaccatin III, docetaxel.

[0088] Of course, bioactive materials having other functions can also be successfully delivered in accordance with the present invention. For example, an antiproliferative agent such as methotrexate will inhibit over-proliferation of smooth muscle cells and thus inhibit restenosis. The antiproliferative is desirably supplied for this purpose until the tissue has properly healed. Additionally, localized delivery of an antiproliferative agent is also useful for the treatment of a variety of malignant conditions characterized by highly vascular growth. In such cases, an implant such as a implant could be placed in the surgically created channel to provide a means of delivering a relatively high dose of the antiproliferative agent directly to the target area. A vasodilator such as a calcium channel blocker or a nitrate may also be delivered to the target site. The agent may further be a curative, a pre-operative debulker reducing the size of the growth, or a palliative which eases the symptoms of the disease. For example, tamoxifen citrate, Taxol[®] or derivatives thereof Proscar[®], Hytrin[®], or Eulexin[®] may be applied to the target site as described herein.

[0089] Variations of the invention may also include fibrinolytics such as tPA, streptokinase, or urokinase, etc. Such fibrinolytics prevent or reduce the accumulation of fibrin within the opening. Accumulation of fibrin in the opening may result from inflammation of the tissue. The fibrin may form a structure which makes it easier for tissue

to grow into the opening using the fibrin structure as a framework. Use of fibrinolytics, either topically, locally, or on the implant, serves to remove or hinder the network of fibrin from forming within the opening (or implant) and therefore aids in modifying the healing response.

[0090] In the event that poisonous and toxic compounds are delivered, they should be controlled to avoid substantial cytotoxicity so that inadvertent death of tissue does not occur, pneumothorax, unacceptable systemic levels, etc.. The poisonous agent should be delivered locally or only be effective locally. One method for delivering the bioactive agent locally is to associate the bioactive agent with an implant. For example, the implants described herein may include a bioactive substance or medicine deposited onto the interior, the exterior, or both the interior and exterior surfaces of the implant. The bioactive substance may remain on the implant so that it does not leach. Cells that grow into the surgically created channel contact the poison and die. Alternatively, the bioactive agent may be configured to gradually elute as discussed below.

[0091] When used in the lungs, the implant modifies the healing response of the lung tissue (e.g., at the site of newly created hole/channel) for a sufficient time until the healing response of the lung tissue subsides or reduces such that the hole/channel becomes a persistent air path. For example, the implant and bioactive substance will modify the healing response for a sufficient time until the healing response is reduced and, from a visual observation, the body treats the opening essentially as a natural airway passage rather than as an injury to the airway wall.

[0092] To illustrate the above, Figures 10A-10B show histology from animal models. The histology is a cross sectional slice of the airway wall **110** and lung parenchyma **116**. In each slide, the collateral channel **112** was created in the airway wall **110** and extended into the lung parenchyma **116**. The implant (which was removed for histology and is not shown) was placed in the channel **112** so as to create an airflow path (as demonstrated by the arrows **114**) from the lung parenchyma **116** through the airway wall **110**.

[0093] Figure 10A illustrates a histology sample from a site two weeks subsequent to the creation of a channel and implantation with a device. In this site, the device included a polymeric coating but no bio-active substance. This site was also given a single local treatment of a bioactive substance (mitomycin) subsequent to creation of the channel **112**. As shown, two weeks subsequent to the procedure, the healing process of the lung tissue already caused a considerable amount of fibrosis **120** between the channel **112** and lung parenchyma **116**. From the figure, the fibrosis appears as a darker tissue that is adjacent to

the lung parenchyma 116. The presence of this fibrosis 120 strongly suggests that air would not be able to flow from the lung parenchyma 116 through the channel 112.

[0094] Figure 10B illustrates a histology sample from a site 18 weeks subsequent to the creation of a channel and implantation with an implant of the present invention (an example of which is discussed below.) As evident from the figure, the channel 112 remained significantly unobstructed with only a minimal discontinuous layer of fibrosis 120.

[0095] In one variation of the invention which modifies the healing response as describe above, the implant provides a steady release rate of bio-active substance as well as has a sufficient amount of available bio-active substance to modify the healing response of the lung tissue. As noted herein, the term lung tissue is intended to include the tissue lining the airway, the tissue beneath the lining, and the tissue within the lung but exterior to the airway (e.g., lung parenchyma.) Such a delivery profile allows for a concentration gradient of drug to build in these tissues adjacent to the delivery site of the implant.

[0096] It is believed that forming the concentration gradient affects the healing response of the lung tissue so that the implant does not become occluded as a result of the healing response. Because the implant is often placed in the airway wall it is exposed to the healing process of the multiple tissues. Providing a sufficient amount of bio-active substance allows for the formation of a concentration of the bio-active substance across these various tissues. In one variation of the invention it is believed that the fluids from these tissues enter into the composition layer of the device. The fluids then combine with the bio-active substances and migrate out of the composition layer to settle into the lung tissue. A concentration gradient forms when the drug 'saturates' local tissue and migrates beyond the saturated tissues. Furthermore, by providing a sufficient delivery rate, the healing response may be affected or suppressed during the critical time immediately after the wounding caused by creation of the collateral channel when the healing response is greatest.

[0097] To select a proper combination of drug and polymer, it is believed that the solubility parameter of the polymer must be matched with the bio-active substance to provide an acceptable slow elution rate from the polymer. Next, the polymer itself must be selected to have the proper attributes, such as a proper diffusion coefficient (to slow fluid entering and departing from the implant), and proper mechanical expansion properties (to allow for the significant expansion of the polymer to accommodate formation of the grommet shape.)

[0098] The solubility parameter is defined as the square root of the cohesive energy of the molecules in a compound. The level of control that a polymer has over the elution of a drug is the difference between the solubility parameters of the polymer and the solubility parameter of the drug. To select a polymer with the approximate diffusion a polymer with a high internal density could be selected to be less permeable to a complex molecule such as paclitaxel. Using a polymer with high internal density also accommodated the significant expansion required of the polymer to form the structure necessary to grommet about the airway wall. An example of the polymer selection is found below.

[0100] It is also important to note that paclitaxel is a taxane that is regarded as a microtubule stabilizer. The benefits of a microtubule stabilizing substance for use in vascular drug eluting stents is discussed, for example, in U.S. Patent No. 5,616,608 to Kinsella et al. This type of drug operates to enhance microtubule polymerization which inhibits cell replication by stabilizing microtubules in spindles which block cell division. In contrast to the vascular applications, the implant for use in the present invention may use microtubule stabilizing substances such as taxanes (e.g., paclitaxel) as well as those microtubule destabilizing substances that are believed to promote microtubule disassembly in preventing cell replication. Such destabilizing substances include, but are not limited to vincristine, vinblastine, podophylotoxin, estramustine, noscapine, griseofulvin, dicoumarol, a vinca alkaloid, and a combination thereof.

[0101] Additionally, the exterior surface of the implant may be treated via etching processes or with electrical charge to encourage binding of the bioactive substances to the implant. The exterior surface may also be roughened to enhance binding of the medicine to the surface as discussed in U.S. Patent Application Publication No. 2002/0098278. *See also* U.S. Patent Application Publication Nos. 2002/0071902, 2002/0127327 and U.S. Patent No. 5,824,048 which discuss various techniques for coating medical implants.

[0102] Although the implant may comprise a frame or body with a bioactive matrix disposed or otherwise associated therewith, the invention is not so limited. In one variation, the support member is formed from a polymer and the composition is joined to the polymeric support member. Alternatively, the bioactive substances may be placed directly onto the polymeric support member.

[0103] Various additional substances may be used incorporated into the device to reduce an adverse reaction resulting from possible contact with the implant and the airway wall. Adverse reactions include, but are not limited to, granulation, swelling, and mucus overproduction. These substance may may also be inhaled, injected, orally applied,

topically applied, or carried by the implant. These substances may include anti-inflammatory, infection-fighting substances, steroids, mucalytics, enzymes, and wound healing-accelerating substances. Examples of these substances include but are not limited to, acetylcysteine, albuterol sulfate, ipratropium bromide, dornase alfa, and corticosteroids.

[0104] As noted above, conventional vascular drug eluting devices are not designed for exposure multiple tissue environments. Moreover, those devices are placed in an environment where a constant flow of blood creates an environment requiring a different delivery mechanism and rate. As noted herein, experiments with conventional coronary drug eluting implants demonstrated that such devices were unsuitable.

[0105] Figure 11 illustrates data from a pre-clinical animal model evaluating the wound healing response, under pre-clinical protocol (QT-305), using an implant w/o any antiproliferative substance, a paclitaxel coronary Stent (manufactured by Boston Scientific under the name Taxus®), and a sirolimus coronary stent (manufactured by Johnson & Johnson under the name Cypher®). In comparison, experiments using implants according to the present invention, QT-345 and QT-362 were conducted. The implant w/o any antiproliferative substance, the paclitaxel coronary stent, and the sirolimus coronary stent reduced to at least 50% patency without stabilization (i.e., the determination was made that 100% closure would occur.) The chart indicates closure of these devices given a criteria that at least half of the implanted devices closed with tissue and the trend indicated that full closure of the devices would occur. In contrast, the implants according to the present invention maintained 88% patency of the openings @ 12 weeks (QT-362) and 69% patency @ 18 weeks (QT-345). In both of these latter cases, repeated inspection determined that the healing response (as evidenced by the closure rate) of the implants stabilized. Furthermore, for QT-362, 2 specimens maintained 100% patency while 1 specimen maintained 75% patency. For QT-345, no decline in patency occurred for the last 6 weeks of the trial.

[0106] It is important to note that, to obtain data and histology, applicants terminated QT-304 at 7 weeks (42 days), QT-362 at 12 weeks, and QT-345 at 18 weeks. Yet, based on the trend and closure of the devices, full closure would have occurred soon after 7 weeks for all devices in QT-304. In contrast, based on the stabilization of both the trend and relative patency of the devices in QT-362 and QT-345, patency of the devices in these trials would have extended well beyond the respective 12 and 18 weeks. In the above protocols, patency of the implants were determined visually using a bronchoscope advanced to the implant site.

VISUALIZATION FEATURE

[0107] As discussed above, when placed into an airway wall, the implant of the present invention is usually placed using a bronchoscope under direct visualization. In such a procedure, the direct visualization only permits viewing of the interior of the airway and care must be taken to place the implant such that during expansion, the implant properly deploys about the airway wall. Also, care must be taken not to advance the implant/delivery catheter too far into the opening into the airway wall. Improper advancing of the implant/delivery catheter could potentially result in a pneumothorax.

[0108] To address the above problem, as illustrated in previous figures, the implant **200** may also include a visualization mark **218**. The visualization marker **218** is visually apparent during a procedure and gives the medical practitioner an indication when the implant/delivery catheter is advanced to the proper location. In this manner, the visualization mark **218** facilitates alignment and deployment of the implants into collateral channels.

[0109] The visualization mark **218** may be a ring of biocompatible polymer and may be selected to provide contrast so that it may be identified as the medical practitioner views the device through an endoscope or bronchoscope. For example, the bronchoscope will usually contain a light-source that illuminates the target area. Therefore, the visualization mark may be something that reflects or refracts the light in a different manner from the remainder of the implant. In one variation, the visualization mark may be the same color as the remainder of the device, or partially transparent, or entirely transparent, but is identifiable because the mark reflects or refracts light differently than the remainder of the device. Also, the visualization feature may protrude from the center section or it may be an indentation(s). The visualization mark may also be a ring, groove or any other physical feature on the implant. Moreover, the visualization feature may be continuous or comprise discrete segments (e.g., dots or line segments).

[0110] The visualization feature may be made using a number of techniques. In one example, the mark is a ring formed of silicone and is white. The polymeric ring may be spun onto the polymeric layer. For example, a clear silicone barrier may be coated onto the implant such that it coaxially covers the implant. Next, a thin ring of white material such as a metal oxide suspended in clear silicone may be spun onto the silicone coating. Finally, another coating of clear silicone may be applied to coat the white layer. The implant thus may include upwards of 1-3 layers including a polymeric layer, a visualization mark layer, and a clear outer covering. In another example the mark is a ring formed of silicone and is

black. In another example the mark is a ring formed by suspending gold particulates in the polymer as shown in Figure 9A.

[0111] The shape of the visualization mark is not limited to a thin ring. The visualization mark may be large, for example, and cover an entire half of the implant as shown in Figure 9B. The visualization mark may, for example, be a white coating disposed on the proximal or distal half of the implant. The visualization mark thus may extend from an end of the extension members to the center section of the implant. As explained in more detail below, when such a device is deposited into a channel created in lung tissue, the physician may observe when one-half of the implant extends into the channel. This allows the physician to properly actuate or deploy the implant to secure the implant in the tissue wall.

[0112] In most variations of the invention, the visualization mark is made to stand out when viewed with, for example, an endoscope. The implants may also have additional imaging enhancing additives to increase non-direct imaging, such as fluoroscopic or radiosopic viewing. It is also contemplated that other elements of the implant can include visualization features such as but not limited to the extension members, polymeric layer, control segments, etc.

[0113] In some variations of the invention, it was found that incorporation of a bioactive or other substance into the coating caused a coloration effect in the composition layer (e.g., the polymer turns white). This coloration obscures the support member structure in the layer making it difficult to identify the edges and center of the support member or implant. As discussed herein, placement of the implant may depend upon positioning the center of the implant within the opening in tissue. If the support member structure is identifiable, then one is able to visually identify the center of the implant. When the composition colors obscures the support member or renders the implant otherwise opaque, it may become difficult to properly place the device. This may be especially true when the composition layer extends continuously over the support member.

[0114] Additionally, the coloration may render the visualization mark difficult to identify especially under direct visualization (e.g., using a scope) In some cases it was undesirable to simply add additional substances on or in the composition layer for marking because such substances could possibly interfere with the implant's ability to deliver the substance as desired. To address these issues, a variation of the invention includes a delivery device for delivering an the implant (such as those described herein and in the cases referenced herein), where the delivery device and the implant are of different visually

identifiable colors or shades such that their distinction is easy to identify under endoscopic or bronchoscopic viewing. Such a feature permits identification of the proximal end of implant and assists in preventing too much advancement of the implant into the tissue beyond the airway wall.

[0115] In one example, as shown in Figure 9C, a delivery catheter **300** has a colored sleeve **306** located adjacent or underneath the implant **200**. The sleeve **306** comprises a visually identifiable color where selection of the colors should ease identification of the implant in an endoscopic visualization system (e.g., blue or a similar color that is not naturally occurring within the body.) The implant is placed about the sleeve **306** where the proximal and distal areas of the implant would be identifiable by the difference in color. Such a system allows a medical practitioner to place the implant **200** properly by using the boundary of the implant **200** to guide placement in the tissue wall. The sleeve **306** may be fashioned from any expandable material, such as a polymer.

[0116] In another variation, the visualization mark may comprise providing a contrast between the implant and a delivery catheter. In one example because the implant appears mostly white and is mounted on a delivery catheter, it is difficult to identify the location of implant under visualization. In this example the implant would be placed over a blue colored catheter. The proximal and distal areas of the implant would be flanked by the blue color, thus giving the appearance of a distinct distal and proximal end of the implant. This would allow a physician to place the implant properly by using the blue flanks as a guide for placing the central white portion in the tissue wall. Similarly, a colored flexible sheath covering the catheter would also suffice.

[0117] It is noted that while the visualization features described above are suitable for use with the implants described herein, the inventive features are not limited as such. The features may be incorporated into any system where placement of an implant under direct visualization requires clear identification of the implant regardless of whether the implant is opaque or colored.

VALVES AND BARRIERS WITHIN IMPLANTS

[0118] The implants may further comprise various structures deposited within the passageway. For example, as shown in Figure 3C, an implant may include a valve **224**. The valve **224** may be positioned such that it permits expiration of gas from lung tissue but prevents gas from entering the tissue. The valve **224** may be placed anywhere within the passageway of the implant. The valve **224** may also be used as bacterial in-flow protection for the lungs. The valve **224** may also be used in combination with a bioactive or biostable

polymeric layer/matrix and the polymeric layer may be disposed coaxially about the implant. Various types of one way valves may be used as is known to those of skill in the art.

[0119] One example of the one-way valve 224 is a valve as shown in Figure 3C. The geometry of the valve is such that when air is passed through the valve 224 the bill members deflect. When air places pressure on the closed side the geometry of the bills place a force onto the opening preventing air from flowing through.

[0120] Additionally, a valve could be used to prevent fluid such as mucus from flowing into the passage and into the parenchyma. Such a valve could be configured and could operate similarly to the one described above for gas flow.

[0121] The above illustrations are examples of the invention described herein. Because of the scope of the invention, it is specifically contemplated that combinations of aspects of specific embodiments or combinations of the specific embodiments themselves are within the scope of this disclosure.

EXAMPLE – Implant

[0122] Implants comprising stainless steel mesh frame fully encapsulated with a composition comprising silicone (as described below) and paclitaxel were implanted in several canine models. Visual observation indicated that, on average, the passage through the implants of the present invention remained unobstructed and were associated with significantly reduced fibrotic and inflammatory responses, in canine models, at a considerably higher rate than an implant without any drug adjunct or coronary drug eluting stents (as shown in Figure 11).

[0123] The composition comprised approximately a 9% paclitaxel to silicone ratio with approximately 400 micrograms of paclitaxel per implant. Measurements found that approximately 30% of the paclitaxel released after 60 days. In general, for implants with the paclitaxel/silicone composition, observations of chronic inflammation, epithelial metaplasia and fibrosis were all very mild.

[0124] For paclitaxel as the bioactive substance, polymers with solubility parameters between 5 - 25 (MPa)^{1/2} were believed to provide sufficient elution rates. The polymer used in the example device has good diffusivity for lipophilic drug (such as paclitaxel) because the side methyl group on the silicone may be substituted with more lipophilic hydrocarbon molecules containing vinyl group or groups for polymerization by platinum catalyst.

[0125] Some variations of the invention include an active analog and/or derivative of paclitaxel in addition to the paclitaxel. Such variation may have a ratio of the first amount of paclitaxel to the second amount of the active derivative or analog of paclitaxel comprises of at least 2 to 1, 3 to 1 or other ranges as found necessary to assist in maintaining patency of the implant passageway. The amounts of paclitaxel may be as provided herein or include additional ranges.

[0126] Accordingly, a variation of the invention includes an implant with a composition located on the support member and comprising an antiproliferative agent, where the agent comprises a first amount of paclitaxel and a second amount of an active derivative or analog of paclitaxel. One example of such an active derivative or analog of paclitaxel may be 7-epitaxol. It is believed that existence of the 7-epitaxol aids in maintaining the patency of the implant passageway.

[0127] The process of polymerizing two (2) parts, part A and part B, of Med 6640 silicone, created the 7-epitaxol from the paclitaxel. The epimerization occurs at the number seven (7) carbon from an S enantiomer to an R enantiomer. The conversion takes place when the temperature is raised from 75°C to 150°C.

[0128] It is not exactly known if the production of 7-epitaxol arises from heat alone or whether other reactant components are necessary. The components that are active during this process are: a) paclitaxel; b) heat (150°C); c) heat (75°C then 150°C); d) initiator (Pt°); e) proton radicals of – Pt°, vinyl-silicone; f) xylene; g) dichloromethane; given a certain time parameter.

[0129] It may be that the production of 7-epitaxol from paclitaxel only requires heat. It may require that all the components be in the exact order and quantity to produce 7-epitaxol from PTX. Some combinations or some key components and time are all that are required to produce 7-epitaxol from PTX. To understand the exact parameters to produce 7-epitaxol from PTX requires more care studies.

[0130] In one variation of the device, where the loading was approximately 6%, it was found that (while the theoretical paclitaxel load per implant was approximately 300µg) extraction studies of the implant indicated that the actual load of the implant comprised around 250µg of paclitaxel along with 45µg of 7-epitaxol. In this case there was 20µg of drug that was unaccounted. This latter unaccounted amount is generally referred to the bound polymer or bound fraction.

[0131] The bound-fraction (i.e., the portion of unaccounted drug discussed above) varies and is not proportion to the percent drug load. Bound-fractions are typical

occurrences in matrix-drug-delivery devices. The amount of bound-fraction varies depending upon chemistry of the polymerization reaction stoichiometry and the characteristics of the drug.

[0132] In another example of the device, where the loading was approximately 7%, the theoretical paclitaxel load per implant was approximately 350 μ g, while extraction studies of the implant indicated that the actual load of the implant comprised around 290 μ g of paclitaxel along with 45 μ g of 7-epitaxol. In this case the bound fraction was 15 μ g.

[0133] In another example of the device where the loading was approximately 12%, the theoretical paclitaxel load per implant was approximately 670 μ g and extraction studies of the implant indicated that the actual load of the implant comprised around 490 μ g of paclitaxel along with 100 μ g of 7-epitaxol. In this case the bound fraction was 80 μ g.

[0134] In yet another example of the device where the loading was approximately 9%, the theoretical paclitaxel load per implant was approximately 400 μ g and extraction studies of the implant indicated that the actual load of the implant comprised around 300 μ g of paclitaxel along with 50 μ g of 7-epitaxol. In this case the bound fraction was 50 μ g.

[0135] It should be noted that the ratio as well as the total load may be adjusted as the application requires to modify the release characteristics. For example, an implant coated with polymer loaded with relatively high percentage of paclitaxel can have a relatively low total drug load by decreasing the amount of polymer/drug coating.

[0136] In variations of the implant, the composition may be as follow: polymer part: polydimethylsiloxane, vinyl dimethyl terminated, any viscosity; and/or polydimethylsiloxane, vinyl monomethyl terminated, any viscosity. The cross-linker part: polydimethylsiloxane, any viscosity; and/or poly monomethylsiloxane, any viscosity. Platinum catalyst part and/or cross-linker part: platinum; and/or platinum-divinyltetramethyldisiloxane complex in xylene, 2-3% Pt; and/or platinum-divinyltetramethyldisiloxane complex in vinyl terminated polydimethylsiloxane, 2-3% Pt; and/or platinum-divinyltetramethyldisiloxane complex in vinyl terminated polydimethylsiloxane, ~1% Pt; platinum-Cyclovinylmethylsiloxane complex, 2-3% Pt in cyclic vinyl methyl siloxane.

[0137] These components may be combined in different ratios to make the polymer. The hydrocarbon side chain off the silicone back bone makes this polymer system unique and may result in a "zero-order"-like release profile. The amount of vinyl siloxane cross-linker may determine the rate of the drug release and diffusivity of the polymer to the drug. There are other types of polydimethylsiloxanes such as: trimethylsiloxy terminated

polydimethylsiloxane in various viscosities, (48-96%) dimethyl (4-52%) diphenylsiloxane copolymer in various viscosities, dimethylsiloxane-ethylene oxide copolymer, dimethyl diphenylsiloxane copolymer, polymethylhydrosiloxane, trimethylsilyl terminated at various viscosities, (30-55%) methyl- (45-70%) dimethylsiloxane copolymer at various viscosities, polymethylphenylsiloxane, polydimethylsiloxane silanol terminated at various viscosities, polydimethylsiloxane aminopropyl dimethyl terminated at various viscosities. For paclitaxel a release profile was found to be acceptable with a polymer system consisting of polydimethylsiloxane vinyl terminated at various viscosity and a range of platinum-mono, di, tri and/or tetramethyldisiloxane complex.

We Claim:

1. An implant comprising
a support member;
an antiproliferative agent carried by the support member and having an amount that does not exhibit substantial cytotoxicity but controls the healing response by suppressing hyperplasia of lung tissue, to *maintain* patency of an artificial opening in the airway which allows for maintaining air passage between the opening and parenchyma for a sufficient time until the healing response of the lung tissue subsides such that the opening essentially becomes a natural airway passage; and
where the antiproliferative agent comprises a first amount of paclitaxel and a second amount of a derivative or analog of paclitaxel.
2. The implant of claim 1, comprising an amount of antiproliferative substance carried by the support member where the support member releases the antiproliferative substance at a pre-determined release rate, where the amount of antiproliferative substance and the release rate are sufficient to modify a healing response of the airway wall resulting from creation of the opening.
3. The implant of claim 1, where the support member is constructed from a polymer.
4. The implant of claim 3, where the polymer is selected from a group consisting of thermoplastic polymers, thermoset polymers, acrylate polymers, a blend of acrylate-methacrylate polymers, silicone elastomers, urethane elastomers, ethylene vinyl acetate polymers, polyethylene, polypropylene, PLA-PGA, PLA, PGA, polyortho-ester, polycaprolactone, polyester, hydrogels, polystyrene, co-polymers of styrene-isobutylene-styrene, and combinations or blends thereof.
5. The implant of claim 1, where the antiproliferative substance is carried within the polymeric material.
6. The implant of claim 1, where the distal portion and proximal wall retaining members are tapered and have a slope that increases towards the mid-portion.
7. The implant of claim 3, where the polymeric material comprises a bioabsorbable material

8. The implant of claim 1, where support member comprises a metallic frame having a polymer attached thereto.
9. The implant of claim 8, where the polymer fully encapsulates an interior surface of the frame.
10. The implant of claim 1, where the support member is non-expandable.
11. The implant of claim 1, where the distal portion and proximal portions are expandable to a greater diameter than the mid portion.
12. The implant of claim 1, where the support member comprises a ceramic material.
13. The implant of claim 12, where the distal portion and proximal portion have a greater diameter than the mid portion.
14. The implant of claim 1, where the distal and proximal portions have a distal and proximal end respectively, where the distal and proximal ends are blunt or rounded.
15. The implant of claim 1, where the support member has at least one pocket where the antiproliferative substance is located in the pocket, and further comprising a polymer at least covering the pocket to act as a barrier to release.
16. The implant of claim 1, where a ratio of the first amount of paclitaxel to the second amount of the derivative or analog of paclitaxel comprises at least 3 to 1.
17. The implant of claim 16, where first amount of paclitaxel comprises at least 200 micrograms.
18. The implant of claim 16, where the second amount of the derivative or analog of paclitaxel comprises at least 50 micrograms.
19. 19. The implant of claim 1, where the derivative or analog of paclitaxel comprises 7-epitaxol. The implant of claim 1, where the antiproliferative substance comprises a substance selected from the group consisting of steroids, non-steroidal anti-inflammatories, and d-actinomycin.
20. The implant of claim 1,, further including a mucus affecting substance.

21. The implant of claim 20, where the mucus affecting substance is selected from a group consisting of mucolytics, pulmozyme, and a combination thereof.
22. The implant of claim 1, where the antiproliferative substance comprises a fibrinolytic.
23. The implant of claim 1, further comprising at least one visualization mark disposed on a portion of the support member.
24. The implant of claim 23, where the visualization mark comprises a stripe circumferentially disposed about at least a portion the support member.
25. The implant of claim 1, further comprising a valve in fluid communication with the passageway.
26. The implant of claim 1, further comprising an antibiotic substance carried on or within the support member.

27. An implant for maintaining an opening in an airway wall comprising:
a non-expandable conduit having a first and second ends and a body therebetween, the conduit also comprising a passageway extending between the first and second ends;
at least two wall retaining portions on an exterior surface of the conduit and separated by a first body section, where the wall retaining portions have a diameter greater than the first body section;
a first bio-active material carried by at least the first body section, where the first bio-active material comprises a first amount of paclitaxel and a second amount of a derivative or analog of paclitaxel..
28. The implant of claim 27, further comprising a second body section extending away from a first end of the body, where at least one wall retaining portion is located between the first and second body sections.
29. The implant of claim 27, wherein at least one of the wall retaining portions is located near the first end and is tapered in an increasing direction away from the first end.
30. The implant of claim 27, wherein at least a second wall retaining portions is located near the second end and is tapered in an increasing direction away from the second end.
31. The implant of claim 27, further comprising a one way valve.
32. The implant of claim 27, where the non-expandable conduit is constructed from a polymer.
33. The implant of claim 32, where the polymer is selected from a group consisting of thermoplastic polymers, thermoset polymers, acrylate polymers, a blend of acrylate-methacrylate polymers, silicone elastomers, urethane elastomers, ethylene vinyl acetate polymers, polyethylene, polypropylene, PLA-PGA, PLA, PGA, polyortho-ester, polycapralactone, polyester, hydrogels, polystyrene, co-polymers of styrene-isobutylene-styrene, and combinations or blends thereof.
34. The implant of claim 27, where the first bio-active material is carried within a polymeric material.
35. The implant of claim 34, where the polymeric material comprises a bioabsorbable material

36. The implant of claim 27, where the non-expandable conduit comprises a metallic frame having a polymer attached thereto.
37. The implant of claim 36, where the polymer fully encapsulates an interior surface of the frame.
38. The implant of claim 27, where the non-expandable conduit comprises a ceramic material.
39. The implant of claim 38, where the first and second body ends have a greater diameter than the mid portion.
40. The implant of claim 27, where the first and second body ends have a distal and proximal end respectively, where the distal and proximal ends are blunt or rounded.
41. The implant of claim 27, where a ratio of the first amount of paclitaxel to the second amount of the derivative or analog of paclitaxel comprises at least 3 to 1.
42. The implant of claim 41, where first amount of paclitaxel comprises at least 200 micrograms.
43. The implant of claim 41, where the second amount of the derivative or analog of paclitaxel comprises at least 50 micrograms.
44. 44. The implant of claim 27, where the derivative or analog of paclitaxel comprises 7-epitaxol. The implant of claim 27, where the antiproliferative substance comprises a substance selected from the group consisting of steroids, non-steroidal anti-inflammatories, and d-actinomycin.
45. The implant of claim 27, further including a mucus affecting substance.
46. The implant of claim 45, where the mucus affecting substance is selected from a group consisting of mucolytics, pulmozyme, and a combination thereof.
47. The implant of claim 27, where the antiproliferative substance comprises a fibrinolytic.
48. The implant of claim 27, further comprising at least one visualization mark disposed on a portion of the non-expandable conduit.

49. The implant of claim 27, where the visualization mark comprises a stripe circumferentially disposed about at least a portion the support member.
50. The implant of claim 27, further comprising a valve in fluid communication with the passageway.
51. The implant of claim 27, further comprising an antibiotic substance carried on or within the support member.
52. An implant for maintaining an opening in a wall of an airway, the implant comprising a support member having a proximal portion, a distal portion, a mid portion and an interior passage extending therethrough;
an amount of antiproliferative substance carried by the support member where the support member releases the antiproliferative substance at a pre-determined release rate, where the amount of antiproliferative substance and the release rate are sufficient to modify a healing response of the airway wall resulting from creation of the opening, where the antiproliferative substance comprises a first amount of paclitaxel and a second amount of 7-epitaxol.

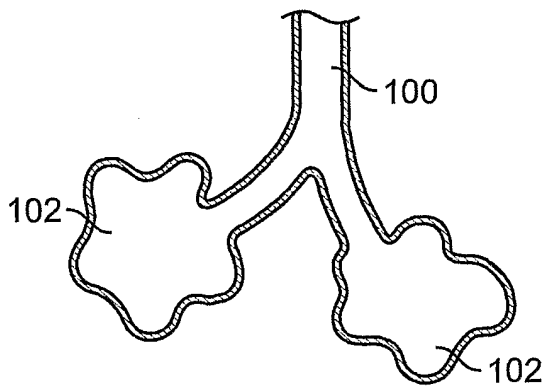

FIG. 1A

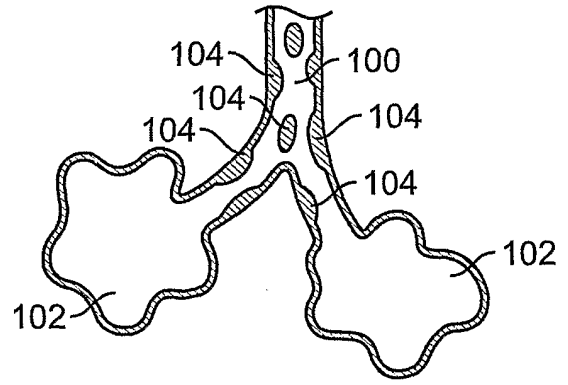

FIG. 1B

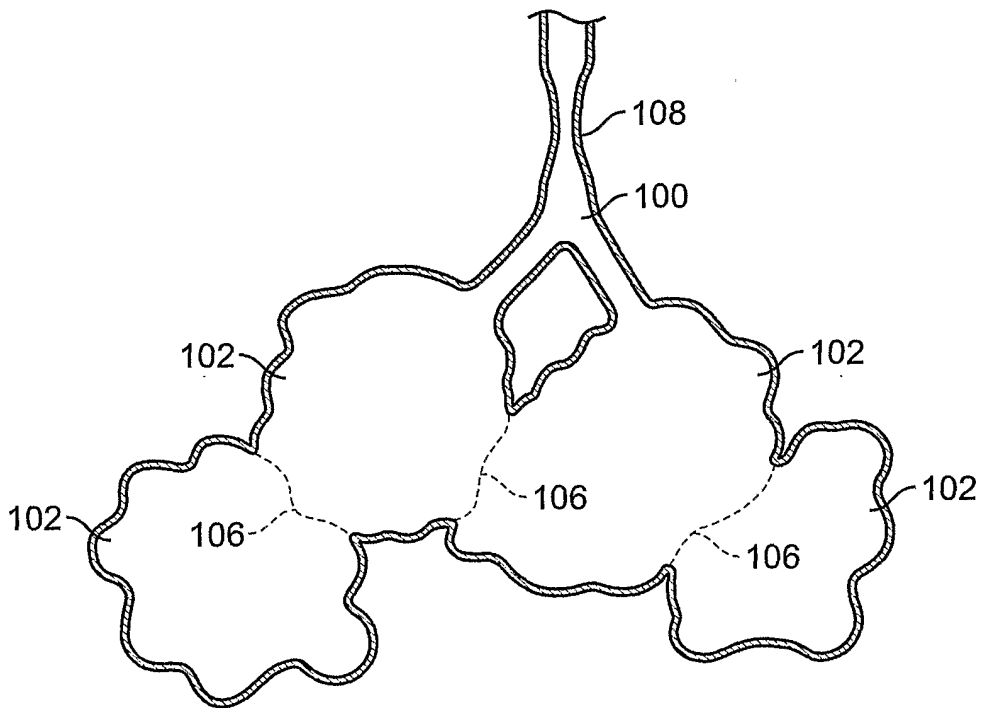

FIG. 1C

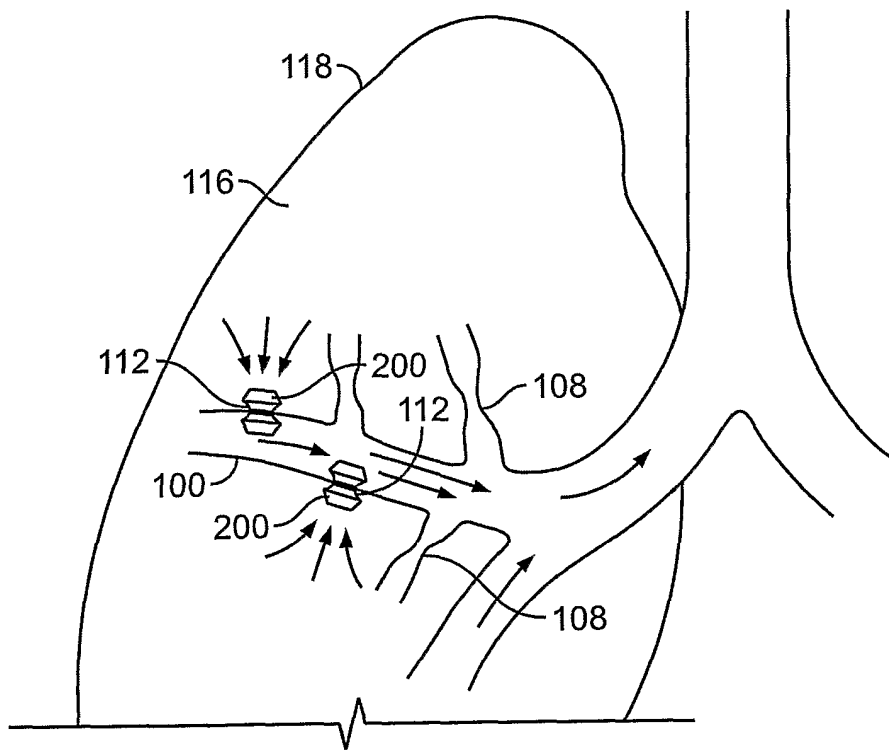

FIG. 1D

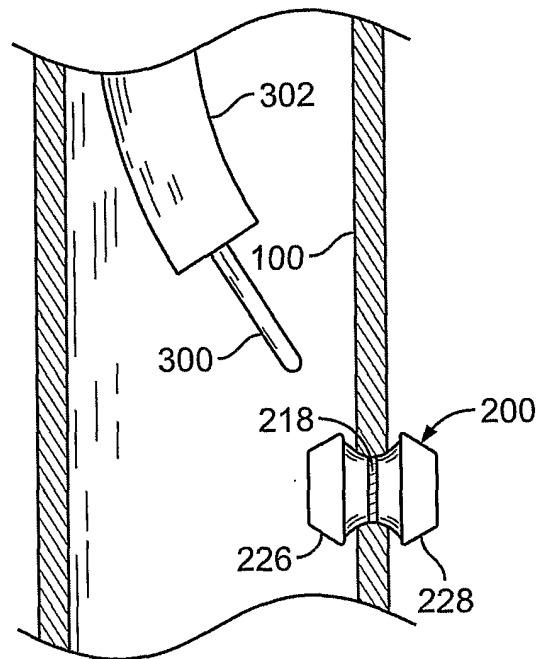

FIG. 2A

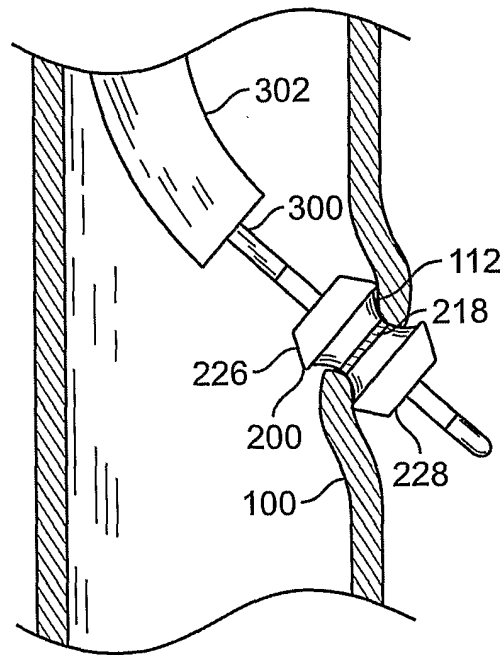

FIG. 2B

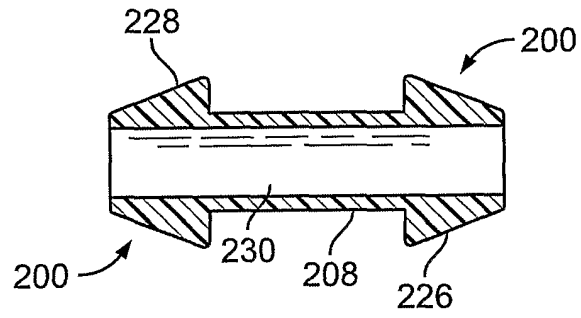

FIG. 3A

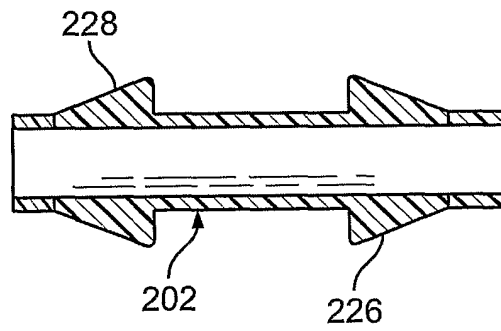

FIG. 3B

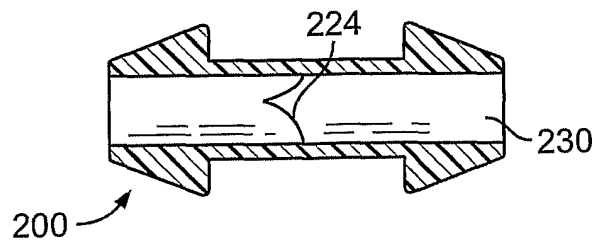

FIG. 3C

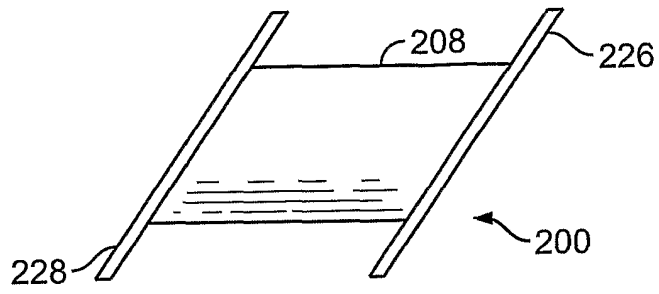

FIG. 4A

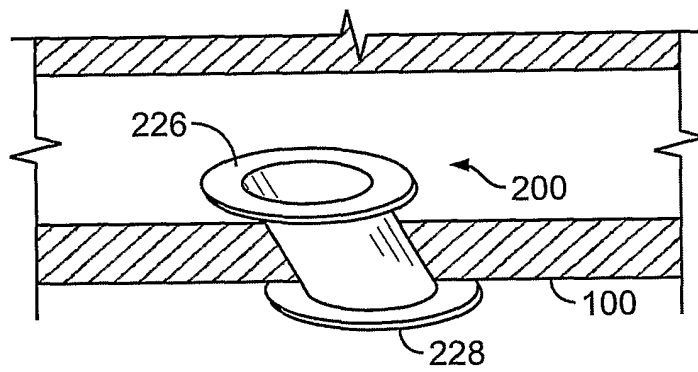

FIG. 4B

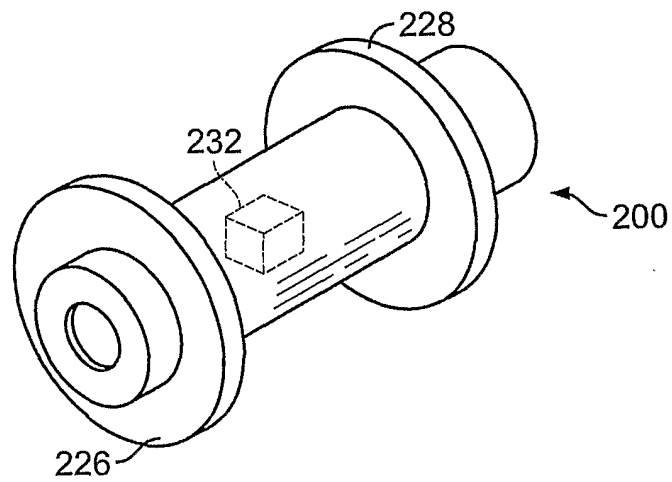

FIG. 4C

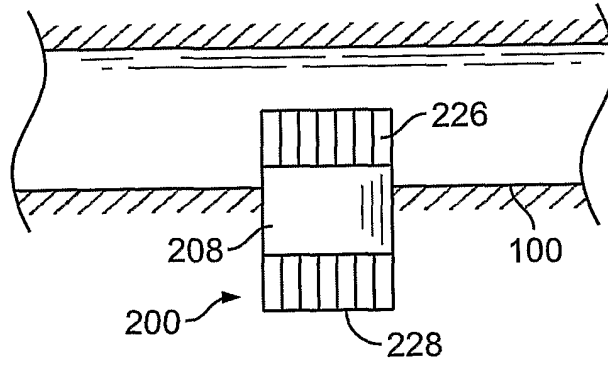

FIG. 5A

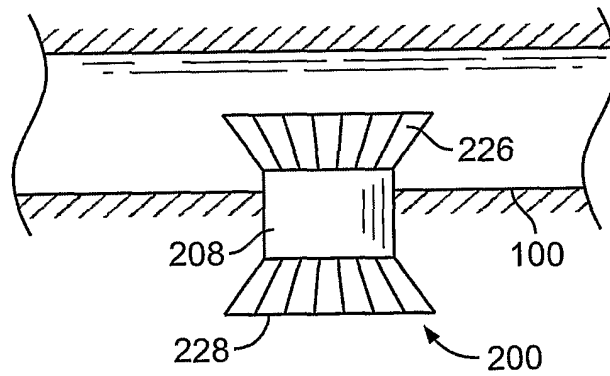

FIG. 5B

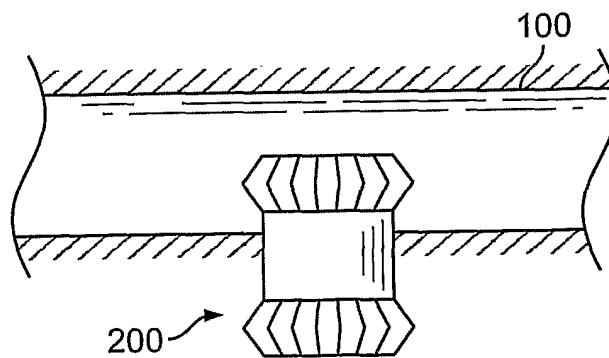

FIG. 5C

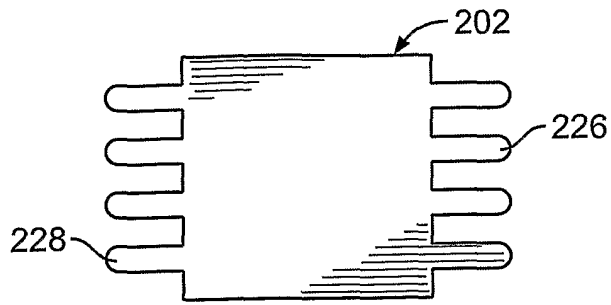

FIG. 5D

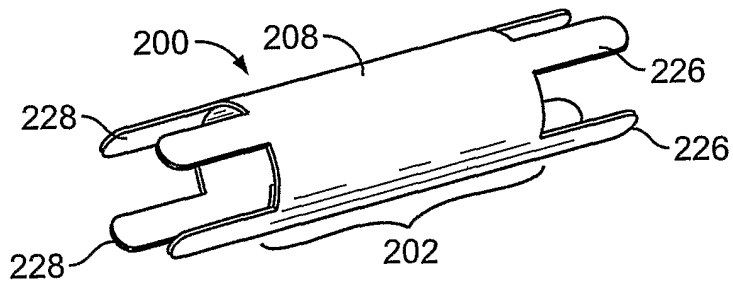

FIG. 5E

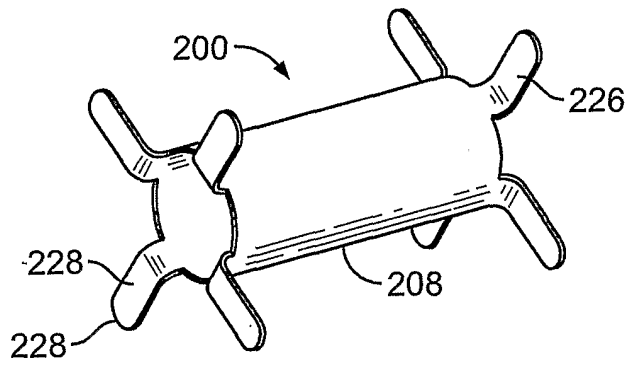

FIG. 5F

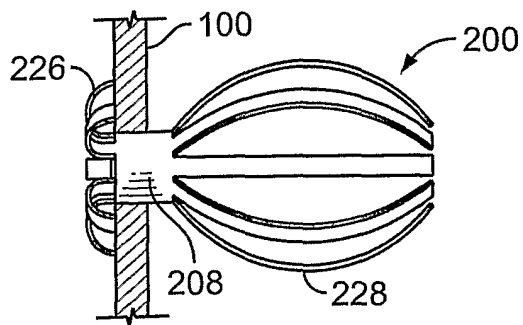

FIG. 5G

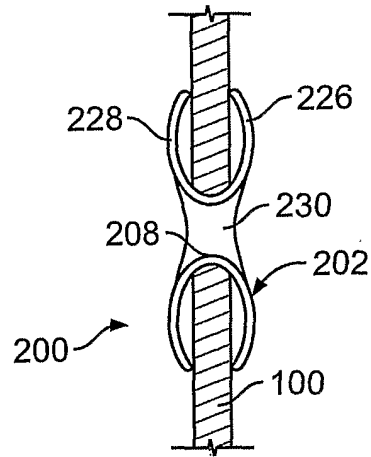

FIG. 6

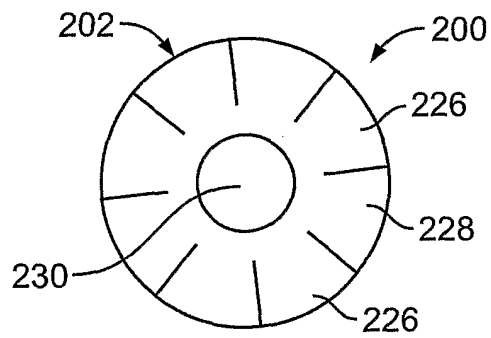

FIG. 7A

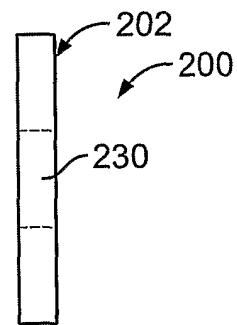

FIG. 7B

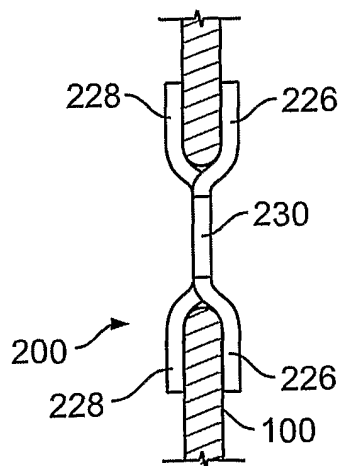

FIG. 7C

9/11

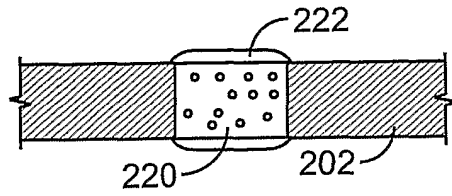

FIG. 8

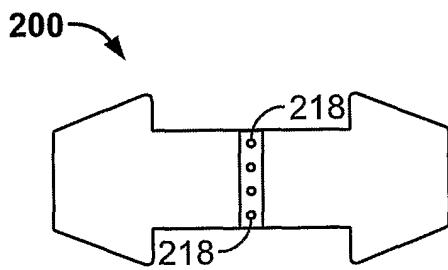

FIG. 9A

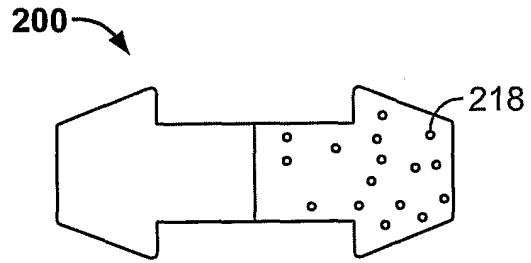

FIG. 9B

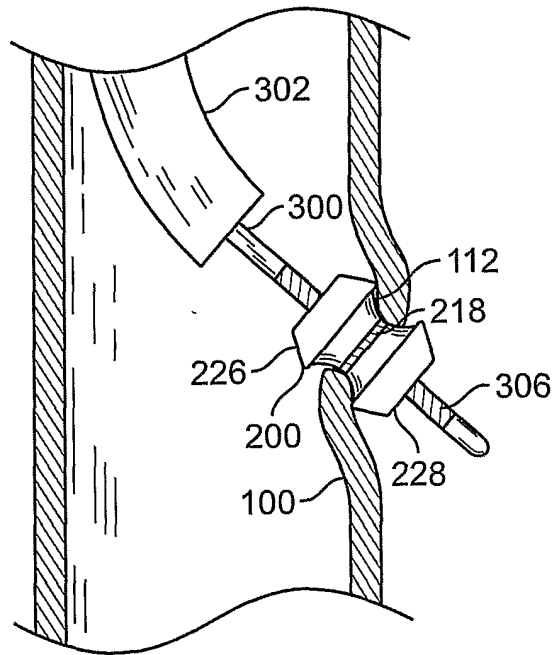

FIG. 9C

10/11

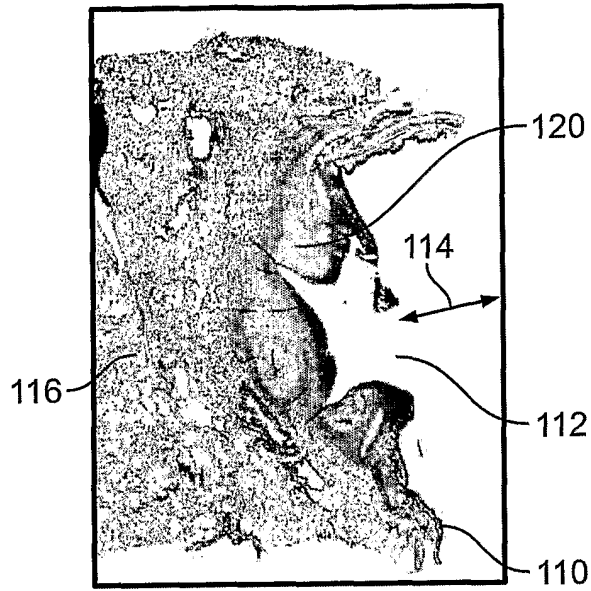

FIG. 10A

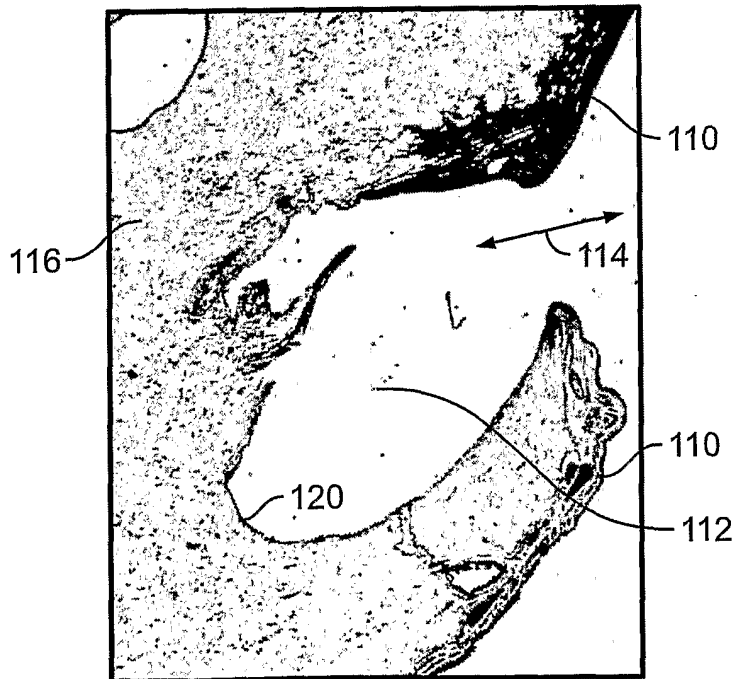

FIG. 10B

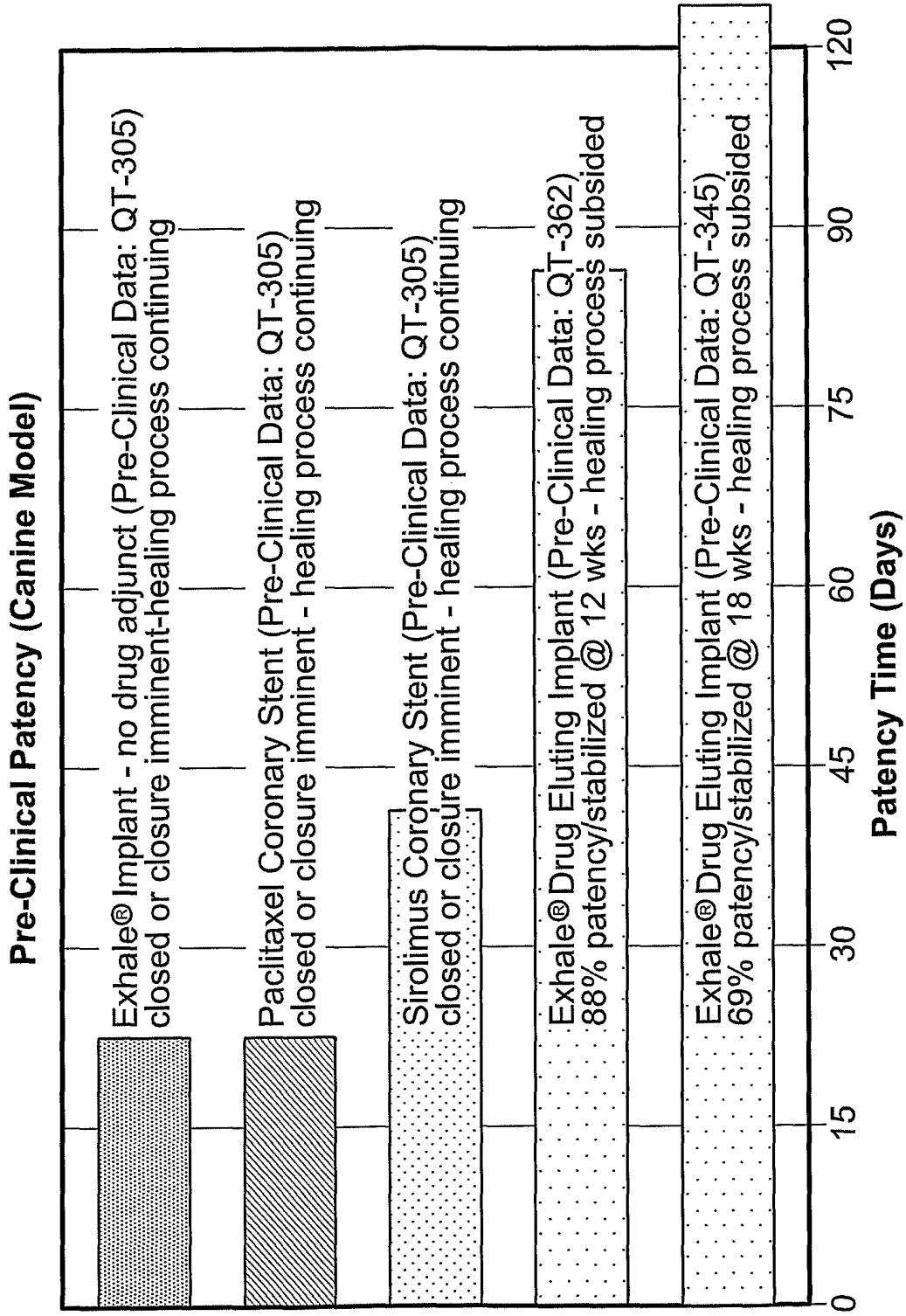

FIG. 11