

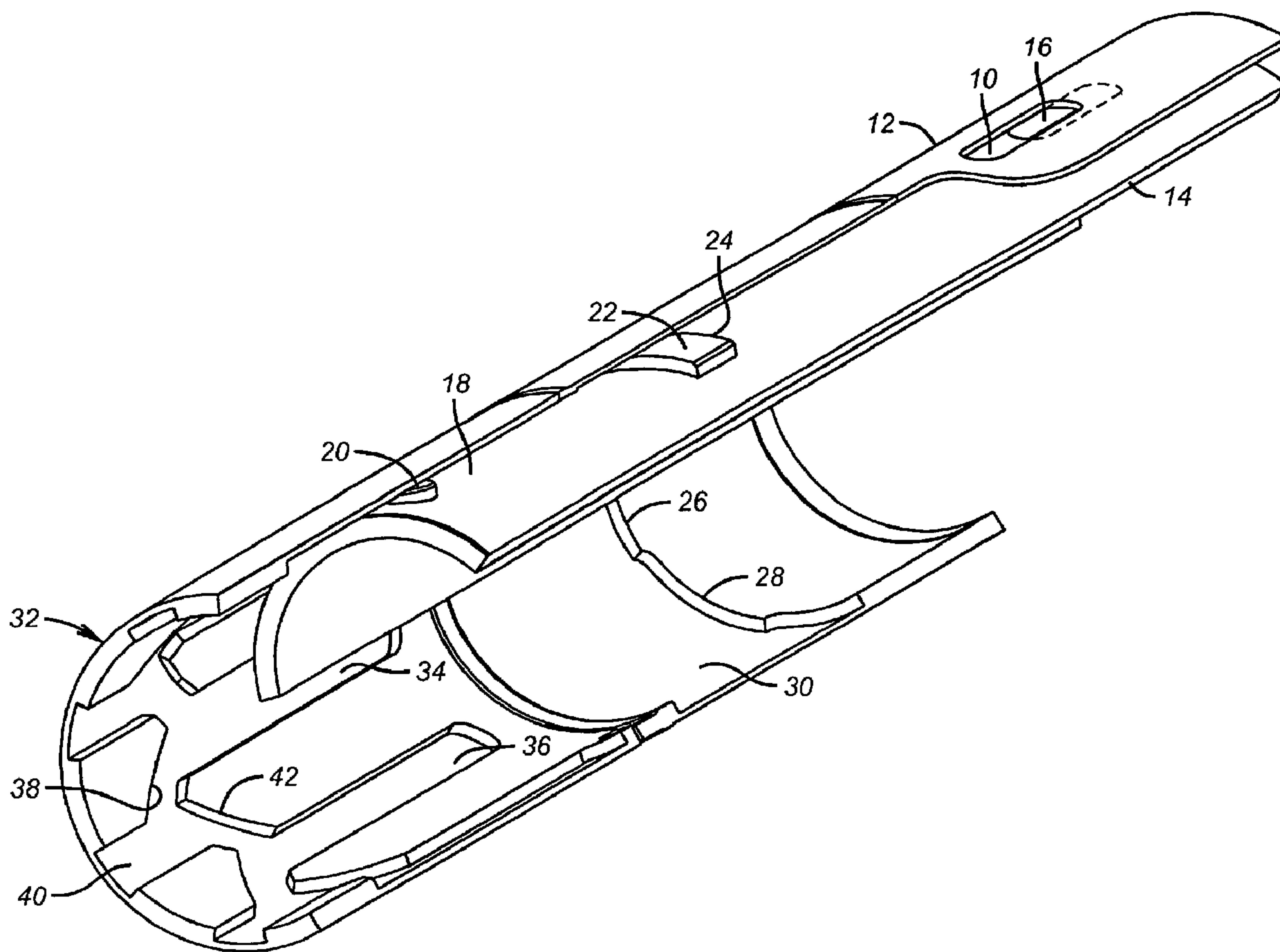

(86) Date de dépôt PCT/PCT Filing Date: 2003/06/30  
 (87) Date publication PCT/PCT Publication Date: 2004/01/22  
 (45) Date de délivrance/Issue Date: 2008/03/25  
 (85) Entrée phase nationale/National Entry: 2005/01/12  
 (86) N° demande PCT/PCT Application No.: US 2003/020546  
 (87) N° publication PCT/PCT Publication No.: 2004/007902  
 (30) Priorité/Priority: 2002/07/12 (US10/194,129)

(51) Cl.Int./Int.Cl. *E21B 23/00* (2006.01),  
*E21B 21/10* (2006.01), *E21B 34/14* (2006.01),  
*E21B 43/12* (2006.01)  
 (72) Inventeur/Inventor:  
 MYRON, WALTER J., US  
 (73) Propriétaire/Owner:  
 BAKER HUGHES INCORPORATED, US  
 (74) Agent: SIM & MCBURNEY

(54) Titre : APPAREIL D'INDEXAGE  
 (54) Title: INDEXING APPARATUS



(57) Abrégé/Abstract:

An indexing mechanism is disclosed that can put a tool in a variety of positions while downhole in the face of high static and dynamic loads. In the preferred application, the mechanism controls a movable sleeve on a downhole choke. It contains an

(57) **Abrégé(suite)/Abstract(continued):**

indexing feature comprising a pin movable in a series of slots. A piston restrained to move longitudinally engages and rotates an index sleeve to allow the pin to advance into the next J-slot track. A separate lug on the piston engages a radial face on the index sleeve to take the shock load and position the choke instead of allowing the pin to load against the closed end of the slot.

**ABSTRACT OF THE DISCLOSURE**

[ 0018] An indexing mechanism is disclosed that can put a tool in a variety of positions while downhole in the face of high static and dynamic loads. In the preferred application, the mechanism controls a movable sleeve on a downhole choke. It contains an indexing feature comprising a pin movable in a series of slots. A piston restrained to move longitudinally engages and rotates an index sleeve to allow the pin to advance into the next J-slot track. A separate lug on the piston engages a radial face on the index sleeve to take the shock load and position the choke instead of allowing the pin to load against the closed end of the slot.

HOU16127.1

## **INDEXING APPARATUS**

### **FIELD OF THE INVENTION**

[ 0001] The field of the invention is positioning systems generally and specifically applied to downhole adjustable chokes.

### **BACKGROUND OF THE INVENTION**

[ 0002] Sliding Sleeves have been used in downhole well completions for many years for controlling the flow of wells. These sleeves normally only have two positions, they are either fully open or fully closed and are not adjustable between these two extreme positions. These sleeves have evolved over time from requiring costly manual intervention to remotely operated. The next evolution of these sleeves requires that the flow area of these sleeves to be adjustable. These tools are now generically regarded as downhole chokes. Having the ability to adjust the flow area means that the operators can control the flow of fluids and gasses to and from the reservoir. The primary reason for this requirement is to maximize the efficiency of hydrocarbon recovery from the reservoir and minimize the risks and costs of producing these hydrocarbons.

[ 0003] The indexing mechanism to position the choke valve body in various positions could be subjected to very high forces above those initially envisioned if due to exposure to well fluids and conditions over a period of time the moving parts become much harder to move. Many times the use of available hydraulic pressure at the well head is used with a built in margin to be able to move the moving parts even against resistance caused by binding or particles in the path making the needed movements much more difficult. These designs tend to overpower the moving parts during normal

operation in the early goings, when there is not as much resistance to movement between or among the moving parts. These very high forces can cause failure of the parts resulting in a loss in the ability to manipulate the choke into the desired positions.

[ 0004] In the past devices have been created to covert axial motion to rotational motion downhole. This tool was complex, involving a toothed ratchet interacting with a helix on an elongated member. It is illustrated in U.S. Patent 5,584,342. This device was applied to cleaning debris out of pipe. More specific to operation of chokes requiring several positions are U.S. Patents 5,826,661 and 6,119,783, which use a sequential application and removal of pressure in conjunctions with slips that allow movement in predetermined amounts, each time the pressure is cycled on and off. This design involved complicated movements and small spring loaded parts that would have been of marginal utility in dealing with large differential pressures which could cause parts to slam together in a manner that could break them or make them stick. Other designs addressed the configuration of the stationary and movable ports, as illustrated in U.S. Patent 6,371,208. The commercial embodiment of this particular design employed a stepper motor operating a rack and pinion to achieve infinitely variable positions for a downhole choke. This system is very complex and expensive to manufacture and operate. Finally, J-slots have long been used in various downhole tools. In a J-slot the pin advances in a slotted track and comes to rest at the closed ends of individual slots so that the relative positions of the two bodies could be determined. The nature of prior art J-slots limited their application to light duty where there was no likelihood of the pin slamming into the end of the slot with great force where it could be damaged or sheared off. A tubing retrievable flow controller model TRFC-H made by Schlumberger uses an indexing system dependent on the location of a ratchet pin and an indexer pin to define multiple positions of a downhole choke.

[ 0005] What is needed is a design that involves simplicity while being able to tolerate large loads caused by high differential pressure applications and the high impact necessarily involved in such operations. The present invention accommodates such severe service by separation of the shifting mechanism from the ultimate positioning mechanism. These and other advantages of the present invention will be more readily understood by those skilled in the art from a review of the description of the preferred embodiment and the claims, which appear below.

#### **SUMMARY OF THE INVENTION**

[ 0006] An indexing mechanism is disclosed that can put a tool in a variety of positions while downhole in the face of high loads. In the preferred application, the mechanism controls a movable sleeve on a downhole choke. It contains an indexing feature comprising a pin movable in a series of slots. A piston restrained to move longitudinally engages and rotates an index sleeve to allow the pin to advance into the next J-slot track. A separate lug on the piston engages a radial face on the index sleeve to take the large loads and position the choke instead of allowing the pin to load against the closed end of the slot.

[ 0006a] Accordingly, in one aspect of the present invention there is provided a multi-position device for a tool, comprising:

a sleeve having a longitudinal axis; and

a piston operably connected to said sleeve through an indexing member to relatively rotate said piston and said sleeve, one of said piston and sleeve comprising a lug and the other of said piston and sleeve comprising a plurality of travel stops, longitudinally spaced from said indexing member for selective load bearing contact in a plurality of longitudinally spaced positions between said piston and said sleeve.

[ 0006b] According to another aspect of the present invention there is provided a multi-position device for a tool, comprising:

a sleeve having a longitudinal axis;

a piston operably connected to said sleeve through an indexing member to relatively rotate said piston and said sleeve, one of said piston and sleeve comprising a lug and the other of said piston and sleeve comprising a plurality of travel stops, longitudinally spaced from said indexing member for selective load bearing contact in a plurality of longitudinally spaced positions between said piston and said sleeve, said indexing member comprising a J-slot assembly, said J-slot assembly comprising a pin movable in a series of connected slots and wherein an end in each of said slots does not define the final position of said pin in that slot.

#### **BRIEF DESCRIPTION OF THE DRAWINGS**

[ 0006c] An embodiment of the present invention will now be described more fully with reference to the accompanying drawings in which:

[ 0007] Figure 1 is a cutaway perspective view of the indexing mechanism in a first position;

[ 0008] Figure 2 is the view of Figure 1 with the indexing mechanism in a second position showing a greater overlap between the movable and stationary apertures;

[ 0009] Figure 3 is a combination section and rolled out interior view of the apparatus; and

[ 0010] Figure 4 is a section view showing the operation of the choke using a series of fixed and movable overlapping openings.

### DETAILED DESCRIPTION OF THE PREFERRED EMBODIMENT

[ 0011] Those skilled in the art will appreciate that an adjustable choke works by relative movement between movable and fixed apertures so that the orifice size for the throttling function is varied. A greater overlap means an enlarged flow area and a lower pressure drop across the choke. The openings **10**, one of which is shown in Figure 1, that are fixed are generally disposed on a sleeve **12**. Sleeve **12** is fixedly mounted in a housing, not shown, to which the inlet and outlet flows are connected. Mounted adjacent the sleeve **12** and preferably concentrically therewith is a piston **14** having a series of movable openings **16**, one of which is shown in Figure 1. Piston **14** can be driven mechanically or hydraulically and can be biased toward urging contact between lug **22** and a corresponding circumferential shoulder surface such as **26** or **28**. In the position of Figure 1 openings **16** have moved into a partial overlapping position with openings **10** with the dashed lines indicating the level of misalignment between the movable and stationary openings.

[ 0012] The piston **14** is a tubular structure that is constrained to move only longitudinally. On its outer surface **18** it has a pin **20** and a lug **22**. In the preferred embodiment, the pin **20** is aligned longitudinally with lug **22** although such alignment is not mandatory. The shape of lug **22** can be varied although it is preferred that it have a long dimension **24** for contact with circumferential shoulder surfaces such as **26** and **28** located on the inside surface **30** of the index sleeve **32**. Other shapes for the travel stop than a circumferential shoulder are also contemplated. Index sleeve **32** is preferably mounted over piston **14** such that pin **20** is initially disposed in one of a plurality of parallel tracks of which tracks **34** and **36** are shown in Figure 1. The index sleeve is retained so that it can rotate about its central axis but it cannot translate. When the piston **14** is moved by any one of a variety of different motive forces, it translates moving the pin **20** in a given slot, such as **34**, for



example. Eventually, the pin 20 engages tapered surface 38 on index sleeve 32. Since the piston 14 is constrained against rotation about its central axis, the index sleeve 32 which can rotate does so as the pin 20 enters slot 40. Thereafter, when the piston 14 is urged to move in the opposite direction, pin 20 now engages sloping surface 42 between slots 34 and 36 to force the index sleeve to rotate in the same direction as before to put slot 36 in alignment with pin 20. As a result of rotations of the index sleeve 32, circumferential shoulder surface 28 has rotated into alignment with long dimension 24 of lug 22. Since surface 28 is higher than surface 26, the piston 14 can travel further up before surface 24 engages thus reducing the overlap between openings 10 and 16. The position is determined by the engagement of the lug 22 with the surface 28 or others like it that are distributed in a circular fashion in such a manner that stroking the piston 14 back and forth enough times will allow the choke to go from fully closed to fully open and back again in the number of increments determined by the number of slots such as 34 or 36 and the actual positions will be determined by the placement of the circumferential shoulder surfaces such as 26 and 28. The travel stop that takes the shock of each intermediate position is the lug 22 hitting a counterpart shoulder surface and not the pin 20 engaging a closed end of a slot such as 34. Unlike a typical J-slot of past designs, the height of the individual slots becomes immaterial to the final placement of the parts with respect to each other. As shown in the rolled out interior view of Figure 3, the slot peaks 44 are identical in height but are not required to be. This is because it is the engagement of lug 22 with a respective shoulder such as 28 on the index sleeve 32 precludes the pin from loading against slot peak 44 or even from contacting it at all, depending on the layout of the parts. In essence, the pin and slot serves the purpose of altering alignment between the lug 22 and the next shoulder in line such as 28. When they contact, taking up the load, the new position of the choke is defined. The large load is not taken

up on the pin **20** colliding with a slot peak **44**. This layout allows the choke to close incrementally and then to open incrementally. The increments can be of equal proportions or they can be different.

[ **0013**] Those skilled in the art will appreciate that the indexing mechanism is simple and reliable, using a mechanism to turn translation into rotation. Other mechanisms than a J-slot are contemplated to turn translation into rotation as long as the intermediate positions are determined by another mechanism that is beefy enough to take the large load of each intermediate position. In the preferred embodiment, the J-slot is used for repositioning a separate lug **22** against a series of shoulders, such as **28**, while the pin **20** avoids the shock of collision with a slot peak **44**.

[ **0014**] While the preferred application is for a downhole choke, other tools can employ the present invention. The mechanism can move sliding sleeves or any other valves whether used on the surface or downhole. It can be used to operate downhole locks, or as a release device on a running tool or any number of tools that would benefit from the incremental movements as explained and more particularly where the loads are significant and the indexing mechanism needs to be less rugged yet reliable in operation. Large shock loads and large loads caused by differentials in pressure of over 10,000 PSI are contemplated.

[ **0015**] The placement of the pin **20** and the slots such as **34** and **36** can be transposed so that the pin **20** is on the index sleeve **32** that is constrained to translate while the piston **14** is allowed to rotate. The lug **22** can be on the index sleeve **32** and the travel stops can be on the outer surface of the piston **14**. The openings **16** could then be on the index sleeve **32**.

[ **0016**] The movement of pin **20** in Figure 3 is consistent with a rotational bias on index sleeve **32** shown schematically by arrow **48**. This bias can be reversed as indicated schematically by arrow **46**. The direction of the bias can be manipulated from the surface and will control whether the openings

**10** and **16** are moving incrementally toward alignment or misalignment. That way a choke that is half open does not need to be moved to fully open before it can close. The same reciprocal motion of the piston **14** can allow the choke to move toward open or closed as determined from the surface.

[ **0017**] The foregoing disclosure and description of the invention are illustrative and explanatory thereof, and various changes in the size, shape and materials, as well as in the details of the illustrated construction, may be made without departing from the spirit of the invention.

**What is claimed is:**

1. A multi-position device for a tool, comprising:  
a sleeve having a longitudinal axis; and  
a piston operably connected to said sleeve through an indexing member to relatively rotate said piston and said sleeve, one of said piston and sleeve comprising a lug and the other of said piston and sleeve comprising a plurality of travel stops, longitudinally spaced from said indexing member for selective load bearing contact in a plurality of longitudinally spaced positions between said piston and said sleeve.
2. The tool of claim 1, wherein one of said piston and said sleeve is constrained to translation and the other of said piston and said sleeve is constrained to rotation.
3. The tool of claim 1, wherein said indexing member is precluded from loading by earlier engagement of said lug to one of said travel stops.
4. The tool of claim 1, wherein said indexing member comprises a J-slot assembly.
5. The tool of claim 1, wherein said lug is capable of absorbing impacts when striking a travel stop created by differential pressures of over 10,000 pounds per square inch (PSI).
6. The tool of any one of claims 1 to 5, wherein said lug is generally rectangularly shaped and said travel stops comprise a series of shoulders in a stair step arrangement.

7. A multi-position device for a tool, comprising:
  - a sleeve having a longitudinal axis;
  - a piston operably connected to said sleeve through an indexing member to relatively rotate said piston and said sleeve, one of said piston and sleeve comprising a lug and the other of said piston and sleeve comprising a plurality of travel stops, longitudinally spaced from said indexing member for selective load bearing contact in a plurality of longitudinally spaced positions between said piston and said sleeve, said indexing member comprising a J-slot assembly, said J-slot assembly comprising a pin movable in a series of connected slots and wherein an end in each of said slots does not define the final position of said pin in that slot.
8. The tool of claim 7, wherein said lug engaging one of said travel stops prevents said pin from engaging an end of a respective slot.
9. The tool of claim 8, wherein said pin is constrained to translate while said connected slots are constrained to rotate.
10. The tool of claim 9, wherein said slots comprise intermediate sloping surfaces and wherein contact between said pin that is constrained to translate and said intermediate sloping surfaces, results in rotational movement of said slots that are constrained to rotate.
11. The tool of claim 9, wherein rotation of said slots causes the alignment of a different travel stop with said lug.
12. The tool of claim 11, further comprising:

a housing mounted around said sleeve; and

a fluid inlet and outlet in said housing, one of said piston and said sleeve further comprising an opening capable of movement toward alignment and misalignment with one of said fluid inlet and outlet in said housing determined by which travel stop is engaged by said lug.

13. The tool of claim 12, wherein said lug and said opening are on said piston and said slots and said travel stops are on said sleeve.

14. The tool of claim 12, wherein said lug and said opening are on said sleeve and said slots and said travel stops are on said piston.

15. The tool of claim 12, wherein said opening is moved into alignment and then misalignment from one of said fluid inlet and outlet in incremental steps defined by engagement of said lug to the next travel stop in sequence in either direction.

16. The tool of claim 15, wherein said opening is moved into alignment and then misalignment from one of said fluid inlet and outlet in incremental steps defined by engagement of said lug to the next travel stop in sequence in one direction.

17. The tool of any one of claims 7 to 16, wherein said lug is generally rectangularly shaped and said travel stops comprise a series of shoulders in a stair step arrangement.

18. The tool of claim 17, wherein said sleeve is mounted concentrically over said piston.

19. The tool of claim 18, wherein said piston is driven hydraulically.
20. The tool of claim 18, wherei said piston is driven mechanically.

+

1/4

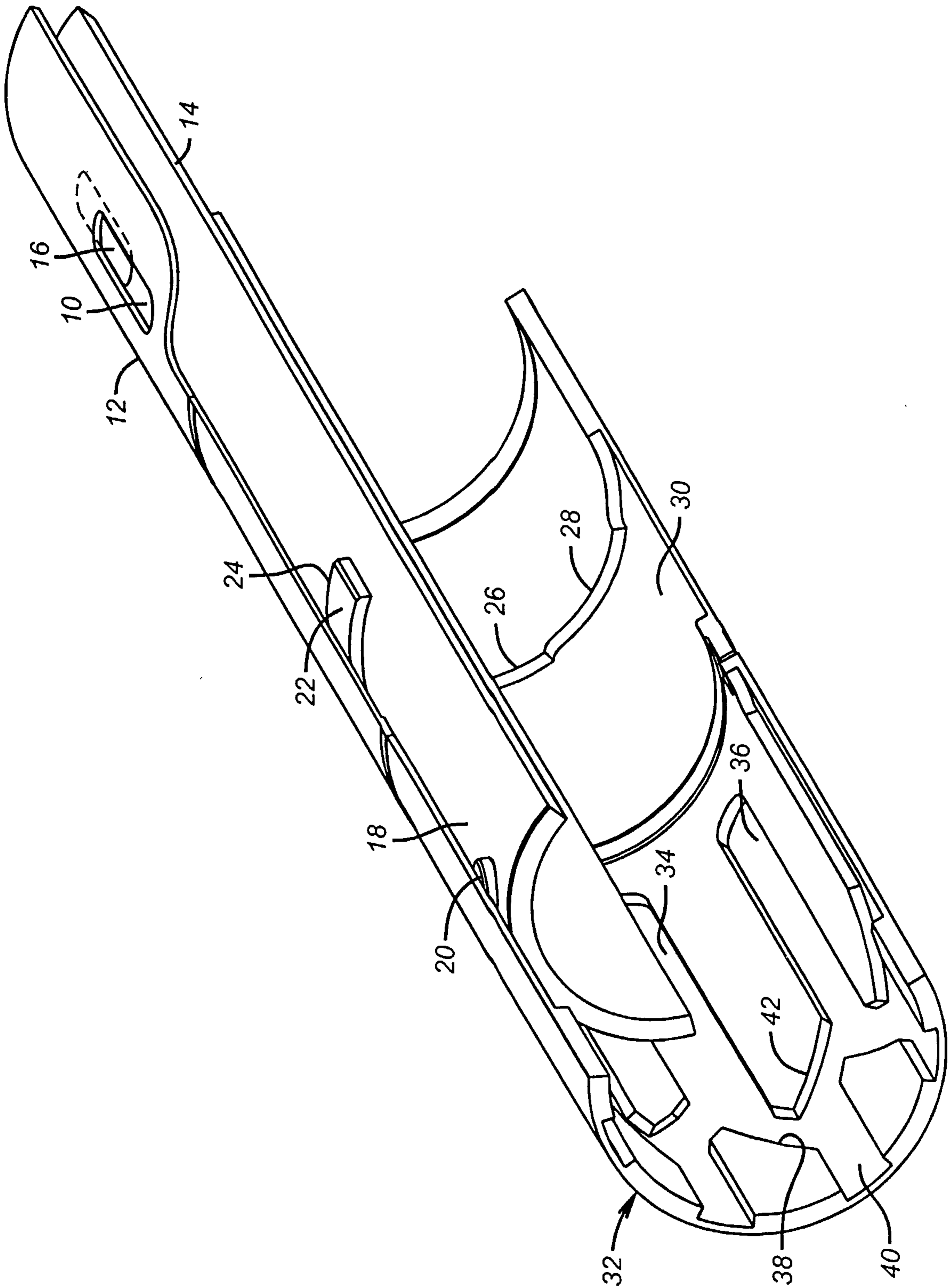

**FIG. 1**



+

2/4

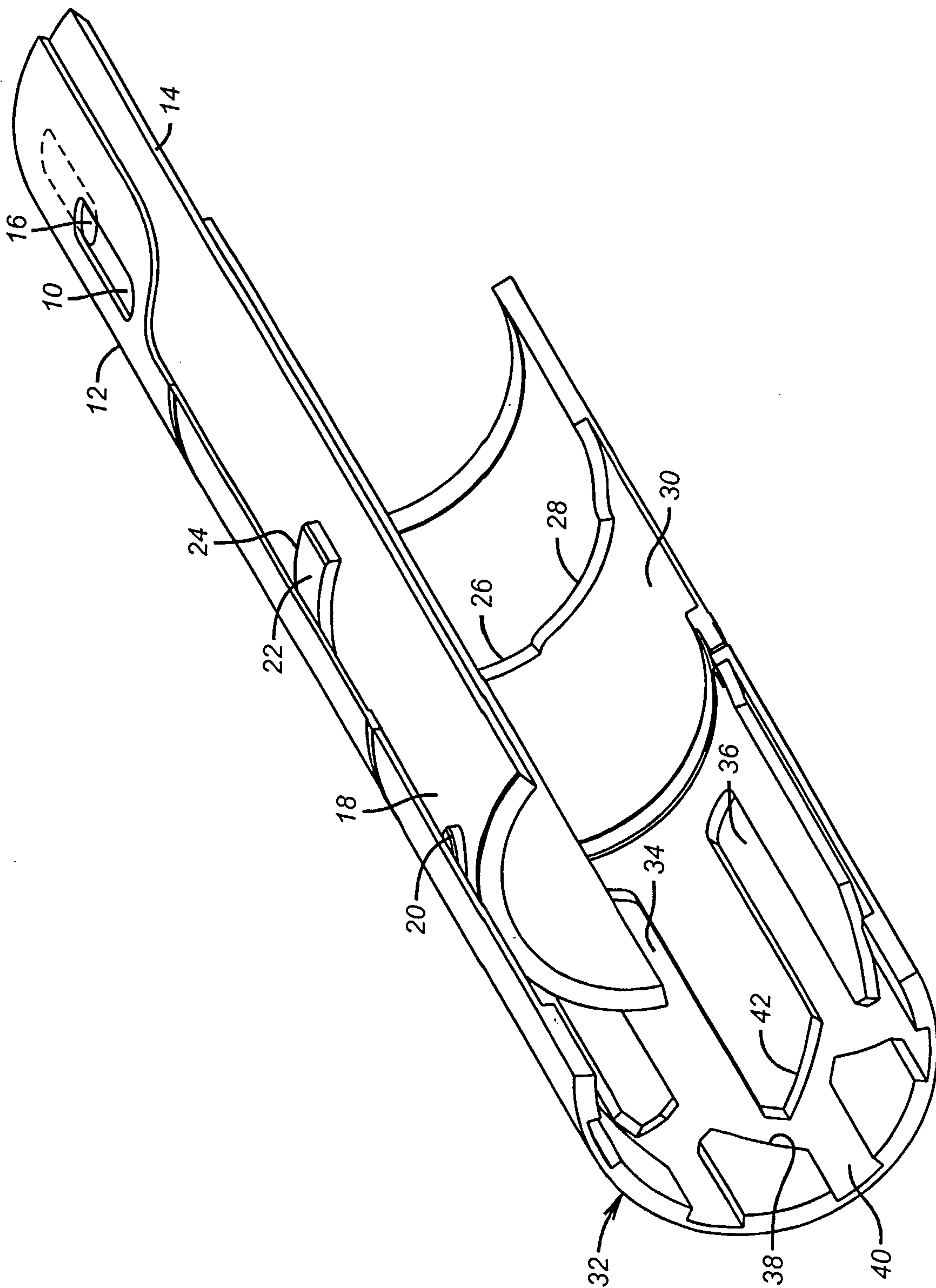
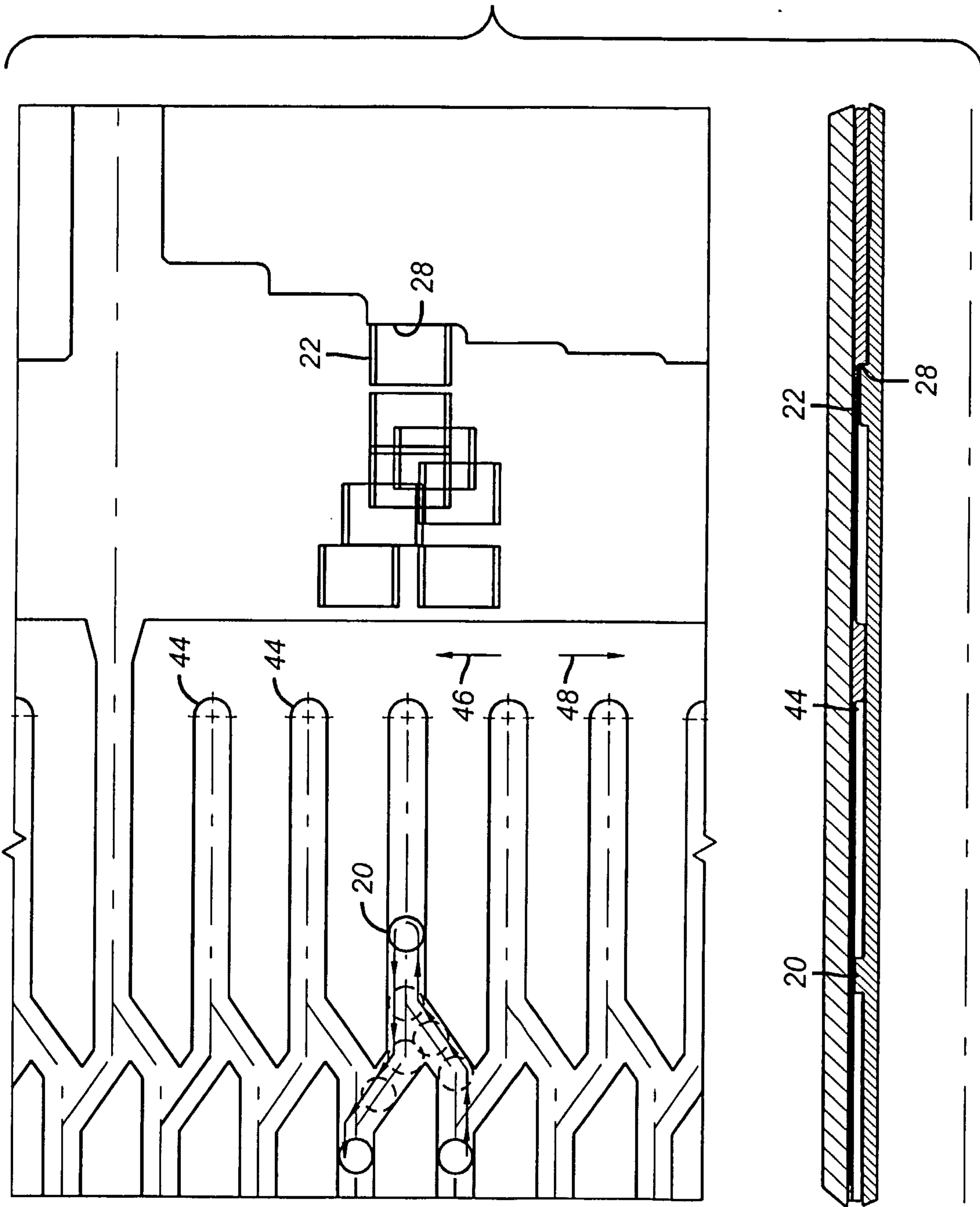

FIG. 2

+

3/4



**FIG. 3**

+

4/4

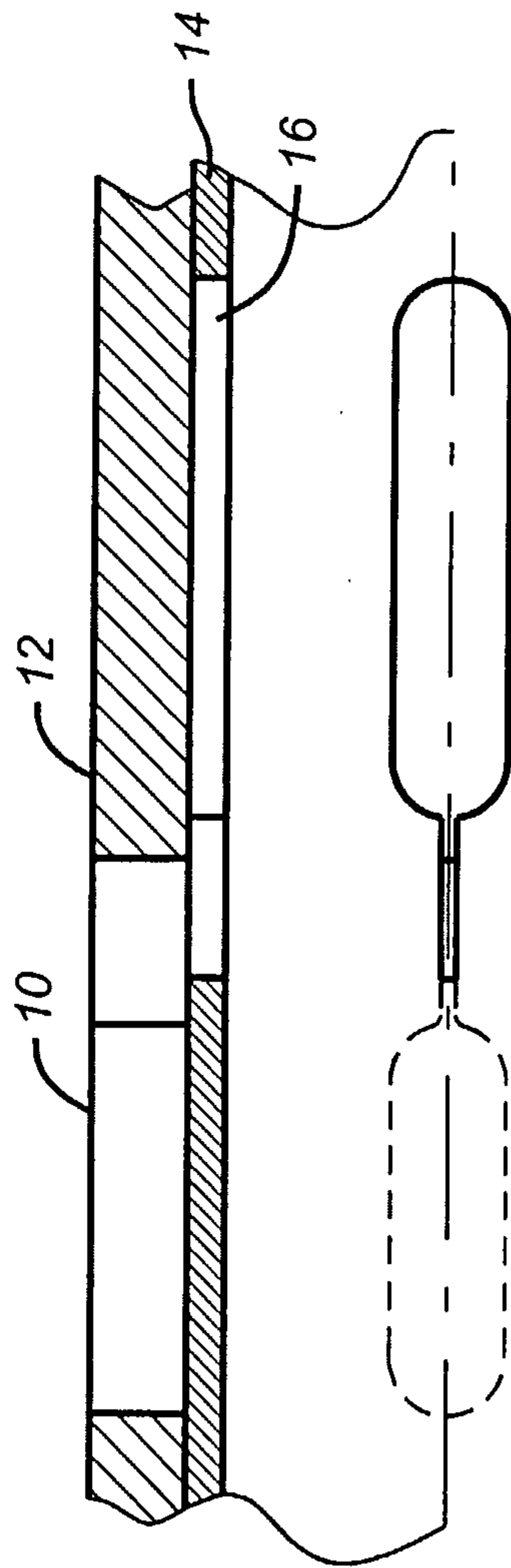

**FIG. 4**

