

110405

Claus Van Haagen assr. etc.,
— Portable Drilling Tool. —

PATENTED DEC 20 1870

Fig. 1.

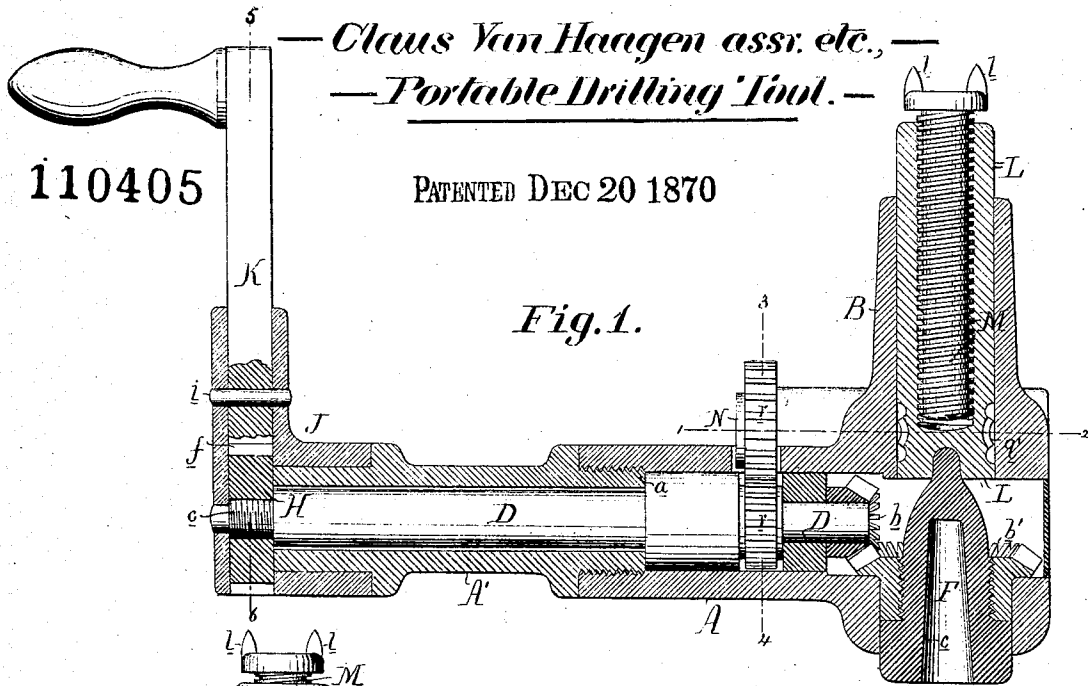

Fig. 3.

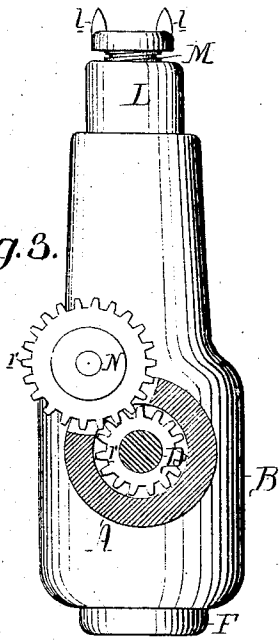

Fig. 2.

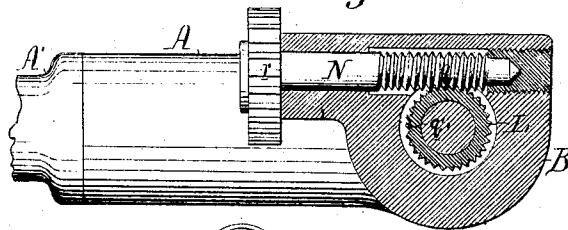

Fig. 5.

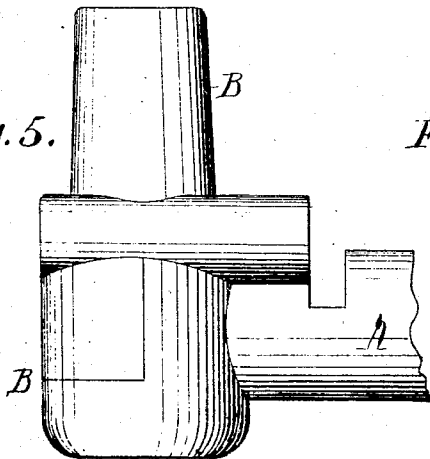
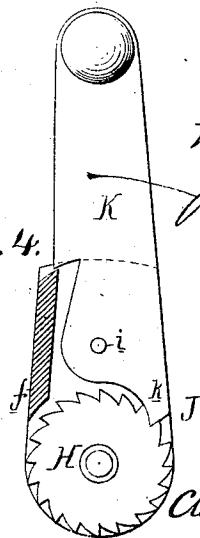

Fig. 4.



Witnesses

Jns. B. Harding
John Clarke

Claus Van Haagen
by his Attor
Horson and son

United States Patent Office.

CLAUS VAN HAAGEN, OF PHILADELPHIA, PENNSYLVANIA, ASSIGNOR
TO HIMSELF AND ANTHONY VAN HAAGEN, OF SAME PLACE.

Letters Patent No. 110,405, dated December 20, 1870.

IMPROVEMENT IN PORTABLE DRILLING-TOOLS.

The Schedule referred to in these Letters Patent and making part of the same.

I, CLAUS VAN HAAGEN, of Philadelphia, county of Philadelphia, State of Pennsylvania, have invented a Portable Drilling-Tool, of which the following is a specification.

Nature and Object of the Invention.

My invention consists of a portable drilling-tool, too fully described hereafter to need preliminary explanation, the tool being so constructed as to form a self-feeding boring implement, well adapted for general use in machine-shops, and especially in contracted spaces.

Description of the Accompanying Drawing.

Figure 1 is a longitudinal section of my improved drilling-tool;

Figure 2, a sectional plan of the same, on the line 1-2, fig. 1;

Figure 3, a transverse vertical section on the line 3-4, fig. 1;

Figure 4, a section on the line 5-6, fig. 1; and
Figure 5, an exterior view of part of the casing of the tool.

General Description.

The tubular body or casing of the instrument consists of two main portions, A and B, arranged at right angles to each other, the portion A having a detachable extension, A'.

A spindle, D, is arranged to turn in the portion A and extension A' of the casing, and has at its inner end a bevel-wheel, *b*, gearing into a larger bevel-wheel, *b'*, of a short bottom spindle, F, the latter being arranged to turn in the portion B of the casing, as will be more fully explained hereafter, and having a tapering socket, *c*, for the reception of the drill.

A ratchet-wheel, H, is screwed onto the end *c* of the spindle D, and is contained within the recessed enlargement *f* of a sleeve, J, which is adapted to and arranged to turn freely upon the extension A' of the casing, and within the same recessed enlargement of the sleeve is also contained the crank or arm K, by which the drill is operated.

This arm is hung to a pin, *i*, on the sleeve, and is permitted to have a sufficient vibrating motion upon the said pin to enable its pawl-like short arm to operate the ratchet-wheel, (see fig. 4.)

The tapering end of the drill, carrying spindle F, fits into and turns in the recessed end of a spindle, L, which is also arranged to turn in the portion B of the body of the casing.

This spindle L has a threaded recess extending almost entirely through it, to which recess is adapted a screw-rod, M, furnished at its outer extremity with a suitable head, on which are two or more teeth or projections, *l*, intended to be forced against any fixed

object opposite to the point where the hole has to be bored by the drill.

Upon the tubular spindle L is formed a worm-wheel, *g*, to which is adapted a worm, *q*, on a spindle, N, which receives its motion through the medium of cog-gearing *r* from the spindle D.

This worm and wheel, together with the spindle L and screw-rod M, constitute an automatic "feed" for the cutting-tool, and form an important feature of my invention.

In using the above-described tool, the point of the drill is adjusted to the desired position upon the object in which it is required to bore a hole, and the points *l l* of the feed-screw M are forced into or against any fixed object which will afford a bearing or abutment for and prevent the said screw from turning.

The operator then steadies the instrument with one hand, while with the other he manipulates the crank or lever K, turning the same completely around in the direction of the arrow, fig. 4, if there are no obstacles in the way to prevent such free motion, or, if the work has to be performed in a contracted situation, the handle is merely reciprocated, so as to operate the ratchet-wheel. The result, however, will, in both cases, be the same, namely, a rotation of the spindle D and automatic feeding of the same, until a hole of the desired depth has been bored by the drill.

In order to withdraw the tool from the hole which it has drilled, it will be only necessary to reverse the motion of the crank until the feed-screw has been drawn back into the spindle L.

The peculiar form of the instrument enables it to be used in contracted situations with much greater facility than the ordinary straight ratchet-drill.

It has also the great advantage over the latter of being fed automatically and regularly, instead of at irregular intervals and by hand, as usual.

The uniformity of the feed also enables twist or spiral drills to be employed with much less risk of breaking than in ordinary ratchet-drills.

Claims.

The combination of the casing A B, driving-spindle D, cutter spindle F, gear *b b'*, screw M, nut L, and the screw-shaft N, or other devices, whereby motion may be communicated from the driving-shaft to the nut.

In testimony whereof I have signed my name to this specification in the presence of two subscribing witnesses.

C. VAN HAAGEN.

Witnesses:

WM. A. STEEL,
F. B. RICHARDS.