

(12) STANDARD PATENT
(19) AUSTRALIAN PATENT OFFICE

(11) Application No. **AU 2006285331 B2**

(54) Title
Pull tab activated sealed packet

(51) International Patent Classification(s)
B65D 75/30 (2006.01) **B65D 75/58** (2006.01)

(21) Application No: **2006285331** (22) Date of Filing: **2006.06.02**

(87) WIPO No: **WO07/027255**

(30) Priority Data

(31) Number	(32) Date	(33) Country
11/217,110	2005.08.31	US

(43) Publication Date: **2007.03.08**

(44) Accepted Journal Date: **2011.05.26**

(71) Applicant(s)
Kimberly-Clark Worldwide, Inc.

(72) Inventor(s)
Bauer, Walter G.

(74) Agent / Attorney
Freehills Patent & Trade Mark Attorneys, Level 38 MLC Centre Martin Place, Sydney, NSW, 2000

(56) Related Art
US 2001/0030192
US 3917116
US 3053385
US 506982

PULL TAB ACTIVATED SEALED PACKET**BACKGROUND**

Sealed disposable pouches or packets for storing and dispensing fluid compositions are well known in the art. Examples include food product packets, such as condiment packets, and medical products packets, such as lotion or ointment packets. Many types of these conventional packets are designed to be torn or separated along a defined location on the packet. However, this action requires a relatively high degree of manual dexterity and can be difficult for children and the elderly. Also, the tearing action often results in a sudden and uncontrolled release of the packet contents. Other packets are designed to burst along a frangible seam or portion when pressure is applied to the packet. Such devices are, however, not selective and burst under sufficient pressure, regardless of whether that pressure is applied intentionally by a user, or is applied unintentionally during handling, shipping, or storage.

It is also known to use packets or pouches within other structures for various purposes. For example, U.S. Pat. No. 6,508,602 describes an applicator intended to distribute a fluid from an enclosed reservoir when pressure is applied to the applicator causing the reservoir to rupture. To prevent the reservoir from bursting prematurely, the '602 patent proposes to fold the entire applicator such that the reservoir within the applicator is also folded along an axis that isolates the rupturable portion of the reservoir. To use the applicator, a consumer must unfold the device prior to inserting their hand into the applicator to apply sufficient pressure for bursting the reservoir. This configuration requires additional folding steps and packaging considerations, such as additional restraining structure or packaging materials to ensure that the applicator remains folded prior to use. This is not a desirable situation from a manufacturing and packaging standpoint.

The art is thus continually seeking improved packet or reservoir designs that are reliable and yet easy to open and use by consumers.

Reference to any prior art in the specification is not, and should not be taken as, an acknowledgment or any form of suggestion that this prior art forms part of the common general knowledge in Australia or any other jurisdiction or that this prior art could reasonably be expected to be ascertained, understood and regarded as relevant by a person skilled in the art.

As used herein, except where the context requires otherwise, the term "comprise" and variations of the term, such as "comprising", "comprises" and "comprised", are not intended to exclude further additives, components, integers or steps.

SUMMARY

Objects and advantages of the invention will be set forth below in the following description, or may be obvious from the description, or may be learned through practice of the invention. One object of the invention, alternative or additional to any other object, is to provide the public with a useful choice.

In one aspect of the invention there is provided a pull activated packet for storing and dispensing any manner of fluid composition,

opposed first and second material layers sealed together along a perimeter defining a sealed cavity between said opposed layers, and a fluid composition contained within said cavity;

exit structure defined in said first material layer through which said composition exits said cavity in use of said packet;

a flap defined by a portion of said opposed layers folded at a first fold line so as to extend over and releasably seal to said first material layer over said exit structure, said first fold line defined along a portion of said sealed perimeter that delimits said cavity such that said composition is not contained in said flap;

wherein to open said packet, said flap is pulled by a user causing said flap to peel away from said first material layer and unseal from said exit structure, whereby said fluid composition is dispensed from said exit structure upon pressure being applied to said packet; and

wherein said flap is folded at a second fold line disposed such that said exit structure is folded adjacent said second material layer and is isolated from said cavity by said second fold line.

In another aspect of the invention there is provided a pull activated packet for storing and dispensing any manner of fluid composition, opposed first and second material layers sealed together along a perimeter defining a sealed cavity between said opposed layers, and a fluid composition contained within said cavity;

exit structure defined in said first material layer through which said composition exits said cavity in use of said packet;

a flap defined by a portion of said opposed layers folded at a first fold line so as to extend over and releasably seal to said first material layer over said exit structure, said first fold line defined along a portion of said sealed perimeter that delimits said cavity such that said composition is not contained in said flap;

wherein to open said packet, said flap is pulled by a user causing said flap to peel away from said first material layer and unseal from said exit structure, whereby said fluid composition is dispensed from said exit structure upon pressure being applied to said packet; and

wherein said first and second opposed material layers comprise thermoplastic materials heat sealed together along a perimeter seal defining said cavity, said flap heat sealed directly to said first material layer over said exit structure in a seal zone that circumscribes said exit structure, and further comprising an insert within said cavity disposed to prevent said first and second material layers from sealing together in said seal zone upon heat sealing said flap to said first material layer.

Also described herein is a novel packet design for storing and dispensing any manner of fluid composition. The packet is easy to manufacture, maintains structural integrity during storage, will not burst during normal handling, and is relatively simple to open and use. The packet is not limited by its intended use or type of fluid composition contained within the packet. For example, the packet may contain any manner of medical lotion, ointment, salve, or other medical fluid composition. In other embodiments, the fluid composition may be a cleaning or polishing agent. The packet may have particular usefulness in the food service industry as a condiment packet. It should thus be appreciated that the packet have utility in any number of fields, and all such uses are within the scope and spirit of the description.

The packet may be defined by opposed first and second material layers sealed along a perimeter seal to define a sealed cavity. Exit structure is defined through the first material layer, and may be one or more openings, such as a series of holes or slits in the material layer, or a weakened portion of the packet material created by embossing, laser scoring, mechanical scoring, other known

methods for weakening a film structure. The exit structure communicates with the internal cavity of the packet in which the fluid composition is contained.

Baffle structure, or other restricting structure, may be provided in the cavity to aid in controlling the flow rate of the fluid composition out of the packet. The baffle structure may be defined by one or more seals between the opposed material layers of the packet that define a restrictive flow path for the fluid composition.

A flap is defined by a portion of the opposed packet material layers folded at a first fold line so as to extend over and releasably seal to the first material over the exit structure. In its folded and sealed configuration, the flap may be grasped directly by the user, or a flap extension may be provided having a shape and configuration to be readily grasped by the user. While holding the packet, the user simply pulls the flap, or flap extension, in a direction that causes the flap to peel away from the first material layer and unseal from over the exit structure. The fluid

composition is then delivered out of the packet through the exit structure upon pressure being applied to the packet by the user.

In a particular embodiment, a seal line between the opposed material layers of the packet may be provided between the flap and the cavity, with the flap folded
5 over at this seal line so as to extend over the exit structure and seal to the first material layer in a first pass. The flap may then be folded back in an opposite direction at a second fold line so as to extend back over the exit structure in a second pass. Although not necessary for seal integrity of the flap over the exit
10 structure, the flap may be releasably sealed to the second material layer adjacent the second fold line so that the flap is held in a compact and tight configuration against the packet prior to use.

The packet material layers can vary. In certain embodiments, laminated metallized films may be desired depending on the nature of the fluid composition within the packet. In a particular embodiment, the opposed material layers of the
15 packet include heat sealable thermoplastic materials, such as thermoplastic film layers, heat-sealed together along a perimeter seal using conventional heat seal techniques. The flap may be heat sealed directly to the first material layer in a seal zone that circumscribes the exit structure. The seal zone may be a border around the exit structure, or a continuous seal zone that encompasses the exit
20 structure. In this embodiment, the first material layer may have an outer surface or layer with heat seal characteristics different from those of an inner surface of the material. In this way, the flap may be heat-sealed against the first material layer at heat seal conditions (i.e., temperature, dwell time, and pressure) different from those needed to heat seal the opposed material layers together along the
25 perimeter seal. The flap seal may thus be considered weaker or "frangible" as compared to the perm perimeter seal defining the cavity, or other pouch structure. The first material layer may be, for example, a multi-layered film with different layers having different melt points. The layers may be co-extruded or laminated layers, with one of the outer surface layers including a sealant material or coating,
30 such as Surlyn® from Dupont, or a blend of polybutylene with ethylene vinyl acetate or ultra low density ethylene copolymers, polyolefin plastomers, or polyethylene. Sealant layers made with these resins or blends may provide seals

of varying seal strength as compared to the base polymer depending upon seal temperature, dwell time, and pressure. Thus, the seal between the flap and outer surface of the first material layer can be made selectively frangible as compared to the permanent perimeter seal defining the packet cavity by varying the sealing
5 conditions.

The second material layer may be the same or a different thermoplastic film as compared to the first material layer.

In still another embodiment, the flap is folded at a second fold line disposed such that the exit structure (with sealed flap) is folded in a direction so as to lie
10 adjacent to the second material layer. In this configuration, the exit structure is isolated from the contents of the cavity by the second fold line. The flap is releasably sealed to the second material layer adjacent to the second fold line. In this embodiment, the opposed material layers may be thermoplastic materials heat-sealed together along a perimeter seal defining the cavity. The flap is heat
15 sealed directly to the first material layer over the exit structure in a seal zone that circumscribes the exit structure, and is heat-sealed directly to the second material layer adjacent the second fold line. The first and second material layers may be multi-layer films having an outer sealant layer as discussed above with heat seal characteristics such that the flap is heat sealed against the first and second
20 material layers in a frangible releasable seal as compared to the perimeter seal defining the cavity.

With yet another embodiment, the packet may be defined by a combination of opposed material layers heat sealed together along a perimeter seal defining the cavity, with the flap heat sealed directly to the first material layer over the exit
25 structure in a seal zone that circumscribes the exit structure. The flap seal is formed at a temperature, dwell time, and pressure so as to be frangible as compared to the perimeter seal. In order to prevent the opposed layers from sealing to each other in the flap seal zone when heat sealing the flap to the first material layer, an insert device may be disposed within the cavity at a location
30 relative to the seal zone to prevent the material layers from sealing together within the cavity. The insert may be any material that will not seal to both of the opposed material layers upon heat-sealing the flap to the first material layer. In a particular

embodiment, the insert may be a strip of thermoplastic material having at least one surface that will not heat seal to the opposed material layers. The opposite surface may have a sealant layer so that the insert material seals to the bottom material layer within the cavity. The insert thus defines a channel or conduit to ensure that the fluid composition is free to flow out of the exit structure upon the flap being peeled away from the first material layer.

Aspects of the invention will be described in greater detail below by reference to particular embodiments illustrated in the figures.

BRIEF DESCRIPTION OF THE DRAWINGS

10 Fig. 1 is a perspective view of a packet embodiment according to the present invention.

Fig. 2A is a perspective view of the packet according to Fig. 1 prior to being folded and sealed.

15 Fig. 2B is a perspective and view of the packet according to Fig. 2A with the flap in a partial folded condition.

Fig. 2C is a perspective view of the packet according to Fig. 2B with the flap folded and sealed over the exit structure.

Figs. 3A and 3B are cut-away views of a packet configuration in a folded and opened state.

20 Figs. 4A and 4B are cut-away views of an alternate packet configuration in a folded and opened state.

Fig. 5 is a perspective and partial cut-away view of an alternate embodiment according to the invention.

DETAILED DESCRIPTION OF THE PREFERRED EMBODIMENTS

25 Reference will now be made in detail to one or more embodiments of the invention, examples of which are illustrated in the drawings. The embodiments are provided by way of explanation of the invention, and are not meant as a limitation of the invention. Features illustrated or described as part of one embodiment may be used with another embodiment to yield still a different
30 embodiment. It is thus intended that the present invention include modifications and variations to the embodiments illustrated and described herein.

It should be appreciated that the novel packet according to the invention is not limited to any particular intended use or type of fluid composition stored in the packet.

Referring to the figures in general, various embodiments of a packet 10 are
5 illustrated. In the embodiment of Fig. 1, the packet 10 is depicted as a relatively small, disposable structure designed to store and dispense any desired fluid composition 14. The packet 10 may be any size depending on dose of the fluid composition 14 desired to be delivered with use of the packet 10. As discussed in
10 greater detail below, the packet 10 is sealed by a folded flap 30, and the packet is opened by the user pulling on the flap 30, or a flap extension 32, which causes the flap 30 to unfold and expose exit structure 28 in the packet through which the fluid composition 14 migrates.

As seen in the various figures, the packet 10 defines a cavity 12 in a first portion of the packet, with the fluid composition 14 contained within the cavity 12.
15 The packet 10 may be formed from opposed material layers 16, 18 attached together to define the sealed cavity 12. The opposed layers 16, 18 may be attached by thermal bonding, although any suitable attachment method may be used depending on the type of material selected for the layers 16, 18.

The packet material layers 16, 18 may be made from any suitable flexible
20 material that is impermeable to the fluid composition 14 contained in the cavity 12. The packet materials should have no negative impact on or reaction with the fluid 14. The materials used in the construction of the packet 10 and the fill level of the fluid composition 14 within the cavity 12 create a structure that is durable and flexible, and one that is not easily burst open during normal handling. The packet
25 10 may be formed from the material layers 16, 18 using any conventional attaching techniques, such as adhesives, stitching, welding, heat-sealing, ultrasonic, and so forth. In particular embodiments, the material layers 16, 18 are a heat sealable thermoplastic material, such as a polyethylene or polypropylene film, or other suitable thermoplastics. The layers may also be metallized films. It
30 should be appreciated that the bonding or attaching techniques used to form the packet 10 and associated structure will be a function of the type of materials selected for layers 16, 18.

The packet 10 may include one or more bond points or seals between the opposed layers to define the cavity 12, or other features of the packet. For example, referring to Figs. 1 and 2A, the packet 10 includes seal lines 20 that define a perimeter seal and baffles 22 within the cavity 12, the baffles 22 serving to control flow rate of the fluid composition 14 from the cavity 12. Additional bond lines 24 define a nozzle structure 26 oriented towards the exit structure 28.

Exit structure 28 is provided in a first of the packet material layers, such as layer 16, through which the fluid composition 14 flows in use of the packet 10. Configuration of the exit structure 28 can vary. For example, the structure 28 may comprise any pattern of holes, slits, apertures, or other openings defined completely through the material layer 16. In alternate embodiments, the exit structure 40 may be weakened positions in the packet material or seam structure designed to rupture or burst upon pressure being exerted on the packet. Such weakened positions may be created by embossing, laser scoring, mechanical scoring, or other known methods for weakening a film structure.

The packet 10 incorporates a flap 30 that is formed from an extension of the opposed packet material layers 16, 18 that may be sealed together in a second portion of the packet 10 that is adjacent to the first portion defining the cavity 12, as particularly illustrated in Fig. 2A. As illustrated in Figs. 2A through 2C, the flap 30 may be folded at a first fold line 34 that corresponds to a seal line 25 (Fig. 2A) used to define a longitudinal end of the cavity 12. The flap 30 is folded so as to extend back over the cavity 12 a sufficient distance to cover and releasably seal to the first material layer 16 over the exit structure 28, as particularly seen in Figs. 2B and 2C. The seal 38 (Fig. 3A) between the flap 30 and material layer 32 is designed to be releasable or frangible so that the flap 30 can be subsequently peeled away from the material layer 16 to expose the exit structure 28 without otherwise compromising the packet integrity. For example, a releasable adhesive may be disposed between the flap 30 and material layer 16 for this purpose.

Referring to Fig. 2C, the flap 30 may be folded at a second fold line 36 in an opposite direction so as to extend back over the exit structure 28. This additional

fold may be releasably attached to the first fold at a seal 40 (Fig. 3A) adjacent the second fold line 36, although this is not a necessity.

In particular embodiments of the packet 10, the opposed material layers 16, 18 are thermoplastic materials, such as thermoplastic film layers, heat sealed
5 together along the perimeter seal 20 to define cavity 12, and also baffles 22 and nozzle structure 26 if desired. With thermoplastic materials, the flap 30 may be heat sealed directly to the first material layer 16 over the exit structure 28 in a seal zone 27 (indicated by the dashed lines in Fig. 2A) that circumscribes the exit
10 structure 28. The seal zone 27 may be a border seal around the exit structure 28, or a continuous seal over the area of seal zone 27 that encompasses the exit structure 28, as indicated by the dashed lines in seal zone 27 of Figs. 1 and 2A. For example, the first material layer 16 may have an outer surface layer with heat seal characteristics (i.e. temperature, dwell time, and pressure) different than that of an inner surface layer of the material 16. In this way, the flap 30 may be heat
15 sealed directly against the first material layer 16 at conditions different than that needed to heat seal the opposed material layers 16, 18 together along the perimeter seal. The flap seal may thus be considered weaker or "frangible" as compared to the perimeter seal defining the cavity 12, or other packet structure.

The material layer 16 may be a multi-layered film with different layers
20 having different heat seal characteristics. The layers may be co-extruded or laminated layers, with one of the outer surface layers including a sealant material or coating, such as SURLYN from Dupont, or a blend of polybutylene with ethylene vinyl acetate or ultra low density ethylene copolymers, polyolefin plastomers, or polyethylene. Sealant layers made with these resins or blends
25 provide different seal strengths depending upon seal temperature, dwell time, and pressure as compared to the base polymer material. Thus, the seal between the flap 30 and outer surface of the first material layer 16 can be made selectively frangible as compared to the permanent perimeter seal defining the cavity 12 by varying the sealing conditions. The flap 30 can be heat sealed directly to the
30 material layer 16 over the exit structure 28 without concern of the inner surfaces of the material layers 16, 18 being sealed together within the seal zone 27.

The second material layer 18 may be the same or a different thermoplastic film as compared to the first material layer 16, so long as a seal can be formed with the inner surface of the material layer 16.

5 Various multilayer thermoplastic films are commercially available and may be used to form packets 30 as described herein. For example, a line of multilayer thermoplastic films under the name PERFECFLEX® films are available from Perfecseal, Inc. (a division of Bemis Company, Inc.) having a principal place of business in Oshkosh, Wisconsin, USA. A particularly suitable film from Perfecseal, Inc., is identified as EZ PEEL® Polyethylene Film (product code
10 34466-G). This film is a multilayered PE film having a frangible sealant layer on one outer side of a core layer. For use as material layer 16, this film is oriented so that the frangible sealant layer is outwardly facing and, thus, defines the mating surfaces of the flap 30 and material surface 16 when heat sealing the flap 30 directly to the material 16. The EZ PEEL® film (without corona treatment on the
15 opposite outer side) may also be used as the opposite material layer 18, with the frangible sealant layer of the film outwardly disposed.

The flap 30 may be grasped directly the user to open the packet 10. In alternate embodiments, the flap 30 may include a longitudinally extending tab or extension 32 that presents an element to be grasped by the user to open the
20 packet 10. The extension 32 may take on any desired shape or configuration. When the extension 32 is pulled, the flap 30 is caused to unfold and release from the material layer 16, and thereby uncover the exit structure 28. The fluid composition 14 within the cavity 12 is then free to migrate out of the exit structure 28 in the embodiment wherein the exit structure 28 includes holes or other
25 openings through the packet material. In the embodiment wherein the exit structure 28 includes weakened material portions, the packet is activated by the user applying pressure to the packet (for example, by squeezing the packet) causing the weakened material portions to burst.

Figs. 3A and 3B are cross-sectional views illustrating the folded and opened
30 configuration of a particular embodiment of the packet 10. This embodiment may be made with the EZ PEEL product 34466-G as the material layers 16, 18 with the frangible sealant layer outwardly facing for each material layer. Referring to Fig.

3A, seal 38 represents the heat seal between the flap 30 (folded at fold line 34) and the material layer 16 in a seal zone over the exit structure 27. Seal 40 represents an additional heat seal between folds (defined by fold line 36) of the flap 30 that may be desired to maintain the flap 30 in a compact folded state
5 attached to the packet 10 prior to use of the device. Fig. 3B illustrates the flap 30 after flap extension 32 has been pulled by the user along the direction indicated by the arrow. This action causes the flap seal(s) 38, 40 to peel apart and thus expose the exit structure 28, at which point the fluid composition 14 can exit the cavity 12.

10 It should be appreciated that the seals 38 and 40 may be provided by an adhesive composition disposed between the mating surfaces, particularly in embodiments wherein non-thermoplastic materials are used as packet layers 16, 18, or bonding techniques other than heat sealing are used to construct the packets 10.

15 Figs. 4A and 4B illustrate an embodiment wherein the flap 30 is folded at a second fold line 36 disposed such that the exit structure 28 (with a first fold of flap 30 sealed thereto at seal 38) is folded in an opposite direction so as to lie adjacent to the second material layer 18. This additional fold may be attached to the material layer 18 with a second seal 40. In this configuration, the exit structure 28
20 is isolated from the contents of the cavity by the second fold line 36. In this embodiment, the opposed material layers 16, 18 may be thermoplastic materials heat-sealed together along a perimeter seal defining the cavity 12. The flap 30 is heat sealed directly to the first material layer 16 over the exit structure 28 (as indicated at seal 38) in a seal zone that circumscribes the exit structure 28. The
25 additional fold of the flap 30 is heat sealed directly to the second material layer 18 adjacent the second fold line 36, as indicated by seal 40. The first and second material layers 16, 18 may be multi-layer films having an outer surface with heat seal characteristics such that the flap heat seals 38, 40 are made to be frangible without sealing the inner surfaces of the material layers 16, 18 together.

30 It should be appreciated that any embodiment of a packet 10 according to the invention may be made from various combinations of single and multi-layer films selected to have desired heat seal characteristics for defining the perimeter

seal of the cavity 12, as well as any baffle seals 22 or nozzle seal 24, and the flap seal 38 (and seal 40 if included). With certain combinations of films, care must be taken to prevent the material layers 16, 18 from sealing together and collapsing the cavity 12 at the exit structure 28 when forming the seal 38. In this regard, Fig. 5 illustrates an embodiment wherein material layers 16, 18 may include inner film layers that could seal together at or near the exit structure 28 when forming the flap seal 38. To prevent this situation, an insert material 44 is placed within the cavity 12 prior to sealing the ends of the cavity 12. The insert 44 is positioned so as to underlie the exit structure 28 within the seal zone 27. The insert 44 is made of a material that will not seal with at least the upper material layer 16 when the seal 38 is formed between the flap 30 and material layer 16. The insert 44 may be, for example, a flexible piece of poly material having a higher melt point than material layer 16. The insert 44 thus ensures that the cavity 12 is not collapsed and sealed around the exit structure 28 when forming the flap seal 30. The insert 44 may be a multi-layered film such as a polyester/sealant layer film having a surface adjacent material layer 16 that will not heat seal with layer 16, and an opposite sealant layer surface that will heat seal with material layer 18 within the cavity, thus ensuring that the insert 44 is held in place during the sealing process. It should be appreciated that any type of material or structure may serve as insert 44.

In the embodiment of Fig. 5, the flap extension 32 is simply an extension of the entire flap 30.

The fluid composition 14 contained within the packet 30 may be any fluid suitable for the intended use of the applicator 10, including cleansing fluids for human/animal use and cleaning fluids for cleaning surfaces. The fluid may be any paste, gel, powder, oil, liquid, or any other appropriate medium. Example cleansing fluids include surfactants such as water-soluble polymers, polysorbates, glycerins, glycol-based surfactants, and/or silicone-based surfactants. The fluid may include other materials, such as water, salts, vinegars, humectants, scouring powders, thickening agents, and fragrances. A cleansing fluid may also include a moisturizer that helps to maintain a normal skin hydration level. A cleansing fluid may also include preservatives and other ingredients that do not disrupt the

normal flora of the vaginal area (e.g., sorbic acid, citric acid, methyl paraben, and natural preservatives such as grapefruit extract). The fluid may include other materials that may be applied to an area of the body. Example materials include lubricants, deodorants, and other inactive or active ingredients (e.g., spermicidal agent or medication). In one aspect of the present invention, the fluid is a cleansing fluid that is primarily a water-based solution (90%+ water content) with a surfactant, preservatives, pH neutralizers, and a thickening agent.

The fluid may be a cleaning solution such as FOUR PAWS Super Strength Stain and Odor Remover, which includes water, natural enzymes, and mild detergent (from Four Paws Products, Ltd., Hauppauge, N.Y.), or NATURE'S MIRACLE Stain & Odor Remover, which includes water, natural enzymes, isopropyl alcohol, and natural citrus scent (from Pets 'N People, Inc., Rolling Hills Estates, CA), or RESOLVE Carpet Spot & Stain Carpet Cleaner (from Reckitt Benckiser, Wayne, NJ). The fluid may be a pet shampoo. The fluid may be a stain cleaner and stain guard such as SCOTCHGARD Oxy Carpet Cleaner with Stain Protector that includes water, 2-butoxyethanol, hydrogen peroxide, and surfactants (from 3M Corporation, St. Paul, MN). In the case of using the cleaning device 10 to clean a fabric surface, the fluid may include a pet repellent such as SIMPLE SOLUTION Indoor/Outdoor Repellent for Dogs and Cats, which has as an active ingredient methyl nonyl ketone (from The Bramton Company, Dallas, TX).

The fluid may be an antimicrobial. Examples of suitable antimicrobials include quaternary ammonium compounds such as 3-trimethoxysilylpropyldimethyloctadecyl ammonium chloride (AEGIS); poly cationic chemicals such as biguanides (poly (hexamethylene) biguanide hydrochloride (PHMB) Arch Chemical), 2, 4, 4'-Trichloro-2' - hydroxyl-dipenylether (Tinosan, Ciba); diphenyl ether (bis-phenyl) derivatives known as either 2, 4, 4'-trichloro-2' hydroxy dipenyl ether or 5-chloro-2-(2, 4-dichlorophenoxy) phenol; triclosan; silver; and copper. The fluid may be an allergen sequester that may be a charged or mixed charged particle or nanoparticle. Most allergy proteins are glycoproteins (proteins that contain covalently-bound oligosaccharides), so a negative charge may be better than predominance of positive charges on the

particles, although mixed charges may be preferred. Clays or modified clays work in this respect. Examples of suitable allergen sequestrates include plant lectins with an affinity for N-acetylgalactosamine such as jacalin, peanut, and soybean, where the lectins both bind allergens and are bound to the web, thus removing
5 allergens from a surface. The fluid may also include a fragrance. The fluid may also include a pheromone to either attract or repel an animal. The fluid may also be shoe polish, a carpet cleaning solution, a stain removal fluid, kitchen floor and counter top cleaners, etc.

Embodiments of the invention have been described with reference to
10 various specific and illustrative aspects and techniques. However, it should be understood that many variations and modifications may be made while remaining within the spirit and scope. Accordingly, this is intended to embrace all such alternatives, modifications and variations that fall within the spirit and scope of the appended claims.

WHAT IS CLAIMED IS:

1. A pull activated packet for storing and dispensing any manner of fluid composition,

opposed first and second material layers sealed together along a perimeter defining a sealed cavity between said opposed layers, and a fluid composition contained within said cavity;

exit structure defined in said first material layer through which said composition exits said cavity in use of said packet;

a flap defined by a portion of said opposed layers folded at a first fold line so as to extend over and releasably seal to said first material layer over said exit structure, said first fold line defined along a portion of said sealed perimeter that delimits said cavity such that said composition is not contained in said flap;

wherein to open said packet, said flap is pulled by a user causing said flap to peel away from said first material layer and unseal from said exit structure, whereby said fluid composition is dispensed from said exit structure upon pressure being applied to said packet; and

wherein said flap is folded at a second fold line disposed such that said exit structure is folded adjacent said second material layer and is isolated from said cavity by said second fold line.

2. The packet as in claim 1, wherein said flap is releasably sealed to said second material layer adjacent said second fold line.

3. The packet as in claim 2, wherein said opposed material layers comprise thermoplastic materials heat sealed together along a perimeter seal defining said cavity, said flap heat sealed directly to said first material layer over said exit structure in a seal zone that circumscribes said exit structure, and said flap heat sealed directly to said second material layer adjacent said second fold line.

4. The packet as in claim 3, wherein said first and second material layers comprise an outer surface with characteristics different than an inner surface of said first and second material layers such that said flap heat seals against said first

and second material layers in a frangible heat seal as compared to said perimeter seal.

5. The packet as in claim 4, wherein said first and second material layers comprise multi-layered films having an outer sealant layer with characteristics suitable for forming said frangible heat seals with said flap.

6. A pull activated packet for storing and dispensing any manner of fluid composition, opposed first and second material layers sealed together along a perimeter defining a sealed cavity between said opposed layers, and a fluid composition contained within said cavity;

exit structure defined in said first material layer through which said composition exits said cavity in use of said packet;

a flap defined by a portion of said opposed layers folded at a first fold line so as to extend over and releasably seal to said first material layer over said exit structure, said first fold line defined along a portion of said sealed perimeter that delimits said cavity such that said composition is not contained in said flap;

wherein to open said packet, said flap is pulled by a user causing said flap to peel away from said first material layer and unseal from said exit structure, whereby said fluid composition is dispensed from said exit structure upon pressure being applied to said packet; and

wherein said first and second opposed material layers comprise thermoplastic materials heat sealed together along a perimeter seal defining said cavity, said flap heat sealed directly to said first material layer over said exit structure in a seal zone that circumscribes said exit structure, and further comprising an insert within said cavity disposed to prevent said first and second material layers from sealing together in said seal zone upon heat sealing said flap to said first material layer.

7. The packet as in claim 1, further comprising baffles within said packet cavity.

2006285331 04 May 2011

8. The packet as in claim 7, wherein said baffles comprise seal lines between said opposed first and second material layers of said packet.

9. The packet as in claim 1, wherein said fluid composition comprises a medicinal product.

10. The packet as in claim 1, wherein said fluid composition comprises a food product.

11. The packet as in claim 1, wherein said fluid composition comprises a cleaning product.

12. The packet as in claim 1, wherein said flap further comprises a flap extension having a shape and configuration so as to be grasped by a user to pull said flap away from said first material layer.

13. A pull activated packet substantially as hereinbefore described with reference to any one of the embodiments illustrated in the accompanying drawings.

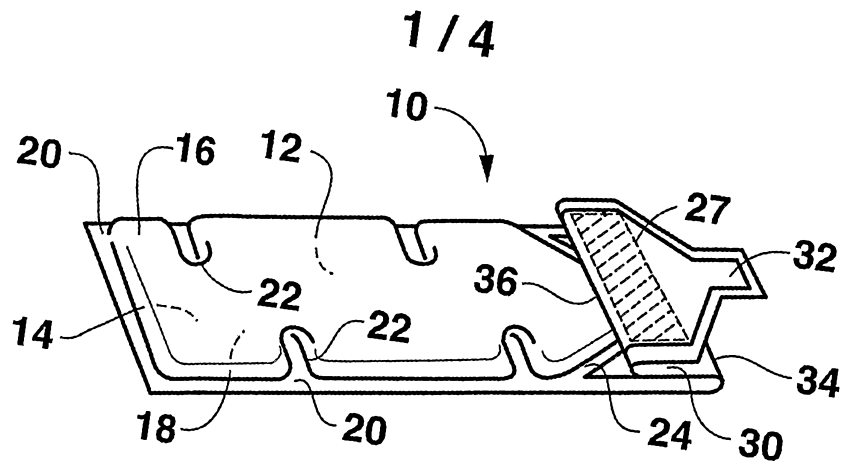

FIG. 1

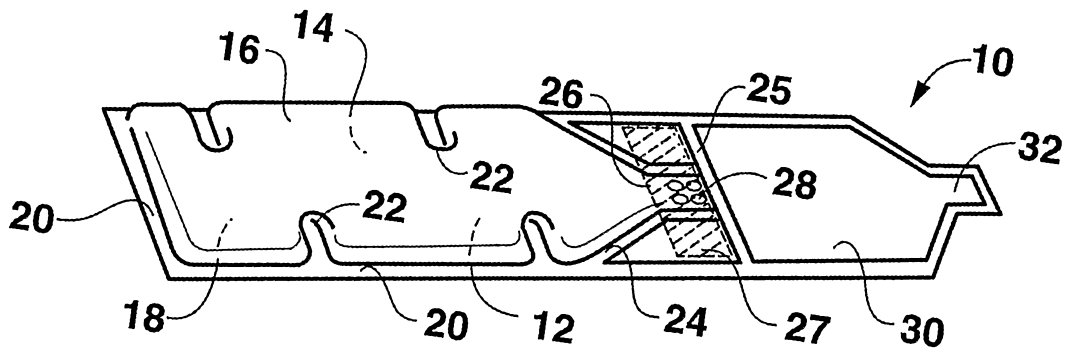

FIG. 2A

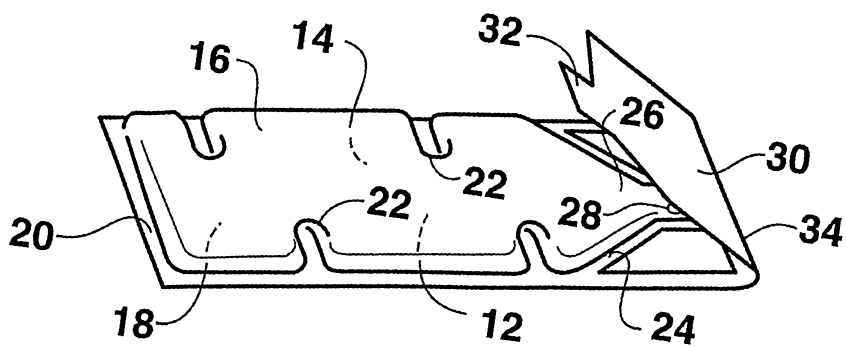

FIG. 2B

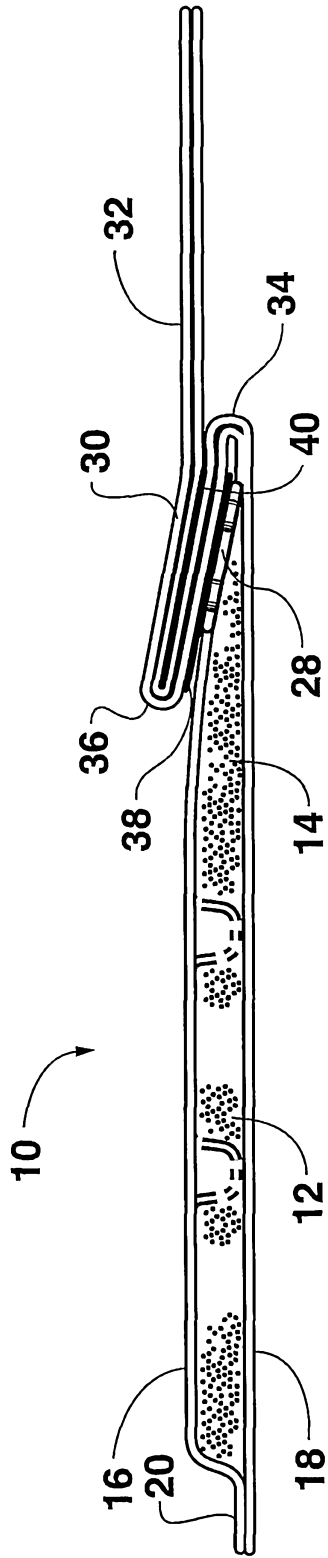

FIG. 3A

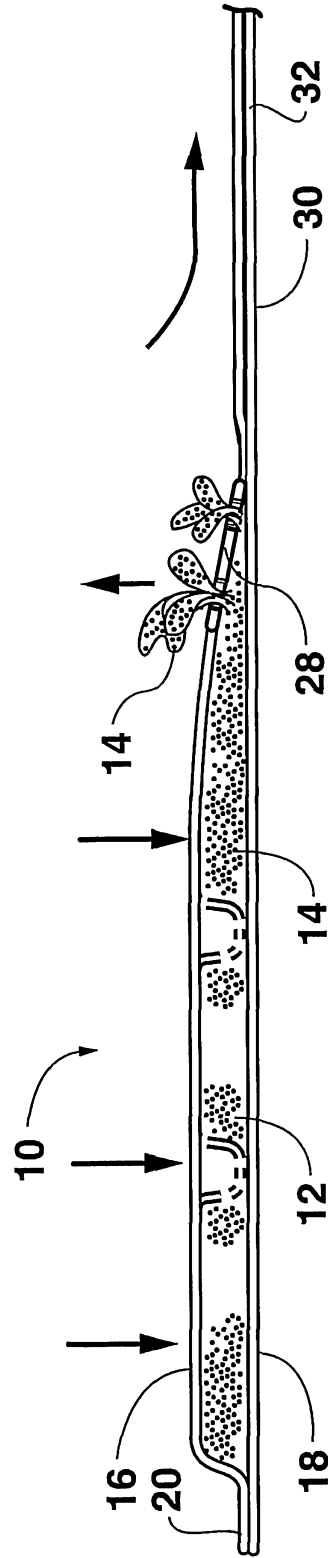

FIG. 3B

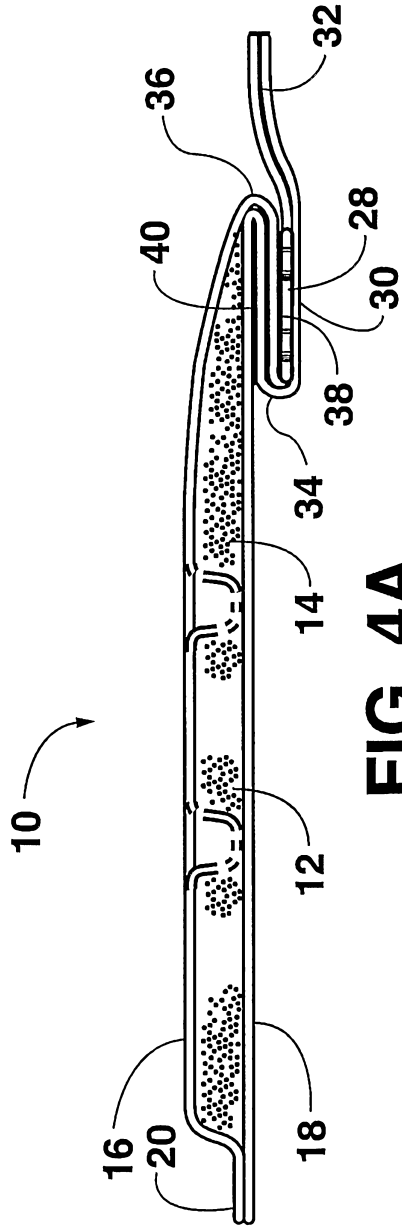

FIG. 4A

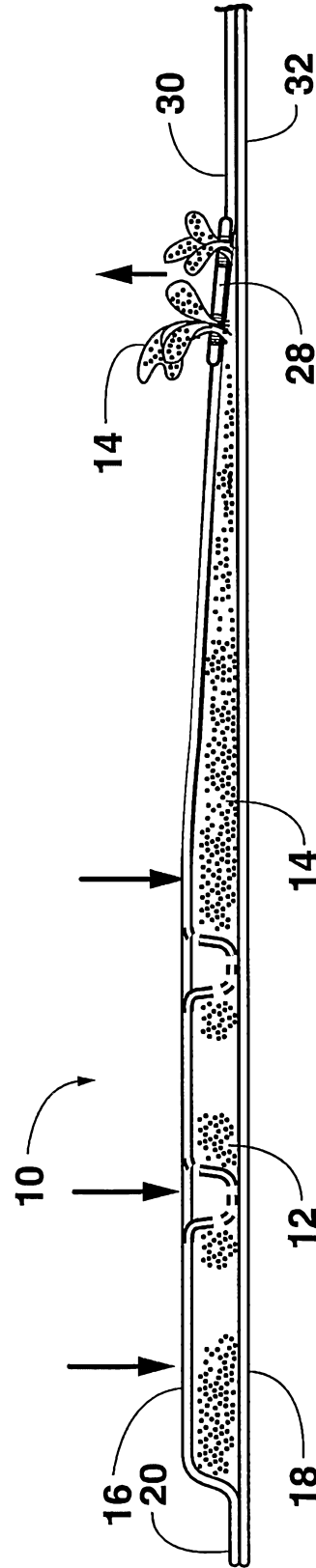

FIG. 4B