

Jan. 2, 1968

H. FLEISSNER

3,360,872

SIEVE DRUM DRYERS

Filed Aug. 10, 1966

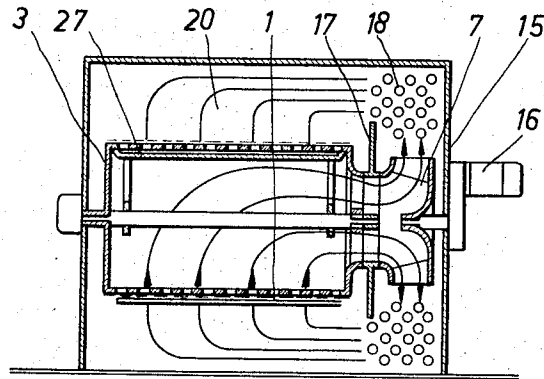

Fig. 1

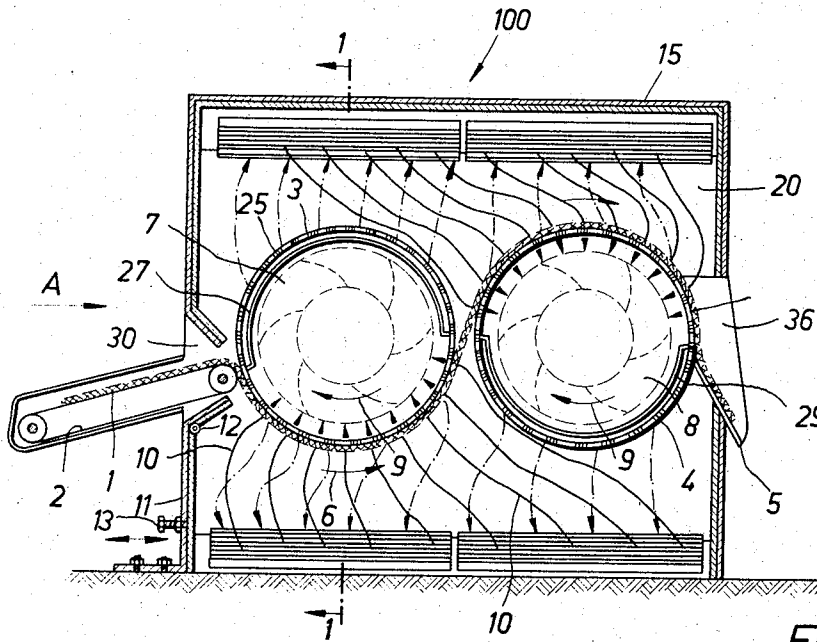

Fig. 2

Inventor:

HANS FLEISSNER

By *McGraw and Toren*
ATTORNEYS

1

2

3,360,872

SIEVE DRUM DRYERS

Hans Fleissner, Egelsbach, Frankfurt am Main, Germany, assignor to Firma Establishment for Automation, Vaduz, Liechtenstein

Filed Aug. 10, 1966, Ser. No. 571,517

Claims priority, application Switzerland, June 19, 1962, 7,328/62

6 Claims. (Cl. 34—115)

This application is a continuation-in-part of my co-pending application Ser. No. 288,753, filed June 18, 1963, now abandoned.

This invention generally relates to sieve drum dryers and is particularly concerned with an improved construction for guiding and conducting the air flow in such dryers in a particularly advantageous and efficient manner.

In the customary sieve drum drying apparatus, at least two sieve drums are rotatably arranged adjacent each other in a casing defining a drying chamber. The casing has an inlet side and a discharge side. Material to be dried within the dryer is introduced through the inlet side and travels over the exterior surfaces of the adjacently arranged drums in a wave-like pattern, that is the material, for example textile webs, travels first over one-half of the rotating drum adjacent the inlet, is fed into the nip between this and the next adjacent drum, and continues its passage through the dryer on the exterior of the other half of the next adjacent drum and so on until the material is discharged through the discharge side. The material to be dried in this type of dryer is held on the drum exterior by means of suction which is created within the drum interior. This is usually accomplished by radial fans within the drums which are coaxially mounted on the drive shafts of the respective drums. Due to the sub-atmospheric pressure conditions prevailing within the drum interior, the material traveling over the drum is not only urged thereagainst and held thereon but large quantities of air are sucked through the material, the amount of air passing through the material being dependent on the air permeability of the material. In order to maintain the subatmospheric conditions within the drum interior, the perforations of that portion of the respective drums which is not covered by material are usually blocked by baffles or cover plates which prevent air from entering the interior through the perforations of the respective drums at such portion.

As previously mentioned, the subatmospheric pressure conditions within the drum interior cause air to be sucked through the material at great speed. This high velocity air tends to form eddies, cross-currents and turbulence. These turbulent flow phenomena constitute a flow component not only in radial direction of the drum but also in axial and tangential directions at the sieve drum circumference. These turbulent cross flows, therefore, tend to dislodge the material from the drum surfaces, causing interruption in the operation or at least unsatisfactory drying.

It is a primary object of this invention to overcome the disadvantages of the prior art sieve drum constructions by providing means for effectively preventing undesired turbulent flow conditions acting axially or tangentially on the material on the sieve drum.

It is also an object of this invention to provide an improved air flow guiding system for use in drum dryers of the kind referred to.

Generally, it is an object of this invention to improve on drum dryer constructions as presently available.

The term "air" as used herein is not limited to air proper but includes other gaseous media used for drying material in drum dryers.

Briefly, and in accordance with this invention, the fan located coaxially and exteriorly of the first sieve drum, i.e. the drum adjacent the inlet, over which the material to be dried travels, is rotated in a direction opposite to the rotational direction of that sieve drum. It has surprisingly been established that rotation of the fan in a direction opposite to the rotational direction of the first sieve drum results in a number of important advantages. Due to this arrangement, the air outside the drum is first moved for a short period in a direction opposite to the direction of movement of the material. Thereafter, the air flow is deflected in the vicinity of the sieve drum jacket to flow through the material in radial direction. This is accomplished by the uniform suction force which acts in the region of the drum circumference. Due to the radial flow of the air through the material, the material is subjected to a motion component which acts in the rotational direction of the sieve drum. With a view to supplying the air to the drum in a substantially radial flow direction at least in the vicinity of the sieve drum circumference, the casing of the dryer is provided at the inlet side with an end wall or baffle which extends and may be adjusted or positioned in a suitable manner. This baffle prevents substantial deviation of the air from the radial flow direction relative to the rotational movement of the material. The air is thus sucked through the pores of the material and the perforations of the drum in radial direction. This end wall or baffle is preferably adjustable toward all directions relative to the sieve drum so as suitably to influence and confine the air flow. In this manner, the motion component in the direction of movement of the material can be adjusted to any desired degree.

The inventive construction distinguishes over the prior art constructions because, in the prior art constructions, in which the fan and the drum rotate unidirectionally, the air or the like gaseous medium is first sucked away from below the subsequent sieve drum surface which is not covered by the material to be dried. The supply of air to the first sieve drum thus emanates in the prior art constructions to a large extent from the subsequent sieve drum, which results in the disadvantages previously referred to.

According to a modification of the invention, the fans arranged coaxially and exteriorly of the subsequent sieve drums may all rotate in a direction opposite to that of the respective drum. It should be realized, however, that the rotational movement of the fan of the first drum is decisive also for the air flow passing through the material on the subsequent drums. Therefore, the inventive arrangement according to which the fan of the first drum rotates in a direction opposite to that of the drum significantly influences a favorable air flow through the subsequent drums even if the fans of the subsequent drums rotate in the same direction as the drums.

It is also feasible to alternate the arrangement and to have the fan of the second drum rotate in the same direction as the associated drum while the fan of the third drum again rotates in an opposite direction.

The invention significantly improves the output of sieve dryers of this kind due to the improved air flow with resulting increased drying capacity and more secure adherence of the material on the drum exteriors. In addition, the inventive system enables control of the air flow within wide limits, due to the arrangement of the adjustable baffle plate at the inlet side of the drying chamber.

It should be realized that the material to be dried is, of course, the heaviest when it starts wrapping around the first drum so that the control of the air flow with regard to the first drum is more critical than with regard to the subsequent drums. Undesired turbulence or cross flow con-

3

ditions of the air at the first drum negatively affect the travel of the material through the dryer.

The various features of novelty which characterize the invention are pointed out with particularity in the claims annexed to and forming a part of this specification. For a better understanding of the invention, its operating advantages and specific objects attained by its use, reference should be had to the accompanying drawings in which there is illustrated and described a preferred embodiment of the invention.

In the drawings:

FIG. 1 is a longitudinal sectional view through a drum dryer embodying the invention, taken on the line 1—1 of FIG. 2; and

FIG. 2 is a transverse sectional view of the drum dryer looking from the left of FIG. 1.

Referring now to the drawing, the drum dryer generally indicated by reference numeral 100 comprises a casing 15 defining an interior chamber 20. Sieve drums 3 and 4 are mounted adjacent each other for rotation within the chamber 20. The drums 3 and 4 are perforated as seen at 25. The upper half of the drum 3, as seen in the drawing, has an interior baffle plate 27 blocking the perforations while a corresponding plate 29 is arranged to cover the perforations of the lower half of drum 4. Fans 7 and 8 are respectively coaxially arranged exteriorly of the drums 3 and 4.

The material to be dried which may, for example, be a wet web of textile material 1, is introduced through the inlet 30. In order to facilitate the feeding of the web 1, an endless conveyor belt 2 is arranged adjacent the inlet 30. The web now travels over the lower exterior portion of drum 3 into the nip between drums 3 and 4 and over the upper exterior surface of drum 4, whereafter the web is discharged through the discharge end 36. In order to facilitate the discharge, a chute or slide member 5 is provided, as indicated in the drawing. Generally, the travel direction of the web through the dryer is indicated by arrow A. The rotational direction of the drums is indicated by the arrows 6.

In accordance with this invention, the fan 7 which is coaxially arranged exteriorly of the first drum 3, rotates in a direction opposite to the rotational direction of drum 3. This is clearly apparent by the arrow 9 which indicates the rotational direction of fan 7 as distinguished from the arrow 6 which indicates the rotational direction of drum 3.

In the embodiment shown, fan 8 coaxially arranged exteriorly of drum 4 also rotates in a direction opposite to the rotational direction of drum 4, as indicated by arrow 9'. The opposite rotation of the drums and fans, respectively, results in an air flow as indicated by the arrows 10. Thus, it will be noted that the air is first urged in a direction opposed to the rotational direction of the drum whereafter, due to the suction created within the drum interior, the air is deflected and passes radially through the material into the drum.

According to a further feature of the invention, the inlet side of the casing 15 is provided with an end plate or baffle 11 which is adjustable in any desired direction. Wall portion 11 is provided with an adjustable portion which is adjustable about a hinge 12, and is further provided with a bolt adjustment means 13 by means of which its position may be adjusted as indicated by the double headed arrow. By virtue of the adjustment of baffle 11, including the adjustment of the under portion thereof about the hinge 12, the distance from the baffle to the first drum 3 is variable, as well as the angle which its

4

upper part, pivotable about pivot 12, includes with the vertical plane.

The driving means for drum 3 and the fan 7 is indicated 16 in FIG. 1, drum 3 being driven through member 17 independently of fan 7. Also referring to FIG. 1, it will be noted that the air discharged radially from fan 7 exits from casing 15 through perforations or apertures 18.

The inventive construction has the particular advantage that also loosely united materials which generally can be maintained only with difficulty on the lower half of the drums, can be dried effectively without being blown off from the drums. The radial flow of the air through the perforations into the interior of the drums effectively retains even strands of material on the surface of the drums.

While a specific embodiment of the invention has been shown and described in detail to illustrate the application of the inventive principles, it will be understood that this invention may be embodied otherwise without departing from such principles.

What is claimed is:

1. A drying device comprising a housing defining a drying chamber, at least two perforated drums rotatably mounted within said chamber in adjacent parallel relation, at least two fans rotatably mounted within said chamber, each coaxial with a respective drum and positioned exteriorly of one axial end of the associated drum, each fan moving air inwardly through the perforations of its associated drum and axially through the interior thereof for discharge exteriorly of the associated drum, the material to be dried traveling over the perforated exterior drum surfaces and being held thereon by suction generated within the drum interiors by the associated fans, and driving means connected to said drums and to the associated fans to rotate the same, said driving means rotating at least the first drum over which the material travels, and its associated fan, in opposite angular directions.

2. The improvement of claim 1, wherein said housing has an inlet side and a discharge side, and including an adjustable wall member mounted on said inlet side adjacent said first drum and adjustable relative to said first drum.

3. A drying device as claimed in claim 1, wherein said housing has an inlet side and a discharge side, the fan associated with said first drum rotating in a direction opposite to the direction of travel of material entering through said inlet side, passing over said drum and exiting through said discharge side.

4. A drying device as claimed in claim 3, wherein said driving means rotates each drum and its associated fan in opposite angular directions.

5. A drying device, as claimed in claim 3, wherein said driving means rotates all of said fans in the same angular direction.

6. A drying device, as claimed in claim 2, wherein said wall member includes a wall portion angularly adjustable relative to the remainder of said wall member about a horizontal axis and relative to said first drum.

References Cited

FOREIGN PATENTS

1,314,360 12/1962 France.

FREDERICK L. MATTESON, Jr., *Primary Examiner*.
JOHN J. CAMBY, *Assistant Examiner*.