

Sept. 29, 1925.

1,555,005

O. GÜNTHER  
STEAM VALVE FOR BOILERS  
Filed July 13, 1923

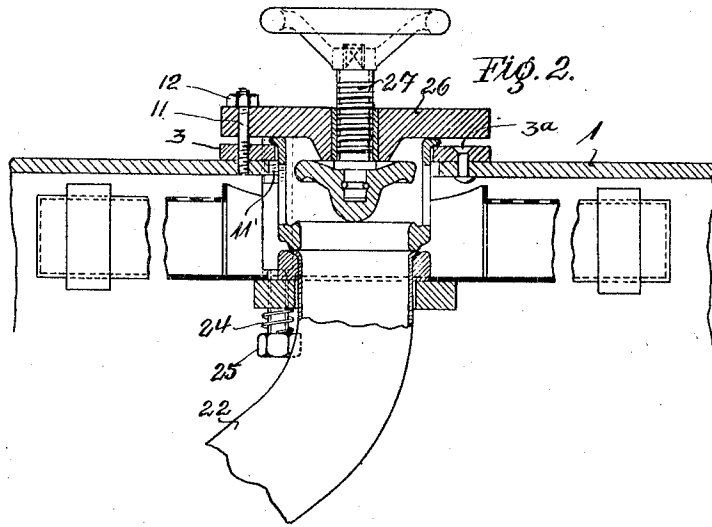
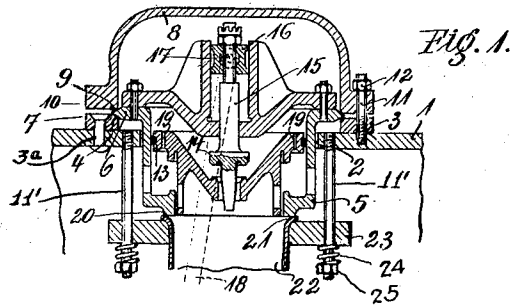

INVENTOR  
OTTO GÜNTHER

BY

*Oskar Heberich*  
ATTORNEYS

# UNITED STATES PATENT OFFICE.

OTTO GÜNTHER, OF ESSLINGEN, GERMANY, ASSIGNOR TO THE SUPERHEATER COMPANY, OF NEW YORK, N. Y., A CORPORATION OF DELAWARE.

## STEAM VALVE FOR BOILERS.

Application filed July 13, 1923. Serial No. 651,211.

*To all whom it may concern:*

Be it known that I, OTTO GÜNTHER, a citizen of the German Empire, and resident of Esslingen a.N., Germany, have invented certain new and useful Improvements in Steam Valves for Boilers, of which the following is a specification.

My invention relates to the fitting of valves in boilers particularly of steam supply valves and stop valves for the steam pipes in locomotives connecting the boiler with the cylinders. The purpose of the invention is to fasten the valves in a way, that they are easily accessible and may be easily repaired by withdrawing the valve together with its casing from the boiler.

It is known for facilitating repair to screw a head or cap of a valve into the casing of a valve fixed to two pipes, the valve breaking and opening the connection between the two pipes.

My invention consists primarily in fixing the valve casing to a zone of the boiler shell plate surrounding an opening in the plate through which the valve casing is introduced into the interior of the boiler.

In the second place my invention refers to the joining or fitting of the valve case to the orifice formed by the open end of the steam supply pipe for the cylinders.

Steam supply valves and stop valves of locomotives have been fastened heretofore to supports inside the steam dome and rendered accessible by a manhole or the like, which had to be of a considerable and very inconvenient size. Valves according to the invention may be fastened from the outside either in the dome or somewhere else in the boiler.

Fig. 1 shows a section through an embodiment of my invention applied to a steam supply valve,

Fig. 2 shows a steam stop valve in section.

Referring to Figure 1, 1 is the boiler shell plate, 2 an opening provided in it, 3 a supporting and strengthening ring tightly fixed to the shell plate as by the rivets 3<sup>a</sup> and having a bevelled edge 4, which is finely ground. 5 is the valve casing provided with a flange 6 having a conical or tapering finely ground outer edge 7. 8 is a cap or cover provided with a bevelled finely ground edge 9 and a flange 10. 11 are screw bolts tightly fixed in the boiler plate, 12 are nuts, by which the conical edge of the flange 6 is

tightly pressed on the ring 4 and the edge 9 of the cap 8.

The supply valve itself is of a known structure. The valve body is a piston valve sliding with its packing ring 13 at its upper part in the upper part of the casing 5 and with its lower part in the lower part of the casing. 14 is a by pass valve actuated with its stem 15 by means consisting of a square 16, pivots 17 and rod 18, the motion of which is controlled in a well known manner by a hand lever (not shown). 19 are small holes connecting the spaces below and above the valve body.

It is evident that by loosening the nuts 12 the valve casing 5 may be easily removed from the boiler together with the supply valve, after the pivots 17 have been withdrawn.

The finely ground bottom surface 20 of the valve casing 5 fits tightly to the open finely ground and flanged end 21 of the steam supply pipe 22. The tightening pressure is exerted by means of a ring 23 pressed to the flanged end of the pipe 22, by springs 24 and the nuts 25 screwed on the lower threading of the bolts 11'.

The steam stop valve shown in Fig. 2 shows the same features as to fastening the valve casing to the boiler shell plate.

Instead of the cap 8 there is a cover or closing plate 26 in which the screw-threaded stem 27 is mounted and tightened in a well known manner.

What I claim as my invention is the following.

1. In the combination of a boiler and a steam valve, a valve casing extending into the boiler and provided with an outwardly projecting flange exteriorly of the boiler shell, a support for the said flange around an opening in the boiler shell plate, a cover closing the valve casing at its upper side, means adapted to be actuated from the outside of the boiler to press said cover on the said flange and said flange on the said support to fasten the valve casing to the boiler shell and to make a tight joint between the said support, flange and cover.

2. In a device as claimed in claim one, the means to make a tight joint including finely ground surfaces on the said support, flange and cover.

3. In a device as claimed in claim one, the means to fasten the valve casing includ-

ing screw bolts fastened to the boiler shell plate, and nuts adapted to press the cover on the said flange and its support.

4. In combination with a device as claimed in claim 1, a steam supply valve, a by-pass valve provided with a stem mounted in said steam supply valve, the cover being of cap shape and enclosing the upper end of said stem, and a controlling member connected with said stem.

5. In a device as claimed in claim one, the support for the flange of the valve casing consisting of a ring having a finely ground surface and tightly fixed to the boiler shell plate.

6. A device as claimed in claim one in combination with a steam supply pipe and means to make a tight joint between the bottom side of the valve casing and the end of the steam supply pipe, when the valve casing is fastened to the boiler shell plate.

7. A device as claimed in claim one in combination with a steam supply pipe and means to make a tight joint between the bottom side of the valve casing and the end of the steam supply pipe, when the valve casing is fastened to the boiler shell plate, said last named means comprising an out-

ward flange at the pipe end, a ring fitting underneath said flange, a bottom surface of the valve casing corresponding to the shape of said flange and means to press said surface and said flange against each other, when the valve casing is fastened to the boiler shell plate.

8. A device as claimed in claim one in combination with a steam supply pipe and means to make a tight joint between the bottom side of the valve casing and the end of the steam supply pipe, when the valve casing is fastened to the boiler shell plate, said last named means comprising an outward flange at the pipe end, a ring fitting underneath said flange, a bottom surface of the valve casing corresponding to the shape of said flange and means to press said surface and said flange against each other, consisting of bolts fixed to the boiler shell plate, heads at the lower end of said bolts and springs interposed between said heads and the ring fitting underneath said flange.

In testimony, that I claim the foregoing as my invention, I have signed my name, the 20th day of June 1923.

OTTO GÜNTHER.