



## INTERNATIONAL APPLICATION PUBLISHED UNDER THE PATENT COOPERATION TREATY (PCT)

<b>(51) International Patent Classification <sup>5</sup> :</b>  <b>G01N 33/543, 33/58, C12Q 1/68</b>	<b>A1</b>	<b>(11) International Publication Number:</b> <b>WO 93/08472</b>  <b>(43) International Publication Date:</b> 29 April 1993 (29.04.93)
<b>(21) International Application Number:</b> PCT/GB92/01892 <b>(22) International Filing Date:</b> 15 October 1992 (15.10.92)  <b>(30) Priority data:</b> 9121873.5                      15 October 1991 (15.10.91)    GB 9221094.7                      7 October 1992 (07.10.92)    GB  <b>(71) Applicant (for all designated States except US):</b> MULTI-LYTE LIMITED [GB/GB]; M.J. Ventham & Co., Kingsbourne House, 229-231 High Holborn, London WC1V 7DA (GB).  <b>(72) Inventors; and</b> <b>(75) Inventors/Applicants (for US only) :</b> EKINS, Roger, Philip [GB/GB]; CHU, Frederick, Woodnam [GB/GB]; Department of Molecular Endocrinology, University College and Middlesex School of Medicine, Mortimer Street, London WIN 8AA (GB).		<b>(74) Agent:</b> HALE, Stephen, Geoffrey; J.Y. & G.W. Johnson, Furnival House, 14-18 High Holborn, London WC1V 6DE (GB).  <b>(81) Designated States:</b> AT, AU, BB, BG, BR, CA, CH, CS, DE, DK, ES, FI, GB, HU, JP, KP, KR, LK, LU, MG, MN, MW, NL, NO, PL, RO, RU, SD, SE, UA, US, European patent (AT, BE, CH, DE, DK, ES, FR, GB, GR, IE, IT, LU, MC, NL, SE), OAPI patent (BF, BJ, CF, CG, CI, CM, GA, GN, ML, MR, SN, TD, TG).  <b>Published</b> <i>With international search report.            Before the expiration of the time limit for amending the claims and to be republished in the event of the receipt of amendments.</i>
<b>(54) Title:</b> BINDING ASSAY EMPLOYING LABELLED REAGENT		
<b>(57) Abstract</b>  <p>A binding assay process for an analyte, in which process a capture binding agent having binding sites specific for the analyte and a developing binding material capable of binding with the bound analyte or with the binding sites on the capture binding agent occupied by the bound analyte or with the binding sites remaining unoccupied on the capture binding agent are used, employs the capture binding agent in an amount such that only an insignificant fraction of the analyte in the sample becomes bound to the capture binding agent, the capture binding agent preferably being present at high surface density on microspots. A label is used in the assay in relation to the developing binding material, the label being provided by microspheres having a size of less than 5 <math>\mu\text{m}</math> and carrying a marker, preferably fluorescent dye molecules contained within the microspheres. For determination of the concentration of the analyte in the sample the strength of the signal is representative of the fractional occupancy of the binding sites on the capture binding agent by the analyte and a comparison is made with a dose-response curve computed from standard samples. For detection of an analyte comprising a single-stranded DNA sequence the presence of the analyte is detected by the existence of a signal. A kit for the process comprises a solid support having the capture binding agent immobilised on it, a developing reagent comprising the developing binding material attached to the microspheres and, where concentrations are to be measured, standards having known amounts or concentrations of the analyte to be determined.</p>		

*FOR THE PURPOSES OF INFORMATION ONLY*

Codes used to identify States party to the PCT on the front pages of pamphlets publishing international applications under the PCT.

AT	Austria	FR	France	MR	Mauritania
AU	Australia	GA	Gabon	MW	Malawi
BB	Barbados	GB	United Kingdom	NL	Netherlands
BE	Belgium	GN	Guinea	NO	Norway
BF	Burkina Faso	GR	Greece	NZ	New Zealand
BG	Bulgaria	HU	Hungary	PL	Poland
BJ	Benin	IE	Ireland	PT	Portugal
BR	Brazil	IT	Italy	RO	Romania
CA	Canada	JP	Japan	RU	Russian Federation
CF	Central African Republic	KP	Democratic People's Republic of Korea	SD	Sudan
CG	Congo	KR	Republic of Korea	SE	Sweden
CH	Switzerland	LI	Liechtenstein	SK	Slovak Republic
CI	Côte d'Ivoire	LK	Sri Lanka	SN	Senegal
CM	Cameroon	LU	Luxembourg	SU	Soviet Union
CS	Czechoslovakia	MC	Monaco	TD	Chad
CZ	Czech Republic	MG	Madagascar	TG	Togo
DE	Germany	ML	Mali	UA	Ukraine
DK	Denmark	MN	Mongolia	US	United States of America
ES	Spain			VN	Viet Nam
FI	Finland				

Binding assay employing labelled reagentField of the invention

The present invention relates to binding assays employing a labelled reagent. Binding assays include 5 immunoassays for the determination of concentrations of antigens in liquid samples, and it is also possible to use the present invention for the determination or detection of other analytes in liquid samples, including DNA sequences.

The present invention has particular relevance to non-10 competitive sandwich assays, that is to say assays in which a liquid sample containing an antigen or other analyte to be assayed such as a hormone is contacted with a first binding agent (such as an antibody) having binding sites on its molecule specific for the analyte whereby a fraction of the 15 binding sites on the first binding agent representative of the concentration of the analyte in the liquid sample are occupied by the analyte. The fractional occupancy of the binding sites is then determined by a back-titration technique involving the use of a second binding material 20 which is capable of binding with the bound analyte or with the binding sites occupied by bound analyte but not with unoccupied binding sites. Conveniently, the first binding agent will be referred to hereinafter as the capture binding agent and the second binding material will be referred to 25 hereinafter as the developing binding material.

Non-competitive assays are to be distinguished from competitive assays in which the back-titration technique involves the use of a developing binding material which competes with the analyte for the binding sites on the 30 capture binding agent, for example a labelled version of the analyte or another material able to bind with the unoccupied binding sites on the capture binding agent, although the present invention can also be used in such assays. In each case the extent of binding of the developing binding

- 2 -

material is determined by the labelling of the developing binding material (or both that material and the capture binding agent), for example with a fluorescent label, and comparing the strength of the signal emitted by the bound 5 labelled product of analyte bound to capture binding agent and developing binding material in the case of the unknown sample with the signal strengths achieved with corresponding samples of known analyte concentration which together provide a dose-response curve. One type of non-competitive 10 sandwich assay involves the use of a labelled developing binding material and an immobilised capture binding agent which may or may not be labelled.

#### Background Art

It is now well-recognised that non-competitive 15 sandwich immunoassays generally display higher sensitivity than the more conventional competitive immunoassays. The widely accepted explanation for this higher sensitivity is the use of relatively large amounts both of the immobilised capture binding agent (usually an antibody located on a 20 solid support) and of the labelled developing binding material (also often an antibody). By using large amounts of the antibodies, especially the capture antibody, the rate of reaction between analyte and capture antibody is increased, implying in accordance with the law of mass 25 action that a greater amount of analyte is captured on the solid phase capture antibody in any specified time interval. Thus, the use of large amounts of capture antibody is generally perceived as crucial to the development of non-competitive immunoassays combining very high sensitivity 30 with relatively short incubation times. (See for example Hay et al. "American Thyroid Association Assessment of Current Free Thyroid Hormone and Thyrotropin Measurements and Guidelines for Future Clinical Assays" in Clinical Chemistry, Vol 37, No. 11, (1991) at pages 2002-2008.) This 35 approach nevertheless carries disadvantages. For example, it implies heavy consumption of antibodies which may be

- 3 -

scarce and costly to produce. It also involves the use of various stratagems to maximise the total surface area of the solid support on which the capture antibody is deposited. For example, porous glass microspheres have been used as a solid support in sandwich assay systems, the pores greatly increasing the surface area available for antibody attachment.

Roger Ekins has previously argued, for example in WO-84/01031, WO-88/01058 and WO-89/01157, that this general perception is mistaken and that, in certain circumstances, assays which have an even greater sensitivity than that attainable under the conditions mentioned above can be developed when the unknown sample and standard samples containing the analyte are each contacted with such a small amount of the capture binding agent that only an insignificant fraction of the analyte becomes bound to the capture binding agent. (This insignificant fraction is usually less than 5% and ideally 1-2% or less of the total amount of the analyte in the sample, bearing in mind that errors in analyte determination unavoidably introduced into the measuring procedure elsewhere by limitations in the accuracy of sample and reagent manipulation, signal measurements, standardisation, temperature variation and the like are generally of the order of 10% of the analyte in the sample, although sometimes the binding of higher fractions of the analyte up to 10% or so may be tolerated when exact determination is less important.) Only when an insignificant fraction of the total amount of analyte becomes bound is the fractional occupancy  $F$  of the binding sites on the capture binding agent related to the concentration  $[A]$  of analyte in the sample (at thermodynamic equilibrium) by the equation

$$F = \frac{K[A]}{1 + K[A]}$$

where  $K$  is the affinity constant of the capture binding

agent for the analyte measured at equilibrium and is a constant at a given temperature and other given conditions. Before thermodynamic equilibrium is reached, the above equation also approximately applies (provided that only an insignificant fraction of the analyte in the sample has become bound to the capture binding agent at the time of measurement of the fractional occupancy, irrespective of whether a higher, significant amount becomes bound subsequently, for example by the time equilibrium is reached), subject only to the alteration that in such a situation the constant K in the equation is the apparent affinity constant of the capture binding agent for the analyte at the time of measurement.

It has also been proposed by Roger Ekins in WO-89/01157 etc to carry out such a technique using the capture binding agent spotted onto a solid support in the form of one or more microspots, for example with diameters of 1 mm<sup>2</sup> or less, using sample volumes of the order of 1 ml or less.

However, with such a system a problem may arise to provide a label which can give a sufficiently strong but sensitive signal. Doubts have also been expressed regarding sensitivities attainable using microspot assay formats on the ground that the use of very small amounts of solid-phase capture binding agent must intrinsically necessitate long incubation times and yield low sensitivity assays.

#### Summary of the invention

We have now found that in such a system very good results can be obtained by using as the labelling system micron or preferably sub-micron sized microspheres carrying a marker, preferably a fluorescent label. By combining the use of such a label for the developing binding material alone or for both the developing binding material and the capture binding agent with very small amounts of capture binding agent located at a high surface density on a solid

- 5 -

support in the form of a microspot, non-competitive assay systems may be devised which are as rapid to perform as or even more rapid to perform than, and possess sensitivities comparable with or indeed greatly superior to, those of  
5 conventional sandwich systems relying upon comparatively large amounts of capture binding agent. This crucial finding, which contradicts currently accepted views on the design of high sensitivity assays and is totally unexpected, potentially forms the basis of development of a variety of  
10 superior miniaturized diagnostic devices possessing exceedingly high sensitivity whilst requiring only relatively short incubation and measurement times.

Of course, the microspheres can also be used for labelling purposes in a competitive assay system using  
15 similarly very small amounts of capture binding agent, but in such systems the limit on sensitivity may not in practice be the specific activity of the label, and corresponding or substantial increases in sensitivity due to the use of the microspheres would therefore not necessarily be achieved or  
20 even expected, although increases in rapidity can be expected.

According to the present invention there is provided a binding assay process in which the concentration of an analyte in a liquid sample is determined by comparison with  
25 a dose-response curve computed from standard samples, using a capture binding agent having binding sites specific for the analyte and a developing binding material capable of binding with the bound analyte or with the binding sites on the capture binding agent occupied by the bound analyte or  
30 with the binding sites remaining unoccupied on the capture binding agent, the capture binding agent being used in an amount such that only an insignificant fraction of the analyte in the sample becomes bound to the capture binding agent, and a label being used in the assay in relation to  
35 the developing binding material whereby the strength of the signal associated with the label is representative of the

- 6 -

fractional occupancy of the binding sites on the capture binding agent by the analyte, in which process there is used as the label microspheres having a size of less than 5  $\mu\text{m}$  and carrying a marker, preferably a fluorescent label.

5 In other embodiments (described below) the present invention provides a kit for use in a binding assay process, also a binding assay process for the detection or determination of an analyte comprising a single-stranded DNA sequence in a liquid sample.

#### 10 Detailed disclosure

Fluorescent microspheres of micron and submicron size have been known since about 1982 and are commercially available from many sources, e.g. from Seradyn Inc. or under the trade mark FluoSpheres from Molecular Probes Inc..

15 Suitable microspheres have a diameter of generally less than 5  $\mu\text{m}$  and preferably not more than 1  $\mu\text{m}$ , more preferably of the order of 0.01 to 0.5 $\mu\text{m}$ , and it is preferred to use spheres all essentially of the same standard size. The microspheres may be made of any suitable or convenient inert

20 material such as a polymer latex, for example a polystyrene latex, which is desirably provided on its surface with either negatively charged groups such as sulphate, carboxyl or carboxylate-modified groups or positively charged groups such as amidine groups. The presence of such charged groups

25 on the surface of the spheres allows a wide variety of proteins, such as IgG, avidin/streptavidin and BSA, to be adsorbed passively on or coupled covalently to the surfaces of the spheres at various surface densities as desired.

Although the microspheres may carry markers of various

30 types, for example radioactive, chemiluminescent or enzyme labels, they preferably carry fluorescent labels. The fluorescent and radioactive labels are preferably contained within the microspheres, where they are shielded from outside influences, but they may (and the enzyme and



- 7 -

chemiluminescent labels will in general) be present on the surface of the spheres. Each microsphere desirably contains large numbers of fluorescent dye molecules as labels, for example up to 10 million in 1  $\mu\text{m}$  diameter spheres with 5 smaller numbers in smaller spheres (e.g. 100 or 1,000 to 100,000 or 1 million) down to about 10 in very small spheres. The fluorescent dye molecules may be selected to provide fluorescence of the appropriate colour range (excitation and emission wavelength) compatible with 10 standard filter sets, for example yellow/green, orange or red, or customised filter sets may be used. Fluorescent dyes include coumarin, fluorescein, rhodamine and Texas Red. The fluorescent dye molecules may be ones having a prolonged fluorescent period such that the strength of the 15 signal emitted by them can be determined by the known time-resolved fluorescence technique after background interference has decayed, for example lanthanide chelates and cryptates. Dyes which fluoresce only in non-aqueous media can be used. Preferred fluorescent dyes for use in 20 the microspheres are oil-soluble dyes in order to facilitate their incorporation into the interior of the microspheres. Yellow/green, orange and red FluoSpheres, which are excited very efficiently at the 488, 568 and 647 nm krypton/argon mixed gas laser lines, respectively, are presently 25 preferred.

In use as the label for the developing binding material, or for the capture binding agent and the developing binding material, in the assay systems of the invention the microspheres may have the developing binding 30 material, or avidin which can be used as a "universal marker" reagent and bind all biotinylated binding material, or the capture binding agent as the case may be, physically adsorbed onto the surface of the spheres. More conveniently, however, appropriately surface-modified 35 microspheres are selected and the developing binding material (eg. antibody) or capture binding agent (eg. antibody) is covalently bonded to them either directly or

- 8 -

through a linking grouping, such as is provided by carbodiimide activation. Thus, for example, to link the microspheres and binding material the binding material may be adsorbed onto hydrophobic sulphate-modified microspheres  
5 or covalently coupled to aldehyde-modified or carboxylate-modified hydrophilic microspheres, the latter via a water-soluble carbodiimide. When both the capture binding agent and the developing binding material are labelled with fluorescent microspheres, different dyes will of course be  
10 used in the two sets of microspheres, and the signal strength ratio can then be determined and employed for comparison as in WO 88/01058.

It will be apparent therefore that the microspheres containing many molecules of a fluorescent dye provide an  
15 amplification system (as do microspheres containing or carrying several molecules of a label of other types, e.g. a radioactive or chemiluminescent label) in the sense that one molecule or unit of the developing binding material gives rise to a signal which is due to a large number of  
20 fluorescent dye molecules or a significant number of other label molecules. Such an amplification system is thus able greatly to increase the sensitivity of these assay procedures in which the controlling factor in assay sensitivity is signal magnitude, for example when only a  
25 very small amount of capture binding agent is used and hence the amount of developing binding material is also very small.

The microspheres are primarily used in conjunction with an assay system in which the immobilised material, usually  
30 the capture binding agent (capture antibody), is deposited on a solid support in the form of one or more microspots having an area of  $1 \text{ mm}^2$  down to  $100 \text{ } \mu\text{m}^2$  or less, for example a diameter of 0.01-1 mm, although for very small microspots it may be necessary to use very small microspheres or fewer  
35 larger microspheres. The surface density of the capture

- 9 -

binding agent on the microspot is desirably in the range 1,000 to 100,000 molecules/ $\mu\text{m}^2$ , preferably 10,000 to 50,000 molecules/ $\mu\text{m}^2$  in the case of antibodies. For other binding agents the surface density may be within this range or above 5 or below it but should preferably be as high as possible without sterically hindering binding of the analyte molecules. These microspots are used in conjunction with sample sizes of generally 1 ml or less, for example down to 50 or 100  $\mu\text{l}$  or even less depending on the size of the 10 microspot, the aim being to cover the microspot.

The microspot technique can be used to determine different analytes in the same or different liquid samples in a single operation by immobilising different capture binding agents on different microspots, for example 10 or 15 more, e.g. up to 50 or more, on the same solid support and using different or identical developing binding materials labelled with the microspheres for the different binding assays. The labels (e.g. fluorescent dyes) associated with 20 different binding assays and/or the techniques used to measure the signal strengths will be chosen to enable the results from the different assays to be differentiated. Techniques for this are known, for example from WO-88/01058.

To optimise the results achievable with the present invention a number of different features should be 25 optimised, including the following:-

- i) the fractional occupancy of the capture binding agent by the analyte,
- ii) the size of the affinity constant of the capture binding agent for the analyte at the time when measurement occurs and, if the measurement is to 30 be performed before equilibrium has been reached, the rate at which equilibrium is reached,
- iii) the surface density of the capture binding agent on its support,
- iv) the size of the microspots, 35

- 10 -

- v) the nature of the support,
- vi) the instrument used to measure the signal,
- vii) the treatment of the microspheres, for example to block unreacted sites, and
- 5 viii) the nature of the buffer solutions used.

For feature i) it should be noted that the use of too much capture binding agent is to be avoided for optimal sensitivity. It is theoretically demonstrable that the highest signal/noise ratio ( $R$ ) is obtained (assuming the measuring instrument itself generates zero noise) when the amount of capture binding agent falls below  $0.01/K$  and approaches zero,  $K$  being the affinity constant between the capture binding agent and the analyte at the time of measurement. Let us define this signal/noise ratio as  $R_0$ .  
10 (Note that an amount of capture binding agent of  $0.01/K$  binds  $< 1\%$  of analyte molecules present in the solution to which the capture binding agent is exposed.) If the area on which the capture binding agent is deposited is increased (the surface density of binding agent remaining constant)  
15 the amount of binding agent will concomitantly increase. The percentage of total analyte bound will also increase (albeit to a lesser proportional extent) but the signal/noise ratio will decrease. For example, if the area is increased 100-fold so that the amount of binding agent  
20 equals  $1/K$ , the amount of analyte bound will rise to  $\leq 50\%$ , and the signal/ noise ratio will fall to the order of  $R_0/2$ .

The relationship between the ratio  $R$  and capture binding agent concentration (ie area coated with binding agent) is shown in Figure 1 of the accompanying drawings.  
30 This Figure is a graph of the signal/noise ratio (the continuous line where the y-axis is % of the value when the area coated with binding agent, and hence the binding agent concentration, approaches zero) and the amount of bound analyte (the dashed line, where the y-axis is % of total  
35 analyte present in the medium, assuming the total amount of analyte is very low, ie  $< 0.0001/K$ ) as functions of the total

- 11 -

amount of capture binding agent (in units of  $1/K$ , the x-axis) on the coated area. Clearly, as the area coated with capture binding agent (and hence its concentration) increases, the percentage of total analyte bound increases, 5 but the signal/noise ratio falls. This effect is shown pictorially in Figure 2 of the accompanying drawings, where  $d$  is the diameter in mm of the area coated with capture binding agent,  $[Ab]$  is the concentration of binding agent assuming a surface density of  $0.1/K$  per  $\text{mm}^2$ , and  $s/n$  is the 10 signal/noise ratio expressed as a percentage of the value observed as the surface area approaches zero. This Figure likewise endeavours to show that, as the coated area increases, the amount of analyte bound also increases but the signal/noise ratio and hence the sensitivity fall.

15 However, although the signal/noise ratio  $R$  is highest when the binding agent concentration is less than  $0.01/K$ , it is clear that the ratio may still be acceptably high when the amount of capture binding agent used equals or even exceeds  $1/K$ . The upper limit to the amount of binding agent 20 coated on the microspot area is preferably  $10/K$ . This implies a ten-fold lower sensitivity than is achievable using a 1000-fold lower amount of binding agent and it should be emphasized that, although the invention is capable of yielding very high sensitivity, it is also applicable 25 where lower sensitivity than the maximum attainable is acceptable.

For factor ii) it should be noted that, although at first sight it might appear to be better to use a capture binding agent with a low equilibrium value of  $K$ , it is in 30 fact generally found that for high-sensitivity assays it is better to use binding agents having higher values of  $K$  at equilibrium, e.g.  $10^{11}$  -  $10^{12}$  or more litres/mole, and (if necessary or desired) to make the measurement before equilibrium has been reached so that at the moment of 35 measurement only an insignificant fraction of the analyte

- 12 -

has become bound and the effective value of K at the moment of measurement may be considerably less, e.g.  $10^8$ - $10^{11}$ , even though a substantial fraction of the analyte might become bound if measurement were to be delayed until equilibrium had been reached. Higher effective values of K may be more appropriate where the analyte concentration is low (e.g.  $10^6$  molecules/ml) and lower effective values of K may be more appropriate where the analyte concentration is high (e.g.  $10^{14}$  molecules/ml). Desirably, the effective value of K is of the order of the reciprocal of the analyte concentration to be measured in the sample. It is preferred to use a capture binding agent such that, in the amounts used, equilibrium is reached within 12 hours or somewhat less but to make the measurement within about 2 hours or less, well before equilibrium is reached. This early pre-equilibrium measurement is particularly important where the capture binding agent has a very high affinity constant for the analyte, as is the case with DNA probes.

For factor iii) it should be noted that too low a surface density decreases the signal/noise ratio because the area occupied by the capture binding agent and scanned to determine the ratio increases. On the other hand too high a surface density can cause steric hindrance between adjacent capture binding agent molecules so that not all the molecules are available for binding the analyte. Preliminary experiments to see if steric hindrance is a problem can be carried out by making spots of varying binding agent surface density, labelling them with a label such as  $^{125}\text{I}$  and measuring how the signal varies with binding agent surface density, the optimum being the highest signal. In the past, conventional practice has been to use coatings of the order of 10  $\mu\text{g}$  of capture binding agent (antibody) per ml but for the present invention figures of 100-200  $\mu\text{g}$  of capture binding agent (antibody) per ml may be more appropriate. The use of higher surface density also has the advantage that less of the surface is available for non-specific binding, which would otherwise increase the

- 13 -

noise and reduce the signal/noise ratio.

For factor v) it should be noted that the support used will itself contribute to the noise level. If the level of background noise is a problem it may be preferable to use a  
5 black support rather than a white one, although this may decrease the signal level and some black supports have higher noise levels than others.

For factor vi) it is preferred to maximise the signal/noise ratio. Accordingly, the area from which the  
10 signal is measured is desirably small, preferably limited to the area of the microspot or a portion of it. Measuring the signal from a wider area beyond the microspot increases the noise level without increasing the signal level and thus decreases the signal/noise ratio. Hence it may be desirable  
15 to concentrate the illumination and to make measurements by means of a confocal microscope or other instrument achieving very precise illumination.

For factor vii) it is desirable that, after adsorption or covalent bonding of the developing binding material or  
20 capture binding agent to the microspheres has been carried out, the unreacted sites on the microspheres are blocked to avoid their non-specific binding to other biological molecules or the solid support for the capture binding agent. Blocking may be carried out with any non-interfering  
25 protein material. An albumin, particularly bovine serum albumin, is preferred. It has been found desirable to block not only with bovine serum albumin (BSA) or equivalent but also with a detergent such as TWEEN-20 or other non-ionic detergent. It is believed that there are some binding  
30 sites on the microspheres which are not blocked by BSA or other protein material alone. Microspheres blocked with BSA alone appear still to have binding sites which are capable of binding to the solid support, such as the plastic walls of the microtitre wells in which the assay is  
35 performed, or to other biological or non-biological

- 14 -

molecules such as are present in other components of the system (eg the liquid sample), as well as being capable of non-specific binding to the capture binding agent. Use of a detergent as additional blocking agent decreases the number of such binding sites or eliminates them altogether.

The detergent also helps to remove loosely bound binding agent or material or other proteins which might desorb into storage buffer and/or assay buffer and interfere with assays. Non-interfering reactants can be used to block activated groups on the surface of the microspheres, for example inert amines such as ethanolamine, glycine or lysine to block activated carboxyl groups, but any particular compounds should be checked for assay compatibility.

For factor viii) it should be noted that the choice of ingredients for the assay buffer and the wash buffer can influence the sensitivity of the results. With TSH, for example, TRIS gives a better buffer than phosphate. It may also be desirable to include a detergent in the buffer such as TWEEN 40 to reduce non-specific binding.

In other respects the immunoassay may be carried out in a known manner, for example as described in Roger Ekins' earlier patent applications as mentioned above, and incorporated herein by reference, or in the other literature. When carrying out immunoassays it is preferred, although not essential, for both the capture binding agent and the developing binding material to be antibodies. Monoclonal or polyclonal antibodies may be used and the procedure may be used to assay analytes such as hormones, nucleic acid, proteins, vitamins, drugs, viruses, bacteria, pesticides, tumour markers or other components of biological samples such as body fluids, the capture binding agent and developing binding material being appropriately chosen so as to bind to the analyte in question. The analyte in a binding assay can be a nucleotide sequence, eg a DNA oligonucleotide sequence in which case the capture binding agent and the developing binding material may both be other



- 15 -

nucleotide sequences, which will differ from one another. The analyte may contain only one epitope for the capture binding agent or the epitope may be replicated on the analyte molecule. The polyclonal developing binding material (antibody) may react with a variety of epitopes on the analyte or the analyte capture binding agent complex, or a mixture of two or more monoclonal developing binding materials (antibodies) reacting with different epitopes may be used.

10 When used for nucleic acid (DNA) assays the DNA probe, a single-stranded nucleotide sequence, eg an oligonucleotide sequence of conventional or standard type, is attached as capture binding agent to a solid support and this recognises a corresponding single-standard DNA sequence constituting  
15 the analyte in a liquid sample and such sequences become bound so as to form a twin-stranded sequence. DNA probes consisting of oligonucleotide sequences are available commercially from a number of companies, e.g. Clontech Laboratories Inc., or they can be synthesised to order  
20 and/or modified (e.g. with biotin or digoxigenin) by commercial companies, e.g. British Biotechnology Products Ltd. The developing binding material may be either a labelled antibody which recognises the twin-stranded sequence as opposed to single-stranded sequences (see Figure  
25 3 of the accompanying drawings) or another DNA sequence which recognises another part of the DNA sequence constituting the analyte and is labelled (see Figure 4 of the accompanying drawings), both these binding materials producing non-competitive assays. For competitive assays it  
30 is possible to use a labelled developing binding material recognising unoccupied sites of the capture binding agent, ie residual DNA probe not bound to analyte (see Figure 5 of the accompanying drawings). In each case the label is provided in accordance with the invention by the  
35 microspheres carrying a marker, preferably molecules of a fluorescent dye contained within the microspheres. In each of Figures 3-5 A represents a microspot, B the capture

- 16 -

binding agent and M the microspheres. In Figure 3 AbDSD is an antibody to double stranded DNA, and in Figure 4 AbD is anti-digoxigenin antibody and D is digoxigenin. Hybridisation techniques using these methodologies are already known, see for example:- Guesdon J-L (1992), "Immunoenzymatic Techniques Applied to the Specific Detection of Nucleic Acids", Journal of Immunological Methods 150, 33-49; Mantero G, Zonaro A, Albertini A, Bertolo P & Primi D. (1991), "DNA Enzyme Immunoassay: General Method for Detecting Products of Polymerase Chain Reaction", Clinical Chemistry 37/3, 422-429; Keller G.H., Huang D-P, Shih W-K & Manak M.M. (1990), "Detection of Hepatitis B Virus DNA in Serum by Polymerase Chain Reaction Amplification and Microtiter Sandwich Hybridization", Journal of Clinical Microbiology 28/6, 1411-1416; Nickerson D.A., Kaiser R., Lappin S, Stewart J, Hood L & Landegren U (1990), "Automated DNA Diagnostics Using an ELISA-based Oligonucleotide Ligation Assay", Proceedings of the National Academy of Sciences 87, 8923-8927; Wolf S.F., Haines L., Fisch J., Kremsky J.N., Dougherty J.P. & Jacobs K. (1987), "Rapid Hybridization Kinetics of DNA Attached to Submicron Latex Particles", Nucleic Acids Research 15/7, 2911-2926.

DNA assays according to the present invention therefore provide an alternative to the well-known polymerase chain reaction (PCR) for assaying DNA sequences. The PCR method is subject to certain disadvantages, including errors introduced by repeated cycles of amplification (doubling) on an initial very low concentration of DNA sequence. The present invention provides an alternative enhancement procedure in which an initial very low concentration of the DNA sequence to be detected or determined gives rise to an amplified signal in a single step because of the large number of fluorescent dye molecules contained within the microsphere to which a molecule of the developing binding material (antibody or other DNA sequence) is attached as by adsorption or direct

- 17 -

or indirect chemical bonding.

According to a further embodiment of the invention there is provided a binding assay process for the detection of an analyte comprising single-stranded DNA sequence in a liquid sample, the process comprising contacting the sample in a non-competitive or competitive procedure with an immobilised capture binding agent which is a single-stranded oligonucleotide DNA probe capable of recognising analyte in the liquid sample and binding therewith, and with a labelled developing binding material which either is an antibody capable of recognising only twin-stranded DNA sequences formed from the probe and the analyte and of binding therewith or is an oligonucleotide DNA sequence capable of recognising and binding with either another part of the analyte or the residual probe, the developing binding material being labelled by means of microspheres having a size of less than 5  $\mu\text{m}$  and carrying a marker, and, after the removal of unattached developing binding material, detecting the presence of the analyte by the existence or strength of a signal from the marker attached to developing binding material which has become bonded directly or indirectly to the immobilised capture binding agent.

Preferably, the marker is a fluorescent label, eg in the form of a large number (100 or more) of fluorescent dye molecules contained within microspheres having a size of 0.01 to 1  $\mu\text{m}$ , eg 0.05 - 0.5  $\mu\text{m}$ . It is preferred to use this technique in conjunction with the microspot technique already referred to, with the capture binding agent being immobilised as one or more microspots on a solid support at the surface densities and microspot sizes already mentioned and optionally different capture binding agents being immobilised on different microspots on the same support to enable a plurality of different DNA sequences to be detected or determined in a single operation using appropriately differentiated developing binding materials and signal detection or signal strength measurement techniques.

- 18 -

The procedures for forming a single-stranded DNA probe and immobilising it on a solid support are well known and described in the literature, for example the Guesdon and other references mentioned above, and standard techniques 5 can be used for this and for the formation, e.g. by boiling, of the liquid sample containing the analyte (single-stranded DNA sequence which may or may not be present) to be detected. Coupling of the developing binding material to the microspheres may be carried out by a method known for 10 immobilising to marker-free solid support, for example as described in the Wolf et al reference mentioned above, and the usual precautions to avoid contamination etc and other disturbing influences should be taken.

In a further embodiment the present invention provides 15 a kit for use in a binding assay process in which the concentration of an analyte in a liquid sample is determined using a capture binding agent having binding sites specific for the analyte and a developing binding material capable of binding with the bound analyte or with the binding sites on 20 the capture binding agent occupied by the bound analyte or with the binding sites remaining unoccupied on the capture binding agent, a label being used in relation to the developing binding material whereby the strength of the signal associated with the label is representative of the 25 fractional occupancy of the binding sites on the capture binding agent by the analyte, the kit comprising (a) a solid support having the capture binding agent immobilised thereon, (b) a developing reagent comprising the developing binding material adsorbed or directly or indirectly 30 chemically bonded to the surface of microspheres carrying a marker and (c) standards having known amounts or concentrations of the analyte to be determined.

Preferably, the developing reagent comprises a buffered solution containing the developing binding material 35 attached to the microspheres, but it is also possible to provide the reagent in freeze-dried form. Similarly, the

- 19 -

standards may also be provided as buffered solutions containing the analyte at known concentrations or in freeze dried form with instructions for appropriate reconstitution in solution form. The standards may be made up in hormone-free serum. There may be three or more standards, e.g. up to 12, of varying known analyte concentrations spanning the expected values in the unknown samples.

Preferably, the developing reagent contains the developing binding material adsorbed onto or covalently bonded to microspheres having a size of less than 5  $\mu\text{m}$  and containing molecules of a fluorescent dye, and it is preferred that the solid support has the capture binding agent immobilised thereon in the form of one or more microspots of size less than 1  $\text{mm}^2$  and surface density at least 1000 molecules/  $\mu\text{m}^2$ . Different capture binding agents may be immobilised on different microspots on the same solid support and a plurality of different developing reagents and different sets of standards may be provided so that a variety of different assays for different analytes may be performed using the same solid support in a single operation, simultaneously or sequentially.

The invention is further described in the following Examples, which illustrate the preparation of the labelled developing binding material (Examples 1-4) and processes and kits according to the invention (Examples 5-12).

In the Examples concentration percentages are by weight.

#### Example 1

#### 30 Adsorption of Antibody or Avidin on Hydrophobic Sulfate-Microspheres

1) 0.5 ml of 2% solids suspension in pure water of surfactant-free sulphate-activated microspheres of polymer

- 20 -

latex materials containing fluorescent dye molecules within the microspheres (FluoSpheres from Molecular Probes Inc - FluoSpheres is a Registered Trade Mark) having a diameter 0.08 or 0.12 $\mu$ m was added dropwise to 2 mg of developing 5 binding material (antibody or avidin) dissolved in 1 ml of 0.1 M phosphate buffer at pH 7.4. The suspension was shaken overnight at 4°C.

2) The suspension was centrifuged at 20,000 rpm for 30 min at 10°C (the time and speed of the centrifugation will vary 10 with the size of the latex microspheres) to separate antibody-conjugated latex microspheres from unreacted antibody. The supernatant antibody or avidin solution was recovered for protein estimation.

3) The centrifuged pellet was dispersed in 1.0 ml of 0.1 M 15 phosphate buffer by sonication. After dispersion, the unoccupied hydrophobic sites on the microspheres were blocked by the addition of 1 ml of 2% (1% final) bovine serum albumin (BSA) and shaken for 2 hours at room temperature. The spheres were further blocked by the 20 addition of 200 $\mu$ l of 5% Tween-20 (~0.5% final) and shaken for 1 hour at room temperature. The detergent incubation step also served to get rid of loosely bound antibody/avidin which might desorb into storage and/or assay buffer and would subsequently interfere with assays.

25 4) The preparation was centrifuged as above and the microspheres resuspended in 2 ml of 0.1 M phosphate buffer.

5) Step 4 was repeated twice. After the final 30 centrifugation, the microspheres were dispersed in 2 ml of phosphate buffer containing 0.2% BSA and 0.01% sodium azide and stored at 4°C.

- 21 -

Example 2Covalent Coupling of Antibody or Avidin to Carboxylate-Modified Latex Microspheres by a one-step method

- 1) 0.5 ml of a 2% solids suspension in pure material of  
5 carboxylate-modified polymer latex microspheres containing  
fluorescent dye molecules (FluoSpheres from Molecular Probes  
Inc) and having a diameter of 0.09  $\mu\text{m}$  was added dropwise to  
0.5 ml of 0.015 M, pH 5 acetate buffer containing 2 mg of  
antibody or avidin as developing binding material. The  
10 suspension was incubated at room temperature for 15 min.
  
- 2) 4 mg of EDAC [1-ethyl-3-(3-dimethylaminopropyl)-  
carbodiimide] (Sigma Chemical Company) was added to the  
mixture and vortexed. The pH was adjusted to  $6.5 \pm 0.2$  with  
dilute NaOH (agglomeration of the latex microspheres may be  
15 observed at this stage, but they can be redispersed by  
gentle sonication) and the reaction mixture was mixed gently  
overnight at 4°C.
  
- 3) The reaction mixture was centrifuged at 20,000 rpm for  
30 min at 10°C. The supernatant was recovered for protein  
20 estimation.
  
- 4) The centrifuged pellet was dispersed in 1.0 ml of 0.1M  
phosphate buffer by sonication. After dispersion, the  
unoccupied sites on the microspheres were blocked by the  
addition of 1 ml of 2% (1% final) bovine serum albumin (BSA)  
25 and shaken for 2 hours at room temperature. The spheres  
were further blocked by the addition of 200 $\mu\text{l}$  of 5% Tween-20  
(~0.5% final) and shaken for a further 1 hour at room  
temperature.
  
- 5) The preparation was centrifuged as above and the  
30 microspheres resuspended in 2 ml of 0.1M phosphate buffer.
  
- 6) Step 5 was repeated twice and, after the final

- 22 -

centrifugation, the antibody- or avidin- conjugated microspheres were dispersed in 2 ml of phosphate buffer containing 0.2% BSA and 0.01% of sodium azide and kept at 4°C.

5

Example 3Covalent Coupling of an Antibody or Avidin to Carboxylate-Modified Latex Microspheres by a two-step method

- 1) 0.5ml of the suspension of carboxylate-modified latex microspheres used in Example 2 was added to a 10 ml centrifuge tube and centrifuged at 20,000 rpm for 30 min at 10°C.
- 2) The centrifuged pellet was resuspended in 0.5ml of 0.02 M phosphate buffer, pH 4.5, and centrifuged as above.
- 3) Step 2 was repeated.
- 15 4) 0.5 ml of a 2% solution of EDAC was added dropwise to the dispersed microspheres (agglomeration of the latex microspheres may be observed at this stage, but they can be redispersed by gentle sonication), and the reaction mixture was mixed gently at room temperature for 3 hours and 20 centrifuged as above.
- 5) The centrifuged pellet was resuspended in 1 ml of 0.2 M borate buffer, pH 8.5, and centrifuged as above.
- 6) Step 5 was repeated twice.
- 7) The centrifuged pellet was resuspended in 0.5 ml of 25 borate buffer, added dropwise to 2 mg of antibody or avidin dissolved in 0.5 ml of the same buffer and mixed gently overnight at room temperature.
- 8) The suspension was centrifuged as above and the



- 23 -

supernatant was kept for protein estimation.

9) The centrifuged pellet was resuspended in 1 ml of 0.1M ethanolamine in borate buffer, mixed gently for 30 min at room temperature and centrifuged as above.

5 10) The centrifuged pellet was resuspended in 1 ml of 1% BSA, mixed gently for 1 hour and centrifuged as above.

11) The centrifuged pellet was resuspended in 1 ml of 0.5% Tween-20, mixed gently for 1 hour and centrifuged as above.

12) The centrifuged pellet was resuspended in 1 ml of 0.02 M phosphate buffer, pH 7.4, and centrifuged as above.

13) The centrifuged pellet was resuspended in 1 ml of phosphate buffer containing 0.2% BSA and 0.01% of sodium azide and kept at 4°C.

#### Example 4a

#### 15 Coupling of a Mixture of Antibody and Avidin to Microspheres by Adsorption or Covalent Linkage

The methodologies for the coupling of a mixture of antibody and avidin to microspheres by adsorption or covalent linkage were essentially the same as those described in Examples 1 to 3 above for the coupling of antibody or avidin to microspheres except that the antibody solution used for the reaction also contained a small amount of avidin.

#### Example 4b

#### 25 Labelling of a Monoclonal Anti-TSH Antibody with Texas Red

1) 1 mg of monoclonal anti-TSH antibody was dissolved in 1 ml of carbonate buffer pH 9.

- 24 -

- 2) 1 mg of Texas Red (Molecular Probes Inc.) was dissolved in 250 $\mu$ l of N,N-Dimethylformamide (Sigma Chemical Company), yielding a concentration of 4 $\mu$ g/ $\mu$ l.
- 3) 10 $\mu$ l of the 4 $\mu$ g/ $\mu$ l Texas Red was added to the antibody solution, vortexed and left on ice for two hours (dye to protein ratio (w/w) = 0.04).
- 4) The Texas Red-conjugated antibody was separated from unreacted and hydrolysed dye on a PD10 Sephadex column (Pharmacia) by elution with 0.1M phosphate buffer, pH 7.4.
- 5) Sodium azide was added to the labelled antibody (0.1%) as preservative and the preparation was stored at 4°C.

#### Example 4c

##### Labelling of Antibody or BSA with Biotin

- 1) 2 mg of antibody or BSA was dissolved in 1 ml of pH 8.5 bicarbonate buffer.
- 2) 2.2 mg of N-Hydroxysuccinimidyl 6-(Biotinamido) Hexanoate (Vector Laboratories) was dissolved in 55 $\mu$ l of N,N-Dimethylformamide, yielding a concentration of 40 $\mu$ g/ $\mu$ l.
- 3) 10 $\mu$ l of the 40 $\mu$ g/ $\mu$ l biotin was added to the antibody or BSA solution and shaken for 2 hours at room temperature (biotin to protein ratio (w/w) = 0.2).
- 4) The reaction was terminated by the addition of 10 mg of glycine.
- 5) The biotin-conjugated IgG or BSA was separated from unreacted biotin on a PD10 Sephadex column (Pharmacia) by elution with 0.1M phosphate buffer, pH 7.4.
- 6) Sodium azide was added to the conjugated preparation

- 25 -

(0.1%) which was stored at 4°C.

#### Example 5

### An Ultra-sensitive Sandwich Two-step Back-titration TSH Microspot Immunoassay employing Developing Antibody 5 Conjugated to Fluorescent Microspheres

#### First Step

1) White polystyrene microtitre wells (Microlite 1 from Dynatech Laboratories) were spotted with 1 $\mu$ l or less of a 200 $\mu$ g/ml monoclonal anti-TSH capture antibody in 0.1M phosphate buffer at pH 7.4. The antibody droplets were aspirated immediately and the wells blocked with 1% (w/v) BSA and washed extensively with the same buffer. The antibody microspots were kept in buffer until use.

2) After rinsing with 0.05M/l Tris-HCl buffer at pH 7.75 (wash buffer), 200 $\mu$ l of either standard in assay buffer or the sample was added to each well and shaken for from 30 min to several hours at room temperature (or overnight at 4°C if maximal assay sensitivity is desired).

3) The wells were washed four times with wash buffer.

#### 20 Second step

1) An aliquot of 200 $\mu$ l of developing binding material antibody conjugated to fluorescent-dye containing microspheres of diameter 0.1  $\mu$ m (containing ~0.01 mg antibody-conjugated microspheres) in assay buffer was added to each well and shaken for 0.5 to 1 hour at room temperature.

2) The wells were washed seven times with the wash buffer which contained 0.05% Tween-20 (w/v), aspirated until completely dry and scanned with an MRC-600 Laser Scanning

- 26 -

Confocal Microscope (Bio-Rad Microscience). The signal emitted from each antibody microspot was quantified and the results were compared with the standard dose-response curve to determine TSH concentrations in unknown samples.

- 5 The standards used for production of the dose-response curve contained 0.01, 0.03, 0.1, 0.3, 1, 3, 10 and 30  $\mu$ U TSH/ml in the assay buffer.

The assay buffer composition was:

	Tris-(hydroxymethyl)-aminomethane	50 mM/l
10	Sodium chloride	9.0 g/l
	Bovine serum albumin	5.0 g/l
	Bovine globulin	0.5 g/l
	Tween 40	0.1 g/l
	Sodium azide	0.5 g/l
15	HCl	to a pH of 7.75 at 25°C

#### Example 6

An assay for thyroid stimulating hormone (TSH) was carried out using two monoclonal antibodies directed at different epitopes on the TSH molecule as capture and  
 20 developing antibodies, and TSH standard samples supplied by the National Institute for Biological Standards and Control. The capture antibody was deposited as microspots approximately 0.5 mm in diameter on Dynatech Microlite microtitre wells by passive adsorption, giving a surface  
 25 density of about 40,000 IgG molecules/ $\mu$ m<sup>2</sup>. The developing antibody was covalently coupled to carboxylate-modified polystyrene latex FluoSpheres 0.08  $\mu$ m in diameter containing yellow/green fluorescent dye. The TSH samples were applied to the microtitre wells in amounts of about 200  $\mu$ l.

- 30 Following overnight incubation, the results obtained were as plotted on Figure 6 of the accompanying drawings, which is a graph of fluorescence intensity (y-axis) in

- 27 -

arbitrary units against TSH concentration (x-axis) in mU/litre. The sensitivity of the assay (based on measurements of the standard deviation of the zero dose estimate) was 0.002 mU/litre. The same standards and assay buffer as those used in Example 5 were employed.

#### Example 7

Example 6 was repeated except that the total incubation time was reduced to 1 hour (0.5 hour incubation of sample with capture antibody, followed by 0.5 hour incubation with developing antibody) and the size of the microspheres was increased to 0.12  $\mu\text{m}$  diameter. The sensitivity of the assay was thereby increased ten-fold to 0.0002 mU/litre, based on measurements of the standard deviation of the zero dose estimate. The results are plotted in Figure 7 of the accompany drawings, which is a graph on the same axes as Figure 6.

#### Example 8

A Single-step Ultra-sensitive Sandwich TSH Microspot Immunoassay Using Developing Antibody Conjugated to Fluorescent Microspheres

1) White polystyrene microtitre wells (Microlite 1 from Dynatech Laboratories) were spotted with 1 $\mu\text{l}$  or less of a 200 $\mu\text{g}/\text{ml}$  monoclonal anti-TSH capture antibody in 0.1 M phosphate buffer at pH 7.4. The antibody droplets were aspirated immediately and the wells blocked with 1% (w/v) BSA and washed extensively with the same buffer. The antibody microspots were kept in buffer until use.

2) The wells were rinsed with the assay buffer used in Example 5, then 100 $\mu\text{l}$  of standard in assay buffer/sample and 100 $\mu\text{l}$  of developing antibody-conjugated microspheres were added to each well and shaken at room temperature for 30 minutes, or longer if maximal assay sensitivity was desired.

- 28 -

3) The wells were washed seven times with wash buffer containing 0.05% Tween-20 (w/v), aspirated until completely dry and scanned with the confocal microscope as in Example 5 above, the results being compared with the standard dose-response curve obtained using the standards mentioned in Example 5 to determine the TSH concentration in unknown samples.

#### Example 9

#### Dual-labelled Ultra-sensitive Sandwich Single- or Two-step Back-titration TSH Microspot Immunoassay Using Developing Antibody Conjugated to Fluorescent Microspheres

The protocols for the dual-labelled single or two-step assays are essentially the same as those for the single labelled assays described above except the unlabelled capture antibody is either labelled with Texas Red (Molecular Probes Inc.) and deposited directly on the white Dynatech Microlite microtitre wells; or it can be coupled together with avidin to latex microspheres (Molecular Probes Inc) containing red fluorescent dye and the conjugated microspheres are then allowed to bind to a biotin-labelled BSA microspot deposited previously on the microtitre wells.

#### Example 10

A dual-label assay was carried out. The developing antibody was conjugated to yellow/green polystyrene latex microspheres of 0.12  $\mu\text{m}$  diameter as described in Examples 1, 2 and 3. The capture antibody was deposited indirectly on Dynatech Microlite microtitre wells at a surface density of about 40,000 IgG molecules/ $\mu\text{m}^2$  via biotin/avidin. The antibody was first conjugated together with avidin to polystyrene latex microspheres of 0.1  $\mu\text{m}$  diameter containing red fluorescent dye, the conjugated spheres then being allowed to bind to biotinylated BSA microspots previously coated on the microtitre wells. The yellow/green and

- 29 -

orange/red dyes were scanned using the 488 and 568 nm lines of the krypton/argon mixed-gas laser. This could be done either simultaneously or consecutively. The concentration of antigen (TSH) in the test sample was obtained by  
5 observing the ratio of the fluorescent signals from the two dyes and correlating it with the signals using the standard samples.

The results obtained are shown in Figure 8 of the accompanying drawings, which is a graph of the ratio of the  
10 two fluorescent signals (y-axis) against TSH concentration (x-axis) in mU/litre. The sensitivity of the assay (based on measurements of the standard deviation of the zero dose estimate) was 0.0002 mU/litre.

#### Example 11

#### 15 Single-labelled or Dual-labelled Ultra-sensitive Sandwich Single- or Two-step Back-titration TSH Microspot Immunoassay Using Biotinylated Developing antibody and a Universal Reagent of Avidin conjugated Fluorescent Microspheres

In contrast to the assay systems described in Examples  
20 5 to 10, a universal marker reagent of avidin conjugated fluorescent microspheres was used in this Example to tag indirectly the bound developing antibody which had been labelled with biotin.

Although this assay system requires an additional step  
25 of the addition of avidin microspheres after the completion of the immunological reactions, the advantage of being able to use a "universal marker" outweighs this minor drawback. The "universal marker" system would be particularly useful in a microspot multianalyte system described by Roger Ekins  
30 in WO-89/01157 because of the considerable improvements in assay sensitivity that can be expected as a result of the reduction in non-specific binding from employing a single universal avidin-microsphere preparation rather than the

- 30 -

large number (equivalent to the number of simultaneous assays being performed) of developing antibody conjugated microsphere preparations that would otherwise be required.

Example 12

5 Microspot DNA Sequence Assay Methodologies

Non-competitive methodologies (qualitative and quantitative assays)

Example 12a

Microspot sandwich DNA sequence assay using a  
10 biotinylated solid-phased capture DNA probe and anti-double-stranded DNA antibody conjugated to microspheres containing fluorescent dye.

1) Microlite 1 microtitre wells were spotted with 1  $\mu$ l or less of 100  $\mu$ g/ $\mu$ l Avidin DX (Vector Laboratories) by  
15 adsorption for 1 hour at room temperature, blocked for 20 min with 200  $\mu$ l of 0.1 M Tris-HCl pH 7.5 containing 0.15 M NaCl, 0.05% Tween 20, 0.5% BSA and 100  $\mu$ g/ml salmon sperm DNA and washed with Tris-HCl containing 0.05% Tween 20.

2) 5 to 100 ng of the biotinylated capture DNA probe  
20 purchased from Clontech Laboratories in 100  $\mu$ l of Tris EDTA was added to the avidin DX coated wells, incubated with shaking for 2hr at room temperature and washed with Tris-HCl containing 0.05% Tween 20.

3) In a modification of the procedure described in the  
25 Manero et al reference (see above) samples were prepared by boiling 0.5ml aliquots of the unknown samples for 10 min, then cooled rapidly on ice, diluted with hybridization buffer containing : 1X SSC (150 mmol/l of NaCl and 15mmol of trisodium citrate per litre), 2X Denhardt's solution (0.4 g  
30 of BSA, 0.4 g of Ficoll and 0.4 g of polyvinylpyrrolidone per



- 31 -

litre), 10mmol/l Tris-HCl pH7.5, and 1mmol/l EDTA. For a quantitative assay, the prepared samples or, as the case may be, standards containing single-stranded target DNA in known amounts and in the same hybridisation buffer were added to the wells (positive and negative controls rather than the standards were added to the other wells for the qualitative tests), incubated with shaking at 50°C for 1 hour and washed with PBS containing 0.05% Tween 20.

4) 200  $\mu$ l of anti-double-stranded DNA antibody conjugated to fluorescent microspheres of diameter 0.1  $\mu$ m (FluoSpheres) by the method described in Example 3 and in PBS containing 0.5% BSA and 0.05% Tween 20 was added, incubated with shaking for 1 hour at room temperature, washed with PBS-Tween 20 and scanned with the confocal microscope as described in Example 5.

#### Example 12b

Microspot sandwich DNA sequence assay using a biotinylated solid-phased capture DNA probe, a complementary but non-overlapping developing DNA probe labelled with digoxigenin and anti-digoxigenin antibody conjugated to microspheres containing fluorescent dye.

- 1) The avidin-biotinylated capture DNA probe microspots were prepared as described in Example 12a.
- 2) The hybridisation step was carried out as described in Example 12a.
- 3) 5 to 10 ng of the complementary but non-overlapping developing DNA probe labelled with digoxigenin (as described in the Nickerson et al reference above) in 100  $\mu$ l of hybridization buffer was added, incubated with shaking at 50°C for 1 hour and washed with PBS-Tween 20.
- 4) 200  $\mu$ l of the anti-digoxigenin antibody-conjugated

- 32 -

fluorescent microspheres of about 0.1  $\mu\text{m}$  diameter (FluoSpheres) in PBS containing 0.5% BSA and 0.05% Tween 20 were added, incubated for 1 hour at room temperature with shaking, washed with PBS-Tween 20 and scanned with the 5 confocal microscope.

Example 12c - 12e

Microspot sandwich DNA sequence assay using an unlabelled solid-phased capture DNA probe and either anti-  
10 double-stranded DNA antibody conjugated to microspheres containing fluorescent dye or a complementary but non-overlapping biotinylated developing DNA developing probe and  
15 labelled with digoxigenin and antidigoxigenin antibody conjugated to microspheres containing fluorescent dye may be carried out in a similar manner with appropriate changes.

Competitive DNA sequence assay methodology (quantitative and qualitative)

20

Example 12f

Microspot DNA sequence assay using a biotinylated solid-phased capture DNA probe and a competitive material of target DNA sequence labelled with microspheres containing fluorescent dye.

25 1) The avidin-biotinylated capture DNA probe microspots were prepared as described in Example 12a.

2) Samples were prepared by boiling 0.5 ml aliquots of the unknown samples for 10 min, then cooled rapidly on ice, and diluted with hybridization buffer containing : 1X SSC  
30 (150 mmol/l of NaCl and 15 mmol of trisodium citrate per litre), 2X Denhardt's solution (0.4 g of BSA, 0.4 g of Ficoll and 0.4 g of polyvinylpyrrolidone per litre), 10 mmol/l

- 33 -

Tris-HCl pH 7.5, and 1 mmol/l EDTA. For a quantitative assay, the prepared sample plus the competitive material of target DNA sequences generated by polymerase chain reaction and labelled with fluorescent microspheres of diameter 5 0.1  $\mu\text{m}$  (FluoSpheres) prepared using a technique modified from that described in the Wolf et al reference mentioned above for the attachment of DNA to latex particles, or standards containing single-stranded target DNA plus the competitive material and in the same hybridization buffer 10 were added to the wells (positive and negative controls plus the competitive material instead of the standards plus the competitive material were added for the qualitative tests), incubated with shaking at 50°C for 1 hour, washed with Tris-HCl containing 0.05% Tween 20 and scanned as described in 15 Example 5.

As indicated above, these very high sensitivities for non-competitive immunoassays are unexpected in the light of the currently accepted views on assay design. Some increase in sensitivity would be expected in any assay format, once 20 the idea of using microspheres in accordance with the invention has been appreciated, because of the increased number of molecules of label attached to each molecule of developing binding material, this resulting in an effective increase in specific activity of the labelled developer 25 molecules. However, this effect alone might not be expected to result in assay designs departing so markedly from conventional concepts in this field and requiring in particular very small amounts of capture binding agent.

Two further possible explanations for these unexpected 30 findings can perhaps be advanced. The first is that by confining a very small number of capture binding agent molecules at high surface density to a very small area in the form of a microspot the signal/noise ratios obtained in any finite incubation time may be improved as compared with 35 those obtained in conventional designs in which very large amounts of capture antibody are distributed over large

- 34 -

surface areas. The second is that when analyte molecules are located between two solid surfaces on which the capture binding agent and developing binding material molecules are respectively located (viz the microspheres and the 5 microtitre wells in which the assay is performed) binding sites on the analyte molecules may become bound to multiple developing binding material molecules if the analyte contains the same epitope replicated on its surface or if the developing binding material is a polyclonal antibody or 10 if more than one monoclonal antibody directed at different epitopes on the analyte is used as developing material, thus increasing the effective affinity of the developing binding material. This implies that the surface density of developing binding material molecules on the microspheres is 15 likely to represent an important determinant of the sensitivities achieved.

- 35 -

CLAIMS

1. A binding assay process in which the concentration of an analyte in a liquid sample is determined by comparison with a dose-response curve computed from standard samples,  
5 using a capture binding agent having binding sites specific for the analyte and a developing binding material capable of binding with the bound analyte or with the binding sites on the capture binding agent occupied by the bound analyte or with the binding sites remaining unoccupied  
10 on the capture binding agent,

the capture binding agent being used in an amount such that only an insignificant fraction of the analyte in the sample becomes bound to the capture binding agent, and

a label being used in the assay in relation to the  
15 developing binding material whereby the strength of the signal associated with the label is representative of the fractional occupancy of the binding sites on the capture binding agent by the analyte,

wherein there is used as the label microspheres having  
20 a size of less than 5  $\mu\text{m}$  and carrying a marker.

2. A process as claimed in claim 1, wherein the microspheres have a uniform size of 0.01 to 0.5  $\mu\text{m}$ .

3. A process as claimed in claim 1 or 2, wherein the microspheres are made of polymer latex and are provided on  
25 their surface with negatively charged or positively charged groups.

4. A process as claimed in any of claims 1 to 3, wherein the marker is a fluorescent label contained within the microspheres.

30 5. A process as claimed in claim 4, wherein the microspheres contain molecules of an oil-soluble fluorescent dye providing fluorescence in a colour range compatible with

- 36 -

a standard filter set.

6. A process as claimed in claim 4, wherein the microspheres contain molecules of a fluorescent dye having a prolonged fluorescent period such that the signal strength is capable of being determined by a time-resolved fluorescence technique.

7. A process as claimed in any of claims 1 to 6, wherein the microspheres have the developing binding material adsorbed or directly or indirectly chemically bonded to them.

8. A process as claimed in any of claims 1 to 6, wherein some of the microspheres have the developing binding material adsorbed or directly or indirectly chemically bonded to them and others of the microspheres have the capture binding agent adsorbed or directly or indirectly chemically bonded to them, the label contained in the microspheres to which the developing binding material is adsorbed or chemically bonded being different from the label in the microspheres to which the capture binding agent is adsorbed or chemically bonded.

9. A process as claimed in claim 7 or 8, wherein, after the developing binding material and where appropriate the capture binding agent have been linked to the microspheres by adsorption or covalent bonding, the microspheres are blocked to avoid their non-specific binding to other materials.

10. A process as claimed in claim 9, wherein the blocking of the microspheres is achieved by means of bovine serum albumin or other non-interfering protein material and a non-ionic detergent.

11. A process as claimed in any of claims 1 to 10,

- 37 -

wherein the capture binding agent is immobilised on a solid support in the form of one or more microspots having an area of  $1 \text{ mm}^2$  or less at a surface density in the range of 1,000 to 100,000 molecules/  $\mu\text{m}^2$ , and wherein the liquid sample size is 1 ml or less.

12. A process as claimed in claim 11, wherein the microspot or microspots have a diameter of 0.01 to 1 mm and contain immobilised capture binding agent at a surface density of 10,000 to 50,000 molecules/  $\mu\text{m}^2$ , the sample size being 50  $\mu\text{l}$  - 1 ml.

13. A process as claimed in claim 11 or 12, wherein different capture binding agents are immobilised on different microspots on the same solid support and different binding assays for the determination of different analytes in the same liquid sample are performed in the same operation.

14. A process as claimed in any of claims 1 to 13, wherein both the capture binding agent and the developing binding material are antibodies.

20 15. A process as claimed in any of claims 1 to 13, for use in DNA assays, wherein the capture binding agent is a single-stranded oligonucleotide DNA probe recognising a corresponding DNA sequence in the liquid sample and the developing binding material either is an antibody  
25 recognising only twin-stranded DNA sequences or is an oligonucleotide DNA sequence which either recognises another part of the corresponding DNA sequence in the liquid sample or recognises residual single-stranded oligonucleotide DNA probe forming the capture binding agent, the developing  
30 binding material being labelled by means of the microspheres.

16. A process as claimed in any of claims 1 to 15, wherein the binding assay is a non-competitive binding

assay.

17. A binding assay process for the detection of an analyte comprising a single-stranded DNA sequence in a liquid sample, comprising
- 5       contacting the sample in a non-competitive or competitive procedure with
- an immobilised capture binding agent which is a single-stranded oligonucleotide DNA probe capable of recognising analyte in the liquid sample and binding
- 10 therewith, and
- with a labelled developing binding material which either is an antibody capable of recognising only twin-stranded DNA sequences formed from the probe and the analyte and of binding therewith or is an oligonucleotide DNA
- 15 sequence capable of recognising and binding with either another part of the analyte or the residual probe,
- the developing binding material being labelled by means of microspheres having a size of less than 5  $\mu\text{m}$  and carrying a marker, and,
- 20       after the removal of unattached developing binding material, detecting the presence of the analyte by the existence or strength of a signal from the marker attached to developing binding material which has become bonded directly or indirectly to the immobilised capture binding
- 25 agent.

18. A process as claimed in claim 17, wherein the marker is a fluorescent label contained within microspheres having a size of 0.01 to 1  $\mu\text{m}$ .

19. A process as claimed in claim 17 or 18, wherein

30 the developing binding material is directly or indirectly covalently bonded to the microspheres.

20. A kit for use in a binding assay process in which the concentration of an analyte in a liquid sample is determined using a capture binding agent having binding



- 39 -

sites specific for the analyte and a developing binding material capable of binding with the bound analyte or with the binding sites on the capture binding agent occupied by the bound analyte or with the binding sites remaining unoccupied on the capture binding agent, a label being used in relation to the developing binding material whereby the strength of the signal associated with the label is representative of the fractional occupancy of the binding sites on the capture binding agent by the analyte, the kit comprising (a) a solid support having the capture binding agent immobilised thereon, (b) a developing reagent comprising the developing binding material adsorbed or directly or indirectly chemically bonded to the surface of microspheres carrying a marker and (c) standards having known amounts or concentrations of the analyte to be determined.

21. A kit as claimed in claim 20, wherein the reagent contains the developing binding material adsorbed onto or covalently bonded to microspheres having a size of less than 5  $\mu\text{m}$  and containing molecules of a fluorescent dye.

22. A kit as claimed in claim 20 or 21, wherein the solid support has the capture binding agent immobilised thereon in the form of one or more microspots of size less than 1  $\text{mm}^2$  and surface density at least 1000 molecules/  $\mu\text{m}^2$ .

25 23. A kit as claimed in claim 22, wherein different capture binding agents are immobilised on different microspots on the same solid support and a plurality of different developing reagents and different standards for different analytes are included.

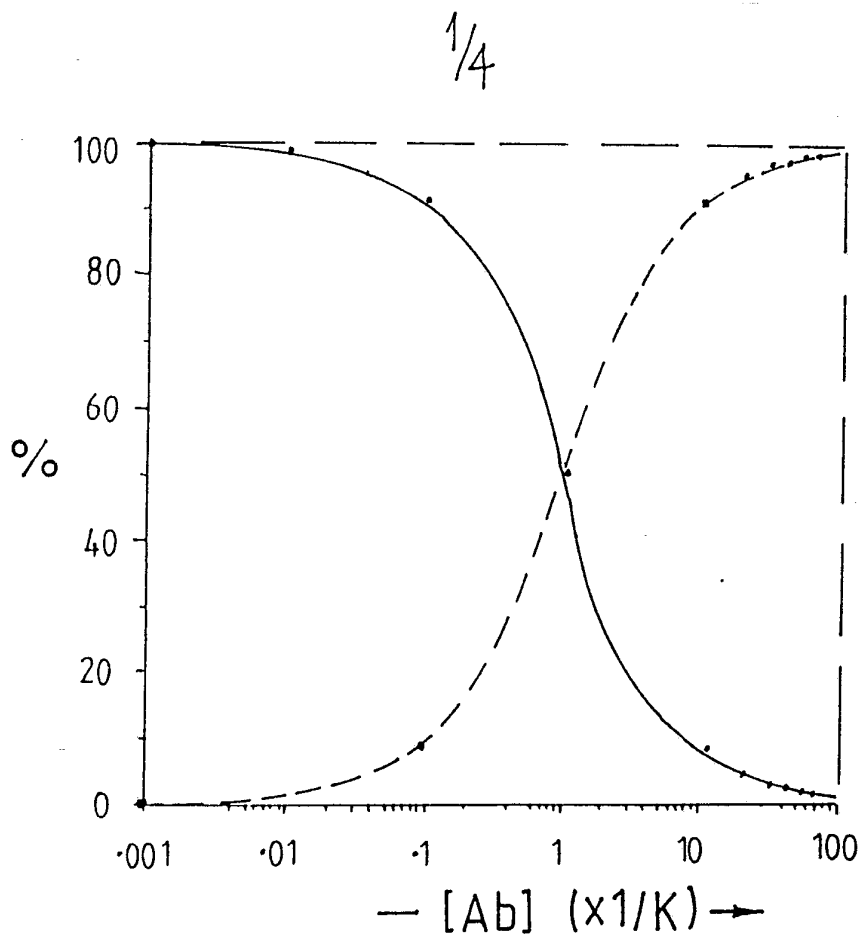

FIG. 1

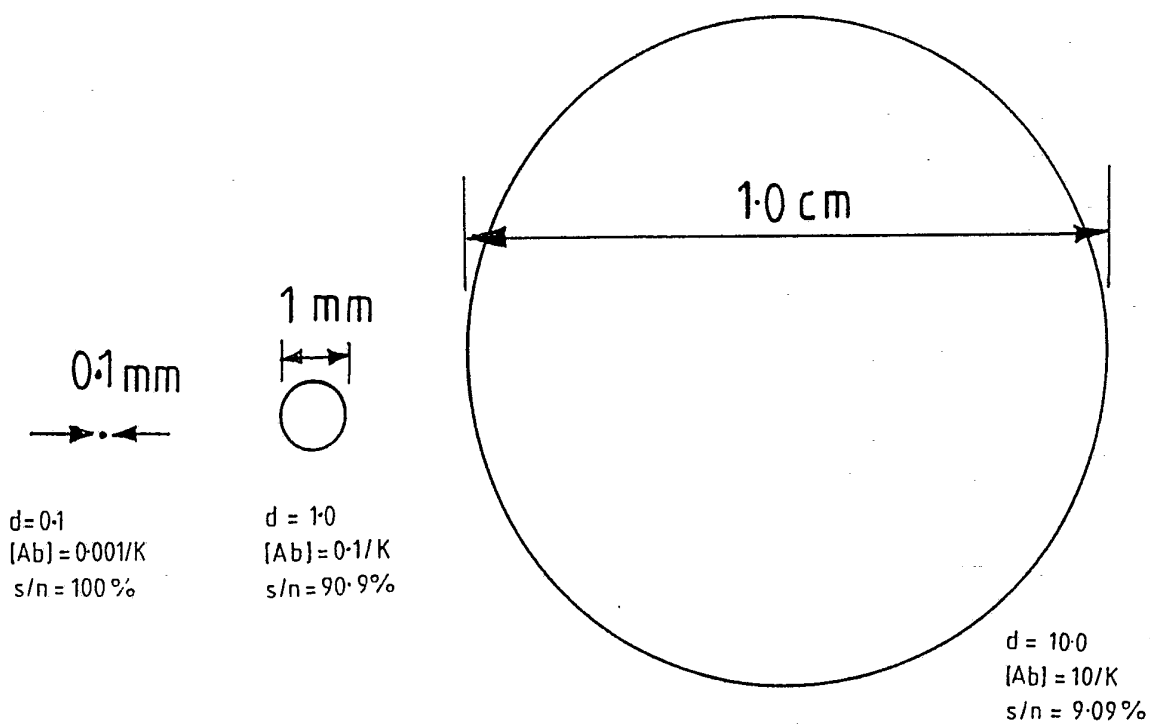

FIG. 2

FIG. 3

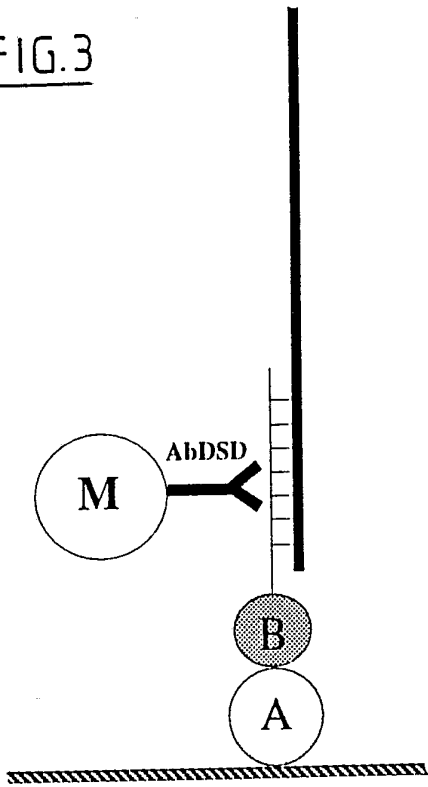

FIG. 4

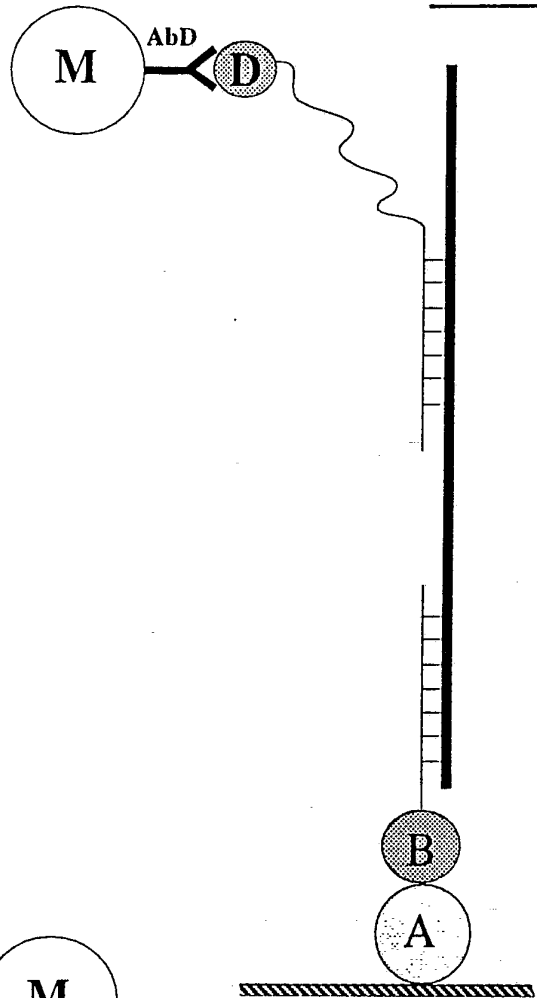
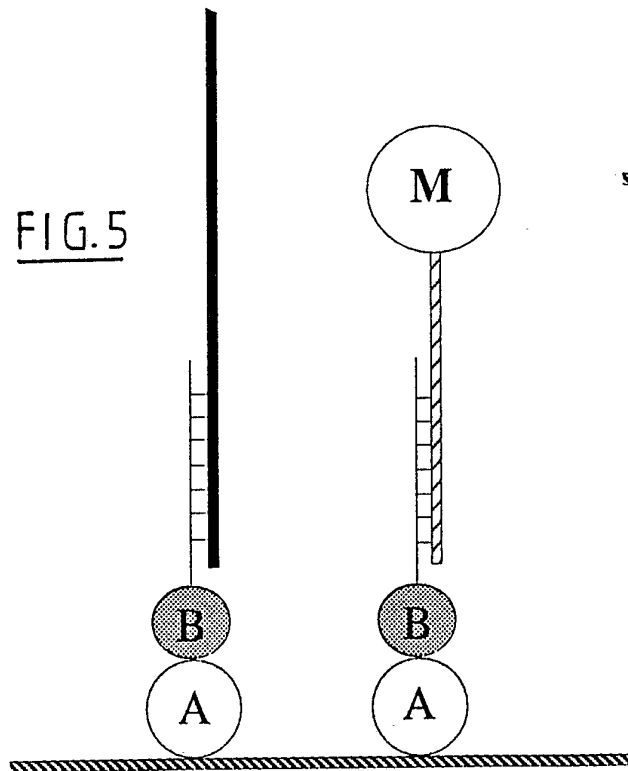

FIG. 5



3/4

FIG. 6

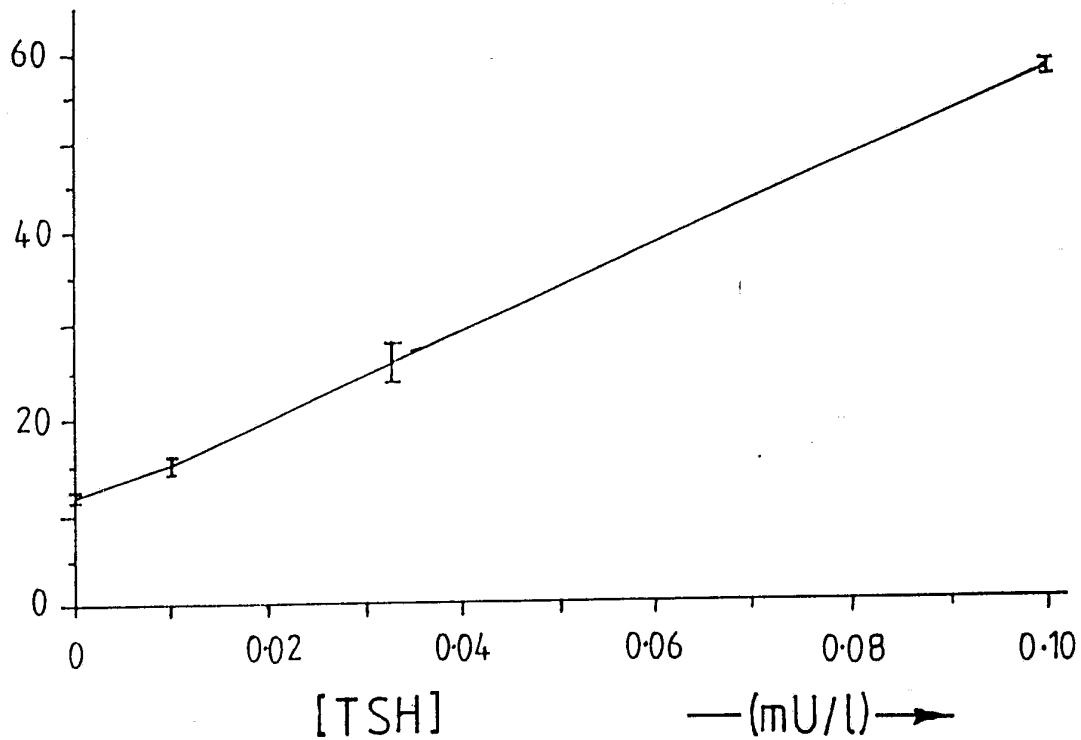
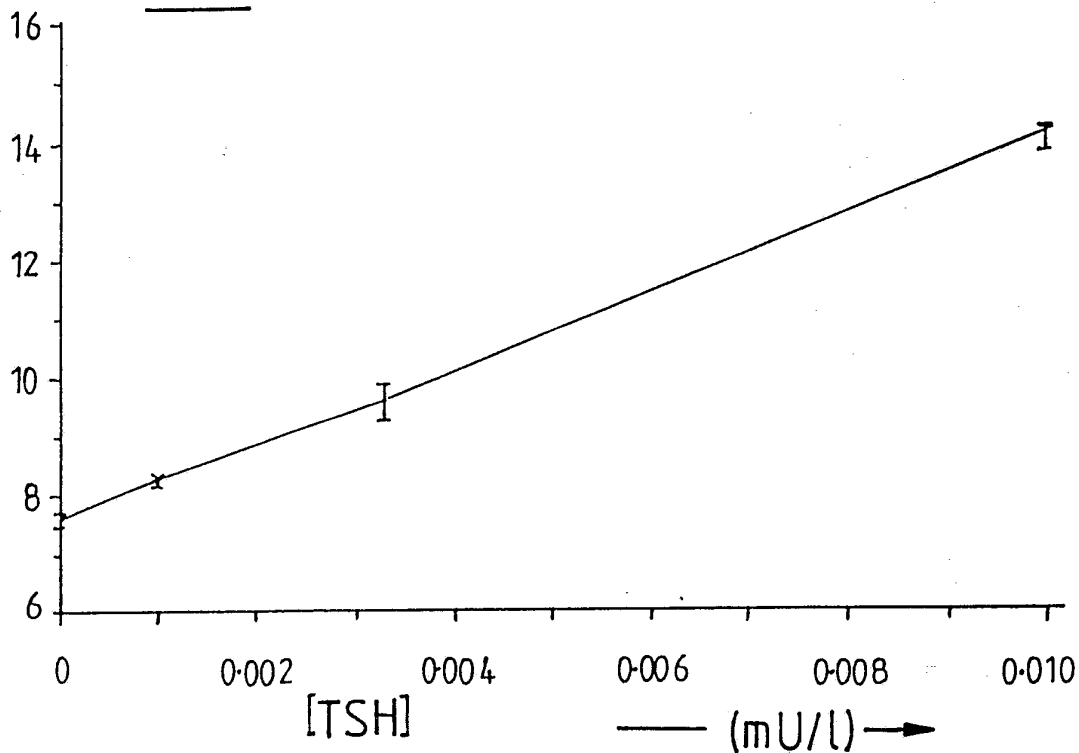
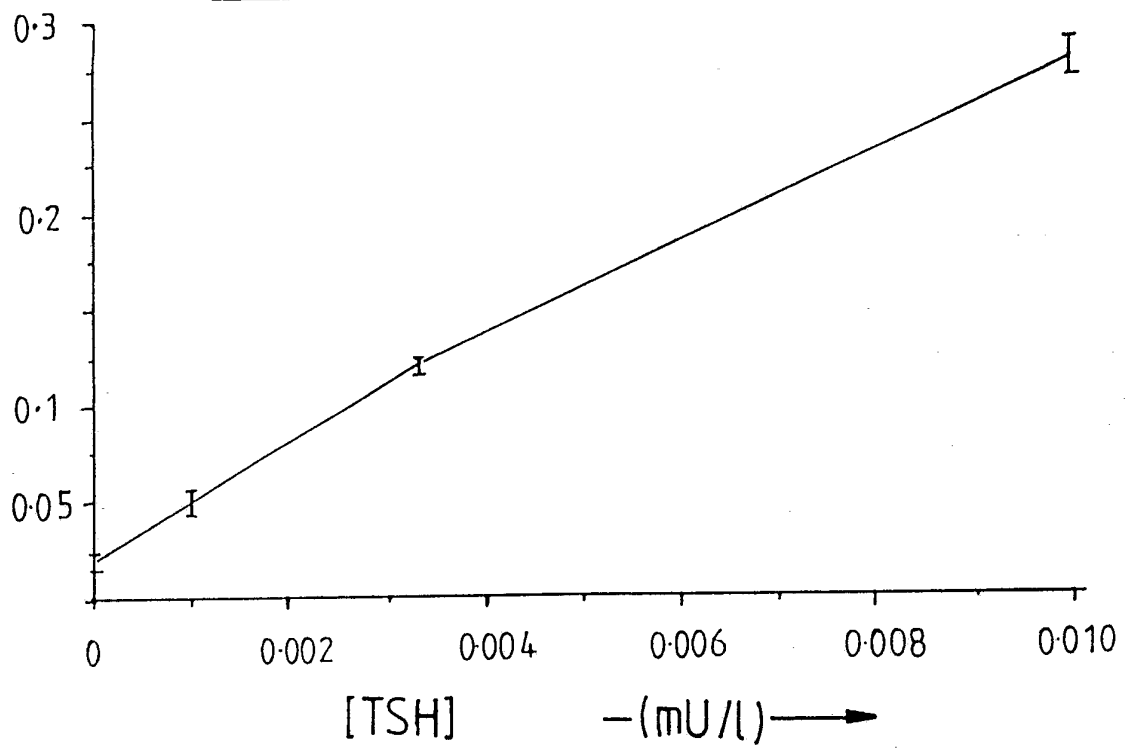

FIG. 7



4/4

FIG. 8



## INTERNATIONAL SEARCH REPORT

PCT/GB 92/01892

International Application No

I. CLASSIFICATION OF SUBJECT MATTER (if several classification symbols apply, indicate all) <sup>6</sup>		
According to International Patent Classification (IPC) or to both National Classification and IPC		
Int.Cl. 5 G01N33/543; G01N33/58; C12Q1/68		
II. FIELDS SEARCHED		
Minimum Documentation Searched <sup>7</sup>		
Classification System	Classification Symbols	
Int.Cl. 5	G01N ; C12Q	
Documentation Searched other than Minimum Documentation to the Extent that such Documents are Included in the Fields Searched <sup>8</sup>		
III. DOCUMENTS CONSIDERED TO BE RELEVANT <sup>9</sup>		
Category <sup>10</sup>	Citation of Document, <sup>11</sup> with indication, where appropriate, of the relevant passages <sup>12</sup>	Relevant to Claim No. <sup>13</sup>
X	EP,A,0 396 801 (TEIKOKU HORMONE MFG CO.,LTD) 14 November 1990 see the whole document ---	1-23
X	EP,A,0 360 088 (ABBOTT LABORATORIES) 28 March 1990 see page 3, line 40 - line 50 see page 6, line 1 - line 40; claims 10,11 ---	1-23
X	EP,A,0 301 584 (FUJIREBIO K.K.) 1 February 1989 see the whole document ---	1-23
X	EP,A,0 267 317 (PROFILE DIAGNOSTIC SCIENCES INC.) 18 May 1988 see claims 1,3 ---	1-23
		-/--
<p><sup>10</sup> Special categories of cited documents :</p> <p>"A" document defining the general state of the art which is not considered to be of particular relevance</p> <p>"E" earlier document but published on or after the international filing date</p> <p>"L" document which may throw doubts on priority claim(s) or which is cited to establish the publication date of another citation or other special reason (as specified)</p> <p>"O" document referring to an oral disclosure, use, exhibition or other means</p> <p>"P" document published prior to the international filing date but later than the priority date claimed</p> <p>"T" later document published after the international filing date or priority date and not in conflict with the application but cited to understand the principle or theory underlying the invention</p> <p>"X" document of particular relevance; the claimed invention cannot be considered novel or cannot be considered to involve an inventive step</p> <p>"Y" document of particular relevance; the claimed invention cannot be considered to involve an inventive step when the document is combined with one or more other such documents, such combination being obvious to a person skilled in the art.</p> <p>"&amp;" document member of the same patent family</p>		
IV. CERTIFICATION		
Date of the Actual Completion of the International Search		Date of Mailing of this International Search Report
29 JANUARY 1993		17.02.93
International Searching Authority		Signature of Authorized Officer
EUROPEAN PATENT OFFICE		CARTAGENA ABELLA P

III. DOCUMENTS CONSIDERED TO BE RELEVANT (CONTINUED FROM THE SECOND SHEET)		Relevant to Claim No.
Category °	Citation of Document, with indication, where appropriate, of the relevant passages	
A	WO,A,8 801 058 (R. PH. EKINS) 11 February 1988 cited in the application ---	
A	WO,A,8 901 157 (R. PH. EKINS) 9 February 1989 cited in the application ---	
A	WO,A,8 401 031 (R. PH. EKINS) 15 March 1984 cited in the application -----	

**ANNEX TO THE INTERNATIONAL SEARCH REPORT  
ON INTERNATIONAL PATENT APPLICATION NO.**

GB 9201892  
SA 65784

This annex lists the patent family members relating to the patent documents cited in the above-mentioned international search report. The members are as contained in the European Patent Office EDP file on The European Patent Office is in no way liable for these particulars which are merely given for the purpose of information. 29/01/93

Patent document cited in search report	Publication date	Patent family member(s)	Publication date
EP-A-0396801	14-11-90	JP-A- 1214760	29-08-89
		AU-B- 625455	09-07-92
		AU-A- 3453889	08-11-90
EP-A-0360088	28-03-90	AU-A- 4147989	29-03-90
		JP-A- 2116751	01-05-90
EP-A-0301584	01-02-89	JP-A- 1035373	06-02-89
EP-A-0267317	18-05-88	US-A- 4663277	05-05-87
WO-A-8801058	11-02-88	AU-B- 614935	19-09-91
		AU-A- 7755987	24-02-88
		JP-T- 1503405	16-11-89
		CA-A- 1284620	04-06-91
		EP-A- 0271974	22-06-88
		EP-A- 0318491	07-06-89
		US-A- 5171695	15-12-92
WO-A-8901157	09-02-89	AU-A- 2253488	01-03-89
		DE-A- 3872621	13-08-92
		EP-A, B 0304202	22-02-89
		EP-A- 0375700	04-07-90
		JP-T- 3503081	11-07-91
WO-A-8401031	15-03-84	AU-A- 1944283	29-03-84
		EP-A, B 0134215	20-03-85
		JP-T- 59501480	16-08-84