

Dec. 27, 1932.

J. E. CARR

1,892,446

LATCH MECHANISM

Filed May 1, 1930

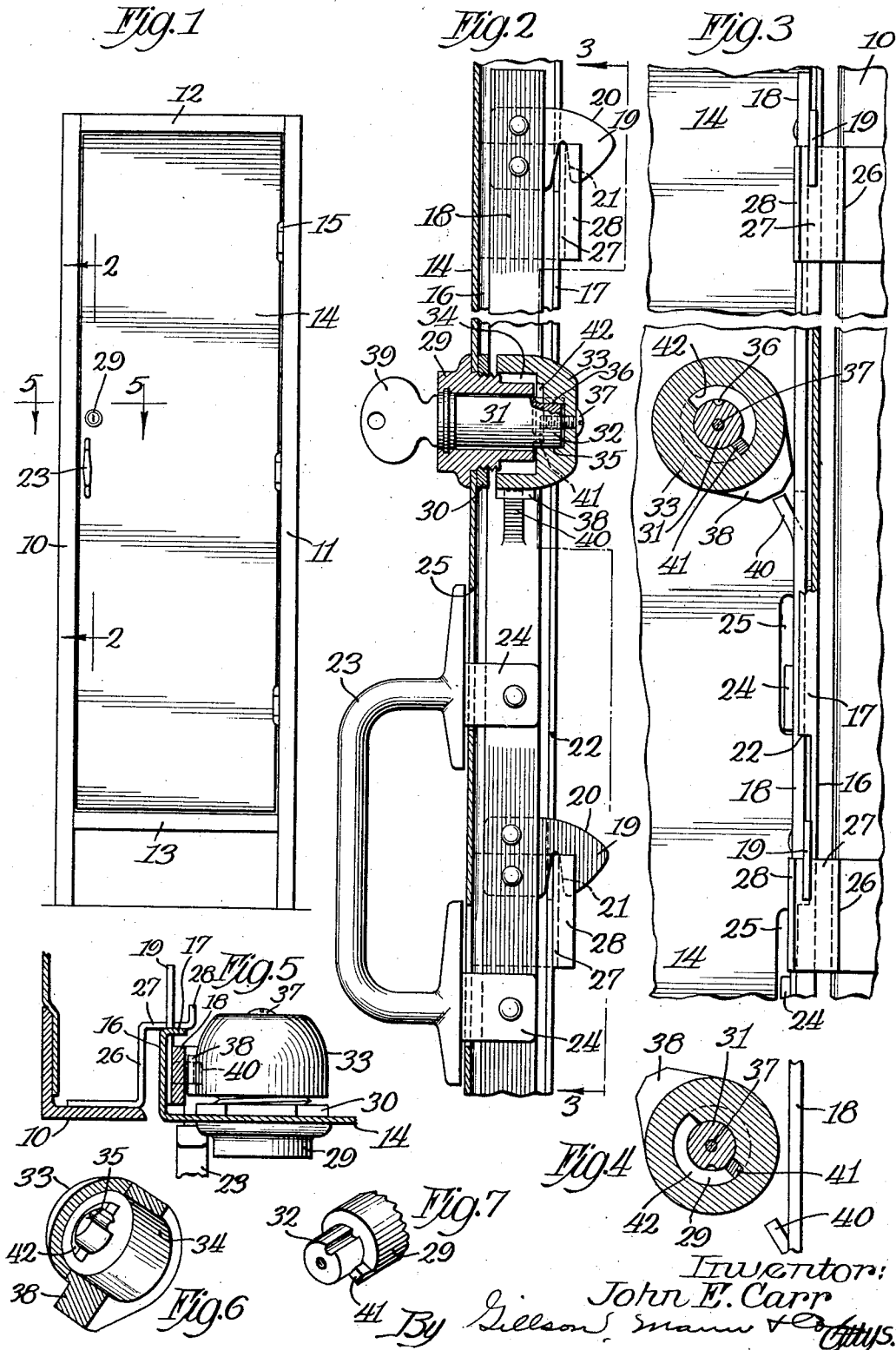

Inventor:
John E. Carr
By Gilson, Mann & Coys.

UNITED STATES PATENT OFFICE

JOHN E. CARR, OF AURORA, ILLINOIS, ASSIGNOR TO ALL-STEEL-EQUIP COMPANY,
A CORPORATION OF ILLINOIS

LATCH MECHANISM

Application filed May 1, 1930. Serial No. 448,906.

The principal object of this invention is to provide a reliable latch mechanism of simplified and improved design.

Other and further objects and advantages will become apparent as the disclosure proceeds and the description is read in connection with the accompanying drawing, in which

Fig. 1 is a front, elevational view of a locker embodying the latch mechanism of this invention;

Fig. 2 is a vertical, sectional view taken through the lock on the line 2—2 of Fig. 1;

Fig. 3 is a vertical, sectional view taken on the line 3—3 of Fig. 2 and showing the latch bar locked against movement;

Fig. 4 is a view illustrating the relative position of the cam and latch bar when the door is unlocked;

Fig. 5 is a horizontal, sectional view taken through one of the corner posts on the line 5—5 of Fig. 1;

Fig. 6 is a perspective view of the cam; a part of which is broken away to illustrate the interior; and

Fig. 7 is a perspective view of the lock barrel and lock plug showing them in their assembled relation.

But this illustration and the corresponding specific description are for the purpose of disclosure only and are not intended to limit the scope of the invention beyond that required by the prior art.

A conventional locker has been used to illustrate an application of this invention, although it will be understood that the invention may be advantageously used in many other environments.

The locker is of the usual sheet metal construction having angle uprights 10, 11 and cross channels 12, 13. A door 14 is hinged at 15 to the upright 11 and has its edges turned inwardly at 16 and rearwardly at 17, thus forming a U-shaped reinforcing flange or channel.

Slidably mounted within the channel at the free edge of the door is a latch bar 18 to which a plurality of catches 19 are riveted at intervals along the bar. The heads of the catches are tapered at 20 to a blunt point

and notches 21 are cut into their lower edges. The catches pass through elongated slots 22 in the wall 17 of the channel and thus limit the latch bar to a given up and down movement.

A handle 23 having arms 24 riveted to the latch bar and passing through suitable slots 25 in the door panel is provided to control the movement of the latch bar.

Secured to the upright 10 is a door jamb 26 of angular form having lugs 27 extending parallel to the front web of the upright and offset therefrom a distance which brings the face of the door flush with the upright when the door is in its latched position. These lugs are situated at intervals corresponding to the catches on the latch bar and cooperate with the latter to latch the door. Inasmuch as the heads of the catches are tapered, it is not necessary in closing the door to raise the handle since the latch bar will be automatically raised when the catches strike the lugs. The notches, of course, prevent the door from being opened until the latch bar is raised. Preferably the ends of the lugs are bent inwardly at 28 in order to prevent the door from being jimmied open.

A tumbler lock is fitted to the door preferably above the handle, and comprises a lock barrel 29 which is held in place by a securing nut 30. A lock plug 31 is rotatably mounted within the barrel and is of general cylindrical form. As seen in Fig. 7, the head 32 of the lock plug projects a short distance beyond the lock barrel.

A cup-shaped cam 33 having a large bore 34 and a small or head bore 35 is splined at 36 to the lock plug and held in place by a screw 37. The large bore 34 is of sufficient diameter to clear the lock barrel. One side of the cam is thickened at 38, thus providing a cam arm.

When the proper key 39 is inserted in the lock, the plug may be rotated, carrying with it the cam. When in the position shown in Fig. 3, the cam arm 38 forms an obstruction to a finger 40 struck from the latch bar, thus preventing the bar from being raised. Upon rotating the cam to some other position, such as the one shown in Fig. 4, the ob-

struction is removed and the latch bar may be raised to open the door. Means must be provided to limit the rotation of the lock plug to 180°, otherwise it would cause considerable inconvenience in inserting and removing the key from the lock. To this end, a boss 41 is provided on the lock barrel which travels within a semi-circular marginal groove 42 in the cam head. As clearly seen in Figs. 4 and 5, the groove 42 is slightly more than a semi-circle in order to account for the thickness of the boss.

It will be noticed that in the construction just described, the cam arm acts directly upon the latch bar to effect a locking of the door. This eliminates all needless parts and provides a construction which is inexpensive to manufacture and which is not likely to get out of order. Even if something does go wrong with the mechanism, it is very easy to get at the moving parts simply by removing the screw 37 and taking off the cam.

It is, of course, apparent that this invention is not limited to the exact form of cam shown, the gist of this invention being to secure a locking of the latch bar by a rotatable cam directly engaging the latch bar.

I claim:

1. In a device of the class described, a door, a rotatable lock plug, a single gravity operative latch bar vertically movable with respect to the door, a cup-shaped cam secured to the end of the lock plug, means for limiting the rotation of the lock plug and cam to a given angle, and a finger on the latch bar engageable with the cam arm when in locked position but free from obstruction when the cam arm is in unlocked position.

2. In a device of the class described, a door, a gravity operative latch bar vertically movable with respect to the door, a handle secured to the bar, a lock in the door adjacent the latch bar including a rotatable lock plug, a finger struck from the bar and projecting in the direction of the lock, said lock including a detachable cam secured to the head of the lock plug and adapted to be moved into the path of the finger to prevent the bar from being raised.

3. In a device of the class described, a door, a single gravity operative latch bar vertically movable with respect to the door, a handle secured to the bar, a lock in the door adjacent the latch bar including a rotatable lock plug, a finger projecting from the bar in the direction of the lock, said lock including a detachable cam secured to the head of the lock plug and adapted to be moved into the path of the finger to prevent the bar from being raised, and means limiting rotation of the cam to a predetermined angle.

4. In a device of the class described, a door, a single flattened latch bar vertically movable with respect to the door, a plurality of catches on the bar, a handle secured to the

bar, a lock in the door adjacent the latch bar including a rotatable lock plug, a finger projecting from the bar in the direction of the lock, said lock including a stop, means for securing the stop to said head, said stop adapted to be moved into the path of the finger to prevent the bar from being raised.

5. In a device of the class described, the combination of a door, a single gravity operative latch bar vertically movable with respect to the door, a handle secured to the latch bar, a rotatable lock plug secured to the door adjacent the latch bar, a cam clamped to the lock plug head and rotatable therewith, and a finger projecting from the latch bar adapted to engage the cam and hold the latch bar against movement when the cam is in one position but adapted to clear the cam and permit free movement of the latch bar when the cam is in another position.

6. In a device of the class described, the combination of a door, a single gravity operative latch bar vertically movable with respect to the door, a handle secured to the latch bar, a rotatable lock plug secured to the door adjacent the latch bar, a cam clamped to the lock plug head and rotatable therewith, and a finger projecting from the latch bar adapted to engage the cam and hold the latch bar against movement when the cam is in one position but adapted to clear the cam and permit free movement of the latch bar when the cam is in another position, and means to limit rotation of the cam to a given angle.

In testimony whereof I affix my signature.
JOHN E. CARR.