

G. C. BREON.
 TABLE SLIDE.
 APPLICATION FILED JAN. 12, 1914.

1,123,673.

Patented Jan. 5, 1915.

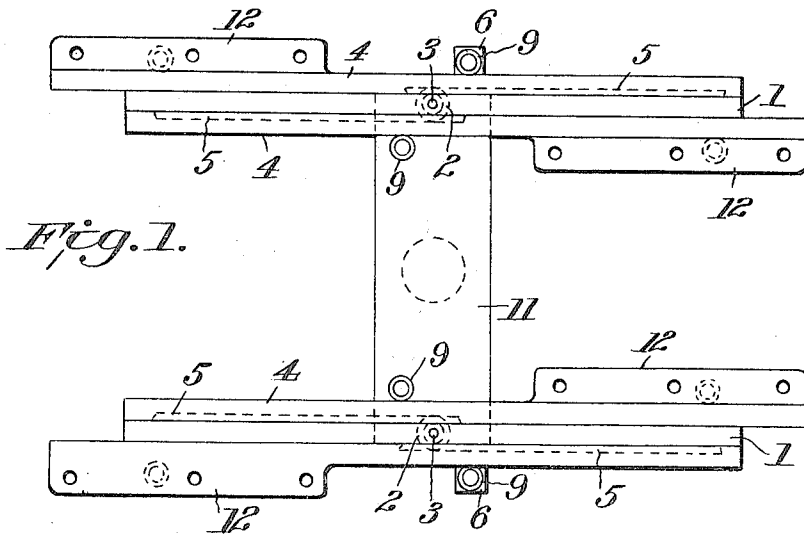

Fig. 1.

Fig. 2.

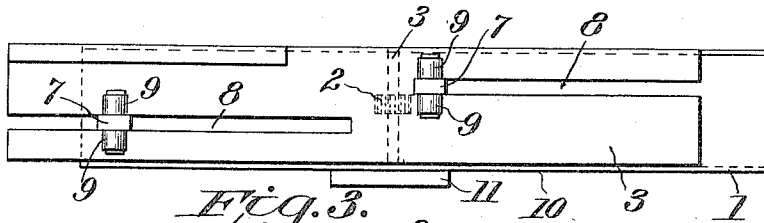

Fig. 3.

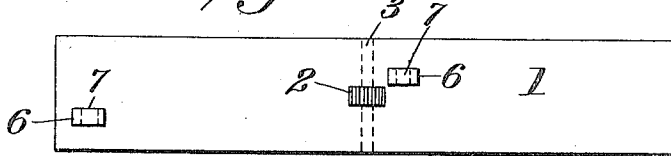

Fig. 4.

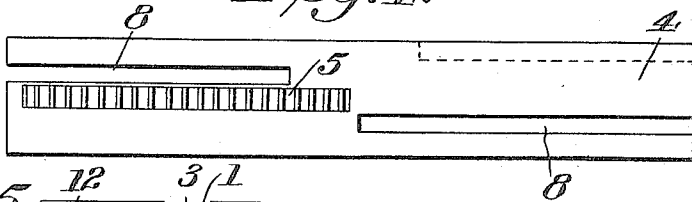
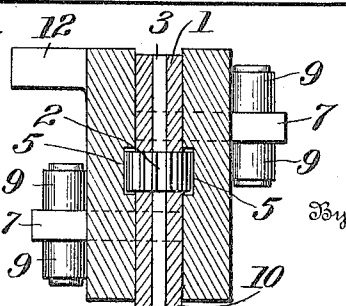

Fig. 5.

Witnesses
Chas. Walker
Robt. Watson



Inventor
George C. Breon.
 C. W. Clement
 Attorney

UNITED STATES PATENT OFFICE.

GEORGE C. BREON, OF SUNBURY, PENNSYLVANIA.

TABLE-SLIDE.

1,123,673.

Specification of Letters Patent.

Patented Jan. 5, 1915.

Application filed January 12, 1914. Serial No. 811,744.

To all whom it may concern:

Be it known that I, GEORGE C. BREON, a citizen of the United States, residing at Sunbury, in the county of Northumberland and State of Pennsylvania, have invented certain new and useful Improvements in Table-Slides, of which the following is a specification.

This invention relates to improvements in table slides, and has for its object the arrangement and construction of an efficient slide that will at the same time be economical to manufacture. It may be made wholly of wood, wholly of metal, or of both wood or metal. Its principal feature is a rack and pinion device whereby the table may be caused to open in the center for the reception of boards by simply pulling on one section of the table top.

The various features of the invention will be hereinafter more fully described in connection with the accompanying drawing; in which;—

Figure 1, is a top plan view of the improved slide as shown when fastened to the bottom of a table top with pedestal bridge attached. Fig. 2, is a side elevation of one of the exterior sections showing retaining rollers. Fig. 3, is a side elevation of the central section showing pinion interposed. Fig. 4, is a side elevation of the inside of one of the exterior sections showing rack. Fig. 5, is a vertical sectional view of the slide showing the pinion in engagement with the racks.

Referring to the drawing, 1 indicates the central section of the slide in the center of which is secured a pinion 2 by means of pivot 3, said pinion projecting equal distances on both sides of said section.

4 indicates the exterior sections of the slide, each section being provided with a rack integral therewith which meshes with the pinion 2 of the section 1.

Secured in openings 6 of sections 1 in any suitable manner are studs 7 which extend through longitudinal slots 8 of section 3 on the ends of which are pivotally secured, rollers

9 which engage the exterior sides of the sections 3 and hold them into engagement with section 1. The slots 8 extend from the ends of the sections 3 to within an inch of the longitudinal center of the section and are disposed above and below the racks 5.

The center section 1 is placed slightly lower than the other sections as shown at Fig. 5 so that the bridge 11 of the pedestal may be secured to section 1 without binding on the sections 4. Integrally therewith or separately attached to the sections 4 are lugs for the purpose of securing the slides to the under side of the table top.

The particular arrangement of parts as described makes a very efficient and simply constructed slide. By pulling on one top section, the two sections of the slide fastened to that particular top section engage the pinion of the central slide section, which pinion in turn causes the slide sections attached to the other table top section to be moved in the opposite direction. The arrangement of the studs in the slots limits the length to which the slide may be opened by abutting against the ends of the slots.

Having described my invention what I claim as new and desire to obtain by Letters Patent is:—

In an extension table slide comprising a plurality of sections, one of said sections having a pinion interposed in its center adapted to be engaged by a section on each side, said outside sections provided with an integral horizontal rack adapted to engage the pinion in the central section, retaining and guiding devices comprising pins attached to the central section protruding through longitudinal slots at the top and bottom of the exterior sections provided with rollers on the end of same bearing against said exterior sections.

In testimony whereof I affix my signature in presence of two witnesses.

GEORGE C. BREON.

Witnesses:

JOHN NEISER BASSLER,
C. W. CLEMENT.