

Aug. 27, 1968

K. NIMTZ ETAL

3,398,518

TWO-FOR-ONE TWISTING MACHINE

Filed Feb. 14, 1967

10 Sheets-Sheet 1

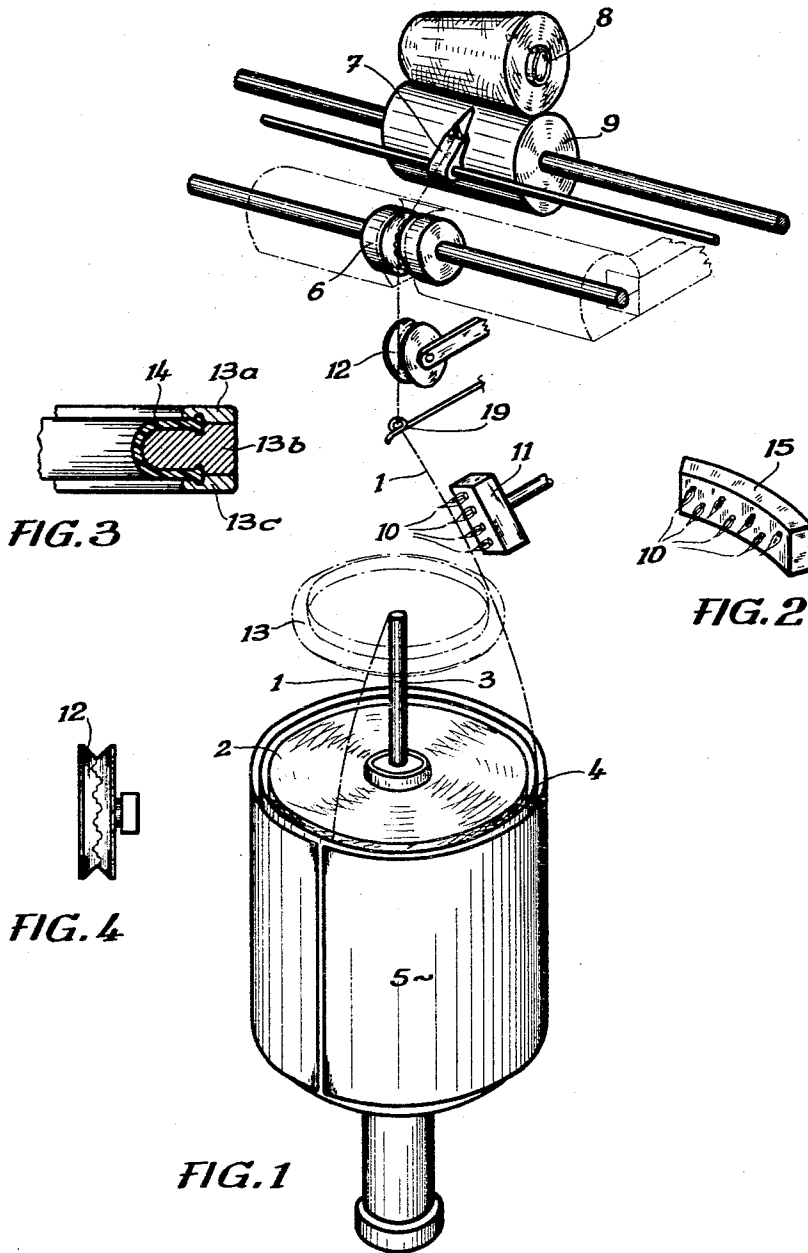

Aug. 27, 1968

K. NIMTZ ETAL

3,398,518

TWO-FOR-ONE TWISTING MACHINE

Filed Feb. 14, 1967

10 Sheets-Sheet 2

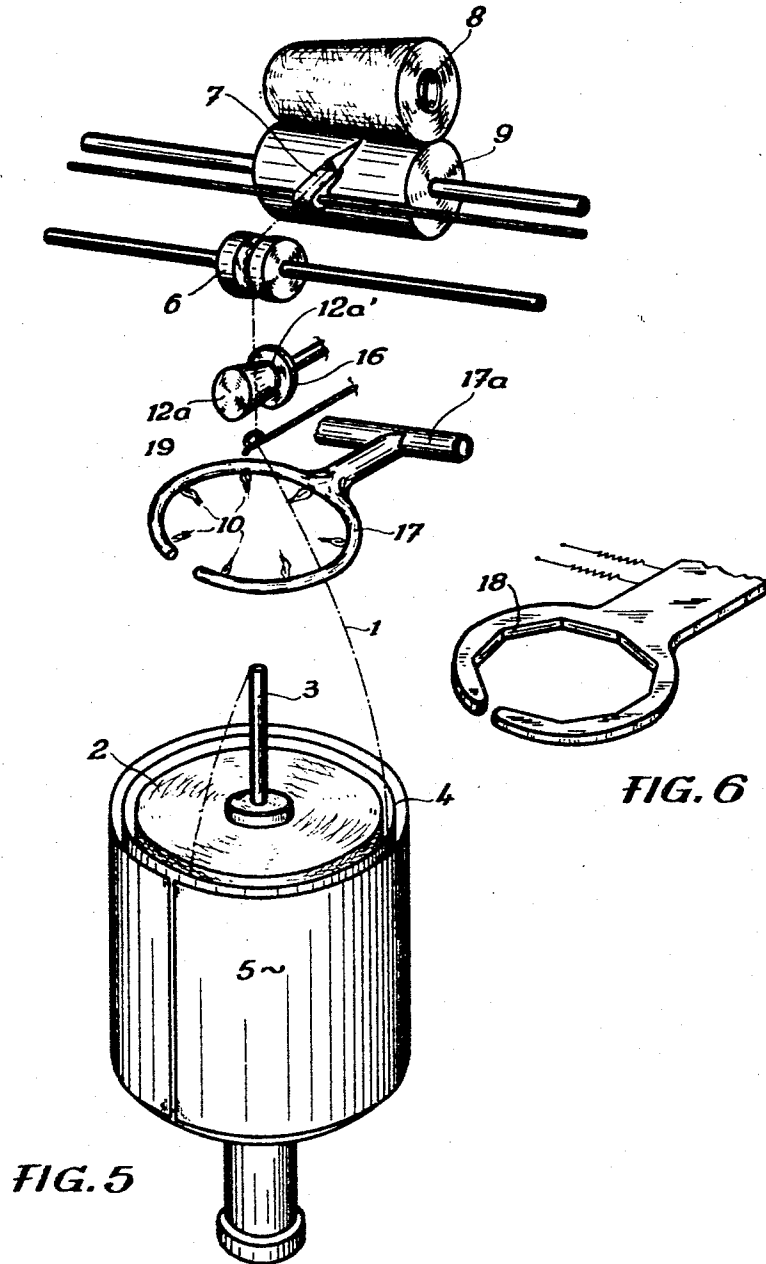

Aug. 27, 1968

K. NIMTZ ETAL

3,398,518

TWO-FOR-ONE TWISTING MACHINE

Filed Feb. 14, 1967

10 Sheets-Sheet 3

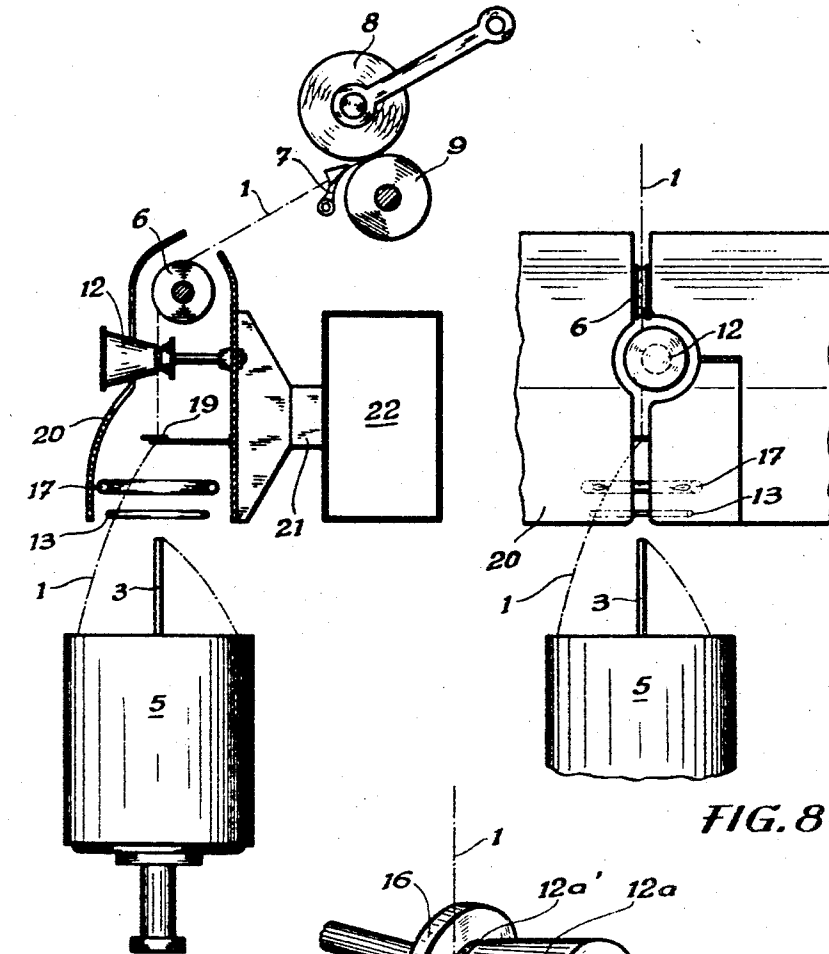

FIG. 7

FIG. 8

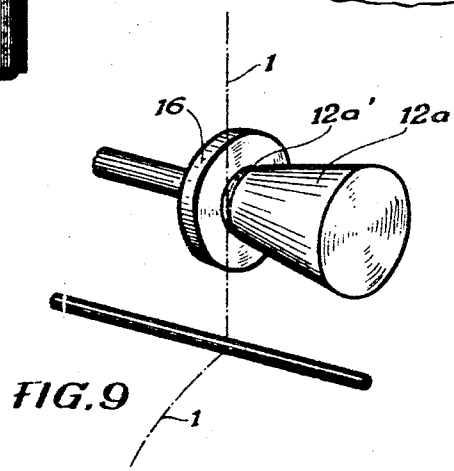

FIG. 9

Aug. 27, 1968

K. NIMTZ ETAL

3,398,518

TWO-FOR-ONE TWISTING MACHINE

Filed Feb. 14, 1967

10 Sheets-Sheet 4

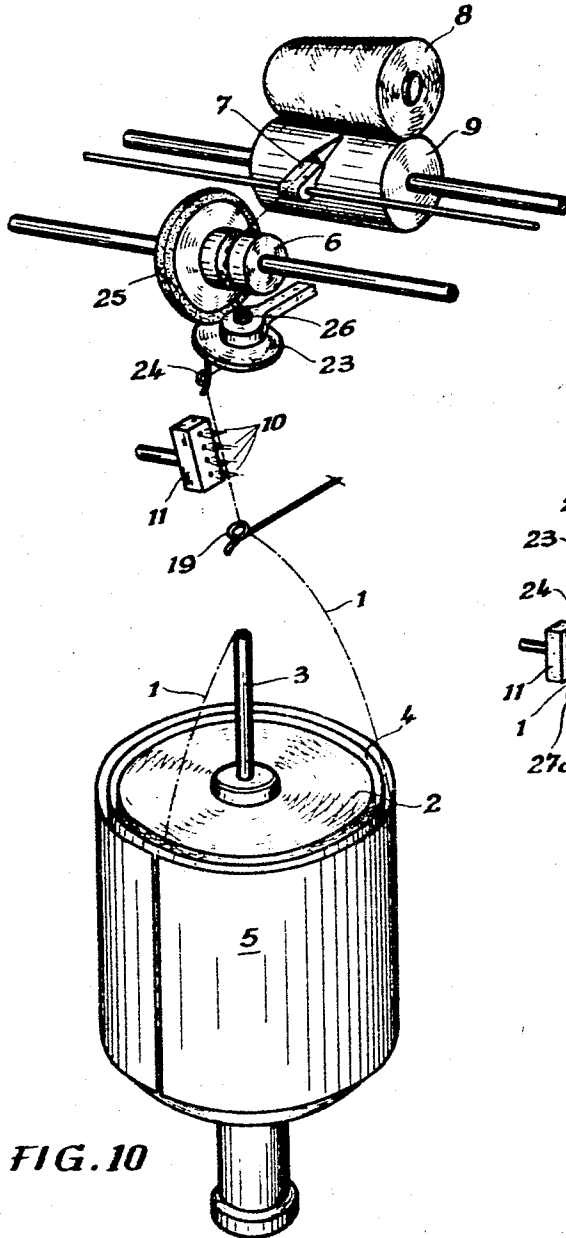

FIG. 10

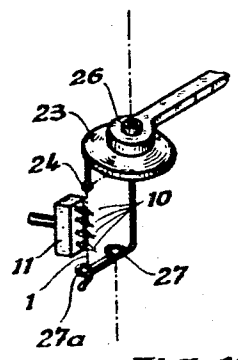

FIG. 11

Aug. 27, 1968

K. NIMTZ ETAL

3,398,518

TWO-FOR-ONE TWISTING MACHINE

Filed Feb. 14, 1967

10 Sheets-Sheet 5

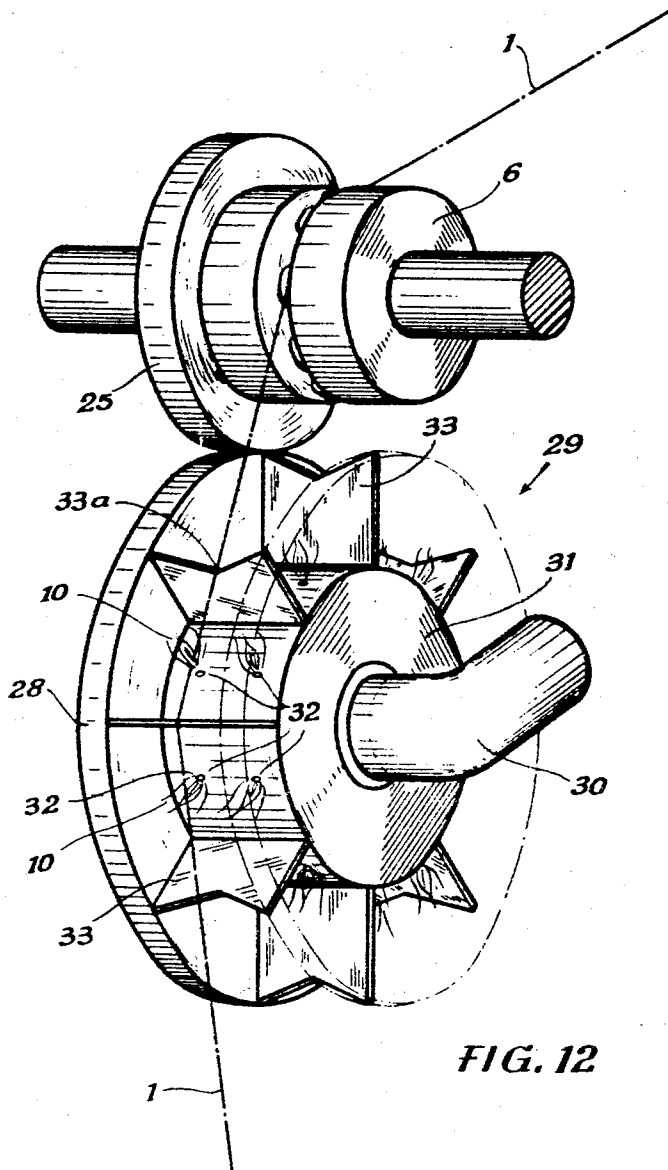

FIG. 12

Aug. 27, 1968

K. NIMTZ ETAL

3,398,518

TWO-FOR-ONE TWISTING MACHINE

Filed Feb. 14, 1967

10 Sheets-Sheet 6

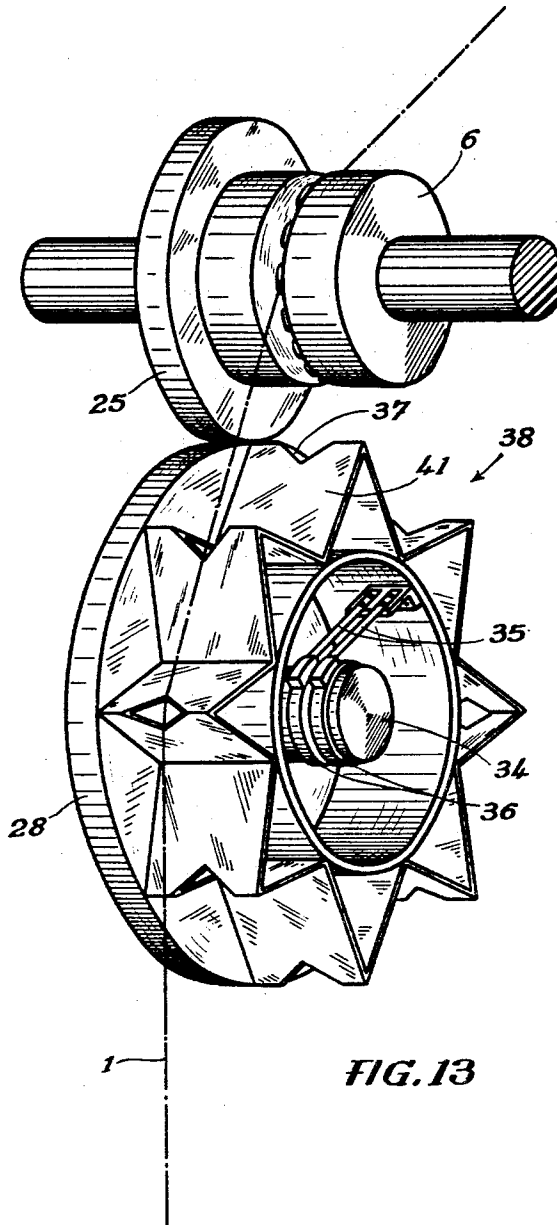

FIG. 13

Aug. 27, 1968

K. NIMTZ ET AL

3,398,518

TWO-FOR-ONE TWISTING MACHINE

Filed Feb. 14, 1967

10 Sheets-Sheet 7

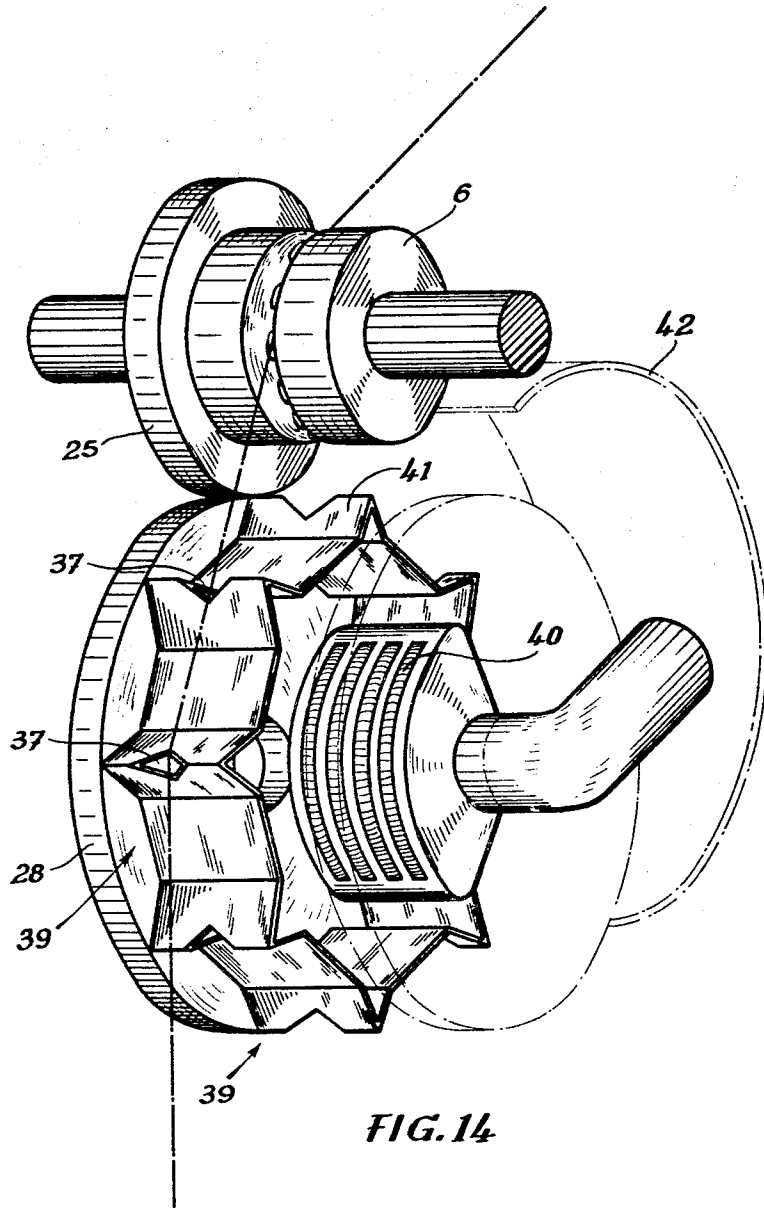

FIG. 14

Aug. 27, 1968

K. NIMTZ ETAL

3,398,518

TWO-FOR-ONE TWISTING MACHINE

Filed Feb. 14, 1967

10 Sheets-Sheet 8

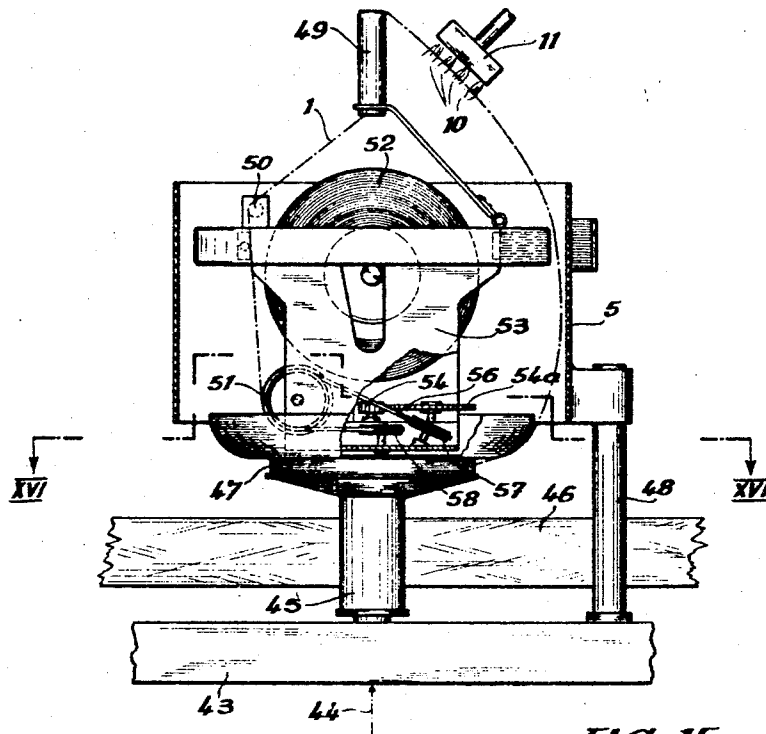

FIG. 15

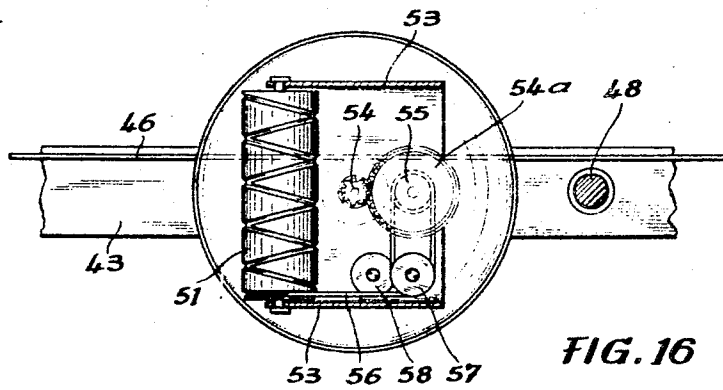

FIG. 16

Aug. 27, 1968

K. NIMTZ ETAL

3,398,518

TWO-FOR-ONE TWISTING MACHINE

Filed Feb. 14, 1967

10 Sheets-Sheet 9

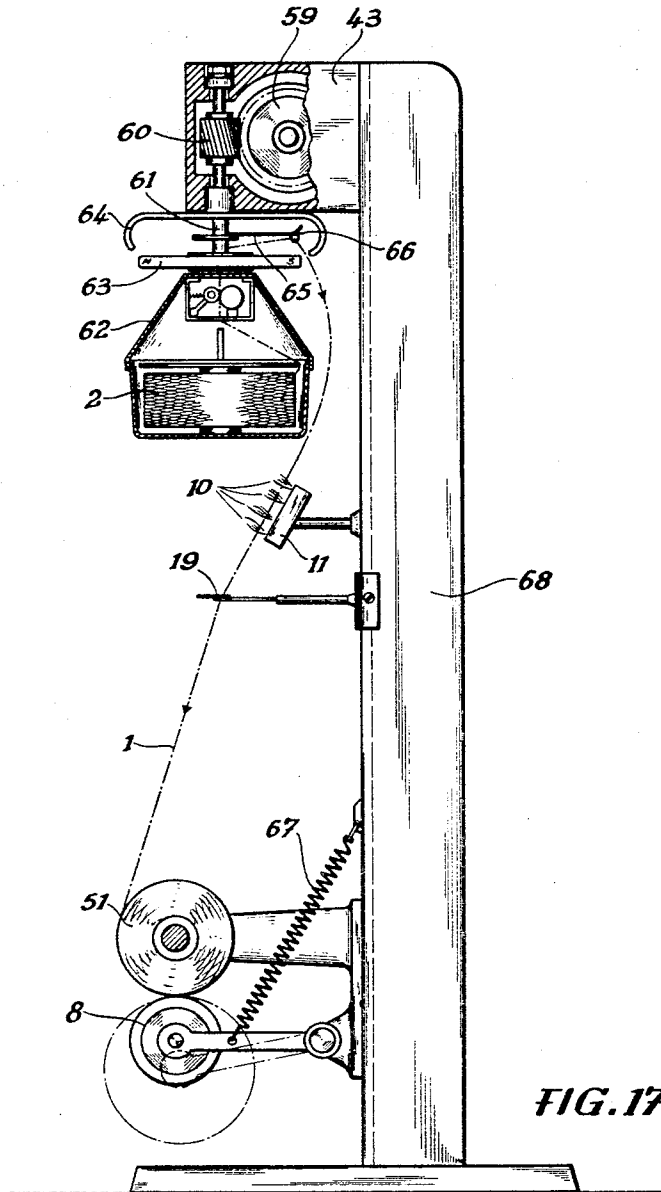

Aug. 27, 1968

K. NIMTZ ETAL

3,398,518

TWO-FOR-ONE TWISTING MACHINE

Filed Feb. 14, 1967

10 Sheets-Sheet 10.

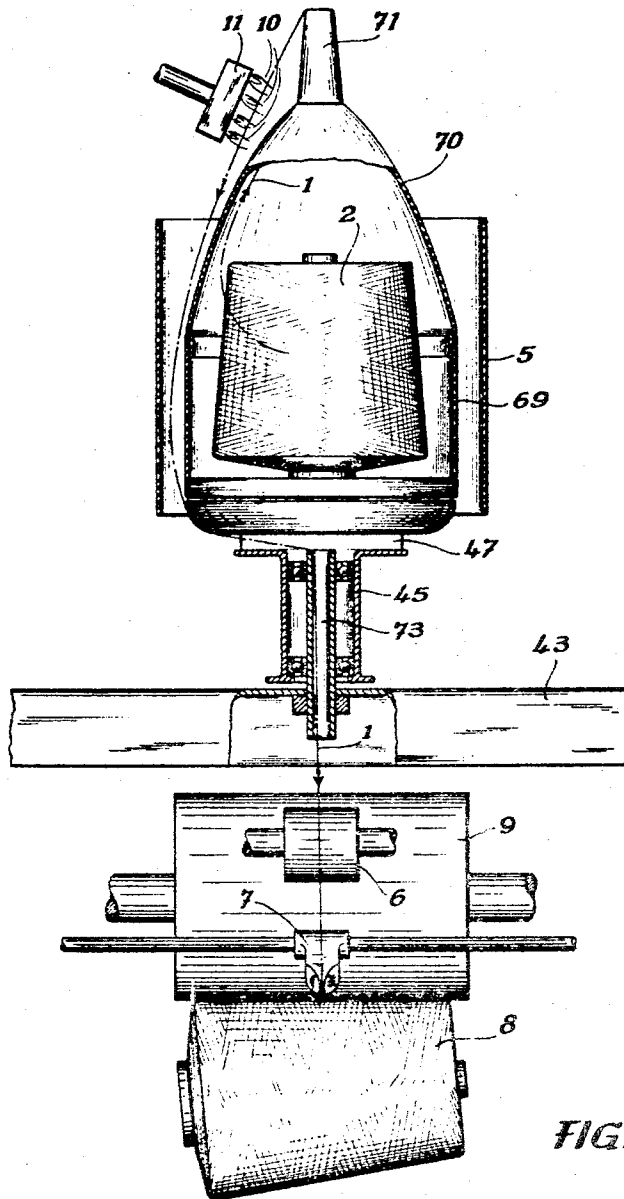

FIG. 18

1

2

3,398,518

TWO-FOR-ONE TWISTING MACHINE

Klaus Nimtz, Krefeld, and Gustav Franzen, Neersen, near Krefeld, Germany, assignors to Palitex Project-Company G.m.b.H., Krefeld, Germany

Filed Feb. 14, 1967, Ser. No. 616,002

Claims priority, application Germany, Feb. 21, 1966,

P 38,825

19 Claims. (Cl. 57—34)

ABSTRACT OF THE DISCLOSURE

The present invention concerns a two-for-one twisting machine having incorporated therein singeing means located on the path of the thread from the delivery bobbin to a winding-up spool, the arrangement being such that the thread portions passing by the singeing means in addition to the advancing movement from said bobbin to said spool carry out a movement relative to the singeing means either transverse or in the opposite direction with regard to the said singeing means.

The present invention relates to a two-for-one twisting machine. Many yarn types have to meet the requirement that they have a uniform and smooth surface for further processing. In order to obtain such uniform and smooth surfaces, so-called yarn singeing machines are employed by means of which the little textile fibers are singed off which following the spinning or twisting steps still adhere to the yarn and/or stand off from the yarn. In the said yarn singeing machines, the yarn is subjected to a special or additional respooling operation.

The singeing requires that the yarn passes by the singeing device of the singeing machine at a relatively high speed for instance at 150 meters per minute, said yarn singeing device operating with open flames or with electrically heated heating surfaces for singeing off the protruding fiber tips. This high speed is the reason why the singeing is carried out in special machines which will assure a thread passage at such high speeds.

It is an object of the present invention to provide an arrangement which will make it possible to singe the threads directly during the twisting of the threads in a two-for-one twisting machine, so that special singeing machines will not be necessary.

It is another object of this invention to provide an arrangement as set forth in the preceding paragraph which will make a special respooling operation outside the two-for-one twisting machine superfluous.

These and other objects and advantages of the invention will appear more clearly from the following specification in connection with the accompanying drawings, in which:

FIG. 1 diagrammatically illustrates a two-for-one twisting spindle with a singeing device and subsequent winding-up device.

FIG. 2 is a modified singeing device.

FIG. 3 shows a partial section through a balloon ring according to FIG. 1 but on a larger scale than in the latter.

FIG. 4 is a pulley forming a thread stripping device.

FIG. 5 is a view similar to that of FIG. 1 but differing from the latter in that the singeing device is in the form of a burner ring.

FIG. 6 shows a singeing device formed by an electrically heated ring.

FIG. 7 illustrates in side view and partly in section the embodiment of FIG. 5 with a thread passage housing engaging the singeing device.

FIG. 8 shows a front view of the embodiment of FIG. 7 within the range of the thread passage housing.

FIG. 9 is a perspective view on a larger scale than that of FIG. 7 of the thread stripper shown in FIGS. 5, 7 and 8.

FIG. 10 is a diagrammatic illustration of a two-for-one twisting spindle with singeing device and subsequent thread winding device, FIG. 10 differing from that of FIG. 1 primarily in that it employs rotating thread guide means.

FIG. 11 is a slight modification over a portion of FIG. 10.

FIG. 12 is a perspective view of a singeing device in the form of a rotating wheel, with radially directed singeing flames.

FIG. 13 shows a singeing device in the form of a wheel with radially directed electric heating surfaces.

FIG. 14 shows a singeing device in the form of a wheel ring which is rotatable about a stationarily arranged heating device.

FIG. 15 diagrammatically illustrates partially in section a two-for-one twisting spindle with a delivery bobbin arranged below the spindle rail and with a winding-up spool arranged above the spindle rail in the spindle rotor and provided with traversing means.

FIG. 16 is a section through the spindle of FIG. 15, said section being taken along the line XVI—XVI of FIG. 15.

FIG. 17 diagrammatically illustrates partially in section a further embodiment of a two-for-one twisting spindle with a spindle rotor above the delivery bobbin and with a singeing device below the delivery bobbin.

FIG. 18 diagrammatically illustrates partially in section a two-for-one twisting spindle in which the thread delivered by the delivery bobbin enters the spindle rotor radially from the outside.

The present invention is characterized primarily in that each spindle of a two-for-one twisting machine has the twisting path of the thread from the delivery bobbin to the winding-up spool associated with a singeing device for singeing the fiber tips protruding from the thread, while the arrangement is such that the thread and that section of the singeing device which faces the thread move relative to each other so as to cross each other or to move in opposite direction with regard to each other. In this way, the thread will move relative to the singeing device at a speed as is customary with separate thread singeing machines and which well exceeds the withdrawing speed at which the thread is being withdrawn from the delivery bobbin.

In order to obtain the relative movement between the thread on one hand and the singeing device on the other hand, it is possible according to one embodiment of the invention to impart a balloon or cylindrical movement upon that thread section which is acted upon by the singeing device and to do this in such a way that the thread will at intervals pass by the singeing device in a transverse direction. In this way, a certain thread section will pass by the singeing device for only a short period and only once in the transverse direction while during the next thread rotation a succeeding thread section will pass by the singeing device. Each thread section thus only once and very shortly comes into the range of the singeing device which, however, is sufficient to singe off protruding fiber tips without damaging the thread itself by singeing.

More specifically, within the range of the singeing device there may be provided a rotating thread guiding means which deviates the thread several times in such a way that the thread section passing by the singeing device circumscribes a cylinder.

The thread guiding device according to the invention may be driven by means of a friction disc rotating together with the running-ahead roller so that the drive of

3

said roller will simultaneously impart a rotating movement upon the thread guiding means.

According to a further embodiment of the invention, the singeing device may be designed in the form of a ring extending around the thread balloon or the cylinder circumscribed by said thread while singeing flames are distributed around said ring. With this embodiment, the circulating thread will with succeeding sections pass by the various singeing flames while each thread section will come into the effective area of a singeing flame only once because the thread rotates not only along a circle about the spindle axis but simultaneously carries out a movement in the axial direction.

The same operation can be realized by designing the singeing device in the form of a ring which extends around the thread balloon or the cylinder circumscribed by the thread and which is provided with uniformly distributed electrically heated sections. Also in this instance the thread will while being circulated be pulled axially through the ring and will during its rotation at intervals contact heated surface sections of the ring. Inasmuch as the thread does not continuously contact heated sections, heating and cooling zones alternate so that a too strong heating of the thread will be avoided and only the protruding fiber tips will be singed off.

According to another embodiment of the invention, the singeing device may be designed as a rotating wheel with radially directed open flames or electrically heated heating surfaces while said singeing device rotates in a direction opposite to the direction of rotation of the thread. In this instance, the relative velocity between singeing device and thread is a multiple of the thread withdrawal speed so that the thread in a manner customary with yarn singeing machines will be acted upon the singeing device for a short time only and directly whereby it will be assured that the thread will not become unduly hot.

The drive of the singeing device designed as a rotating wheel may according to the present invention be realized by combining the singeing device with a friction wheel and to drive the same by a driving wheel rotating together with the running-ahead roller. The drive will thus directly be derived from the running-ahead roller which is driven anyhow so that a special driving shaft extending through the machine for driving the singeing device will be superfluous.

In order, in this instance, to prevent a too strong heating of the singeing device, especially when an electrically heated singeing device is employed, the singeing device may in conformity with a further development of the invention be designed in the form of a wheel ring rotating about a heating device which conveys its heat only to that section of the wheel ring which faces the thread passing by. Thus, the wheel ring is not heated uniformly throughout but only locally directly within its effective range so that the wheel ring is non-heated and can cool off outside the range of the heating device and outside the section which is within the range of the thread.

The yarn quality can according to the present invention be improved by arranging a thread stripper behind the singeing device. Such thread stripper may be designed in the form of a grooved drum with the groove having a zigzag-shaped form.

In order to prevent the collection of lint and residues of burned fiber tips on the spindle or other machine parts, the present invention suggests the arrangement of the singeing device and/or the thread strippers within a passage housing connected to a suction device for withdrawing and removing dust and burned residues.

In order to prevent that during the stoppage of a spindle the singeing device acts upon the stopped thread for an undue period of time, the singeing device may in conformity with the present invention be so arranged as to be adapted to be moved out of the thread path so that the singeing effect of the singeing device can be interrupted for a short

4

period of time even though the singeing device may continue its operation or requires a certain cooling time if with the stopping of the spindle the singeing device is automatically turned off. This can also be realized in such a way that the singeing device is connected with the spindle brake in such a manner that the singeing device will automatically move out of the thread path in response to the action of the spindle brake. In this way, the stopping of the spindle and the moving of the singeing device out of the thread range form a closed operating step.

Referring now to the drawings in detail, it will be seen from FIGS. 5, 7 and 10 that the thread 1 is withdrawn from the delivery bobbin 2 in an upward direction and is then passed on in downward direction through the hollow shaft 3 of the spindle. Thread 1 will then in a non-illustrated manner leave the thread storage disc in a radial direction and will partially loop around the same and move upwardly in the form of a balloon outside the protective pot 4 but inside the balloon restrainer 5. The thread 1 then passes further by the singeing devices of the various embodiments and moves through thread guiding means to the running-ahead roller 6 while passing over a thread stripper 12, and finally will move onto the winding-up device. More specifically, the thread 1 moves behind the said roller 6 over the traversing thread guide 7 and is wound onto the spool 8 which is driven by a friction roller 9.

Specifically according to FIG. 1, the balloon-shaped rotating thread 1 passes above the spindle by the singeing device comprising a gas burner 11 with flames 10. The flames 10 are directed against the circulating thread 1 which passes the flames 10 in a transverse direction. This short passing of the singeing device will suffice for singeing off protruding fiber tips. After the thread has passed the singeing device, it moves through the pigtail guide 19 and loops once around the thread stripper in the form of a thread stripper roller 12. According to FIG. 4, this thread stripper 12 is designed as a grooved drum the groove bottom of which has a zigzag shape so that the thread 1 for improving the stripping-off operation is deviated several times. The stripping operation will be furthermore improved by the fact that the thread 1 is looped completely once around the thread stripper roller 12 so that the thread 1 after said loop will get into contact with itself.

In order to assure that the thread 1 is guided past the flames 10 of gas burner 11 in a precise manner, a ring 13 shown in dot-dash lines in FIG. 1 may be provided above the spindle. This ring, as shown in FIG. 3, comprises three ring bodies 13a, 13b and 13c by means of which the ring 14 is held on the inner ring side the surface of which is made of wear-resistant material. Such material may, for instance, be ceramic material.

Instead of providing gas burner 11 in which the flames are arranged along a straight line one above the other, also a gas burner 15 according to FIG. 2 may be provided which is arched and comprises flames 10 arranged above and adjacent to each other. Such gas burner may be selected when the circulating and withdrawal speed of thread 1 is of a higher order and thus the thread 1 in spite of being intensively acted upon by the flames 10 will remain within the flame range not longer than is the case with the gas burner 11.

According to the arrangement shown in FIGS. 5 and 6, the singeing device is formed by a singeing ring 17 connected to the gas line 17a. From said singeing ring 17 toward the inside thereof extend uniformly spaced gas flames 10 so that the thread 1 while rotating and moving forwardly in longitudinal direction will with each thread section get into contact only once with a burner flame 10 and only for a short time so that damage to be thread proper cannot occur.

FIG. 6 shows an electrically heated singeing ring 18 the inner surface of which is polygonal so that the thread during its rotation contacts the central sections of the respective polygon only and thus will not be in continuous contact with the heated edge. Consequently, serially heated

ring sections get into contact with thread 1 for singeing off the protruding thread tips.

The thread stripper roller 12a according to FIG. 5 is somewhat different from the roller 12 of FIGS. 1 and 4. As will be seen from FIG. 5, the stripper roller 12a in addition to the zigzag-shaped groove 12a' has additionally a unilaterally arranged annular flange 16 which serves for guiding the thread and along which the thread 1 may, if desired, pass so that the thread stripping device will be further improved. After having been looped around the roller 12a once, the thread 1 comes into contact with itself so that also at this spot an additional stripping operation will occur. The thread stripping roller 12a shown in FIG. 5, is illustrated on a larger scale and in detail in FIG. 9. Said stripper roller 12a is also shown in FIGS. 7 and 8. According to FIG. 7, the singeing device in the form of a ring 7, which may for instance be heated by gas, the thread guiding means 19 therebelow, the thread stripper roller 12a and the running-ahead roller 6 are arranged within a thread passage housing 20 which has the shape of a hood. Housing 20 is connected to a passage 21 communicating with a suction passage 22. In a manner not illustrated in the drawings, the suction passage 22 has connected thereto a suction device so that the lint, dust and burned residues will be withdrawn.

As will be seen from FIGS. 7 and 8, the above mentioned elements may all be connected to the housing 20 so that with a machine all parts associated and cooperating with the singeing device can form a single structural unit.

According to FIG. 10, the singeing device is arranged above the pigtail guide 19. Above said thread guide 19, the thread 1 has imparted thereupon a circulating movement along the contour of a cone the tip of which is determined by the thread guide 19. The base of the upside-down cone is circumscribed by the thread guide 24 which rotates together with the roller or pulley 23. The roller 23 is driven by a friction disc 25 which rotates together with the running-ahead roller 6. The thread 1 passes the thread guide 19 and while rotating moves past the burner 11 with the flames 10 so that the yarn 1 will be singed off. After passing the thread guide 24, the thread 1 is centrally passed through the hollow shaft 26 of roller 23 so that thread 1 will via roller 6 move to the traverse thread guiding means 7 and further onto the winding-up spool 8.

Instead of having the thread 1 following its passage through the thread guide 19 circumscribe a cone, the thread may also circumscribe a cylinder as shown in FIG. 11. According to FIG. 11, the thread guide 27 following the pigtail thread guide 19 is directly supported by the roller 23. The thread guide 27 is furthermore at its angled-off end equipped with a thread guiding eye 27a. Thus, the thread guide 27 is angled off a plurality of times so that the thread 1 which comes from below for instance from the thread guide 19 passes through the eye of thread guide 27 and is radially outwardly deviated and then passes through the thread guiding eye 27a. Thereupon the thread moves vertically upwardly and passes through the eye 24, from there thread 1 is conveyed centrally through the hollow shaft 26 of roller 23 in upward direction. Consequently, thread 1 circumscribes a cylinder and on its way moves past the gas burner 11 with the flames 10 for a short period of time while simultaneously moving on in longitudinal direction.

According to FIG. 12, the singeing device is designed in the form of a wheel 29 which may, for instance, be equipped with a unilaterally arranged friction wheel 28 which latter is driven by the friction wheel 25 of running-ahead roller 6. This friction wheel drive brings about that the singeing device in the form of wheel 29 rotates in a direction opposite to the direction of the thread so that the radially outwardly extending gas flames 10 will pass by the thread 1 at a speed which equals the total withdrawal speed plus the circulating speed of wheel 29. This total speed is therefore so high that only fiber tips will be

singed off, whereas the thread itself will remain undamaged.

Wheel 29 rotates about the gas feeding pipe 30 from which the gas passes into the hollow wheel hub 31 and through the burner openings 32 so that the radially outwardly directed flames 10 are formed. Between a flame pair there are provided radially directed separator plates 33 whereby on one hand the singeing sections of the wheel 29 will be subdivided while on the other hand a support of the thread in spaced relationship to the flame exit openings 32 will be assured. In this way, the thread will pass the flames 10 at a distance at which the flames have the necessary heat. The intermediate plates 33 have a throat 33a so that central guiding of the thread 1 will be assured.

The singeing device designed in conformity with FIG. 13 is similar to that of FIG. 12 but differs therefrom in that an electric heating is provided. The wheel shaft 34 is stationarily arranged and serves for feeding the electric energy. The rotating wheel 38 which is driven by the friction disc 25 of roller 6 through the intervention of the friction disc 28 receives the electric current by means of sliding contacts or collectors 35 from the collecting rings 36 of the wheel shaft 34. In this way, the heating plates 41 which are angled off and arranged all the way around are heated and contacted at the throats 37 by the thread passing by. Inasmuch as the wheel 38 of the thread moving device rotates in the opposite direction, the heating edges of plates 41 will contact thread 1 only for a short period of time but sufficiently long to assure a singeing off of protruding fiber tips.

In distinction to FIG. 12, also the embodiment according to FIG. 14 shows an electrically heated singeing device according to which a wheel ring 39 rotates about a stationary electrically heated heating device 40 which emanates its heat into that section of said ring 39 which respectively is located within the range of the thread 1. This brings about that too strong a heating up of the wheel ring 39 will be avoided because the latter will after passing the heating device 40 move through a cooling zone. Ring 39 corresponding as to shape to that of FIG. 13, in other words, is composed of heating plates 41 which are several times angled off and which are provided with throats or cutouts 37 for receiving the thread.

Wheel ring 39 is rotated by a friction wheel 18 engaged by the friction wheel 25 of roller 6.

Also with this embodiment, the relative speed of thread 1 with regard to the contacting areas with the singeing device amounts to a multiple of the thread withdrawal speed.

In order to avoid an undesired heat radiation or emanation, that section of the singeing device designed in the form of a wheel ring, which does not face the thread 1 is covered by a hood 42.

FIGS. 15 and 16 show a two-for-one twisting spindle of a different construction and with a different path of the thread. The thread 1 coming from the non-illustrated delivery bobbin mounted below the spindle rail 43 passes in the direction of the arrow 44 centrally through the spindle whorl 45 frictionally engaged by the driving belt 46, and after corresponding deviation leaves the thread storage disc 47 in a radial direction. Thread 1 then circumscribes a balloon within the confines of the balloon restrainer 5 which latter by means of a column 48 is connected to the spindle rail 43. Thereupon, the thread 1 moves axially downwardly into the thread guiding tube 49.

While on its balloon-shaped path between the thread storage disc 47 and the thread guiding tube 49, the thread 1 passes by the singeing device 11 with the gas-operated flames 10 so that the thread 1, similar to the embodiment of FIG. 1, is subjected to a singeing action.

After thread 1 has passed the thread guiding tube 49, it is by deviating means 50 conveyed to the traversing roller 51 provided with guiding grooves crossing each other. The thread 1 is partially looped around the roller 51 and is

then wound upon the winding-up spool 52 mounted on a horizontal shaft. The winding-up spool 52 is journaled in said frame 53 which is non-rotatably mounted in the spindle rotor 45, 47 and is driven by roller 51 on which it is upwardly freely displaceably located.

Roller 51 is driven by the spindle rotor 45, 47, the pinion 54 rotating with said rotor, the wheel 54a journaled in said frame 53, and the coaxially arranged pulley 55 which is partially looped around by belt 56. Belt 56 after passing the two deviating pulleys 57 and 58, is looped around the roller 51 and is thus rotated.

This and the subsequent embodiments to be described indicate that a singeing device can be applied to various types of two-for-one twisting spindles in the manner known per se. The twisted thread not only moves in its longitudinal direction but also passes in a transverse direction by said singeing device so that singe conditions are obtained as they prevail with special singeing machines which cause the thread to pass by the singeing device in the longitudinal direction of the thread at an extremely high speed.

According to the two-for-one twisting spindle shown in FIG. 17, the spindle rotor formed by the spindle shaft 61 and rotated in the spindle rail 43 is driven by means of the helical wheels 59 and 60 in such a way that the delivery bobbin pot 62 with the delivery bobbin 2 is freely rotatably suspended but is prevented from turning together with the spindle rotor 61. This is effected in a manner known per se by magnets 63 which are located opposite the ends of the stationary magnet 64.

The thread 1 is in upward direction withdrawn from the delivery bobbin 2, is deviated into the spindle axis, and passes through the spindle rotor which it leaves radially in the plane of the rotor 65 with the thread eye 66. On its way from the thread eye 66 to the thread guiding eye 19, the thread 1 moves in the form of a balloon rotating about the delivery bobbin pot 62 while during a simultaneous movement in the longitudinal direction of the thread, the singeing device 11 or the gas flames 10 thereof are passed by the thread in a transverse direction to be acted upon by the singeing device. Following the thread guiding eye 19, the thread 1 moves around the friction roller 51 against which the winding-up spool 8 is pressed by the thrust of spring 67.

Spindle rail 43, singeing device 11, thread guiding eye 19, friction roller 51 and winding-up reel 8 are all or partially displaceable as to height on a vertical rail 68 of the machine frame.

Also with the embodiment of FIG. 18, the thread is withdrawn upwardly from the delivery bobbin 2 and is deviated into the spindle axis. The delivery bobbin 2 is located within the protective pot 69 with the hood 70 from which the thread 1 passes outwardly through the thread guiding pipe 71. From the end of said pipe 71 the thread in a balloon-shaped manner swings downwardly about the pot 69 and passes radially into the thread storage disc 47 of the spindle rotor. In the interior, thread 1 is axially downwardly deviated and passes through hollow shaft 73 within the whorl 45 and through the spindle rail 43 over the roller 6 and the traversing guide 7 to the winding-up bobbin 8 driven by the friction roller 9.

The balloon restrainer 5 extends around the protective pot 69 as shown in the example of FIG. 1. From its balloon-shaped path, the thread passes from the thread guiding pipe 71 to the thread storage pipe 47 and rotates transverse to the gas fed singeing device 11 so that the thread 1 is subjected to the same singeing effect as has been described in connection with the preceding examples.

With all embodiments of the present invention, it can be provided that the respective singeing device is foldable out of the range of the circulating oscillating thread. This folding over can, of course, be effected by connecting the singeing device with the non-illustrated spindle brake, so that a response of the spindle brake simultaneously brings about a folding over of the singeing device.

It is, of course, to be understood that the present invention is, by no means, limited to the particular embodiments illustrated in the drawings but also comprises any modifications within the scope of the appended claims.

5 What we claim is:

1. In a two-for-one twisting machine: a delivery bobbin for delivering a thread, a winding-up spool adapted to receive and wind up the thread delivered by and passed from said delivery bobbin to said winding-up spool, singeing means arranged along the path of movement of the thread from said delivery bobbin to said winding-up spool for singeing off fiber tips protruding from the thread being delivered by said bobbin and passing by said singeing means, and means for bringing about a relative movement of said singeing means and the respective adjacent thread portion in addition to the advancing movement of said thread from said bobbin to said spool.

2. A twisting machine according to claim 1, in which said thread and said singeing means move relatively transverse to each other.

3. A twisting machine according to claim 1, in which said thread and said singeing means move relative to each other in opposite directions.

4. A twisting machine according to claim 1, which includes means for imparting upon the respective thread section passing by said singeing means a circulatory movement so that the thread moving from said bobbin to said spool at intervals expose successive thread sections to the action of said singeing means.

5. A twisting machine according to claim 1, which includes rotatable thread guiding means to impart upon the respective thread portion passing by said singeing means a rotary movement circumscribing a cylinder.

6. A twisting machine according to claim 1, which includes rotatable thread guiding means to impart upon the respective thread portion passing by said singeing means a rotary movement circumscribing a cone.

7. A twisting machine according to claim 1, which includes: rotatable thread guiding means interposed between said bobbin and said spool for imparting a rotary movement upon the respective thread portion passing by said singeing means, lead roller means interposed between said rotatable thread guiding means and said spool, and friction disc means drivingly interconnecting said lead roller means and said rotatable thread guiding means.

8. A twisting machine according to claim 1, in which said singeing means comprises an annular member surrounding the path of the thread during its movement from said bobbin to said spool and comprising burner means distributed over the inner circumference of said annular member for producing flames within the range of at least a portion of the path of the thread from said bobbin to said spool.

9. A twisting machine according to claim 1, in which said singeing means is formed by an annular member surrounding a portion of the path of the thread from said bobbin to said spool, and heating means associated with said annular member for heating sections thereof, said sections being within the range of the thread passing from said bobbin to said spool through said annular member.

10. A twisting machine according to claim 9, in which said annular member is rotatable, and which includes lead roller means interposed between said annular member and said spool and drivingly connected to said annular member for rotating same.

11. A twisting machine according to claim 1, in which said singeing means is formed by a rotatable member with circumferentially arranged burner means for singeing thread portions passing by said burner means on their way from said spool to said bobbin, and means for rotating said member in a direction opposite to the direction of movement of said thread portions from said bobbin to said spool.

12. A twisting machine according to claim 1, in which

said singeing means is formed by a rotatable member with circumferentially arranged electrically heatable surface sections for singeing thread portions passing by said electrically heatable surface sections on their way from said spool to said bobbin, and means for rotating said member in a direction opposite to the direction of movement of said thread portions from said bobbin to said spool.

13. A twisting machine according to claim 1, in which said singeing means includes an annular rotatable member adapted during its rotation successively to move peripheral portions thereof into the range of thread portions moving from said bobbin to said spool, heating means arranged within said annular member for heating only the respective peripheral portions of said annular member which are within the range of the thread portions moving by said annular member, and driving means rotatably connected to said annular member for rotating the same in a direction opposite to the direction of movement of the thread from said bobbin to said spool.

14. A twisting machine according to claim 1, which includes thread stripper means interposed between said singeing means and said spool for engagement with thread portions passing from said singeing means to said spool.

15. A twisting machine according to claim 14, in which said thread stripper means includes a drum having a zig-zag-shaped annular groove therein for receiving the respective thread portions.

16. A twisting machine according to claim 14, which includes housing means surrounding said thread stripper means and adapted to be connected to suction means.

17. A twisting machine according to claim 1, which

includes housing means surrounding said singeing means and adapted to be connected to a suction device.

18. A twisting machine according to claim 1, which includes means associated with said singeing means for selectively moving the latter out of the range of movement of said thread from said bobbin to said spool.

19. A twisting machine according to claim 1, in which said singeing means is movable out and into the path of movement of said thread from said bobbin to said spool, and which includes a spindle brake, actuating means, operatively interconnecting said spindle brake and said singeing means, and control means operable in response to the actuation of said spindle brake to automatically move said singeing means out of the path of movement of the thread from said bobbin to said spool.

References Cited

UNITED STATES PATENTS

1,777,221	9/1930	Petalot	28—636
2,156,244	4/1939	Mahoney	57—34
2,195,357	3/1940	Carter	28—63
2,870,596	1/1959	Vibber	57—58.83
3,063,124	11/1962	Hilleary et al.	28—62
3,066,471	12/1962	Scragg	57—34.5 XR

FOREIGN PATENTS

773,924 5/1957 Great Britain.

FRANK J. COHEN, *Primary Examiner*.

DONALD E. WATKINS, *Assistant Examiner*.