



(11) **EP 1 898 082 B1**

(12) **EUROPEAN PATENT SPECIFICATION**

(45) Date of publication and mention of the grant of the patent:
18.11.2009 Bulletin 2009/47

(51) Int Cl.:
F02M 51/06^(2006.01) F02M 61/16^(2006.01)

(21) Application number: **06018804.2**

(22) Date of filing: **07.09.2006**

(54) **Valve assembly for an injection valve and injection valve**

Kraftstoffeinspritzventil und Verfahren zu dessen Montage

Soupepe d'injection de combustible et son procédé d'assemblage

(84) Designated Contracting States:
DE FR IT

(43) Date of publication of application:
12.03.2008 Bulletin 2008/11

(73) Proprietor: **Continental Automotive GmbH**
30165 Hannover (DE)

(72) Inventors:
• **Biasci, Enio**
56010 Campo
Pisa (IT)
• **Grandi, Mauro**
57100 Livorno (IT)

(56) References cited:
US-A- 5 201 341

EP 1 898 082 B1

Note: Within nine months of the publication of the mention of the grant of the European patent in the European Patent Bulletin, any person may give notice to the European Patent Office of opposition to that patent, in accordance with the Implementing Regulations. Notice of opposition shall not be deemed to have been filed until the opposition fee has been paid. (Art. 99(1) European Patent Convention).

Description

[0001] The invention relates to a valve assembly for an injection valve and an injection valve.

[0002] Injection valves are in wide spread use, in particular for internal combustion engines where they may be arranged in order to dose the fluid into an intake manifold of the internal combustion engine or directly into the combustion chamber of a cylinder of the internal combustion engine.

[0003] Injection valves are manufactured in various forms in order to satisfy the various needs for the various combustion engines. Therefore, for example, their length, their diameter and also various elements of the injection valve being responsible for the way the fluid is dosed may vary in a wide range. In addition to that, injection valves may accommodate an actuator for actuating a needle of the injection valve, which may, for example, be an electromagnetic actuator or piezo electric actuator.

[0004] In order to enhance the combustion process in view of the creation of unwanted emissions, the respective injection valve may be suited to dose fluids under very high pressures. The pressures may be in case of a gasoline engine, for example, in the range of up to 200 bar and in the case of diesel engines in the range of up to 2000 bar.

[0005] US 5,201,341 discloses a fluid flow control valve with a valve assembly. The valve assembly includes a central longitudinal axis and comprises a valve body shell having a recess forming an inner surface of the valve body shell, a valve body being arranged in the recess of the valve body shell, the valve body comprising an outer surface with a mounting contact area facing the inner contact surface of the valve body shell and extending in axial direction, the valve body comprising a cavity with a fluid inlet portion and a fluid outlet portion, a valve needle being axially movable in the cavity, the valve needle preventing a fluid flow through the fluid outlet portion in a closing position and releasing the fluid flow through the fluid outlet portion in further positions. The valve assembly further comprises a sealing element which is arranged coaxially between the valve body and the valve body shell.

[0006] The object of the invention is to create a valve assembly which is simply to be manufactured and which facilitates a reliable and precise function.

[0007] These objects are achieved by the features of the independent claim. Advantageous embodiments of the invention are given in the sub-claims.

[0008] According to a first aspect the invention is distinguished by a valve assembly for an injection valve including a central longitudinal axis, comprising a valve body shell having a recess forming an inner surface of the valve body shell, a valve body being arranged in the recess of the valve body shell, the valve body comprising an outer surface with a mounting contact area facing the inner contact surface of the valve body shell and extend-

ing in axial direction, the valve body comprising a cavity with a fluid inlet portion and a fluid outlet portion, a valve needle being axially movable in the cavity, the valve needle preventing a fluid flow through the fluid outlet portion in a closing position and releasing the fluid flow through the fluid outlet portion in further positions. The valve assembly further comprises a sealing element being arranged coaxially between the valve body and the valve body shell. The sealing element is arranged at an end of the mounting contact area, the end facing away from the fluid outlet portion, the sealing element thereby sealingly coupling the valve body to the valve body shell.

[0009] The mounting contact area is the part of the outer surface of the valve body which can be in contact with the inner surface of the valve body shell during the operation of the injection valve as well as during the mounting of the injection valve. The mounting contact area can be formed in one part but it may also be interrupted by recesses and grooves and be formed in several parts.

[0010] During the assembly process of the injection valve sections of the recess of the valve body shell may be charged with particles generated by a contact between the mounting contact area of the valve body and the inner surface of the valve body shell. The sealing element between the valve body and the valve body shell can advantageously prevent a fluid flow between sections of the recess charged with particles and sections of the recess not charged with particles. As the sealing element is arranged at an end of the mounting contact area, which is facing away from the fluid outlet portion, the section of the recess extending from the sealing element in axial direction away from the fluid outlet portion can be prevented from being charged with particles during the assembly process. Consequently, if one of the sections of the recess not charged with particles is hydraulically coupled to the cavity with the fluid outlet portion, even in the case of a fluid flow between this section of the recess not charged with particles and the fluid outlet portion, it is possible to protect the fluid outlet portion from particles generated during the assembly process of the injection valve.

[0011] Preferably the valve body has a groove facing the valve body shell and the sealing element is arranged in the groove. This has the advantage that a fixed arrangement of the sealing element in the valve body is possible.

[0012] In an advantageous embodiment the sealing element comprises a material being of plastics. This makes it possible to obtain good sealing properties of the sealing element and to avoid the appearance of particles in the cavity of the valve body with the fluid outlet portion generated during the assembly process

[0013] In a further advantageous embodiment the sealing element comprising a material being a rubber. Rubber is a plastic with a low elasticity module and allows a low-cost solution. Preferably, the sealing element consists of viton (Registered Trade Mark). Viton is a synthetic

rubber and a fluoropolymer elastomer which has a high stability against aggressive chemicals like fuels.

[0014] According to a second aspect the invention is distinguished by a fuel injector comprising a valve assembly with a sealing element.

[0015] Exemplary embodiments of the invention are explained in the following with the aid of schematic drawings. These are as follows:

Figure 1, an injection valve with a valve assembly in a longitudinal section view,

Figure 2, a part of the valve assembly of the injection valve according to figure 1 in a longitudinal section view, and

Figure 3, an enlarged view of section III of figure in a longitudinal section view.

[0016] Elements of the same design and function that appear in different illustrations are identified by the same reference character.

[0017] An injection valve 62 (figure 1), that is in particular suitable for dosing fuel to an internal combustion engine, comprises an inlet tube 2, a housing 6 and a valve assembly 60.

[0018] The valve assembly 60 comprises a valve body 4 with a cavity 8, which takes in a valve needle 10 comprising an armature 12. In the inlet tube 2 a recess 16 is provided which further extends to a recess 18 of the armature 12. A spring 14 is arranged in the recess 16 of the inlet tube 2 and/or the recess 18 of the armature 12. Preferably, it rests on a spring seat being formed by an anti-bounce disc 20. By this the spring 14 is mechanically coupled to the needle 10. An adjusting tube 22 is provided in the recess 16 of the inlet tube 2. The adjusting tube 22 forms a further seat for the spring 14 and is axially movable during the mounting process of the injection valve 62 in order to preload the spring 14 in a desired way.

[0019] In a closing position of the needle 10 it sealingly rests on a seat plate 26 by this preventing a fluid flow through at least one injection nozzle 24. The injection nozzle 24 may be, for example, an injection hole. However, it may also be of some other type suitable for dosing fluid. The seat plate 26 may be made in one part with the valve body 4 or a separate part from the valve body 4. In addition to that a lower guide 28 for guiding the needle 10 is provided. Additionally, a swirl disc 30 is provided.

[0020] The injection valve 62 is provided with an actuator unit that comprises preferably an electromagnetic actuator with a coil 36, which is preferably overmolded. A valve body shell 38, the armature 12 and the inlet tube 2 are forming an electromagnetic circuit. The actuator unit may, however, also comprise another type of actuator, which is known to a person skilled in the art for that purpose. Such an actuator may be, for example, a piezoelectric actuator.

[0021] A fluid inlet portion 42 is provided in the valve

body 4 which communicates with a fluid outlet portion 44 which is a part of the cavity 8 near the seat plate 26.

[0022] The valve body shell 38 has a recess 40 with two sections, a chamber 40a and a gap 40b (figure 3).

5 The gap 40b is arranged in radial direction between the valve body shell 38 and the valve body 4. The chamber 40a is extending from the gap 40b in axial direction away from the fluid outlet portion 44 and is hydraulically coupled to the recess 18 of the armature 12 of the valve needle 10 by a channel 48. The recess 18 of the armature 12 of the valve needle 10 is hydraulically coupled to the cavity 8 by an opening 45 in the valve needle 10.

[0023] A sealing element 46 is arranged coaxially between the valve body 4 and the valve body shell 38 thereby hydraulically separating the chamber 40a from the gap 40b. The sealing element is sealingly coupling the valve body 4 to the valve body shell 38. Consequently, a fluid flow from the gap 40b to the chamber 40a and vice versa is prevented.

20 **[0024]** The valve body 4 has a groove 50 facing the valve body shell 38. The groove 50 is designed to receive the sealing element 46, thereby enabling the sealing element 46 to be fixed in the valve body 4.

[0025] The sealing element 46 comprises a material which is a plastics. Plastics can be a cost-saving material and it is possible to obtain good sealing properties of the sealing element 46. In particular, the sealing element 46 comprises a material which is a rubber. A rubber is a plastics which has a low elasticity module. Therefore, a good sealing between the valve body shell 38 and the valve body 4 is possible. Furthermore, the use of rubber allows a low-cost solution for the sealing element 46. Preferably, the sealing element comprises a material which consists of viton (registered trademark). Viton has the advantage that it has a particularly high stability against aggressive fluids like fuels.

[0026] The recess 40 of the valve body shell 38 forms an inner surface 54 of the valve body shell 38. The valve body 4 has an outer surface 52 with a mounting contact area 52a. The mounting contact area 52a is facing the inner contact surface 54 of the valve body shell 38 and extends in an axial direction to end in a first axial end 56 facing away from the fluid outlet portion 44.

[0027] The valve body 4 further comprises a bag 58 which is arranged near an second axial end 57 of the mounting contact area 52a of the valve body 4, the second axial end 57 facing the fluid outlet portion 44.

[0028] In the following, the function of the injection valve 10 is described:

45 **[0029]** The fluid flows through the inlet tube 2 and the adjusting tube 22 to the recess 18 of the armature 12. Through the opening 45 in the valve needle 10 the fluid flows to the cavity 8 of the valve body 4 and further on to the fluid outlet portion 44.

55 **[0030]** The axial position of the valve needle 10, which determines whether the fluid outlet portion 44 is opened or closed for a fluid flow, depends on the force balance between the spring and the forces applied to the valve

needle 10 by the actuator unit with the coil 36.

[0031] In the closing position of the valve needle 10 the valve needle 10 sealingly rests on the seat plate 26 and consequently prevents a fluid flow through the fluid outlet portion 44 and the injection nozzle 24.

[0032] In the case that the coil 36 gets energized, a force is affected on the valve needle 10. The valve needle 10 is able to move in axial direction out of the closing position.

[0033] If the valve needle 10 is moving upward from its closing to an opening position the volume of the chamber 40a increases. Fluid can flow from the recess 18 of the armature 12 of the valve needle 10 through the channel 48 to the chamber 40a. Due to the properties of the chamber 40a and the channel 48 the chamber 40a in combination with the channel 48 can have a dampening effect on the movement of the valve needle 10.

[0034] Outside the closing position of the valve needle 10 a fluid flow through the injection nozzle 24 is enabled.

[0035] If the valve needle 10 is moving downward from an opening position to the closing position the volume of the chamber 40a decreases and fluid can flow from the chamber 40a through the channel 48 to the recess 18 of the armature 12 of the valve needle 10. By this, a dampening effect of the movement of the valve needle 10 can occur as well depending on the properties of the chamber 40a and the channel 48.

[0036] In the following, a part of the assembly process of the injection valve 62 will be described:

[0037] During the assembly process the valve assembly part of figure 2 with the valve body 4 is inserted into the recess 40 of the valve body shell 38. This is achieved by a precise press-fit operation. The tolerances of the valve body 4 and the valve body shell 38 are very small to guarantee a tight positioning of the valve body 4 in the valve body shell 38. Due to these small tolerances particles can be set free during the press-fit operation due to the axial movement of the mounting contact area 52a of the valve body 4 relative to the inner contact surface 54 of the valve body shell 38.

[0038] As the sealing element 46 is arranged coaxially between the valve body 4 and the valve body shell 38 at the first axial end 56 of the mounting contact area 52a the chamber 40a can be prevented from being charged with particles. On the other hand, it is possible that the gap 40b, which extends from the sealing element 46 in an axial direction towards the fluid outlet portion 44, is charged with particles. The particles in the gap 40b are prevented from being transported into the chamber 40a and can preferably be collected in the bag 58 of the valve body 4. After the press-fit operation between the valve body 4 and the valve body shell 38 the valve body 8 is fixedly coupled to the valve body shell 38, the coupling carried out preferably by welding.

[0039] As a fluid flow from the gap 40b to the chamber 40a is prevented by the sealing element 46 particles can be prevented from being transported from the gap 40b to the chamber 40a by the fluid flow during the operation

of the injection valve 62 as described above. Therefore, a transport of particles to the fluid outlet portion 44 can be prevented in the case of any fluid flow between the chamber 40a, the recess 18 of the armature 12 of the valve needle 10, the cavity 8 of the valve body 4 and the fluid outlet portion 44.

Claims

1. Valve assembly (60) for an injection valve (62) including a central longitudinal axis (L), comprising

- a valve body shell (38) having a recess (40) forming an inner surface (54) of the valve body shell (38),

- a valve body (4) being arranged in the recess (40) of the valve body shell (38), the valve body (4) comprising an outer surface (52) with a mounting contact area (52a) facing the inner contact surface (54) of the valve body shell (38) and extending in axial direction, the valve body (4) comprising a cavity (8) with a fluid inlet portion (42) and a fluid outlet portion (44),

- a valve needle (10) being axially movable in the cavity (8), the valve needle (10) preventing a fluid flow through the fluid outlet portion (44) in a closing position and releasing the fluid flow through the fluid outlet portion (44) in further positions, and

- a sealing element (46) being arranged coaxially between the valve body (4) and the valve body shell (38),

characterized in that the sealing element (46) is arranged at an axial end (56) of the mounting contact area (52a), the axial end (56) facing away from the fluid outlet portion (44), the sealing element (46) thereby sealingly coupling the valve body (4) to the valve body shell (38).

2. Valve assembly (60) according to claim 1, with the valve body (4) having a groove (50) facing the valve body shell (38) and the sealing element (46) being arranged in the groove (50).

3. Valve assembly (60) according to one of the preceding claims, with the sealing element (46) comprising a material being of plastics.

4. Valve assembly (60) according to one of the preceding claims, with the sealing element (46) comprising a material being of rubber.

5. Injection valve (62) with a valve assembly (60) according to one of the preceding claims.

Patentansprüche

1. Ventilanordnung (60) für ein Einspritzventil (62), umfassend eine zentrale Längsachse (L), umfassend

- ein Ventilkörpergehäuse (38), das eine Aussparung (40) aufweist, die eine Innenfläche (54) des Ventilkörpergehäuses (38) bildet,
- einen Ventilkörper (4), der in der Aussparung (40) des Ventilkörpergehäuses (38) angeordnet ist, wobei der Ventilkörper (4) eine Außenfläche (52) mit einer Montagekontaktfläche (52a) umfasst, die der inneren Kontaktfläche (54) des Ventilkörpergehäuses (38) zugewandt ist und sich in axialer Richtung erstreckt, wobei der Ventilkörper (4) einen Hohlraum (8) mit einem Fluid-Einlassbereich (42) und einem Fluid-Auslassbereich (44) umfasst,
- eine Ventalnadel (10), die axial in dem Hohlraum (8) bewegbar ist, wobei die Ventalnadel (10) einen Fluidfluss durch den Fluid-Auslassbereich (44) in einer Schließposition verhindert und den Fluidfluss durch den Fluid-Auslassbereich (44) in weiteren Positionen freigibt, und
- ein Dichtelement (46), das koaxial zwischen dem Ventilkörper(4) und dem Ventilkörpergehäuse (38) angeordnet ist,

dadurch gekennzeichnet, dass das Dichtelement (46) an einem axialen Ende (56) der Montagekontaktfläche (52a) angeordnet ist, wobei das axiale Ende (56) von dem Fluid-Auslassbereich (44) abgewandt ist, wodurch das Dichtelement (46) den Ventilkörper (4) mit dem Ventilkörpergehäuse (38) dichtend koppelt.

2. Ventilanordnung (60) nach Anspruch 1, wobei der Ventilkörper (4) eine Nut (50) aufweist, die dem Ventilkörpergehäuse (38) zugewandt ist, und das Dichtelement (46) in der Nut (50) angeordnet ist.
3. Ventilanordnung (60) nach einem der vorhergehenden Ansprüche, wobei das Dichtelement (46) einen Werkstoff umfasst, der aus Kunststoffen besteht.
4. Ventilanordnung (60) nach einem der vorhergehenden Ansprüche, wobei das Dichtelement (46) einen Werkstoff umfasst, der aus Gummi besteht.
5. Einspritzventil (62) mit einer Ventilanordnung (60) nach einem der vorhergehenden Ansprüche.

Revendications

1. Ensemble de soupape (60) pour une soupape d'injection (62) ayant un axe central longitudinal (L),

comprenant

- une coque de corps de soupape (38) ayant un évidement (40) formant une surface interne (54) de la coque de corps de soupape (38),
- un corps de soupape (4) agencé dans l'évidement (40) de la coque de corps de soupape (38), le corps de soupape (4) comprenant une surface externe (52) présentant une zone de contact de montage (52a) faisant face à la surface de contact interne (54) de la coque de corps de soupape (38) et s'étendant dans une direction axiale, le corps de soupape (4) comprenant une cavité (8) ayant une partie d'entrée de fluide (42) et une partie de sortie de fluide (44),
- un pointeau de soupape (10) étant déplaçable axialement dans la cavité (8), le pointeau de soupape (10) empêchant un écoulement de fluide à travers la partie de sortie de fluide (44) en position de fermeture et libérant l'écoulement de fluide à travers la partie de sortie de fluide (44) dans d'autres positions, et
- un élément d'étanchéité (46) agencé de façon coaxiale entre le corps de soupape (4) et la coque de corps de soupape (38),

caractérisé en ce que l'élément d'étanchéité (46) est agencé à l'emplacement d'une extrémité axiale (56) de la zone de contact de montage (52a), l'extrémité axiale (56) étant tournée à l'opposé de la partie de sortie de fluide (44), l'élément d'étanchéité (46) couplant par conséquent de manière étanche le corps de soupape (4) à la coque de corps de soupape (38).

2. Ensemble de soupape (60) selon la revendication 1, le corps de soupape (4) présentant une rainure (50) faisant face à la coque de corps de soupape (38) et l'élément d'étanchéité (46) étant agencé dans la rainure (50).
3. Ensemble de soupape (60) selon l'une des revendications précédentes, l'élément d'étanchéité (46) comprenant un matériau constitué de plastique.
4. Ensemble de soupape (60) selon l'une des revendications précédentes, l'élément d'étanchéité (46) comprenant un matériau constitué de caoutchouc.
5. Soupape d'injection (62) ayant un ensemble de soupape (60) selon l'une des revendications précédentes.

FIG 1

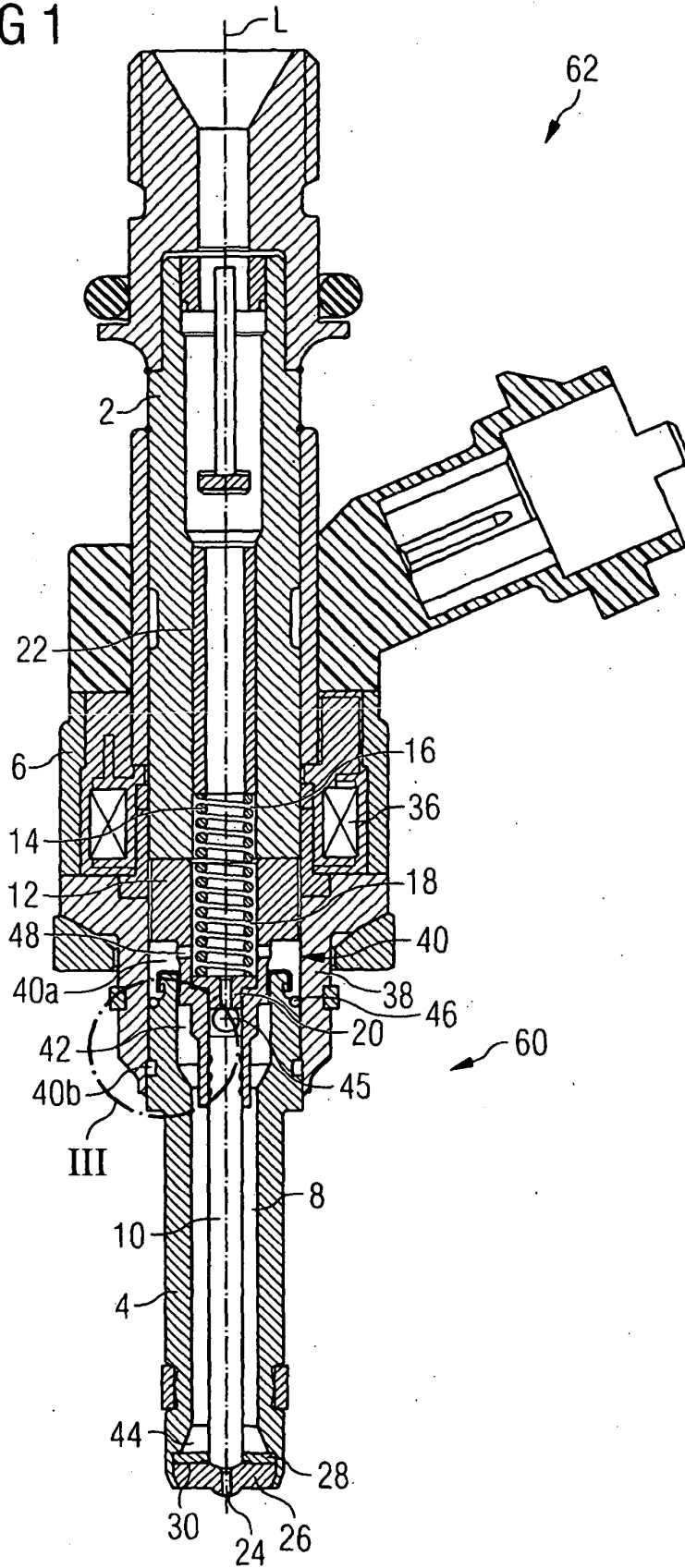

FIG 2

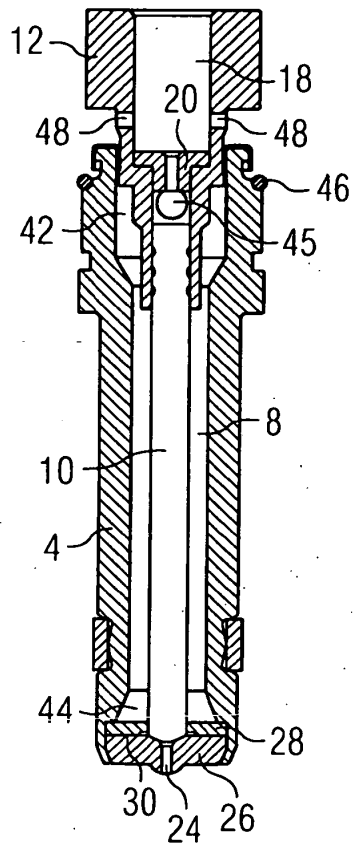
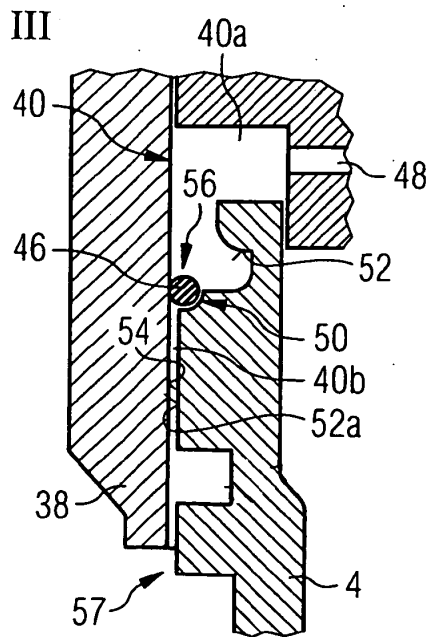

FIG 3



REFERENCES CITED IN THE DESCRIPTION

This list of references cited by the applicant is for the reader's convenience only. It does not form part of the European patent document. Even though great care has been taken in compiling the references, errors or omissions cannot be excluded and the EPO disclaims all liability in this regard.

Patent documents cited in the description

- US 5201341 A [0005]