

Aug. 5, 1947.

L. A. MEACHAM

2,425,112

PLATEN SCALE FOR TYPEWRITERS

Filed Aug. 16, 1946

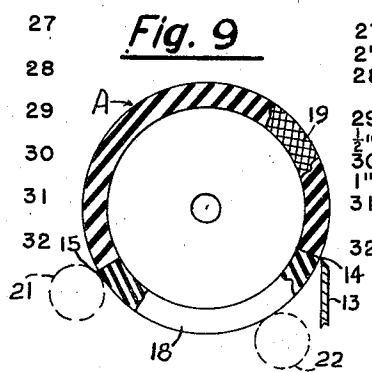
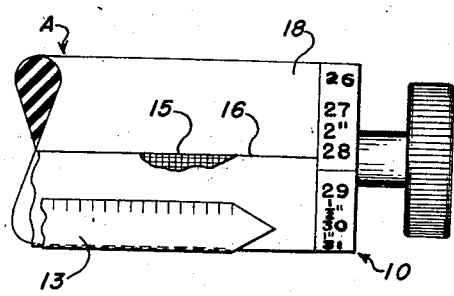
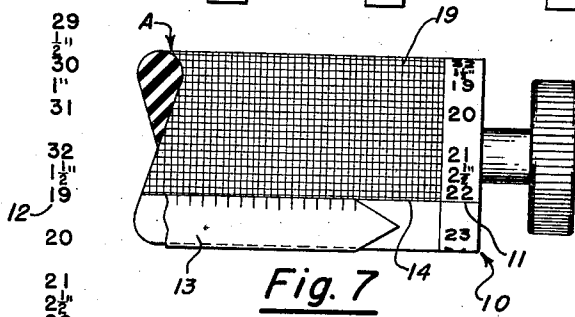
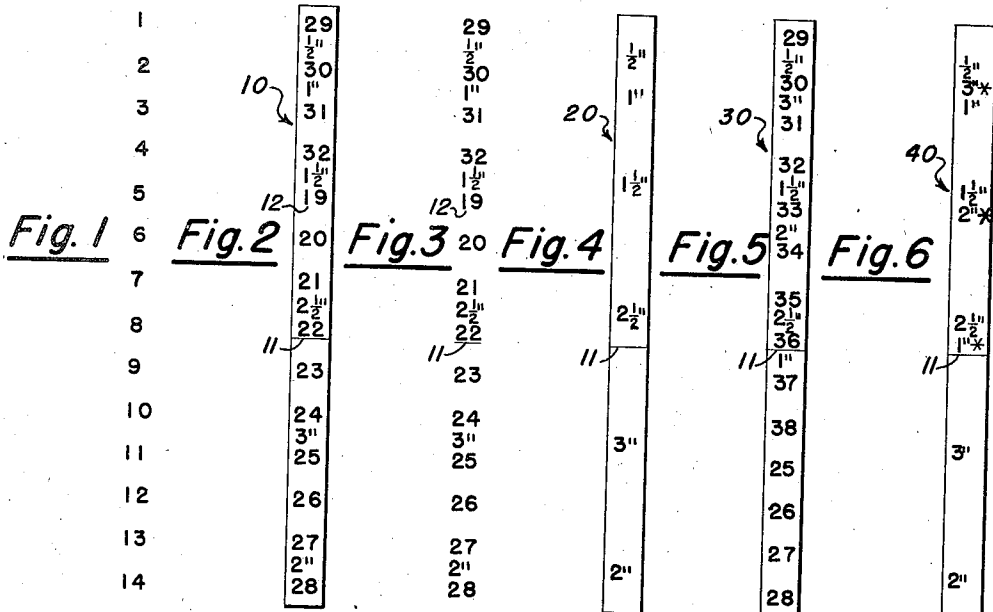

Inventor
 Lotta Allen Meacham
Richard K. Hulley
 Attorney

UNITED STATES PATENT OFFICE

2,425,112

PLATEN SCALE FOR TYPEWRITERS

Lotta Allen Meacham, Laguna Beach, Calif.

Application August 16, 1946, Serial No. 691,104

6 Claims. (Cl. 197—189)

1

The invention relates to improvements in platen scales for typewriters or like machines.

An object of this invention is to provide means by which an operator can at a glance fix top and bottom margins on work-sheets at any points desired whereby to write pages without writing too near the tops and bottoms, to keep top and bottom margins of consecutive pages uniform, to put the same number of lines on consecutive pages, to estimate designated spaces for footnotes and to secure other valuable advantages.

Another object of the invention is to provide a construction whereby the work sheet may be introduced into the machine either by releasing the feed rolls and slipping the work sheet into position or by spacing the work sheet into position by means of the feed rolls so that the work sheet may be readily and accurately positioned relative to the platen scales.

Still another object is to provide a novel platen construction which coacts with the platen scales to the further extent of supplying a warning signal readily visible to the operator that the end of the work sheet is approaching so that the operator may then direct his careful attention to the platen scale in use.

A further object is to provide a scale device adapted for use with all typewriters or like machines upon which a definite number of single spaced and double spaced lines to the inch are written, with platens of different circumferences and typewriting paper or other work sheets of various lengths in addition to the standard 11" and 13" lengths.

Other objects and advantages will be apparent from the accompanying drawings wherein a preferred embodiment of the principles of the invention has been selected for exemplification.

In the drawings:

Figure 1 is a diagrammatic illustration representing the double-spaced lines that can be written on a work sheet 11" in length;

Figure 2 is a front elevational view of a platen scale adapted for use with work sheets 11" in length;

Figure 3 is a diagrammatic illustration of the platen scale of Figure 2 as it revolves with a standard platen four and three-quarter inches in circumference;

Figure 4 is a side elevational view of a platen scale similar to that of Figure 2 but modified to contain only dimensional symbols;

Figure 5 is a side elevational view of a platen scale similar to that of Figure 2 but modified for use with work sheets 13" in length;

2

Figure 6 is a side elevational view of a further modified form of platen scale made up of dimensional symbols and adapted for use with work sheet either 11" or 13" in length;

Figure 7 is a fragmentary side elevational view of the platen of a typewriter composed of longitudinal sections of contrasting colors and having the scale of Figure 2 attached and positioned for spacing the work sheet into operative position in the machine;

Figure 8 is a view similar to Figure 7 but showing the platen and work sheet in position for initial use of the scale; and

Figure 9 is a transverse view partly in section of Figure 7 showing the feed rolls in dotted lines and illustrating the peripheral extent of the contrasting color sections of the platen.

The platen scales herein illustrated and described are adapted for typewriters upon which three double spaced and six single spaced lines to the inch are written. Such platen scales contain numerical indices relating to lines on the work sheet and space indicators, or fractional and full-number dimensional symbols relating to top and bottom margins on the work sheet. These two sets of characters supplement each other, but the sets can be divided, if desired, and only one set used as a platen scale. The preferred platen scale is to be placed around one end of the platen of a typewriter, either during the manufacture of the platen, or printed on a band of suitable material and fastened around one end of the platen at any time, with numerical indices and dimensional symbols in the platen scale in alignment with the writing lines of the work sheet, which writing lines are spaced by the ratchet that governs the forward movement of the platen.

Referring more particularly to the drawings wherein like numerals refer to like parts, Figure 1 represents line numbers, the 32 double spaced lines that can be written on a work sheet 11" in length. It is presented only for the purpose of comparison with the remaining figures.

Figure 2 shows a strip 10 which represents a flat platen scale for paper 11" in length. It is four and three-fourths inches long, representing one complete revolution of the platen. Strip 10 is made up of the single indicium, or horizontal bar, numerical indices and dimensional symbols, spaced according to the spacing of the forward movement of the platen. The numerical indices refer to lines on the work sheet. The dimensional symbols designate approximate spaces for top and bottom margins. The fractional symbols refer to top margins. The full-number symbols

3

refer to bottom margins. The measurements for these dimensional symbols vary a small fraction of an inch from accurate measurements in order to conform to the spacing of the typewriter. This makes the dimensional symbols approximate, but uniform for each length of paper and accurate enough for all marginal uses. The first character in each platen scale should be signaled by being printed in red to mark the beginning of the platen scale when it is placed in a circle around the platen. The single indicium, or horizontal bar, designated by 11, when placed in alignment with the aligning scale, or writing line, of the machine, positions the platen for spacing the work sheet into the machine. It should also be signaled by being printed in red.

Figure 3 represents the repetition of platen scale 10 shown in Figure 2, as it revolves with the platen while the work sheet is written. By comparing Figure 3 with Figure 1 and Figure 2, it will be evident: that the platen scale, Figure 2, provides line-indicators for the entire length of the work sheet; that during the writing of a page of 32 lines, the platen makes two complete revolutions and, in addition, the space for four double spaced lines of a third revolution; that during the second revolution of the platen, soon after passing the middle of the work sheet, at line 19, the index 19 in the platen scale, designated at 12, corresponds at the aligning scale, or writing line, of the machine to the number of the line being written on the work sheet, and the numerical indices, or line numbers in the platen scale, from that line to and including line 32, correspond at the aligning scale to the numbers of the lines being written on the work sheet, which makes line numbers available at a glance from line 19 to the bottom of the page and; that the fractional symbols designate top margins up to $2\frac{1}{2}$ " while the full-number symbols designate bottom margins up to 3".

Figure 4 shows a modified scale strip 20 having dimensional symbols relating to top and bottom margins on the work sheet. Scale 20 is identical with scale 10 but with the numerical indices omitted and may be preferred when the operator is concerned only with the general dimensions of the work sheet margins. Like the form shown in Figure 2, strip 20 has the single indicium or horizontal bar 11. But, unlike the form shown in Figure 2, the initial character in Figure 4 is positioned one triple typewriter space, or three single typewriter spaces from the top of the work sheet.

Figure 5 shows as strip 30 a companion platen scale to that of Figure 2. Scale 30 is for paper 13" in length, on which 38 double-spaced lines can be written. Scale 30 is repeated during the writing of a work sheet in the same manner as the scale 10 is repeated in Figure 3. But, in scale 30, the lines on the work sheet and the line numbers on the platen scale begin correlating at line 29. Scale 30 can be divided, as scale 10 is divided, to make a platen scale similar to the scale 20 containing only dimensional symbols. Scale 30 can be put around one end of a platen opposite scale 10, or a platen scale similar to 30 but made up of dimensional symbols only can be put around one end of a platen opposite scale 20, if desired. Thus the set of platen scales, 10 and 30 or the set of platen scales 20 and a platen scale similar to 30 but made up of dimensional symbols only would make a choice of either set of platen scales for papers 11" and 13" in length, which are standard work sheets in

4

typewriting. Either set of such platen scales when properly placed around the ends of a platen of the circumference for which the platen scales are made will be adequate indicators for top and bottom margins for any writing that can be done on papers of those lengths, and, by individual methods, operators from them can establish top and bottom margins for papers of other lengths.

Figure 6 shows as strip 40 a single platen scale for work sheets both 11" and 13" in length. This platen scale is made up of dimensional symbols indicating top margins up to $2\frac{1}{2}$ " and bottom margins up to 3" for both lengths of work sheets. In platen scale 40 the top margins, $\frac{1}{2}$ ", $1\frac{1}{2}$ ", $2\frac{1}{2}$ ", are the same for both lengths of paper. The bottom margins, 1", 2", 3", are for paper 11" in length. The bottom margins, 1"*, 2"*, 3"*, are for paper 13" in length. Scale 40 is similar to scale 20 for paper 11" in length, but has added the dimensional symbols for bottom margins of scale 30 for paper 13" in length, which bottom margin indicators for paper 13" in length are marked with an asterisk to distinguish them from bottom margin indicators for paper 11" in length. Like the initial character in Figure 4, the initial character in Figure 6, strip 40, is positioned one triple typewriter space, or three single typewriter spaces from the top of the work sheet. Because of conflict for space in this single platen scale 40, the bottom margin indicators for paper 13" in length are moved one single typewriter space above their positions on scale 30, which, however, is not sufficient displacement to cause confusion. As for other measurements represented by dimensional symbols, the measurements for these dimensional symbols vary a small fraction of an inch from accurate measurements in order to conform to the spacing of the typewriter. This also makes these dimensional symbols approximate, but uniform for each length of paper and as accurate as they can be made under the circumstances.

Figure 7 shows an end fragment of the platen of a typewriter indicated in its entirety by A with a platen scale 10, as it appears around the end of the platen. It is understood that any other scale may be employed instead of member 10 which is selected merely for exemplification. Aligning scale 13 marks the writing line of the machine. The horizontal bar, or single indicium, designated by 11, is shown in the correct position for spacing the work sheet into the machine.

Platen A is of novel construction and arrangement and is composed of longitudinal sections 18 and 19 of contrasting colors such as black and white, as shown. The junctures of the sections 18 and 19 extend in straight lines axially of the platen to form opposed lines of demarcation 14 and 15. The contrasting colors are so distributed lengthwise of the platen that the line of demarcation 14 is always in alignment with the single indicium, or horizontal bar 11, in the platen scale 10, and, while the black portion 19 of the platen is uppermost, the single indicium, or horizontal bar 11 and the line of demarcation 14 between the two colors, when in alignment with the aligning scale, or writing line of the typewriter, will position the platen for spacing the work sheet into the machine; at the same time, the opposed line of demarcation 15 will be in alignment with the upper edge of the work sheet as it correlates with the engagement of the platen and the rearward feed rolls 21 when the work sheet is placed at the line from which it is to be spaced into the

5

machine as will be apparent from Figure 9. Then, when the platen is rotated forward and the work sheet is spaced to the first double spaced line that can be written on the work sheet, the white portion 18 of the platen will be uppermost. In this position the alignment between the line of demarcation 15 and the upper edge of the work sheet is the starting point from which top margins on the work sheet can be computed, which computations are registered in the platen scale 19 encircling an end of the platen. In addition, when it is desirable to release the feed rolls 21 and 22 and slip the work sheet to position, the upper edge of the work sheet may be aligned with the line of demarcation 15 at any convenient place on the platen, which alignment is the same starting point from which top margins can be computed as the alignment for the computations when the work sheet is spaced into the typewriter.

In Figure 8 the white portion 18 of the platen A is uppermost and the line of demarcation 15 is in alignment with the upper edge 16 of the work sheet when the work sheet is spaced to position. This common alignment is the starting point from which top margins on the work sheet are computed, which computations, registered on platen scales, designate accurate and easily-used indicators for any top margins desired. In Figure 8 the initial character in the platen scale which marks the first double spaced line that can be written on the work sheet is the numeral 29. The common alignment 15 and 16 designates the starting point from which top margins on the work sheet can be computed. The computations for these top margins are registered in the platen scale by fractional dimensional symbols, or by arbitrarily selected numerical indices, which make it possible for operators at a glance to set any top margins desired. In addition, this accurate beginning of the work sheet makes line numbers available soon after passing the middle of the page and makes it possible for an operator at a glance to set bottom margins by full-number dimensional symbols in the platen scale. With this combination of marginal indicators, the operator has a wide choice for both top and bottom margins and any margins can be changed at will without complications or the adjustment of mechanisms.

Aside from providing the opposed paper positioning guide lines 14 and 15 described above, the novel multi-colored platen of the present invention provides a warning signal readily visible to the operator to denote approach of the end of the work sheet as the platen is rotated so that the operator's attention may be directed more closely to the platen scale. The longitudinal sections 18 and 19 of the contrasting colors, portions of which remain visible to the operator while the machine is being used, provide such a signal when the visible part of the rotating platen changes from one color to another. In addition, the varied colors correlated as they are with the platen scale facilitate positioning of the platen for accurate introduction of the work sheet. If desired, the contrasting-color principle may also be employed in the scales which, instead of being a strip of white or other solid color, may be divided into different colors in the same circumferential manner as the platen described herein and used in conjunction with the platen A or with any conventional type of platen. Alternatively, the background of the scale strip may be of a single color and the indicia of contrasting colors or, multi-colored indicia may be combined with

6

a multi-colored strip. For general purposes however, the combined platen and scale specifically shown in Figures 7 and 8 is the preferable form of the present invention.

In platen scales based on the principles of construction and operation herein, there are a few variations, which, however, are so slight that they will cause no confusion. For example, platen scales for use on typewriters of different manufacture that vary in the space between the rearward feed rolls 21 and the position of the first double spaced writing line may require a slightly different positioning of the single indicium, or horizontal bar 11. Platen scales with fractions of inches in the measurements of their circumferences, which make it impossible for an exact number of lines to correlate with one complete revolution of the platen, may have characters in the platen scales that do not correlate to a small fraction of an inch with the aligning scale and the line being written after one complete revolution of the platen and the added thickness of papers for carbon copies may make a small discrepancy between the lines being written and the characters in the platen scales. Also, the peripheral extent of the contrasting or distinctive color portions of the platen will vary somewhat according to the make of the typewriter. For most purposes, however, the peripheral extent of approximately one-third and two-thirds as shown in Figure 9 will be satisfactory. Specifically, in a platen four and three-fourths inches in circumference, the relative peripheral extent will be two inches and two and three-fourths inches.

In the operation of the device herein illustrated and described, it is assumed that the platen A has been surfaced with a composition of two colors 18 and 19, for example, black and white, and divided lengthwise of the platen as hereinbefore described. It is also assumed that a platen scale such as 10 has been placed around one end of the platen with the single indicium, or horizontal bar 11, at the aligning scale, or writing line of the machine. It is further assumed that the related platen scale has been tested for the position of the single indicium, or horizontal bar 11, for the particular machine in use.

For the introduction of the work sheet into the typewriter the operator has the choice of releasing the feed rolls 21 and 22 and slipping the work sheet to position, or of spacing the work sheet to position.

For slipping the work sheet to position, the platen is rotated forward until the white portion 18 of the platen is uppermost so that the line of demarcation 15 and the initial character in the platen scale, printed in red, are in view and at a convenient place for adjusting the work sheet. Then the feed rolls 21 and 22 are released and the work sheet is slipped to position, which position places the upper edge 16 of the work sheet in an identical line with the line of demarcation 15 between the two colors of the platen and thus positions the first double spaced line that can be written on the work sheet in alignment with the initial character in the platen scale, 29, printed in red. The feed rolls 21 and 22 are then placed against the work sheet and the platen is rotated forward until the desired top margin is at the aligning scale, or writing line, of the machine, which top margin is selected by the use of any of the specified characters on the platen scale as they appear at the aligning scale, or writing line, of the machine. The writing is then begun.

For spacing the work sheet to position, the

platen is rotated forward until the black portion 19 of the platen is uppermost and the line of demarcation 14 between the two colors of the platen is at the aligning scale, or writing line, of the machine, as shown in Figures 7 and 9, which will also place the single indicium, or horizontal bar, printed in red, in the platen scale at the aligning scale, or writing line, of the machine as shown in Figures 7. The work sheet is then placed in the machine in engagement with the platen and the rearward feed rolls 21, which will place the upper edge of the work sheet in alignment with the line of demarcation 15 between the two colors of the platen. The platen is then rotated forward until the upper edge of the work sheet appears above the first double spaced line that can be written on the work sheet. This upper edge 16 of the work sheet will be identical with the line of demarcation 15 and the first double spaced line that can be written on the work sheet will be in alignment at the aligning scale with the initial character in the platen scale 29, which is printed in red. The platen is further rotated forward until the desired space for the top margin is at the aligning scale, or writing line, of the machine, which desired top margin is selected by use of the specified characters in the platen scale as they appear at the aligning scale, or writing line, of the machine. The writing is then begun.

For the top margin the operator can choose arbitrarily selected numerical indices in the platen scale relating to lines on the work sheet, which will also indicate the exact line being written soon after passing the middle of the page, commencing at line 19 and continuing to the bottom of the page; or the operator can choose the fractional dimensional symbols; or the operator can use as a guide any combinations of the two sets of platen scales that will best meet the needs of the particular writing to be done.

After selecting at will characters in the platen scale for the desired top margin no attention need be given the platen scale until the writing on the work sheet is beyond the middle of the page. Then the numerical indices in the platen scale, as they arrive at the aligning scale, or writing line, of the machine, or the full-number dimensional symbols, as they arrive at the aligning scale, or writing line, of the machine, will enable the operator easily to establish any designated spaces for foot notes, to put the same number of lines on consecutive pages, to keep top and bottom margins on consecutive pages uniform and to avoid writing too near the bottom of pages. Such arrival or the approach thereof will be signalled to the operator by changing color of the visible portion of the platen.

It will thus be seen that the principles of the invention are based upon the following relationships: the first and second lines of demarcation between the two colors of the platen; the aligning scale of the machine; the circumference of the platen, or the number of double-spaced lines that can be written on it during one complete revolution of the platen; the single indicium, or horizontal bar, in the platen scale; the initial character in the platen scale; the upper edge of the work sheet; and the length of the work sheet, or the number of double-spaced lines that can be written on it.

I am aware that prior to my invention numbers have been arranged in scales for the platens of typewriters, but, so far as is known, all those scales are different in principles of construction

and operation from the platen scales herein described and they do not have connected with them a platen of two colors with exact lines of demarcation between the two colors, which lines of demarcation combine with the upper edge of the work sheet and the characters in the platen scale to make the top and bottom margins accurate and easily selected and which colors provide a warning signal readily visible to the operator.

It will be understood that this invention is not limited to the specific structures herein shown and described but includes such modifications as come within the scope of the following claims.

The present application is a continuation-in-part of my application Serial No. 551,654, filed August 29, 1944.

I claim:

1. In a typewriter having a stationary index member and having rearward feed rolls spaced peripherally from the writing position to receive a work sheet, the combination of, a rotatable platen disposed in contact with said feed rolls and with its periphery adjacent said stationary index member, said platen having an end portion visible when the work sheet is inserted in the typewriter, a platen scale carried by and rotatable with said end portion and having indicia alignable with said index member to indicate the relationship of the writing position with respect to the work sheet, and a pair of opposed demarcation lines carried by and extending axially of the platen and so disposed relative to each other and to selected indicia on said platen scale that when the leading one of said lines in the direction of line spacing rotation of the platen is aligned with the stationary index member the trailing one of said lines is disposed adjacent the feed rolls to receive the leading edge of the work sheet in alignment therewith and in operative relationship with respect to said platen scale.

2. The structure of claim 1 wherein the peripheral portion of the platen lying between the demarcation lines is, for at least a portion of its length, of a color distinctive from the opposed peripheral portion of the platen whereby to provide a signal visible to the operator indicating the close approach of the trailing edge of the work sheet to the writing line of the typewriter.

3. The structure of claim 1 wherein the platen scale is provided with an indexing indicium in alignment with the leading one of said demarcation lines and alignable with the stationary index member and provided further with a character designating the initial work sheet writing line disposed in predetermined relation to the trailing one of said demarcation lines.

4. In a typewriter having a stationary index member marking a writing line and having rearward feed rolls spaced peripherally from the writing position to receive a work sheet, a rotatable platen disposed in contact with said feed rolls and with its periphery adjacent said stationary index member, said platen having a pair of opposed demarcation lines carried by and extending axially thereof and so disposed relative to each other that when the leading one of said lines in the direction of line spacing rotation of the platen is aligned with the stationary index member the trailing one of said lines is disposed adjacent the feed rolls to receive the leading edge of the work sheet in alignment therewith, the peripheral portion of the platen lying between the demarcation lines being, for at least a portion of its length, of a color distinctive from

the opposed peripheral portion of the platen whereby to provide a signal visible to the operator indicating the close approach of the trailing edge of the work sheet to the writing line of the typewriter.

5. In a typewriter having a stationary index member marking a writing line and having rearward feed rolls spaced peripherally from the writing position to receive a work sheet, a rotatable platen disposed in contact with said feed rolls and with its periphery adjacent said stationary index member, opposed peripheral areas of said platen being of distinctive colors, one of said areas extending substantially the peripheral distance between said index member and feed rolls to provide a guide for positioning the work sheet relative to the platen and the other of said areas providing a signal visible to the operator indicating the close approach of the trailing edge of the work sheet to the writing line of the typewriter.

6. The structure of claim 5 including a platen scale carried by and rotatable with said platen and disposed relatively to the signal area of the platen in a manner to indicate the writing space remaining on the work sheet when the signal is provided for the operator.

LOTTA ALLEN MEACHAM.

REFERENCES CITED

The following references are of record in the file of this patent:

* UNITED STATES PATENTS

| Number | Name | Date |
|-----------|-----------------------|---------------|
| 569,909 | Atwood ----- | Oct. 20, 1896 |
| 1,013,953 | Richardson ----- | Jan. 9, 1912 |
| 1,091,122 | Crowther et al. ----- | Mar. 24, 1914 |
| 2,030,395 | Pimentel ----- | Feb. 11, 1936 |
| 2,366,265 | Jensen ----- | Jan. 2, 1945 |