



- (51) International Patent Classification:
G06T 5/00 (2006.01) G06K 9/36 (2006.01)
- (21) International Application Number:
PCT/IL2017/050497
- (22) International Filing Date:
04 May 2017 (04.05.2017)
- (25) Filing Language:
English
- (26) Publication Language:
English
- (30) Priority Data:
62/331,521 04 May 2016 (04.05.2016) US
62/408,786 16 October 2016 (16.10.2016) US
- (71) Applicants: TEL HASHOMER MEDICAL RESEARCH, INFRASTRUCTURE AND SERVICES LTD. [IL/IL]; 64 Derech Sheba, 526200 Ramat Gan (IL). RAMOT AT TEL-AVIV UNIVERSITY LTD. [IL/IL]; P O Box 39296, 6139201 Tel Aviv (IL).
- (72) Inventors: MAYER, Arnaldo; Bialik 23/19, 4720616 Ramat Hasharon (IL). GREEN, Michael; Haimahot 6/1, 7648814 Rehovot (IL). KIRYATI, Nahum; Kashani 7, 6949911 Tel Aviv (IL). MAROM, Edith M.; Tagor 44, 6934102 Tel Aviv (IL). KONEN, Eli; Shalom Levin 24, 6962118 Tel Aviv (IL).
- (74) Agent: ANTIS, Allan et al.; A.C. ENTIS-IP LTD., 6 Raoul Wallenberg, 69719 Tel Aviv (IL).
- (81) Designated States (unless otherwise indicated, for every kind of national protection available): AE, AG, AL, AM, AO, AT, AU, AZ, BA, BB, BG, BH, BN, BR, BW, BY, BZ, CA, CH, CL, CN, CO, CR, CU, CZ, DE, DJ, DK, DM, DO, DZ, EC, EE, EG, ES, FI, GB, GD, GE, GH, GM, GT, HN, HR, HU, ID, IL, IN, IR, IS, JP, KE, KG, KH, KN, KP, KR, KW, KZ, LA, LC, LK, LR, LS, LU, LY, MA, MD, ME, MG, MK, MN, MW, MX, MY, MZ, NA, NG, NI, NO, NZ, OM, PA, PE, PG, PH, PL, PT, QA, RO, RS, RU, RW, SA, SC, SD, SE, SG, SK, SL, SM, ST, SV, SY, TH, TJ, TM, TN, TR, TT, TZ, UA, UG, US, UZ, VC, VN, ZA, ZM, ZW.
- (84) Designated States (unless otherwise indicated, for every kind of regional protection available): ARIPO (BW, GH, GM, KE, LR, LS, MW, MZ, NA, RW, SD, SL, ST, SZ, TZ, UG, ZM, ZW), Eurasian (AM, AZ, BY, KG, KZ, RU, TJ, TM), European (AL, AT, BE, BG, CH, CY, CZ, DE, DK, EE, ES, FI, FR, GB, GR, HR, HU, IE, IS, IT, LT, LU, LV, MC, MK, MT, NL, NO, PL, PT, RO, RS, SE, SI, SK, SM, TR), OAPI (BF, BJ, CF, CG, CI, CM, GA, GN, GQ, GW, KM, ML, MR, NE, SN, TD, TG).

(54) Title: METHOD AND SYSTEM FOR PROVIDING A LOCALLY-CONSISTENT ENHANCEMENT OF A LOW-QUALITY IMAGE

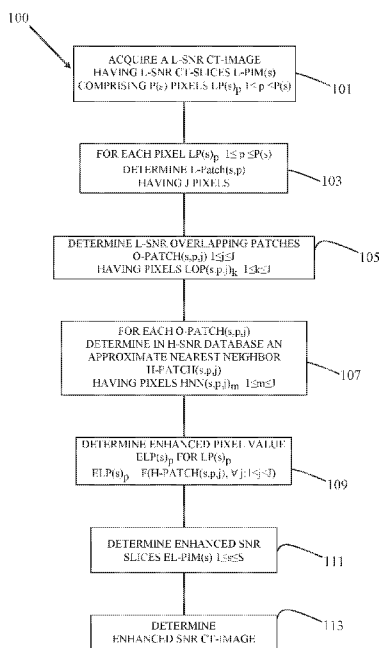

FIG 2

(57) Abstract: A method of providing a medical image of a ROI of a patient, the method comprising: acquiring a first medical image of a region of interest (ROI) of a patient, the medical image characterized by a first signal to noise ratio (SNR); determining for a given pixel in the first image a plurality of different first image patches in the first image, each having a pixel that is coincident with the given pixel; determining for each first image patch a similar second image patch having a second SNR greater than the first SNR; determining an enhanced pixel value for the given pixel having an enhanced SNR greater than the first SNR responsive to pixel values of pixels in the determined second image patches; and using the determined pixel value to generate a second medical image of the ROI having an enhanced SNR greater than the first SNR.



Published:

- *with international search report (Art. 21(3))*
- *before the expiration of the time limit for amending the claims and to be republished in the event of receipt of amendments (Rule 48.2(h))*

METHOD AND SYSTEM FOR PROVIDING A LOCALLY-CONSISTENT ENHANCEMENT OF A LOW-QUALITY IMAGE

RELATED APPLICATIONS

[0001] This application claims benefit under 35 U.S.C. 119(e) of U.S. Provisional Applications 62/331,521, filed May 4, 2016 and 62/408,786, filed October 16, 2016, the disclosures of which are incorporated herein by reference

BACKGROUND

[0002] Medical imaging such as performed by a CT (computed tomography), a MRI (magnetic resonance imaging) scanner or the like, may require that a patient be scanned for a length of time during which the patient is subject to uncomfortable and/or undesirable physical and psychological conditions. The patient may have to endure not only an uncomfortably long exposure period, or an uncomfortable physical position during an exposure period, the patient may also be exposed to an undesirable amount of energy that the scanner generates to acquire the image. For example, patients very often experience psychological discomfort anticipating confinement in or being confined in an MRI imager for an extended period of time, and an amount of radiation to which a patient may be exposed during a CT scan can be dangerous to the patient's health. However, reducing patient scanning time in an MRI scanner or reducing an amount of radiation to which a patient is exposed during a CT scan generally damages quality of the image and typically reduces image SNR. Also, a prolonged scanning time or a high radiation dose do not necessarily ensure a high quality image since such an image is also dependent on other factors like, for instance, undesirable artifacts.

SUMMARY

[0003] An aspect of this disclosure relates to providing a medical imaging system ("imaging system") comprising a medical imaging device (or, in short, "imaging device") configured to acquire a relatively low-quality medical image ("L-image") of any region of interest (ROI) in a physical body and in particular, but not exclusively, a ROI of a patient, and process the L-image in order to provide an image ("E-image") which is enhanced in quality in comparison to the L-image.

[0004] The term "quality", in connection with an image in this application, means a degree to which said image is suitable for analysis and/or diagnosis and/or data gathering and/or evaluation of any kind. Moreover, in this application the term "quality" in all its forms, abbreviations, derivations etc. whether explicit or implied, does not mean or set – unless expressly stated

otherwise – any specific value, level or standard and is to be understood in a relative or contextual manner.

[0005] The ROI may be any part, organ or region of the human body (where the term "body" includes any and all physical aspects of the living or dead organism of a human being or an animal, including head, trunk, limbs, internal or external organs, skins, bones, appendages, extremities etc.) and/or any section, slice, segment or fragment thereof. In specific embodiments of the disclosure, the term "ROI" may also refer to a part or the entirety of any organic or inorganic object, material or medium.

[0006] The term "image" in this application means any type of visual representation, including one-dimensional, bidimensional, tridimensional or any other kind of space or combination thereof. Additionally, the term "image" in this application, alone or in conjunction with any other term, may apply, according to the case, to one or more parts or layers of an image like, for instance, one or more slices of a CT, MRI or PET scan or to the complete set and/or composite of said slices, which form the complete scan (or, in short "scan"). Furthermore, the term "image" in this application applies, according to the case, both to raw acquisition data – for example, a CT sinogram or an MRI k-space matrix acquired by an imaging device – or the image resulting from any intermediate or final processing of said raw data.

[0007] Additionally, the term "image" in this application applies to any data that can be visually represented including, for instance, data related to sound, pressure, temperature and so forth.

[0008] In an embodiment of the disclosure the imaging system includes and/or has access to a high-quality database ("H-database") which may be located anywhere and which contains high-quality image/s ("H-image/s") and/or patch/es ("H-patch/es"), optionally extracted from said H-images and comprising relatively small regions of said H-images. The H-images and/or the H-patches, which may be stored in any convenient manner are relevant to the L-image/s and/or corresponding low-quality patches ("L-patch/es") that the imaging systems may be configured to acquire and might need to be enhanced.

[0009] The term relevant, in the context of an embodiment of the disclosure, means that the images or patches extracted from the H-database contain information that can be used to enhance the L-images or L-patches. Therefore, the H-database will typically contain images of items related to the items in L-images. For example, if an L-image of brain CT scan is to be enhanced, the H-database used for that purpose should also contain H-images and H-patches of brain CT scans. Moreover, the term relevant may also mean that the H-database used to enhance an L-image contains H-images and H-patches having a physical pixel size compatible with the L-

image, L-patch, physical pixel size. If desired, adjustments of the physical pixel size may be easily performed using methods well known in the art.

[00010] Said H-image and/or H-patches – as well as L-image and or L-patches - may or may not have been acquired using the imaging system described in this disclosure and, more generally, said images may have been acquired at any point of time and/or in any sequence and/or for any patient and/or for any ROI and/or in any location and/or by any suitable means.

[00011] The imaging system may comprise a processor ("E-processor") that uses H-images or H-patches from a H-database to process L-images or L-patches of a ROI of a patient to provide an enhanced image (hereinafter "E-image") of the ROI.

[00012] A patch and a pixel in an E-image may be also referred to as "E-patch" and "E-pixel". Similarly, a pixel in a H-patch or in a L-patch may also be referred to as "H-pixel" and "L-pixel".

[00013] In the specific case that the enhancement in said E-image is obtained by achieving an enhanced SNR, which enhancement may also be referred to as "de-noising", said image may also be referred to as an "E-SNR image" or a "de-noised image". The term "E-image" also encompasses any image which undergoes, as described in this disclosure, a quality improvement – not necessarily an improvement in SNR, – in respect to a relatively low quality image (or, in short "L-image") – not necessarily a L-SNR image. A non-SNR improvement may be, the attenuation of image artifacts such, for example, streak artifacts in CT images, calcium blooming in coronary CT angiography images, or ringing artifacts in MRI images.

[00014] A process of enhancing an L-image, in accordance with an embodiment, may be carried out on pixels that belong to the L-image. A resulting image, after quality enhancement in accordance with an embodiment, may be referred to as an "E-image".

[00015] The term "processor", used interchangeably in this application with the term "E-processor", means any device, element, component or combination thereof, capable of carrying out one or more of actions according to this disclosure, in order to acquire, obtain, view, process or, in general, manage, alter, and/or manipulate an image and capable of enhancing a L-image as to obtain an E-image.

[00016] An E-processor in accordance with an embodiment of the disclosure may comprise, one or more of the following elements - a general purpose or dedicated device, a PC, a processor, a controller, circuit, an IC, any combination thereof, a biocomputer, biologically based components, biomolecular components, where the term "combination", throughout this application means, for the processor, as well as for all the other elements and/or components of the system, any possible configuration that enables the cumulative, alternative, or parallel

structuring, and/or usage of hardware and/or software and/or tangible and/or intangible components and/or elements in any integration, distribution, arrangement, addition, replacement or exclusion, system, location, type of connection, material, time sequence and physical and/or virtual presence and/or distribution of the aforementioned.

[00017] In order to practice an embodiment of the disclosure the processor may carry out any operation which may, for example, be contained in, and/or provided by, one or more of the following: a program, instructions algorithm, routine, logic, rule, process flow, operation, function, process, and any combination thereof (hereinafter the "operation elements" or "enhancement operation elements") which operation elements can be, partially or entirely, implemented in at least one one or any combination of more than one of the following forms: software, hardwired, printed circuit and so forth.

[00018] Accordingly, the term "processor" in this application must be understood as the processor being equipped with the necessary operation enhancement elements which may, of course, vary in different embodiments.

[00019] The term "equipped" in relation to the processor and the operation elements means, one or more of the possible ways or combinations in which the processor and the operation elements may be configured to work together including, for example, by way of inclusion, installation, integration, distribution, presence in different devices working in conjunction in any manner whatsoever, including in any type of network.

[00020] The processor may be a dedicated one or a general purpose processor equipped with the enhancement operation elements. The processor is, preferably, also capable of carrying out all standard computer activities, which include interfacing the other hardware and/or software elements of the system, peripheral devices, communication devices, networks, managing data and so forth ("standard computer activities").

[00021] It is noted that specific embodiments of the disclosure may require more than one processor working separately or in conjunction. Additionally, the processor may be, according to the embodiments, a single processor or a plurality of processors the combination of which and/or the cumulative operation of which provides the requirements and functionalities of an embodiment of the disclosure and/or standard computer activities. Operations described hereinafter are intended as being performed by the processor and/or by its mediation with other devices, unless explicitly stated otherwise.

[00022] According to an embodiment of the disclosure, in order to enhance the quality of an L-image to provide an E-image for the L-image, the processor may select a given pixel " p_j " to be

enhanced ("the given pixel"). Then, the processor may define a patch (L-patch) of pixels that includes pixel p_j , which may also be referred to as a reference pixel. The subscript "j" in " p_j " stands for a generic pixel position - generally indicated by a value in the L-image. Obviously, when a different pixel in the L-image is considered, the value of j changes according to the pixel position. The value of j is therefore defined by $1 \leq j \leq$ a number of pixels in L-image. It goes without saying that many alternative ways for addressing a given pixel may be used. For instance, instead of defining the absolute position a pixel in the L-image, the position of a pixel may be defined as a relative position based on the pixel's position in a specific L-patch using a Patch-number index and a pixel-position index within the specific patch. However, alternative ways for addressing the pixel and/or a patch, do not change in any manner the nature of the disclosure.

[00023] For the sake of simplicity and for illustration purposes only, the L-patch is hereinafter described as a square patch and the given pixel " p_j " is defined as a central pixel in said L-patch but, according to an embodiment, a shape of an L-patch may vary in any convenient or desirable manner.

[00024] The L-patch extracted as an example in in Fig. 3 is a square $P_s \times P_s$ patch where $P_s = 3$, which is a shorthand for indicating a patch ("P") having a side length ("s") of three pixels and consisting of 9 pixels which can also be indicated as $P_s^2 = 9$. And successful experimental results have been obtained for $P_s = 5$ by the inventors. For avoidance of any doubt, "side length" means the number of pixels that form said side. Also the term "size" in connection with a patch means the number of pixels contained in said patch. Thus, for instance, a square having a side length of seven pixels can be indicated as $P_s^2 = 49$. An alternative notation for the number of pixels can be P_N , in this case $P_N = 49$. Moreover, the shape of a patch, according to the disclosure, is not limited to squares and a patch may be such as $P_{s1} \times P_{s2}$ whereby $s1 \neq s2$ - for instance, $P_{s1} = 5$, $P_{s2} = 11$ and $P_{s1} \times P_{s2} = 55$. Furthermore, one or more sides of the patch may consist of an even number of pixels. The verb "extract", in reference to a patch may mean "define" or "select" the patch regardless whether or not the patch is copied, cut, duplicated, deleted or otherwise disposed of.

[00025] Furthermore, , wherever applicable in specific embodiments of the disclosure, the term "pixel" in this application, may be used interchangeably or accumulatively with the term "voxel" that is, a volumetric pixel or "3D-pixel". Consequently, where applicable, a patch may be indicated as P_s^3 , if all sides of the patch are equal (both even or odd) and may be indicated as

$P_{s1}^2 \times P_{s2}$ if only two sides are of equal size or $P_{s1} \times P_{s2} \times P_{s3}$ if all sides are different for example, in a $(5 \times 7 \times 13)$ patch or in a $(4 \times 9 \times 6)$ patch.

[00026] Generally speaking, an embodiment in accordance with the disclosure does not require a patch to be of any specific size or shape and the patch may be of any shape suitable for the purposes of an embodiment of the disclosure. Generally any shape that tiles a region of an ROI may be advantageous. If a patch used for a specific embodiment does not contain a given pixel p_j that is the central pixel in the patch, unlike in the $P_s^2 = 9$ patch used as example in the description of an embodiment, another pixel may be defined as a reference pixel. Whichever size or shape is used throughout the invention, the total number of pixels which forms the patch may be generally indicated in the invention as P_N . As for the type of pixel value (" $V(p_j)$ "), this can be of any desired real, complex or other numerical type.

[00027] Now, according to the currently described embodiment of the disclosure, a patch (L-patch), around a selected given pixel p_j of the L-patch is defined. Then, P_N distinct patches (O-patches) that have the same size as the L-patch and contain pixel p_j , are defined. Where the term "distinct" means that there is no total overlap between any 2 or more O-patches. Notwithstanding the above, there may be a total overlap between a single one of the O-patches and the L-patch. After the O-patches have been determined, a corresponding H-patch for each of the O-patches is determined and extracted (or in short "returned") from a relevant H-database whereby the H-patch exhibits a degree of similarity to the corresponding O-Patch, that is, satisfies a desired similarity criterion. The H-patches are returned from the H-database so that in each specific case the size of the determined O-patch and the size of the returned H-patch are the same. In a variation of the embodiment more than one H-patch may be returned for each O-patch.

[00028] A variety of high-quality data sources ("H-source"), may be used, in addition to or instead of the H-database, for returning a H-patch for each O-patch. The returned H-patch advantageously exhibits a desired degree of similarity to the O-Patch, that is, satisfies a desired criterion. For example, the H-patch may be returned by determining an approximate nearest neighbor (ANN) of the O-patch. It is noted that the term "approximate nearest neighbor", relates to a degree of similarity between the O-patch and the H-patch, optionally, represented by one-dimensional vectors. It is noted that the ANN approach is only an exemplary approach, and many other suitable criteria, well known in the art, may be used. In addition or alternative to returning an H-patch from a H-database, an H-patch, may also be returned, from other H-sources, which can be used to provide data relevant to the L-image. For instance: a neural network after prior

appropriate training. It is noted that the term "source" in this application, in relation to images and/or patches of any kind and quality and their relative databases, contains, but is not limited to, said images and/or patches and/or databases. Thus, for example, the term "H-database" is contained in the term "H-source". The H-source, L-source and E-database typically contain very large amounts of data (BIG DATA) required for image enhancement according to this disclosure, which may be best, but not exclusively, to store them in the cloud.

[00029] A set of H-patches returned for the O-patches of the pixel p_j may be indicated as " NNp_j " or $\{NNp_j\}$ which stands for "the set of H-patches which are the approximate nearest neighbors of the O-patches extracted from the H-database or H-source. In the current example, $P_s^2 = 9$ patches are extracted.

[00030] It should be noted that while all the O-patches contain the given pixel value, $V(p_j)$, there is no requirement that all or even any of the H-patches returned for the O-patches contain any pixel value that is the same or close to $V(p_j)$ or, more generally, that has any degree of similarity with value $V(p_j)$, but only that each returned H-patch for the respective O-patch be considered as, optionally, entirely overlapping its respective O-patch.

[00031] Next, the processor computes an enhanced pixel value (" \hat{p}_j ") for the given pixel p_j as a function of the patches belonging to NNp_j as follows:

$$\hat{p}_j = F(\hat{P}_1, \dots, \hat{P}_{P_s^2}) \text{ for } \hat{P}_i \in (NNp_j), \quad (1)$$

where, \hat{p}_j is, obtained by applying a function " F " on the H-patches $(\hat{P}_1, \dots, \hat{P}_{P_s^2})$, which H-patches belong to the set NNp_j , $F(X): \mathcal{R}^{P_s^2} \rightarrow \mathcal{R}$, and $i=1, \dots, P_s^2$

Different choices may be made for function F . Below, three nonlimiting examples of the many possible choices for the function F are discussed. A simple choice of F may be the average value of all the pixels of the H-patches which share the same location as the given pixel, leading $\hat{p}_j =$

$$\frac{1}{P_s^2} \sum_{i=1}^{P_s^2} \hat{P}_{ij} \text{ for } \hat{P}_i \in (NNp_j) \quad (2)$$

where \hat{P}_{ij} stands for pixel value in patch \hat{P}_i at the location overlapping with pixel p_j . In this approach, each overlapping patch \hat{P}_i contributes to the enhanced value \hat{p}_j via its pixel \hat{P}_{ij} , which is the way low-quality pixel p_j is "perceived" by the H-patch \hat{P}_i .

[00032] Another example of possible choice for F , is to weight the contributions $\widehat{\mathbf{P}}_{i_j}$, $i = 1 \dots P_S^2$ by a distance measure between $\widehat{\mathbf{P}}_i$ and the original L-patch defined around p_j , formalized as follows:

$$\hat{p}_j = \frac{\sum_{i=1}^{P_S^2} \exp\left(-\frac{D(p_j, \widehat{\mathbf{P}}_i)}{h^2}\right) \widehat{\mathbf{P}}_{i_j}}{\sum_{i=1}^{P_S^2} \exp\left(-\frac{D(p_j, \widehat{\mathbf{P}}_i)}{h^2}\right)}, \widehat{\mathbf{P}}_i \in (NN_{p_j}), \quad (3)$$

where $h = P_S \cdot \gamma$ is a filtering parameter and γ a constant, $\widehat{\mathbf{P}}_j$ is the L-patch defined around pixel p_j , and $D(p_j, \widehat{\mathbf{P}}_i)$ is the average L1 (or another L_n norm for $n > 1$) distance between the overlapping pixels of $\widehat{\mathbf{P}}_j$ and $\widehat{\mathbf{P}}_i$. Thus, surrounding $\widehat{\mathbf{P}}_i$ H-patches with high similarity to $\widehat{\mathbf{P}}_j$ at their overlap will contribute more to the enhanced value \hat{p}_j , for pixel p_j .

[00033] Bearing in mind that pixel p_j has already been defined as a two-dimensional pixel or a three-dimensional voxel, the two examples of functions F described above can be generalized as to apply to any bi-dimensional or three-dimensional patch with any number of pixels P_N with any side size combination. Furthermore, said functions can be generalized as to apply to any image-source (H-source, L-source, E-source) and the respective patches of said sources, including any approximate neighbor of any bi-dimensional or three-dimensional patch. Accordingly, formula (3) can be generalized as follows:

$$\hat{p}_j = \frac{\sum_{i=1}^{P_N} \exp\left(-\frac{D(p_j, \widehat{\mathbf{P}}_i)}{P_N \cdot \beta}\right) \widehat{\mathbf{P}}_{i_j}}{\sum_{i=1}^{P_N} \exp\left(-\frac{D(p_j, \widehat{\mathbf{P}}_i)}{P_N \cdot \beta}\right)}, \widehat{\mathbf{P}}_i \in (NN_{p_j}) \quad (4)$$

Where $P_N \cdot \beta > 0$ is a filtering parameter and β is a constant. Similarly, formula (2) can be generalized as follows:

$$\hat{p}_j = \frac{1}{P_N} \sum_{i=1}^{P_N} \widehat{\mathbf{P}}_{i_j} \text{ for } \widehat{\mathbf{P}}_i \in (NN_{p_j}) \quad (5)$$

And formula (1) can be generalized as follows:

$$\hat{p}_j = F(\widehat{\mathbf{P}}_1, \dots, \widehat{\mathbf{P}}_{P_N}) \text{ for } \widehat{\mathbf{P}}_i \in (NN_{p_j}) \quad (6)$$

Whereby \hat{p}_j is obtained by applying a function "F" on the H-patches $(\widehat{\mathbf{P}}_1, \dots, \widehat{\mathbf{P}}_{P_N})$ which H-patches belong to the set NN_{p_j} . where $F(X): \mathcal{R}^{P_N} \rightarrow \square$ and $i=1, \dots, P_N$

[00034] A further example of possible choice for F is a neural network that has been trained beforehand to map H-patches, corresponding to the O-patches containing pixel p_j , onto an enhanced value for \hat{p}_j for the pixel. It is noted that if the H-source which provided the H-patches

is also a neural network, the function F in this current example of possible choice of F is a second neural network, different from the first neural network that constituted the H-source.

[00035] Now, after one of the possible F functions has been applied, the value of pixel p_j ($V(p_j)$), is replaced with \hat{p}_j , which is the enhanced pixel value ("EPV") of p_j . The processor may repeat the pixel-enhancement process described above for each a plurality of different given pixels p_j in the L-image in order to provide, for each of said pixels an enhanced pixel value ("EPV"), which can be used to provide an E-image based on the L-image.

[00036] In an embodiment to further boost the enhancing effect, the newly obtained E-image may be defined as an L-image⁽¹⁾ to which the image enhancement process is repeated to obtain a further enhanced E-image⁽¹⁾ and the process may be repeated n times to obtain an enhanced L-image⁽ⁿ⁾, E-image⁽ⁿ⁾, which may serve as an E-image for the original L-image.

[00037] As it can be appreciated from all said above, the invention object of this application makes use, among other things, of a Locally-Consistent approach whereby each one the O-patches can be considered as proposing - through its corresponding H-patch - an enhanced value of p_j , that fits well with neighboring pixels in the H-patch, thus promoting the preservation of spatial local-consistency. In other words, the resulting enhanced value of p_j (EPV) reflects the way in which each of the O-patches perceives pixel the value p_j ($V(p_j)$)

[00038] An aspect of the disclosure therefore comprises a method for providing a Locally-Consistent enhancement of a Low-Quality image (L-image) resulting in an Enhanced Image (E-image), comprising the following steps:

- (i) Selecting a pixel of the L-image to be enhanced;
- (ii) Defining around the selected given pixel, a patch (L-patch), whereby the given pixel is pixel p_j of the L-image;
- (iii) Defining P_N distinct (O-patches) that have the same size as the L-patch, contain pixel p_j and have a certain overlap with the L-patch; and
- (iv) For each O-patch, returning from a relevant high-quality source (H-source), a high quality patch (H-patch) that exhibits a desired degree of similarity to said O-Patch, that is, satisfies a desired criterion but does not necessarily contain a pixel value that is equal or close to the value $V(p_j)$ of pixel p_j ;
- (v) Computing an enhanced pixel value (EPV) for p_j , which EPV enhances the quality of pixel p_j , by applying a function $F(\underline{X})$ to the H-patches in (iv);

(vi) Replacing the pixel value of p_j with the EPV; and

(vii) If desired, repeating steps i to vii.

[00039] According to another embodiment, the disclosure relates to a system for providing a Locally-Consistent enhancement of a Low-Quality image (L-image) resulting in an Enhanced Image (E-image). Fig. 4, schematically shows a system 400 for providing E-images of L-images in accordance with an embodiment of the disclosure. System 400 optionally comprises an E-processor (402) interfaced to an H-database (403) and an L-database (404). The E-processor (402) in this embodiment may be a PC communicating with a PACS (Picture Archiving and Communication System) (405) which is a system used in medical imaging to store, retrieve, distribute, analyze, and digitally process medical images.

[00040] System 400 is equipped with a standard network connectivity and Digital Imaging and Communications in Medicine (DICOM) (411) that is a standard for handling, storing, printing, and transmitting information in medical imaging. DICOM includes a file format definition and a network communications protocol.

[00041] The E-processor (402) uses the above described network and DICOM connectivity and file format in order to acquire, obtain, view, create, read, write, store, process or, in general, transmit, receive, manage, alter, edit or manipulate images present in the PACS (405) which serves both as an L-source and an H-source. The images stored in the PACS (405) originate from a medical imaging modality (401) such as a CT scanner, an MRI scanner, or a mammography apparatus, etc. The images may also be obtained by the E-processor (402) directly from the medical imaging modality (401). Alternatively or additionally, H-patches may be obtained from a neural network (406) trained by a deep learning algorithm and method.

[00042] The E-processor (402) is equipped with enhancement operation elements (410), capable of outputting and/or inputting L-images and/or H-images from and/or to said L-source and/or said H-source, and capable of processing, according to the method of the disclosure, said L-images and/or said H-images as to obtain E-images and, optionally, an E-database (412) for storing the obtained E-images.

[00043] The system may further comprise a radiologic workstation (407) communicating with the PACS system (405), for the retrieval of the E-images and their visualization by a physician on display (408) Using an image viewer, for example, a DICOM viewer.

[00044] The system may additionally include at least at the radiologic workstation (407) a suitable human-machine interface (HMI) (409) comprising, for example, keyboards and similar peripheral devices, speech-recognition interfaces and so forth.

[00045] Optionally, the display (408) capable of displaying L-images, H-images and E-images is, preferably, but not necessarily, a medical diagnostic display.

[00046] The elements comprised in the system may be arranged in any suitable combination. For instance, the system may be structured using different devices and components operating in conjunction as described above or may feature different degrees of integration. In an embodiment described hereinafter in the detailed description, the system is integrated in a CT scanner.

[00047] Conversely, the system could be adopt a more distributed architecture wherein the E-processor, as well as the H-database and L-database, could be located on cloud based virtual machine and storage.

[00048] In an embodiment of the disclosure a system for providing a Locally-Consistent enhancement of a Low-Quality image (L-image) resulting in an Enhanced Image (E-image) may comprise:

- an E-processor (402) including enhancement operation elements (410), optionally, including a neural network (406) trained by a deep learning algorithm and method;

- a H-database (403) and an L-database (404);

- a PACS (Picture Archiving and Communication System) (405) connected through DICOM (411) protocol to E-processor (402), H-database (403) and an L-database (404);

- a standard network connection between the E-processor (402), H-database (403) and L-database (404);

- a medical imaging modality (401) such as a CT scanner, an MRI scanner, or a mammography apparatus, etc. connected to the E-processor (402);

- a radiologic workstation (407) with suitable image viewer and communicating with the PACS system (405), for the retrieval of the E-images and their visualization;

- a display (408) preferably, but not necessarily, a medical diagnostic display; and

- a suitable human-machine interface (HMI) (409).

[00049] The elements comprised in the system may be arranged in any suitable combination. For instance, the system may be structured using different devices and components operating cooperating as described above or may feature different degrees of integration. In an embodiment described hereinafter in the detailed description, the system is integrated in a CT scanner. Conversely, the system could be adopt a more distributed architecture wherein the E-processor, as well as the H-database and L-database, could be located on cloud based virtual machine and storage

[00050] In a further embodiment, the medical imaging system comprises a CT scanner and the L-image is an L-SNR CT-image of an ROI of patient acquired exposing the patient to a relatively low dose of X-ray radiation.

[00051] In yet another embodiment, the medical imaging system comprises an MRI scanner and the image is an L-SNR MRI image of an ROI of a patient acquired under scanning conditions resulting in a relatively low SNR image. For example the L-SNR MRI image may have been acquired using a relatively weak magnetic polarizing field, a relatively short scanning period of the patient, and/or for a diffusion weighted MR scan using elevated diffusion weighting values.

BRIEF DESCRIPTION OF FIGURES

[00052] Non-limiting examples of embodiments of the disclosure are described below with reference to figures attached hereto that are listed following this paragraph. Identical features that appear in more than one figure are generally labeled with a same label in all the figures in which they appear. A label labeling an icon representing a given feature of an embodiment of the disclosure in a figure may be used to reference the given feature. Dimensions of features shown in the figures are chosen for convenience and clarity of presentation and are not necessarily shown to scale.

[00053] Fig. 1A schematically shows a CT scanner configured to acquire L-SNR CT-images of a patient and process the images to provide enhanced, E-SNR, CT-images of the patient, in accordance with an embodiment of the disclosure;

[00054] Fig. 1B shows schematic distribution of signal variances of H-Patches optionally comprised in a H-SNR patch database, in accordance with an embodiment of the disclosure;

[00055] Fig. 2 shows a flow diagram of a procedure that the CT scanner shown in Fig. 1 may use to provide E-SNR images based on L-SNR images, in accordance with an embodiment of the disclosure;

[00056] Figs. 3A schematically shows an L-Patch determined for a given pixel in an image of a CT-slice of a patient, in accordance with an embodiment of the disclosure;

[00057] Figs. 3B--3J schematically show overlapping O-Patches determined for the given pixel and L-Patch shown in Fig. 3A, in accordance with an embodiment of the disclosure; and

[00058] Fig. 4 schematically shows a system operable to provide enhanced quality images, E-images, based on enhancing low quality, L-images, in accordance with an embodiment of the disclosure.

DETAILED DESCRIPTION

[00059] In the detailed discussion below features and operation of a medical imaging system configured in accordance with an embodiment of the disclosure to enhance a L-image to obtain a E-image of a patient are discussed with reference to Fig. 1. Details of a procedure by which the imaging system shown in Fig. 1 may process an L-image of a patient that the imaging system acquires to provide an E-image based on the acquired image, are discussed with reference to Fig. 2. By way of example, the medical imaging system shown in Fig. 1 comprises a CT-scanner. It is noted that in addition to certain imager types mentioned in the specific exemplary embodiments, the imager according to the disclosure may comprise at least one or any combination of more than one of a device suitable for: x-ray radiography, mammography, fluoroscopy, angiography, ultra-sound imaging, positron emission tomography (PET), computed tomography (CT), magnetic resonance imaging (MRI), and any combination thereof.

[00060] In the discussion, unless otherwise stated, adjectives such as “substantially” and “about” modifying a condition or relationship characteristic of a feature or features of an embodiment of the disclosure, are understood to mean that the condition or characteristic is defined to within tolerances that are acceptable for operation of the embodiment for an application for which it is intended. Unless otherwise indicated explicitly or implicitly, the word “or” in the description and claims is considered to be the inclusive “or” rather than the exclusive or, and indicates at least one of, or any combination of items it conjoins.

[00061] Fig. 1 schematically shows, in accordance with an embodiment of the disclosure, a multislice CT-scanner 20 configured to acquire low-dose CT-images characterized by a relatively low SNR of patients and process the images to provide enhanced images (E-images), which are characterized by enhanced SNR as well, possibly, by other quality enhancements. In Fig. 1, by way of example, CT-scanner 20 is shown imaging a ROI of the chest of a patient 22.

[00062] CT-scanner 20 comprises a gantry 34 having a stator 35 to which a rotor 36 is mounted so that the rotor can be controlled to rotate about an axis 37. An X-ray source 24 controllable to provide an X-ray beam schematically indicated by dashed lines 26 and an array 30 of X-ray detectors 32 opposite the X-ray source are mounted to the rotor. Detectors 32 generate signals that provide measures of intensity of X-rays from X-ray source 24 that pass through a patient imaged by CT-scanner 20. CT-scanner 20 is assumed, by way of example to be a multislice CT-scanner that simultaneously images a plurality of “CT-slices” of the body of a patient and detectors 32 in array 30 are configured in a plurality of contiguous curved rows 33 of the detectors. By way of example, in Fig. 1, for convenience of presentation CT-scanner 20 is shown

as controllable to simultaneously image up to four CT-slices of a patient. The patient, such as patient 22, is supported on a couch 38 mounted to a suitable pedestal (not shown) so that the couch is controllable to be translated axially along axis 37 selectively in a direction indicated by a block arrow 39 or in a direction opposite the indicated direction. Detectors 32 in detector array 30 and features of CT-scanner that are shadowed by patient 22 and couch 38, which would not normally be seen in the perspective of Fig. 1, are shown for clarity of presentation by ghost lines.

[00063] A controller 50 controls operation of CT-scanner 20 and processing of signals generated by detectors 32 to provide a CT-image of a patient. Controller 50 optionally comprises a scanner controller 51 that controls operation of components of CT-scanner 20, data acquisition circuitry 52, a memory 53, and a processor 55.

[00064] In an embodiment of the disclosure controller 50 comprises a H-SNR database 54 comprising a plurality of H-SNR images of different regions of a human body for which CT-scanner 20 may be used to acquire images, and/or H-SNR image patches, H-Patches, extracted from H-SNR images for each of different regions of the body for which the CT-scanner may be used to acquire images. In an embodiment H-SNR database 54 comprises H-Patches that have been extracted from H-SNR images and been selected so that a population of H-Patches comprised in the database exhibits a relatively large number of H-Patches having significant information content. Signal variance of an H-patch may be used as a measure of information content of an H-Patch, with relatively large signal variance indicating relatively large information content. Signal variance of an H-Patch refers to a standard deviation of X-ray intensities represented by values, for example gray level values, of the pixels in the H-Patch. In an embodiment, extracted H-Patches are filtered using a roulette wheel selection filter to provide a population of H-Patches exhibiting greater signal variance than a population of extracted H-Patches filtered randomly. By way of example Fig. 1B shows a distribution 57 of a population of H-Patches filtered randomly and a distribution 58 of a population of H-Patches selected using a roulette wheel filter to increase presence of H-Patches having relatively large signal variance in accordance with an embodiment of the disclosure.

[00065] Controller 50 may comprise any electronic and/or optical processing and/or control circuitry, to provide and enable functionalities that the controller may require to support its operation in embodiments that are described below and embodiments similar to the described embodiments. By way of example, processor 55 may comprise any one, or any combination of more than one of, a microprocessor, an application specific circuit (ASIC), field programmable array (FPGA) and/or system on a chip (SOC). Memory 53 may comprise any electronic and/or

optical circuitry suitable for storing data and/or computer executable instructions and may, by way of example, comprise any one or any combination of more than one of a flash memory, random access memory (RAM), read only memory (ROM), and/or erasable programmable read-only memory (EPROM).

[00066] Whereas memory 53, H-SNR database 54, and/or processor 55, are indicated in Fig. 1A as being centralized local modules comprised in CT-scanner 20, at least one of the modules may be a virtual module and/or may be configured as a distributed module comprising hardware and/or software components at different locations outside of CT-scanner 20, and may be cloud based. For example H-SNR database 54 and/or processor 55 may be a cloud based database and controller 50 may comprise and/or have access to any suitable wire and/or a wireless communication interface (not shown) for communicating with the H-SNR database and/or processor.

[00067] To image a ROI of a patient's body, such as the chest region of patient 22, system controller 50 controls couch 38 to translate the patient through gantry 34 so that the ROI passes through the gantry. While translating the patient through the gantry, system controller 50 controls X-ray source 24 to generate fan beam 26 and rotor 36 to rotate about axis 37 so that the fan beam exposes the patient to X-rays from a plurality of different "view angles" in a range of about 360° about axis 37. For each of the view angles, detectors 32 provide signals that measure intensities of X-rays in fan beam 26 that pass through the ROI of the patient located between detectors 32 and X-ray source 24. For each view angle rows 33 of detectors 32 provide measurements of X-ray intensity useable to generate images of optionally four different CT-slices of the patient. Fig. 1 schematically shows four exemplary CT-slices 40 of patient 22 for which CT-scanner 20 acquires intensity measurements of X-rays that have passed through patient 22 for the position of patient 22 in gantry 34 and a view angle of about 90° at which X-ray source 24 and detector array 30 are shown in the figure. The intensity signals generated by detectors 32 may be received by data acquisition circuitry 52 which may preprocess and store the preprocessed signals in memory 53. Processor 55 may process the stored signals to generate an image of each slice 40 of patient 22 and combine the images of the CT-slices to provide a 3D volume image of the patient's ROI.

[00068] In a variation of the embodiment, processor 55 may first enhance the preprocessed signals stored in memory 53, which signals represent a sinogram of the scan, and then, in order to further increase the quality, the processor may enhance again the image reconstructed from the enhanced

sinogram. Either or both of the described enhancements procedures may be carried-out by processor 55 according the flow diagram in Fig. 2 discussed below.

[00069] In an embodiment, to moderate risks to the health of patient 22 resulting from exposure of the patient to X-ray radiation from X-ray source 24, controller 50 controls CT-scanner 20 to acquire intensity data for a CT-image of the patient with a relatively low dose of radiation. The CT-image acquired using the low radiation dose may be a L-SNR image characterized by relatively low SNR. Processor 55 may operate to improve SNR of the L-SNR image to generate an image, also referred to as an E-Image, of patient 23 exhibiting enhanced SNR by processing images of CT-slices, such as exemplary CT-slices 40, of the patient using H-Patches stored in database 54.

[00070] In an embodiment, processor 55 may operate to provide an SNR enhanced CT-image of a ROI of patient 22 in accordance with a procedure illustrated in a flow diagram 100 shown in Fig. 2.

[00071] In a block 101 of the procedure, controller 50 controls CT-scanner 20 to acquire a low X-ray dose, L-SNR CT-image of patient 22. The image is assumed to be formed from a number S , of low SNR images, $L-PIM(s)$, $1 \leq s \leq S$, of CT-slices of the patient, each slice comprising pixels $LP(s)_p$ $1 \leq p \leq P(s)$. In a block 103 processor 55 (Fig. 1A) optionally determines for each pixel $LP(s)_p$ in an image $L-PIM(s)$ of an s -th CT-slice, an $L-Patch(s,p)$ comprising and optionally centered on pixel $LP(s)_p$, and comprising J pixels in image $L-PIM(s)$. Optionally, $L-Patch(s,p)$ is square. Fig. 3A schematically shows an example square $L-Patch(s,p)$ 60 outlined in a white border and comprising $J=9$ pixels defined for an $LP(s)_p$ pixel 61 marked by an asterisk in an image $L-PIM(s)$ 62 of an s -th CT-slice of patient 22. Optionally, in a block 105 the processor determines J different patches $O-Patch(s,p,j)$, $1 \leq j \leq J$, in image $L-PIM(s)$ 62 that overlap $L-Patch(s,p)$ 60, each $O-Patch(s,p,j)$ comprising a different set of J pixels from image $L-PIM(s)$. The pixels in a given overlapping $O-Patch(s,p,j)$ may be referred to as pixels $LOP(s,p,j)_k$, $1 \leq k \leq J$. Figs. 3B-3J schematically show the $J = 9$ overlapping patches $O-Patch(s,p,j)$, in $L-PIM(s)$ 62 defined for $L-Patch(s,p)$ 60 shown in Fig. 3A. Each overlapping patch $O-Patch(s,p,j)$ is bordered by a dashed white border 63, and comprises a different set of $J = 9$ pixels from CT-slice image $L-PIM(s)$ 62, one of which pixels is coincident with pixel 61 indicated by the asterisk.

[00072] Optionally, in a block 107, processor 50 identifies for each $O-Patch(s,p,j)$ 63 a high SNR patch $H-Patch(s,p,j)$ in H-SNR database 54 (Fig. 1A) having a same number of pixels and same

shape as O-Patch(s,p,j) that exhibits a relatively high degree of similarity with the O-Patch(s,p,j). In an embodiment the identified H-patch(s,p,j) may be an approximate nearest neighbor (ANN) to the O-Patch(s,p,j). An approximate nearest neighbor may be determined using any of various nearest neighbor search algorithms and may for example be determined using a randomized kd-trees algorithm such as implemented in the Fast Library for ANN (FLANN) for a Euclidean norm. Alternatively, a high SNR patch for a given O-Patch(s,p,j) may be generated by a regression neural network trained to generate a high SNR patch when fed at its input with a low SNR patch. For this purpose, it is necessary to have a training set consisting of corresponding low and high SNR patch pairs. Said pairs of patches can be obtained using an ANN algorithm to associate between patches from a low SNR database to patches of a high SNR database. Alternatively, the pairs can be created by adding synthetic noise corresponding to a given probability distribution function depending on the considered imaging modality (for example, Rician noise for MRI, Gaussian and Poisson noise for CT). In a block 109, processor 55 determines an enhanced value $ELP(s)_p$ for each pixel $LP(s)_p$ as a function of pixel values of pixels in the approximate nearest neighbor high SNR H-Patches(s,p,j), identified for the overlapping patches, O-Patches(s,p,j), $1 \leq j \leq J$, associated with $LP(s)_p$. In symbols $ELP(s)_p = F(H-Patch(s,p,j) \forall j: 1 \leq j \leq J)$.

[00073] Let the pixels in a j-th approximate nearest neighbor H-Patch(s,p,j) identified for an O-Patch(s,p,j) be represented by $HNN(s,p,j)_m$, $1 \leq m \leq J$ and its value by $Val(HNN'(s,p,j)_m)$. Let a pixel $HNN(s,p,j)_m$ for which $m = m^*(j)$ be a pixel, hereinafter also referred to as a H-SNR coincident pixel, in H-Patch(s,p,j) that is homologous with a pixel $LOP(s,p,j)_k$ in overlapping patch O-PATCH(s,p,j) that is coincident with pixel $LP(s)_p$ in L-PIM(s). $ELP(s)_p$ may optionally be determined in accordance with an expression $ELP(s)_p = F(H-Patch(s,p,j)) = (1/J) \sum_1^J Val(HNN(s,p,j)_{m^*(j)})$. A similar way to express the enhanced value for the pixel is $ELP(s)_p = \hat{p}_j = \frac{1}{P_s^2} \sum_{i=1}^{P_s^2} \hat{P}_i$ as for $\hat{P}_i \in (NN_{p_j})$ already given in the summary.

[00074] In an embodiment, the enhanced pixel $ELP(s)_p$ is determined as a function of the $HNN(j)_{m^*(j)}$ weighted by a measure of similarity between the L-PATCH(s,p) determined for $LP(s)_p$ and H-PATCH(j) to which pixel $HNN(j)_{m^*(j)}$ belongs. If $D(s,p,j)$ represents a measure of similarity between L-PATCH(s,p) and H-PATCH(j) then $ELP(s)_p$ may be determined in accordance with an expression,

$$\begin{aligned} \text{ELP}(s)_p &= F(\text{Val}(\text{HNN}(s,p,j)_{m^*(j)})) \\ &= [\sum_1^J \text{Val}(\text{HNN}(j)_{m^*(j)}) \exp(D(s, p, j)/h^2)] / \sum_1^J \exp(D(s, p, j)/h^2), \end{aligned}$$

where $h = J\gamma$ and γ is a constant. The Similarity function D can alternatively be replaced by a Distance function D' for which $D' = Q - D$, where Q is a positive constant number. In that case, a similar formulation for $\text{ELP}(s)_p$ can be given by

$$\text{ELP}(s)_p = \hat{p}_j = \frac{\sum_{i=1}^{P_s^2} \exp\left(-\frac{D(P_j, \hat{P}_i)}{h^2}\right) \hat{P}_{ij}}{\sum_{i=1}^{P_s^2} \exp\left(-\frac{D(P_j, \hat{P}_i)}{h^2}\right)}, \hat{P}_i \in (NN_{p_j}), \text{ as already given in the}$$

summary.

[00075] In a block 111 processor 55 uses the enhanced pixel values $\text{ELP}(s)_p$ determined for each CT-slice image L-PIM(s) to provide a CT-slice image EL-PIM(s) having enhanced SNR. The processor uses the CT-slice images EL-PIM(s) for all the S CT-slices, optionally in a block 113, to provide an E-SNR CT-image of patient 22 having an SNR that is enhanced relative to the SNR of the originally acquired L-SNR CT-image of patient 22.

[00076] It is noted that the above description of Figs. 1A-3 describes embodiments of the disclosure with reference to processing CT-slices acquired by CT-scanners, however, as noted above practice of an embodiment of the disclosure is not limited to CT-scanners and CT-slices. For example, an embodiment of the disclosure may be configured to process sinogram images acquired by a CT-scanner prior to the sinograms being processed to provide images of CT-slices of a patient. For example, H-SNR database 54 may comprise high SNR sinograms and/or sinogram H-Patches extracted from high SNR sinograms. Processor 55 may process low SNR sinograms of CT-slices of patient 22 acquired by CT-scanner 20 using sinogram H-Patches in a procedure similar to procedure 100 to provide high SNR sinograms for patient 22. The high SNR sinograms may then be processed to provide a picture CT-image of patient 22 having an SNR that is enhanced relative to an SNR of a CT-image of the patient that might have been provided using the L-SNR sinograms. And systems and methods in accordance with embodiments of the disclosure may be configured to enhance for example, low-SNR satellite images, subsurface Earth images acquired for example using seismic tomography, or ultrasound images of the human body or of inanimate bodies.

[00077] In the description and claims of the present application, each of the verbs, “comprise” “include” and “have”, and conjugates thereof, are used to indicate that the object or objects of

the verb are not necessarily a complete listing of components, elements or parts of the subject or subjects of the verb.

[00078] Descriptions of embodiments of the disclosure in the present application are provided by way of example and are not intended to limit the scope of the disclosure. The described embodiments comprise different features, not all of which are required in all embodiments. Some embodiments utilize only some of the features or possible combinations of the features. Variations of embodiments of the disclosure that are described, and embodiments comprising different combinations of features noted in the described embodiments, will occur to persons of the art.

CLAIMS

1. A medical imaging system, comprising:
 - an imager configured to provide a first medical image of a region of interest (ROI) of a patient, the medical image characterized by a first signal to noise ratio (SNR);
 - a database comprising image patches from at least one second image comprising an image of at least a portion of the ROI from another patient and characterized by a second SNR higher than the first SNR; and
 - a processor configured to:
 - determine for a given pixel in the first image a plurality of different first image patches in the first image, each having a pixel that is coincident with the given pixel;
 - identify for each first image patch an approximate nearest neighbor (ANN) image patch in the database;
 - determine an enhanced pixel value for the given pixel having an enhanced SNR greater than the first SNR responsive to pixel values of pixels in the identified ANN patches; and
 - use the determined pixel value to generate a second medical image of the ROI having an enhanced SNR greater than the first SNR.
2. The medical imaging system, according to claim 1 wherein the different first image patches comprise a same number of pixels.
3. The medical imaging system, according to claim 1 or claim 2 wherein the different first image patches have a same shape.
4. The medical imaging system, according to claim 3 wherein the first image patches are square.
5. The medical imaging system, according to any of the preceding claims wherein the enhanced pixel value is an average of pixel values of pixels in the ANN patches that are homologous with the pixels in the first image patches that are coincident with the given pixel.

6. The medical imaging system, according to claim 5 wherein the average is a weighted average.
7. The medical imaging system according to claim 6 wherein a pixel value of the pixel in the ANN patch that is homologous with the pixel in the first image patch associated with the ANN patch that is coincident with the given pixel is weighted by a measure of similarity between the ANN patch and a first image patch centered on the given first image pixel, computed for their overlapping pixels.
8. The medical imaging system according to claim 6 wherein a pixel value of the pixel in the ANN patch that is homologous with the pixel in the first image patch associated with the ANN patch that is coincident with the given pixel is weighted by a measure of similarity between the ANN patch and the associated first image patch.
9. The medical imaging system, according to any of the preceding claims wherein the database is cloud based.
10. The medical imaging system, according to any of claims 1-9 and comprising at least one communications interface that enables the imager to communicate with the database via a communications network.
11. The medical imaging system, according to claim 10 wherein the communications interface comprises a WiFi interface.
12. The medical imaging system, according to claim 10 or claim 11 wherein the communications interface comprises a Bluetooth interface.
13. The medical imaging system, according to any of claims 10 - 12 wherein the communications interface comprise a mobile communications network interface.
14. The medical imaging system, according to any of the preceding claims wherein the imager comprises a CT-scanner.

15. The medical imaging system, according to claim any of the preceding claims wherein the imager comprises an MRI scanner.
16. The medical imaging system, according to any of the preceding claims wherein the medical image comprises a picture image.
17. The medical imaging system, according to any of the preceding claims wherein the medical image comprises a sinogram image.
18. The medical imaging system, according to any of the preceding claims wherein the imager comprises at least one device suitable for one of the following: x-ray radiography, mammography, fluoroscopy, angiography, ultra-sound imaging, positron emission tomography (PET), computed tomography (CT), magnetic resonance imaging (MRI) or any combination thereof.
19. A method for providing a Locally-Consistent enhancement of a Low-Quality image (L-image) of an ROI to provide an Enhanced Image (E-image) of the ROI, the method comprising:
- (i) selecting a pixel p_j of the L-image to be enhanced;
 - (ii) defining a patch (L-patch) in the L-image, having P_N pixels and comprising pixel p_j ;
 - (iii) defining P_N O-patches that have the same size as the L-patch, contain pixel p_j and overlap at least a portion of the L-patch;
 - (iv) for each O-patch, returning from a relevant high-quality source (H-source), a high quality patch (H-patch) that satisfies a desired similarity criterion;
 - (v) computing an enhanced pixel value (EPV) for p_j , based on a function $F(\cdot)$ of the H-patches; and
 - (vi) replacing the pixel value of p_j with the computed EPV;
20. The method according to claim 19 and comprising repeating (i)-(vi).
21. The method according to claim 19 or claim 20 wherein the pixels and patches are bidimensional, or the pixels and patches are tri-dimensionals.

22. The method, according to any of claims 19-21 wherein a patch is square or rectangular.
23. The method according to any one of claims 19 - 22 wherein the given pixel p_j is a central pixel of the L-patch.
24. The method according to any one of claims 19 - 23 wherein the E-image is a de-noised image.
25. The method according to any one of claims 19 - 24 and comprising attenuating at least one image artifact in the L-image.
26. The method according to claim 25 wherein the at least one image artifact comprise a streak artifact and/or a blooming artifact.
27. The method according to any one of claims 19 - 26 wherein the pixel value comprises a real and/or complex number.
28. The method according to any one of claims 19 - 27 wherein the L-image is an image defined in an N-dimensional space, where N is an integer greater than or equal to 1.
29. The method according to claim 28, wherein at least one of the dimensions of the space is a time dimension.
30. The method according to any of claims 19-27 wherein the L-image is a CT, MRI, PET, or SPECT (single positron emission computed tomography) image, portion thereof, or data acquired therefore.
31. The method according to any one of claims 19 - 29 wherein the L-image is a visual representation of a set of data.
32. The method according to any one of claims 19 - 31 wherein the ROI comprises a region of an animal or human body.

33. The method according to any one of claims 19 - 32 wherein the ROI comprises a region of an inanimate body.

34. The method according to claim 33 wherein the ROI comprises a region of the surface of the earth and/or a subservice region of the earth.

35. The method according to any one of claims 19 - 34 wherein the H-patches and L-images are acquired from different imaging systems.

36. The method according to any one of claims 19 - 35 wherein $F(\cdot)$ returns an enhanced pixel value $EPV = \hat{p}_j$ for the given pixel p_j that is computed as a function of H-patches belonging to a set $\{NNp_j\}$ of nearest neighbor H-patches, $\hat{P}_i, 1 \leq i \leq P_N$, where P_N is a number of pixels in the L-patch.

37. The method according to claim 35 wherein function (\cdot) returns an average value of pixels from the H-patches that are homologous with a pixel in an O-patch coincident with the given pixel, in symbols

$$\hat{p}_j = F(\cdot) = \frac{1}{P_N} \sum_{i=1}^{P_N} \hat{P}_i \text{ for } \hat{P}_i \in \{NNp_j\}.$$

38. The method according to claim 35 wherein function $F(\cdot)$ returns a sum of $\hat{P}_i, i = 1 \dots P_N$ weighted by a distance measure between the overlapping pixels of \hat{P}_i and the original L-patch defined for the given pixel p_j , formalized as follows:

$$\hat{p}_j = \frac{\sum_{i=1}^{P_N} \exp\left(-\frac{D(p_j, \hat{P}_i)}{h^2}\right) \hat{P}_i}{\sum_{i=1}^{P_N} \exp\left(-\frac{D(p_j, \hat{P}_i)}{h^2}\right)}, \hat{P}_i \in \{NNp_j\}.$$

39. The method according to any one of claims 19-36 wherein function $F(\cdot)$ is a neural network that trained to map H-patches, corresponding to the O-patches containing pixel p_j , onto an enhanced value $EPV = \hat{p}_j$ for pixel p_j , .

40. The method according to any one of claims 19-39 wherein the L-images are CT-images acquired at relatively low X-ray radiation intensities relative to radiation intensities at which the H-patches are acquired.

41. The method according to any one of claims 19- 40 wherein the L-images are MRI-images acquired at relatively low scanning times relative to scanning times at which the H-patches are acquired.

42. A system for providing an Enhanced Image (E-image) based on a Locally-Consistent enhancement of a Low-Quality image (L-image) the system comprising:

- (i) an E-processor (402) having enhancement operation elements (410), that include set of instructions executable to implement a trained neural network (406);
- (ii) a H-database (403) and an L-database (404);
- (iii) a PACS (Picture Archiving and Communication System) (405) connected through DICOM (411) protocol to E-processor (402), H-source (403) and an L-database (404);
- (iv) a medical imaging modality (401) connected to the E-processor (402);
- (v) a radiologic workstation (407) communicating with the PACS system (405), for the retrieval of the E-images and their visualization;
- (vi) a display (408) ;and
- (vii) a human-machine interface (HMI) (409).

43. The system according to claim 42 and comprising at least one or any combination of more than one of a CT scanner, MRI scanner, PET scanner, and/or SPECT scanner.

44. The system according to any one of claims 42 or 43 wherein at least a portion of the system is cloud based.

45. The system according to any one of claims 42-44 wherein the E-processor is configured to enhance the L-image in accordance with any of claims 19-41.

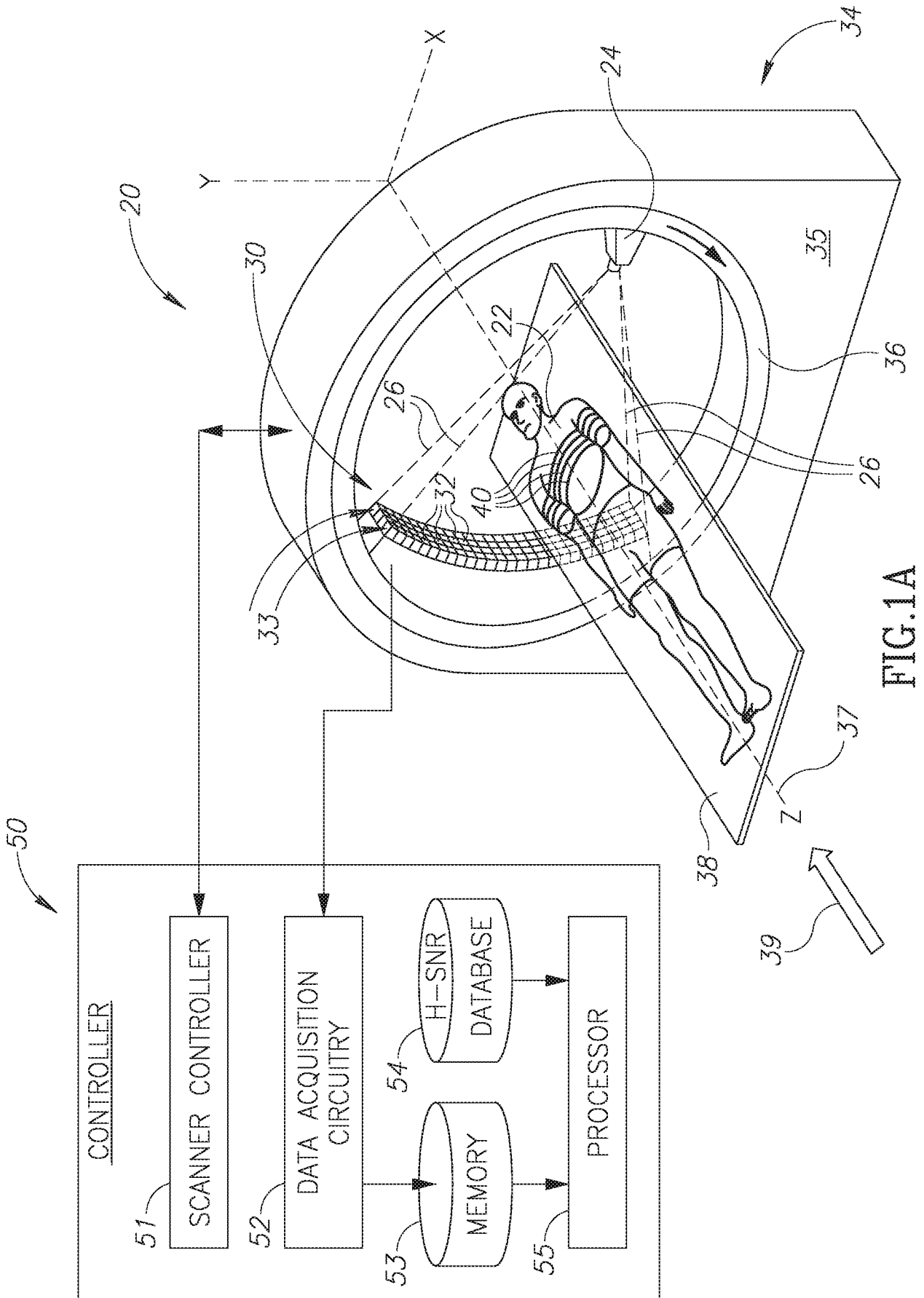

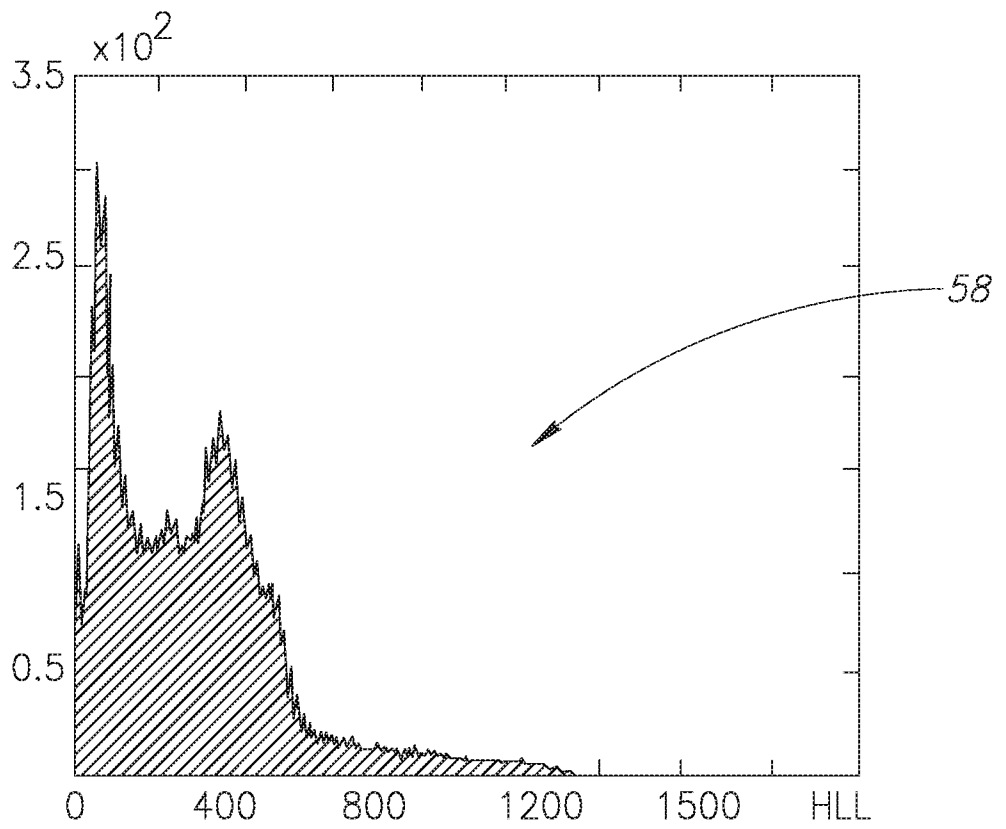
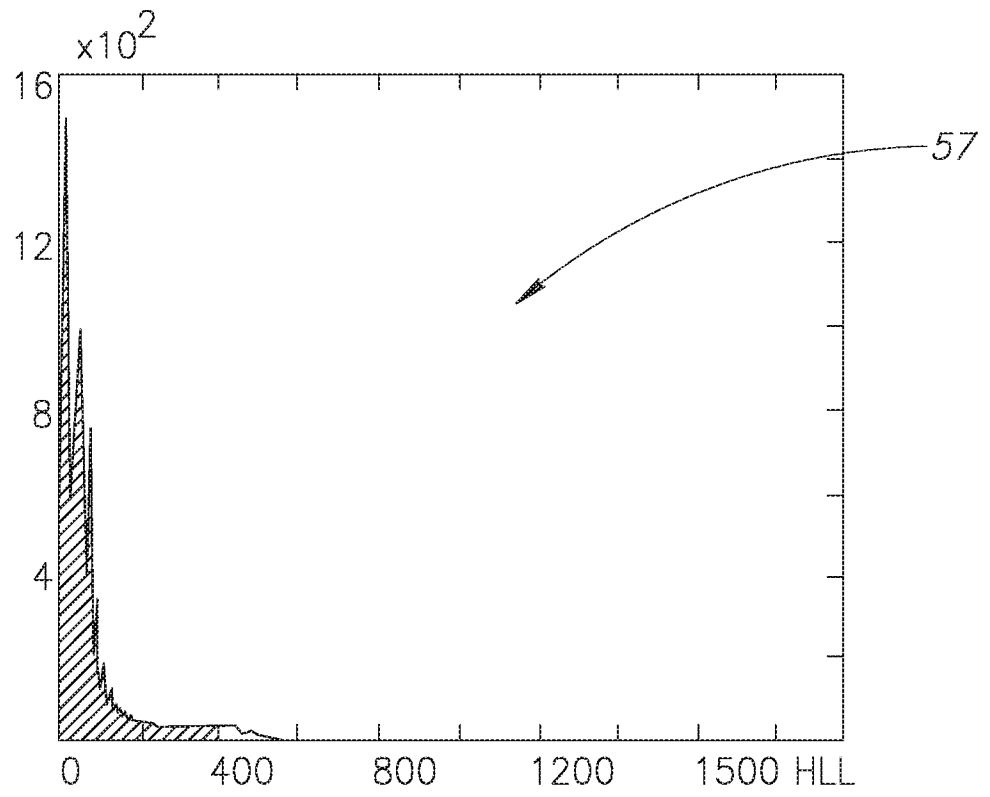

FIG.1B

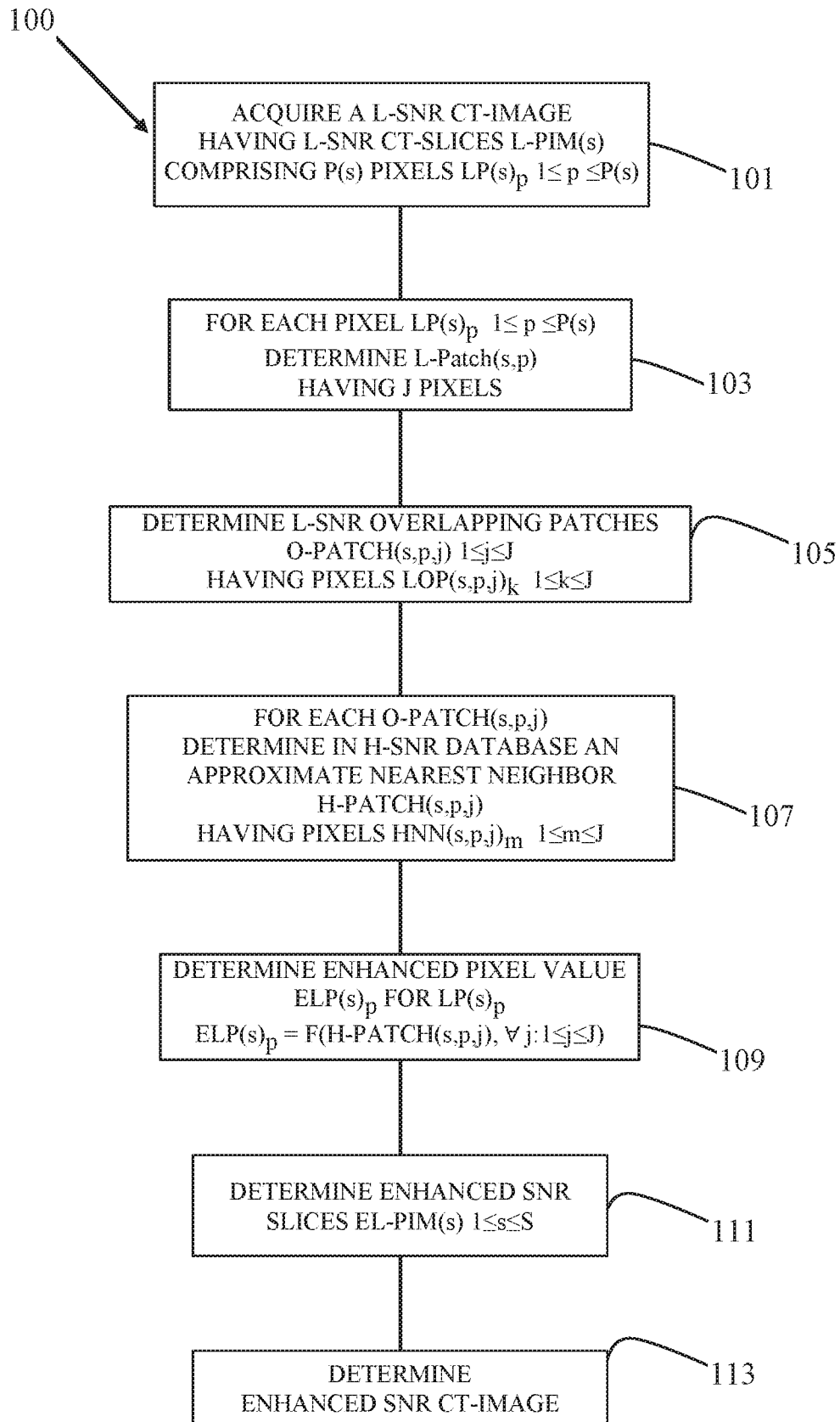

FIG 2

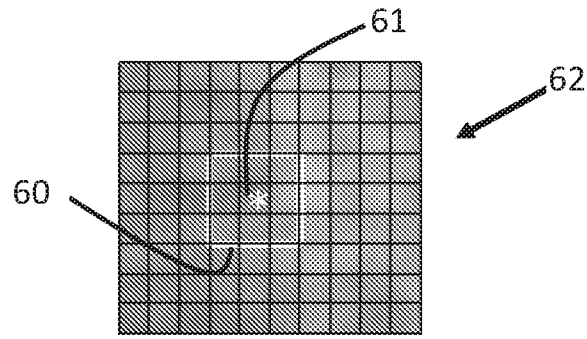

FIG 3A

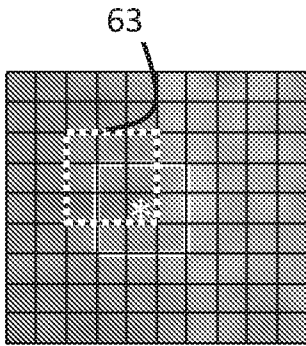

FIG 3B

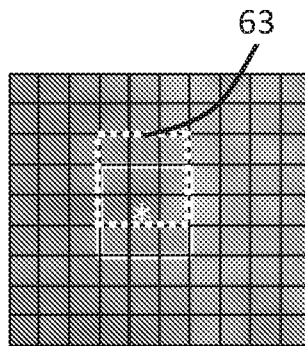

FIG 3C

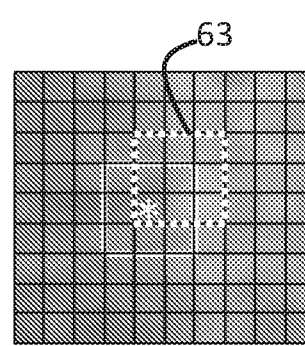

FIG 3D

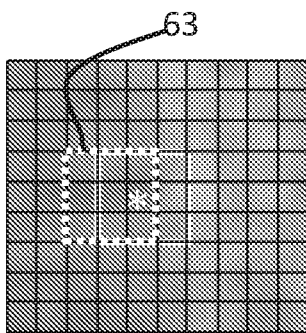

FIG 3E

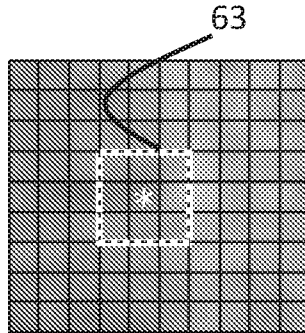

FIG 3F

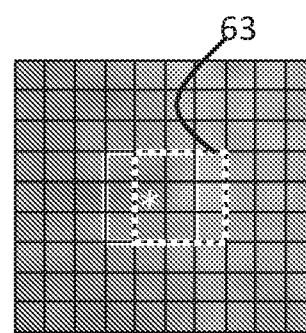

FIG 3G

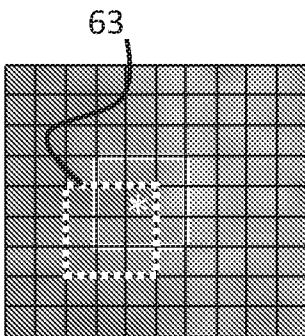

FIG 3H

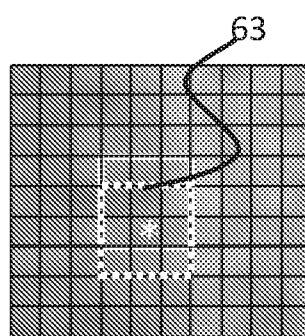

FIG 3I

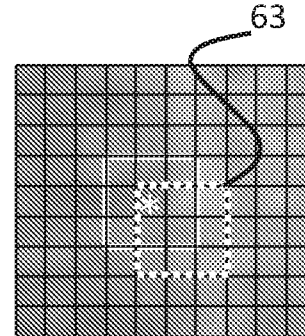

FIG 3J

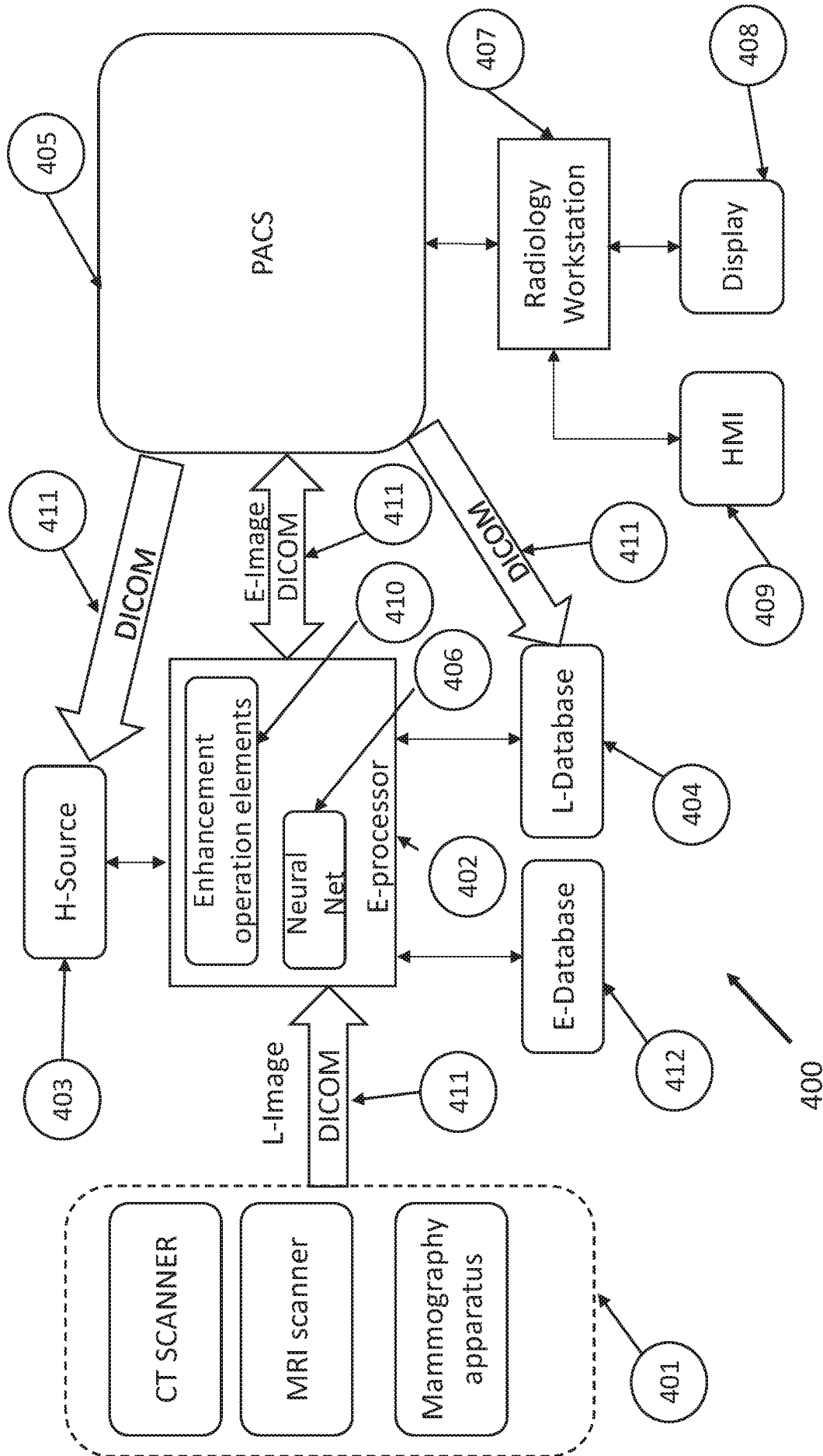

Fig. 4

INTERNATIONAL SEARCH REPORT

International application No.

PCT/IL2017/050497

A. CLASSIFICATION OF SUBJECT MATTER IPC (2017.01) G06T 5/00, G06K 9/36		
According to International Patent Classification (IPC) or to both national classification and IPC		
B. FIELDS SEARCHED		
Minimum documentation searched (classification system followed by classification symbols) IPC (2017.01) G06T 5/00, G06K 9/36		
Documentation searched other than minimum documentation to the extent that such documents are included in the fields searched		
Electronic data base consulted during the international search (name of data base and, where practicable, search terms used) Databases consulted: THOMSON INNOVATION, Esp@cenet, Google Patents Search terms used: Match*, overlap*, patch*, segment*, imag*, similar*, nearest, common*, pixel*, MRI, CT, X*ray, average, weight		
C. DOCUMENTS CONSIDERED TO BE RELEVANT		
Category*	Citation of document, with indication, where appropriate, of the relevant passages	Relevant to claim No.
X	US 2013071040 A1 Jin et al. 21 Mar 2013 (2013/03/21) (The whole document especially Figs. 1, 2, 4, 5, 7).	1-45
A	US 2004218834 A1 MICROSOFT CORPORATION, REDMON, WA (US) 04 Nov 2004 (2004/11/04) (The whole document especially abstract, Figs. 1-3, 6, 7).	1-45
A	US 2015104116 A1 Salvador et al. 02 Sep 2014 (2014/09/02) (Figs. 9-12).	1-45
A	US 2014254882 A1 ADOBE SYSTEMS INCORPORATEDs San Jose, CA (Us) 11 Sep 2014 (2014/09/11) (Figs. 1, 6, 7).	1-45
A	US 9123140 B1 Pixelworks, Inc. Poetland OR (US) 01 Sep 2015 (2015/09/01) (Abstract, Figs. 5, 11).	1-45
<input checked="" type="checkbox"/> Further documents are listed in the continuation of Box C. <input checked="" type="checkbox"/> See patent family annex.		
* Special categories of cited documents: “A” document defining the general state of the art which is not considered to be of particular relevance “E” earlier application or patent but published on or after the international filing date “L” document which may throw doubts on priority claim(s) or which is cited to establish the publication date of another citation or other special reason (as specified) “O” document referring to an oral disclosure, use, exhibition or other means “P” document published prior to the international filing date but later than the priority date claimed “T” later document published after the international filing date or priority date and not in conflict with the application but cited to understand the principle or theory underlying the invention “X” document of particular relevance; the claimed invention cannot be considered novel or cannot be considered to involve an inventive step when the document is taken alone “Y” document of particular relevance; the claimed invention cannot be considered to involve an inventive step when the document is combined with one or more other such documents, such combination being obvious to a person skilled in the art “&” document member of the same patent family		
Date of the actual completion of the international search 26 Sep 2017		Date of mailing of the international search report 28 Sep 2017
Name and mailing address of the ISA: Israel Patent Office Technology Park, Bldg.5, Malcha, Jerusalem, 9695101, Israel Facsimile No. 972-2-5651616		Authorized officer NIMER Emad Telephone No. 972-2-5657801

INTERNATIONAL SEARCH REPORT

International application No.

PCT/IL2017/050497

C (Continuation). DOCUMENTS CONSIDERED TO BE RELEVANT		
Category*	Citation of document, with indication, where appropriate, of the relevant passages	Relevant to claim No.
A	US 2012328210 A1 YISSUM RESEARCH DEVELOPMENT COMPANY OF THE HEBREW UNIVERSITY OF JERUSALEM Jerusalem (IL) 27 Dec 2012 (2012/12/27) (Fig. 11).	1-45
A	US 9317903 B1 Pixelworks, Inc. Poetland OR (US) 19 Apr 2016 (2016/04/19) (Abstract, Figs. 4, 13, 15).	1-45
A	US 2013034299 A1 Lin et al. 07 Feb 2013 (2013/02/07) (Abstract, Figs. 1, 9).	1-45
A	US 8396325 B1 Google Inc., Mountain View, CA (US) 12 Mar 2013 (2013/03/12) (Abstract. Figs. 1-4).	1-45

INTERNATIONAL SEARCH REPORT
Information on patent family members

International application No. PCT/IL2017/050497
--

Patent document cited search report	Publication date	Patent family member(s)	Publication Date
US 2013071040 A1	21 Mar 2013	US 2013071040 A1	21 Mar 2013
		US 9087390 B2	21 Jul 2015
		US 2013071041 A1	21 Mar 2013
		US 8917948 B2	23 Dec 2014
US 2004218834 A1	04 Nov 2004	US 2004218834 A1	04 Nov 2004
		US 7218796 B2	15 May 2007
US 2015104116 A1	02 Sep 2014	US 2015104116 A1	16 Apr 2015
		US 9258518 B2	09 Feb 2016
		CN 104160422 A	19 Nov 2014
		EP 2823461 A1	14 Jan 2015
		JP 2015515179 A	21 May 2015
		JP 6085620 B2	22 Feb 2017
		KR 20140135968 A	27 Nov 2014
		WO 2013131929 A1	12 Sep 2013
US 2014254882 A1	11 Sep 2014	US 2014254882 A1	11 Sep 2014
		US 9129399 B2	08 Sep 2015
US 9123140 B1	01 Sep 2015	US 9123140 B1	01 Sep 2015
US 2012328210 A1	27 Dec 2012	US 2012328210 A1	27 Dec 2012
		US 8867858 B2	21 Oct 2014
		CN 102770887 A	07 Nov 2012
		EP 2529353 A1	05 Dec 2012
		JP 2013518336 A	20 May 2013
		KR 20130001213 A	03 Jan 2013
		WO 2011092696 A1	04 Aug 2011
US 9317903 B1	19 Apr 2016	US 9317903 B1	19 Apr 2016

INTERNATIONAL SEARCH REPORT
Information on patent family members

International application No.
PCT/IL2017/050497

Patent document cited search report	Publication date	Patent family member(s)	Publication Date
US 2013034299 A1	07 Feb 2013	US 2013034299 A1	07 Feb 2013
		US 8687923 B2	01 Apr 2014
		US 2013034313 A1	07 Feb 2013
		US 8655109 B2	18 Feb 2014
		US 2013034311 A1	07 Feb 2013
		US 8731337 B2	20 May 2014
US 8396325 B1	12 Mar 2013	US 8396325 B1	12 Mar 2013
		US 8571349 B1	29 Oct 2013