



- (51) International Patent Classification:
A41G 5/00 (2006.01) A41G 3/00 (2006.01)
- (21) International Application Number:
PCT/US2016/052237
- (22) International Filing Date:
16 September 2016 (16.09.2016)
- (25) Filing Language: English
- (26) Publication Language: English
- (30) Priority Data:
14/856,259 16 September 2015 (16.09.2015) US
- (63) Related by continuation (CON) or continuation-in-part (CIP) to earlier application:
US 14/856,259 (CON)
Filed on 16 September 2015 (16.09.2015)
- (72) Inventor; and
- (71) Applicant : DOUBT, Ruxton, C. [US/US]; 13851 South-east 224th Street, Kent, Washington 98042 (US).
- (74) Agents: HEFTER, Karl, A. et al.; Seed Intellectual Property Law Group PLLC, Suite 5400, 701 Fifth Avenue, Seattle, Washington 98104-7064 (US).

- (81) Designated States (unless otherwise indicated, for every kind of national protection available): AE, AG, AL, AM, AO, AT, AU, AZ, BA, BB, BG, BH, BN, BR, BW, BY, BZ, CA, CH, CL, CN, CO, CR, CU, CZ, DE, DK, DM, DO, DZ, EC, EE, EG, ES, FI, GB, GD, GE, GH, GM, GT, HN, HR, HU, ID, IL, IN, IR, IS, JP, KE, KG, KN, KP, KR, KW, KZ, LA, LC, LK, LR, LS, LU, LY, MA, MD, ME, MG, MK, MN, MW, MX, MY, MZ, NA, NG, NI, NO, NZ, OM, PA, PE, PG, PH, PL, PT, QA, RO, RS, RU, RW, SA, SC, SD, SE, SG, SK, SL, SM, ST, SV, SY, TH, TJ, TM, TN, TR, TT, TZ, UA, UG, US, UZ, VC, VN, ZA, ZM, ZW.
- (84) Designated States (unless otherwise indicated, for every kind of regional protection available): ARIPO (BW, GH, GM, KE, LR, LS, MW, MZ, NA, RW, SD, SL, ST, SZ, TZ, UG, ZM, ZW), Eurasian (AM, AZ, BY, KG, KZ, RU, TJ, TM), European (AL, AT, BE, BG, CH, CY, CZ, DE, DK, EE, ES, FI, FR, GB, GR, HR, HU, IE, IS, IT, LT, LU, LV, MC, MK, MT, NL, NO, PL, PT, RO, RS, SE, SI, SK, SM, TR), OAPI (BF, BJ, CF, CG, CI, CM, GA, GN, GQ, GW, KM, ML, MR, NE, SN, TD, TG).

Published:
— with international search report (Art. 21(3))

(54) Title: SYSTEM AND METHOD FOR INCREASING HAIR VOLUME

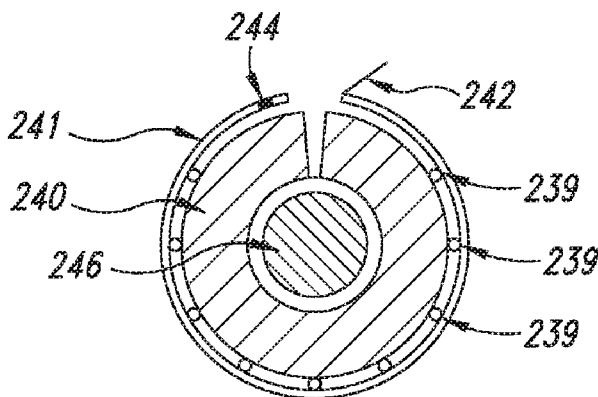

FIG. 24B

(57) Abstract: A system having a sleeve with a circumscribing sidewall formed of elastic, compliant material, the sleeve having an internal axial bore sized to have an inside diameter equal to or less than an outside diameter of a host hair to be received in the bore, the sidewall formed of thermoplastic resilient, compliant material, and at least one supplemental hair embedded in the sidewall or attached to the sidewall of the sleeve.

WO 2017/049152 A1

SYSTEM AND METHOD FOR INCREASING HAIR VOLUME

CROSS REFERENCE TO RELATED APPLICATION

This application claims the benefit under 35 U.S.C. § 119(e) to U.S. Non-Provisional Application No. 14/856,259 filed September 16, 2015, which application is
5 incorporated by reference herein in its entirety.

BACKGROUND

Technical Field

The present disclosure is directed to supplementing existing human hair and, more particularly, to adding volume by attachment of additional hair strands to a
10 host strand of hair.

Description of the Related Art

It is known that hair transplants only achieve a 30% to 50% increase in hair density. While an increase of 50% in hair density generally looks better, a lower density of hair improvement usually presents a thin head of hair. Ideally, the goal is to
15 obtain a thickening of 100% or more of existing hair.

Prior methods are problematic because of limitations on reusability. For example, adhesives have been used to glue or bond additional hair to an existing hair shaft. The difficulty with adhesives is that they are exposed to the elements, such as rain, the ocean, sweat, as well as chemicals from shampoo, which can break down the
20 adhesive. When the adhesive breaks down, the bond fails, resulting in hair loss.

Other methods and devices include the use of metal clamps. Such clamps require special tools to attach the clamp to the hair. In order to adjust and accommodate growing hair, the clamps must be unclamped and reclamped, resulting in tedious and expensive labor. Metal fatigue is also an issue with these types of clamps.
25 Moreover, the use of thousands of clamps in a head of hair may cause allergic reactions, and these clamps can be easily snagged or pulled with a comb or brush.

Another approach has been to use thermal plastic tubes that are shrunk onto the hair with the application of heat. Such heat-shrunk tubes are difficult to adjust because they require reheating, which can be damaging to existing hair and the scalp,
30 and such tubes are usually not able to be reheated and reapplied.

In general, existing methods and devices are one-time applications only. The practicality of attempting to adjust these existing hair supplementation devices while attached to the existing hair makes them unusable for all intents and purposes.

BRIEF SUMMARY

5 The present disclosure is directed to a system and method for supplementing existing hair, which can include thickening of the hair and adding hair extensions to host hair to increase volume, such as density or length or both.

 In accordance with one aspect of the disclosure, the system includes a sleeve or thin tube formed from a sidewall having an internal axial bore. Ideally, the
10 sidewall is formed of thermoplastic resilient or compliant material that is unaffected by UV and saltwater exposure. The system also includes at least one supplemental hair attached to the sidewall of the sleeve or tube. Ideally, the supplemental hair is a user's own hair that has fallen out or been cut. The internal axial bore of the tube is sized to have a diameter equal to or less than a diameter of a host hair to enable the tube to
15 elastically grip the host hair when the tube is placed over the host hair.

 In accordance with one aspect of the present disclosure, a system is provided to increase hair density of existing hair, the system including a sleeve having a cylindrical body with an interior surface and opposing exterior surface, the body further including first and second ends and a longitudinal slit formed in the body and entire
20 length of the sleeve from the first end to the second end, the slit having a width defined by a distance between a first sidewall and a second sidewall of the sleeve body; a plurality of hair strands embedded in the sleeve body or attached to the exterior surface of the body; and an attachment system configured to attach the sleeve to one hair shaft of the existing hair.

25 In accordance with a further aspect of the present disclosure, a method of increasing hair density of existing hair is provided, the method including (a) attaching to a shaft of hair of the existing hair a sleeve having a cylindrical body with an interior surface and opposing exterior surface and a plurality of hair strands embedded in the body or attached to the exterior surface of the body, the body further including first and
30 second ends and a longitudinal slit formed in the body an entire length of the sleeve from the first end to the second end, the slit having a width defined by a distance between a first sidewall and a second sidewall of the sleeve body; and (b) securing the sleeve to the shaft of hair to enable the sleeve to move in one direction on the shaft of hair and resist movement in an opposite direction on the shaft of hair.

In accordance with still yet a further aspect of the present disclosure, a system is provided that includes a sleeve having a circumscribing sidewall formed of elastic, compliant material, the sleeve having an internal axial bore sized to have a diameter equal to or less than a diameter of a host hair to be received in the bore, the
5 sidewall formed of thermoplastic resilient, compliant material; and at least one supplemental hair attached to the sidewall of the sleeve.

BRIEF DESCRIPTION OF THE SEVERAL VIEWS OF THE DRAWINGS

The foregoing and other features and advantages of the present disclosure will be more readily appreciated as the same become better understood from
10 the following detailed description when taken in conjunction with the accompanying drawings, wherein:

Figure 1 is a side view of an insulated cable prepared for attachment of supplemental hair in accordance with the present disclosure;

Figure 2 is a cross-sectional view of the tube of the present disclosure
15 having the supplemental hair clamped to an exterior surface in accordance with the present disclosure;

Figure 3 is a cross-sectional side view of the supplemental hairs embedded in the sidewall of the tube in accordance with the present disclosure;

Figure 4 is a cross-sectional view of the supplemental hair partially
20 embedded in the sidewall of the tube in accordance with the present disclosure, with a host hair inserted in the internal axial bore;

Figure 5 is a side cross-sectional view of the supplemental hair embedded in the tube when mounted to the cable;

Figure 6 is a side cross-sectional view of the host hair slid into the
25 deployed wires;

Figure 7 is a side cross-sectional view of the tube received over the host hair in accordance with the present disclosure;

Figure 8 is an isometric view of a sleeve formed in accordance with an alternative aspect of the present disclosure;

Figure 9 is a partial view in cross section of the sleeve of Figure 8
30 showing an internal construction thereof;

Figure 10 is a cross-sectional view of the sleeve of Figure 8 attached to a host hair with a clamp in accordance with the present disclosure;

Figure 11 is an enlarged view of the sleeve shown in Figure 10;

Figure 12 is a cross-sectional view of a further aspect of the present disclosure in which the sleeve of Figure 8 is reconfigured to incorporate the clamping mechanism of the clamp of Figure 10 only at the ends thereof for attachment to a host hair;

5 Figure 13 is an isometric view of an initial step of a method in accordance with the present disclosure;

Figure 14 illustrates a supplemental hair inserted into a pocket at the end of a needle in accordance with the present disclosure;

10 Figure 15 is an isometric view of the needle and supplemental hair of Figure 14 positioned for installation on the sheet of thermoplastic material;

Figure 16 is an isometric view of the formation of the sleeve from the sheet of thermoplastic material in accordance with the present disclosure;

Figure 17 is an isometric view of a trough and cutting tool used to form the slit in the sleeve in accordance with the present disclosure;

15 Figure 18 is a top plan view of the sleeve with clamping members held in position over a host hair by pliers formed in accordance with the present disclosure;

Figure 19 is an isometric view of a large diameter sleeve formed in accordance with the present disclosure;

20 Figure 20 is an isometric view of an ultra-thin sleeve formed in accordance with the present disclosure;

Figure 21 is a side view of a belt having supplemental hairs attached to belt strands extending from the belt in accordance with the present disclosure;

Figure 22 is a side view of a belt having supplemental hairs extending along and attaching to the belt in accordance with the present disclosure;

25 Figure 23 is a side view of a belt having a tab and slit locking mechanism in accordance with the present disclosure;

Figure 24A and 24B are cross-sectional views of a sleeve and belt positioned around a host hair in accordance with the present disclosure;

30 Figure 25 is an isometric view of a plate with a v-groove for positioning a host hair in the sleeve in accordance with the present disclosure;

Figure 26 is a side cross-sectional view of the plate of Figure 25 accepting a host hair in a v-groove to position the host hair in the sleeve in accordance with the present disclosure;

35 Figure 27 is a front cross-sectional view of the plate accepting the host hair in the v-groove to position the host hair in the sleeve in accordance with the present disclosure;

Figure 28 is a side cross-sectional view of the plate with the host hair positioned in the sleeve in accordance with the present disclosure;

Figure 29 is a front cross-sectional view of the plate with the host hair positioned in the sleeve in accordance with the present disclosure;

5 Figure 30 is a side cross-sectional view of the removal of the host hair and sleeve from the plate with the sleeve clamped on the host hair in accordance with the present disclosure;

 Figure 31 is a front cross-sectional view of the removal of the host hair and sleeve from the plate with the sleeve clamped on the host hair in accordance with
10 the present disclosure; and

 Figures 32 and 33 are isometric views of a sleeve with an install-ledge in accordance with the present disclosure;

 Figures 34 and 35 are side views of a sleeve with an install-ledge in accordance with the present disclosure; and

15 Figure 36 is a front view of a sleeve with an install-ledge in accordance with the present disclosure.

DETAILED DESCRIPTION

 In the following description, certain specific details are set forth in order to provide a thorough understanding of various disclosed embodiments. However, one
20 skilled in the relevant art will recognize that embodiments may be practiced without one or more of these specific details, or with other methods, components, materials, etc. In other instances, well-known structures or components or both associated with hair care, including but not limited to hair lubricants, have not been shown or described in order to avoid unnecessarily obscuring descriptions of the embodiments.

25 Unless the context requires otherwise, throughout the specification and claims that follow, the word “comprise” and variations thereof, such as “comprises” and “comprising” are to be construed in an open inclusive sense, that is, as “including, but not limited to.” The foregoing applies equally to the words “including” and “having.”

 Reference throughout this description to “one embodiment” or “an
30 embodiment” means that a particular feature, structure, or characteristic described in connection with the embodiment is included in at least one embodiment. Thus, the appearance of the phrases “in one embodiment” or “in an embodiment” in various places throughout the specification are not necessarily all referring to the same embodiment. Furthermore, the particular features, structures, or characteristics may be
35 combined in any suitable manner in one or more embodiments.

The present disclosure is directed to a system and method of using an elastic sleeve (or tube) to attach several hairs (synthetic or real) to a host hair growing out of the scalp. In so doing the hair density (number of hairs per square inch on the scalp) will be increased, giving the prospective user the potential for a full head of hair.

5 In order to provide the installer of the sleeve with a product which provides this increase of hair density, several procedures are involved.

By “attach” and “attachment” of hair, the present disclosure is intended to embrace known means of connecting or coupling hair to a substrate, including without limitation embedding a portion of hair or synthetic hair into a substrate, as
10 described more fully below. Attachment can also include attaching the hair to the exterior surface of the substrate, such as with adhesive or fusion or by other well-known processes that will not be described herein. In addition, increasing volume includes thickening of the hair or lengthening of the hair or both.

Briefly, the system to increase the appearance of hair volume includes a
15 sleeve configured to engage the shaft of hair and to prevent sliding of the sleeve in a first longitudinal direction on the host hair while permitting sliding of the sleeve on the host hair in an opposite longitudinal direction, at least one supplemental hair extending from the sleeve, and a clamp structured to clamp the sleeve and the at least one supplemental hair to the host hair, the clamp structured to remain on the sleeve and to
20 enable the sleeve to slide in the first longitudinal direction on the host hair.

The sleeve can have a circumscribing sidewall formed of elastic, compliant material with an internal axial bore sized to have a diameter equal to or less than a diameter of a host hair to be received in the bore. The body has an interior surface with at least one edge configured to engage the shaft of hair and to prevent
25 sliding of the sleeve in a first longitudinal direction on the host hair while permitting sliding of the sleeve on the host hair in an opposite longitudinal direction.

In another implementation, the sleeve has a cylindrical body with an interior surface and opposing exterior surface, the body including first and second ends and a longitudinal slit formed in the body and an entire length of the sleeve from the
30 first end to the second end. The slit has a width defined by a distance between a first sidewall and a second sidewall of the sleeve body, and the interior surface of the body has at least one edge configured to engage the shaft of hair and permit sliding of the sleeve on the shaft of hair in a first direction and resist sliding of the sleeve on the shaft of hair in a direction opposite the first direction.

35 A method of increasing hair density of existing hair is also provided for use with the foregoing system. The method generally includes attaching to a shaft of

hair of the existing hair a sleeve having a cylindrical body with an interior surface and opposing exterior surface and a plurality of hair strands integrally embedded in the body, the body further including first and second ends and a longitudinal slit formed in the body and entire length of the sleeve from the first end to the second end, the slit
5 having a width defined by a distance between a first sidewall and a second sidewall of the sleeve body, the interior surface of the body having at least one edge configured to engage the shaft of hair and permitting sliding of the sleeve on the shaft of hair in an opposite direction; and securing the sleeve to the shaft of hair with a clamp to enable the sleeve to move in one direction on the shaft of hair and resist movement in an
10 opposite direction on the shaft of hair.

Turning next to the implementations illustrated in the figures, and referring initially to Figure 1, shown therein is a sleeve 10 mounted on a four-wire cable 12. Ideally, the sleeve 10 is constructed from OM3060 Thermoplastic available from PolyOne Corporation. This material is used as insulation over the cable 12 and is
15 available from Calmont Corporation. In other words, the insulated cable 12 uses the thermoplastic insulation from PolyOne Corporation. The insulation is used as an encasing for the four strands of preferably 54-gauge stainless steel wire, which are intertwined.

As shown in Figure 1, the cable is formed of four individual wires 14
20 that are exposed on each end of the sleeve 10. In other words, the insulated cable is partially stripped, leaving the sleeve 10, which is approximately 1/16" to 1/2" in length and ideally 1/4" in length. The sleeve 10 is situated between the exposed ends 16, 18 of the cable 12. Ideally each exposed end 16, 18 is about 1" in length.

At this stage, supplemental hairs, approximately 2 to 7 hairs, and more
25 preferably 3 to 6 hairs, are attached to the sleeve 10. The attachment may be either with adhesive or the hairs may be partially embedded or completely embedded into the thermoplastic sleeve 10.

If it is desired to embed the hairs into the sleeve 10, the sleeve should first be heated to soften the material. This can be done by running current through the
30 cable 12 to cause the wires 14 to heat up, transferring the heat to the sleeve 10, preferably only the amount of heat needed to sufficiently soften the thermoplastic sleeve 10 and allow the supplemental hairs to be pushed into it. Referring to Figure 2, shown therein is an end view of the cable 12 and the sleeve 10 having a plurality of supplemental hairs 20 positioned around the outside perimeter of the sleeve 10. A
35 clamp tool 22 is sized and shaped to encircle the sleeve 10 and press the hairs 20 into the softened sleeve 10. As shown in Figure 3, the hairs 20 are completely embedded in

a sidewall 24 of the sleeve 10. Alternatively, as shown in Figure 4, one or more of the supplemental hairs 20 can be partially embedded in the sidewall 24 of the sleeve 10. This is done by controlling the amount of compression exerted by the tool 22 on the hairs 20. Alternatively, the hairs can remain attached to the outside of the sidewall 24 of the sleeve 10 as shown in Figure 2.

Referring next to Figure 5, shown therein is the sleeve 10 having the supplemental hairs 20 embedded in the sidewall 24. In order to prepare the sleeve 10 for mounting on a host hair, the wires 14 on the first end 16 are spread apart to allow the host hair 26 (see Figure 6) to be inserted between the wire strands 14.

Ideally before the hairs 20 are immersed or embedded into the sleeve 10, they may be treated with a temporary adhesive or adhesion promoter, such as a silane. Also, before the supplemental hairs 20 are attached to the sleeve, the sleeve inside diameter is selected in accordance with the size of the host hair. Thus, the host hair is first measured to determine its diameter, and then a cable 12 with insulation is selected having an inside diameter of the sleeve 10 that is in the range of approximately 1/4 the outside diameter of the host hair up to and including the actual outside diameter of the hair.

It is to be understood that the wall thickness of the sleeve 10 may vary, but should be a sufficient thickness to enable complete immersion of the supplemental hairs 20. While the sleeve's outer circumference can be several times larger than the diameter of the supplemental hairs 20, it will not necessarily be visible. However, if visibility of the sleeve 10 is seen as an advantage, such as for decoration or highlighting, the supplemental hairs 20 that are attached or embedded into the sleeve 10 can be partially embedded such that upon close inspection, several hairs can be seen converging at the scalp at the same place. Because this convergence is surrounded by a substantial number of other similar convergences, it will become difficult to notice anything unusual.

In order to render the sleeve 10 ready for installation on the host hair 26, two additional preparation steps may be needed.

First, the wire cable 12 may need to be heated in order to enable the sleeve 10 to be dislodged from the wire cable 12. The sleeve should be able to slide freely so that the user or installer will be able to slide the sleeve with minimal effort off the wire cable 12.

Secondly, the wires on the first end 16 are separated as described above to form a receiving opening to capture the host hair 26.

The host hair 26 may need a stiffening agent applied to it so that it will remain sufficiently rigid to be guided into the mouth of the parted wires 14. After the host hair 26 is situated among the wires 14, the movement of the sleeve sliding down the wires 14 towards the first end 16 will cause the wires 14 to clamp down and
5 surround the host hair 26, thus holding the host hair 26 in place. Alternatively, a tool may be used to initially clamp the wires 14 around the host hair 26 until the sleeve is sufficiently slid towards the first end 16 to allow the clamping tool to be removed without risking the host hair 26 being pushed out from between the wires 14.

Although the inside diameter of the sleeve is in the range of
10 approximately 1/4 the outside diameter of the host hair 26 up to and including the actual outside diameter of the host hair 26, the elastic nature of the thermoplastic sleeve allows it to stretch over the wires 14 that surround the host hair 26 and to slide onto the shaft of the host hair 26. To facilitate sliding of the sleeve 10 onto the host hair 26, the host hair
15 host hair 26. Ideally the lubrication is applied after the host hair 26 is placed between the wires 14.

Once the sleeve 10 slides past the ends of the wires 14 and is on the host hair 26, the wires 14 are pulled away, leaving the sleeve about 1" past the end of the host hair 26. At this point, the sleeve 10 can be slid further down the host hair 26. This
20 is accomplished by holding the free end of the host hair 26 so that the hair is taut, such as with the fingers or an appropriate tool, while the sleeve is pushed down the shaft of the host hair 26 to meet the scalp. Once the sleeve 10 is in position, the vitamin E is removed from the host hair 26. As the host hair 26 grows out, adjustments in the location of the sleeve 10 along the host hair 26 will be needed. It is expected that this
25 may be needed every 6 to 8 weeks, coinciding with a haircut. The installed sleeves can be pushed back down the host hair 26 to touch the scalp. If needed, lubricant can be placed on the host hair 26 to facilitate sliding of the sleeve 10.

It should be noted that choosing different inside diameters of the sleeve 10 enables a user to select more or less gripping power onto the host hair. In addition,
30 thicker sidewalls 24 will provide more room for embedding of the supplemental hairs 20 therein, giving greater strength and more gripping power to the supplemental hairs 20. While a thicker sidewall 24 means a greater circumference, it also means that more supplemental hairs 20 can be attached thereto.

To comb out tangles, the host hair 26 can be held near the scalp, such as
35 with the fingers, so that all force exerted by a comb or brush goes against the one hand and avoids pulling the sleeve away from the scalp.

Reference is now made to Figures 8 and 9 in which is shown an alternative design of a sleeve 80 formed in accordance with the present disclosure for use in increasing hair density of existing hair. This alternative design is considered to be a preferred system and method of the present disclosure.

5 The sleeve has a cylindrically shaped body 82 with first and second ends 84, 86, respectively, and a longitudinal slit 88 formed in the body 82 that extends an entire length of the sleeve 80 from the first end 84 to the second end 86. The slit 88 has a width that is defined by a distance between a first sidewall 90 and a second sidewall 92 in the sleeve body 82. The sleeve body 82 also has an exterior surface 94 that is
10 substantially smooth, and an interior surface 96 that is also substantially smooth except for a plurality of angled cuts 98, described in more detail below.

 Extending from the first end 84 of the sleeve 80 are a plurality of hairs 100 that are embedded in the body 82 of the sleeve 80, as shown more clearly in the enlarged view of Figure 9 showing the cuts 98 on the interior surface 96 of the sleeve
15 body 82. As can be seen, the cuts 98 have a cross-sectional V-shape that is angled in one direction, in this case towards the second end 86. When the sleeve 80 is wrapped around and squeezed onto a host hair, the edges 102 of the cut 98 will bite into the host hair a slight distance and resist movement of the sleeve in a first direction on the host
20 hair while allowing movement of the sleeve in a second opposing direction of the host hair.

 Preferably, the first direction is that which would allow the sleeve to be slid off the free end of the hair, and the opposing second direction would be in a direction toward the scalp from which the hair is growing. This allows the sleeve to be easily moved downward towards the scalp to adjust its position on the host hair as
25 needed, such as in response to growing of the host hair out of the scalp.

 Referring next to Figure 10, shown therein is a system 110 to increase the density of an existing set of hair including a shaft of hair 114 to which a sleeve 112 is attached by a clamp 116. The clamp is secured around the sleeve 112 with a clamp mechanism 118. It is to be understood that the clamp 116 is one form of an attachment
30 system for affixing the sleeve 112 to the host hair 114. In this aspect of the present disclosure, the clamp 116 is a band of high-strength elastic material, such as polyether ether ketone (one example of many plastics which would work) or other similar material that has a substantially cylindrical shape and is sized to fit over the exterior of the sleeve 112 and bear against the outer surface thereof. It is to be understood the
35 sleeve 112 can be configured as described above with respect to Figures 8 and 9 or with respect to Figures 1-7 described earlier.

Figure 11 shows the clamp 116 in enlarged detail to have the free ends 120, 122 separated from one another. The first free end 120 has a first hook member 124 extending at an acute angle inward and away from the free end 120. Similarly, the other mating free end 122 has a second hook member 126 that extends at an acute angle
5 from the second end 122 and away from an exterior surface 128 of the clamp 116. Thus, the first hook member 124 extends away from the interior surface 130 of the clamp 116 while the second hook member 126 extends away from the exterior surface 128 of the clamp 116. Each hook member may have a length in the range of 0.01 millimeter to 0.55 millimeter. The acute angle for each hook member 124, 126 is
10 preferably no greater than 45 degrees, and in one aspect of the present disclosure, is in the range of 10 degrees to 35 degrees. Ideally, the length of each hook member 124, 126 is as small as possible to minimize the amount of surface area that could be visible or contacted by a brush or comb.

In use, the clamp 116 has the first and second ends 120, 122 squeezed
15 together until the first hook member 124 slides up and beyond the second hook member 126 to snap in place between the second hook member 126 and the exterior 128 of the clamp 116. Pressure is then released on the clamp 116 to allow the first hook member 124 to seat in the space between the second hook member 126 and the exterior 128 of the clamp 116.

20 The clamp 116 can have a dimension that is substantially the same as the exterior dimension of the sleeve body 82 in terms of its length, or it can be shorter in length. The clamp mechanism 118 is dimensioned so as to force the clamp 116 to squeeze the sleeve 112 tightly around the shaft of the host hair 114. The compressibility of the sleeve will urge the clamp mechanism 118 to stay in engagement
25 and prevent release of the sleeve 112 from the host hair 114.

Figure 12 illustrates an alternative system 140 formed in accordance with the present disclosure in which a sleeve 142 is affixed to a host hair 144 by means of a clamp mechanism 146. In this design, the clamping mechanism 146 is integrally formed with the sleeve 142. More particularly, using the embodiment shown in Figure
30 11, the first end 120 of the clamp mechanism 146 is adhered or mounted to the exterior surface 148 of the sleeve with the first hook member 124 extending towards the sleeve 142. The second end 122 is likewise integrally formed with or attached to the sleeve 142 and has the second hook member 126 extending away from the sleeve 142 at an acute angle as described above with respect to Figure 11. When the sleeve 142 is
35 squeezed, such as with a pair of pliers, the first hook member 124 will engage the second hook member 126 in a manner as described above with respect to Figure 11.

The foregoing means for attachment systems for affixing the various configured sleeves to the host hair adopt a mechanical approach. An alternative approach would be to use only adhesive. This could be something as simple as the well-known SUPER GLUE product readily commercially available that would be applied to the interior surface of the sleeve or adjacent the first and second sidewalls of the slit of the sleeve. In addition, it can be applied to the sidewalls themselves, either exclusively or in combination with application to the interior surface of the sleeve. Alternatively or in combination therewith, a UV-activated adhesive can be applied. This allows the adhesive to be added well in advance of the attachment of the sleeve to the host hair. Once the sleeve is in the desired location and position on the host hair, the adhesive is activated by the activation of UV light. An example of a UV activated adhesive suitable for the present system would be the Loctite 4310, which when exposed to UV light cures within 2-5 seconds. Preferably a very thin coating of this adhesive is applied, which facilitates a quicker cure rate.

To adjust the sleeve, the UV light is used to heat the adhesive, thus loosening the attachment to the hair and allowing the sleeve to be slid on the hair towards the scalp. The serrations or cuts 98 prevent or resist sliding of the sleeve in an opposite direction away from the scalp.

As an example of a method of applying the sleeve to the host hair, the adhesive is applied shortly before the sleeve is installed. A trough to hold the adhesive and a pair of pliers are used in which an assistant to the installer dips the sidewalls of the sleeve, which is held by pliers, into the solution such that only the sidewalls of the sleeve receive the adhesive. This ensures that the installer always has a sleeve waiting and ready for him or her with adhesive fresh and wet on the sidewalls of the slit of the sleeve. The installer then captures the host hair, such as with their fingers, and combs the remaining hair away to the side. The pliers hold the sleeve with the slit facing outward from the pliers and the slit open so as to move the sleeve on to the hair from the side of the hair. After the sleeve is positioned around the hair at the desired distance from the scalp, the pliers are used to clamp the sleeve around the host hair. The UV light is then directed on the sleeve and the adhesive, which cures in 2-3 seconds. The installer is then free to move to the next host hair.

In accordance with one aspect of the present disclosure, the UV light is mounted directly on the pliers such that it is ready to shine at the appropriate location when needed. A trigger-style switch is included on the pliers to activate and deactivate the light. The sleeve is squeezed or "squished" onto its location and will grip the host

hair with sufficient force that it becomes very difficult to remove or slide off the host hair.

In addition to the foregoing gripping power, the cuts 98 previously described provide additional holding power. This holding power can be adjusted by the force applied when squishing the sleeve sidewalls together with the pliers.

Figures 13-17 illustrate one preferred process for making a sleeve populated with hair (each hair inside the sleeve wall). The first step shown in Figure 13 is to provide a sheet of thermoplastic material 150 dimensioned as described above. An opening 152 extends completely through the sheet of thermoplastic material 150 with a diameter of 0.04 mm. This diameter represents the smallest diameter found for a human hair.

The next step is to populate the sheet of thermoplastic with human (or synthetic) hair. To do this, a hair 154 is attached to the thermoplastic sleeve 150 by using a needle 156 having a diameter much larger than the diameter of the hair 154 as shown in Figure 14. The needle can have a diameter as large as 0.2 mm, and at the end of the needle a "pocket" or cavity 158 has been formed. The hair 154 seats down in the pocket 158 of the needle 156 and is also glued into the pocket 158 with an adhesive or glue. This prevents the hair 154 from being pulled away from the needle 156 as it passes through the sheet of thermoplastic material 150. Pushing the needle 156 through the sleeve 150 as shown in Figure 15 is not boring through the sleeve 150 but instead pushing the thermoplastic material aside. This ensures that the hair 154, which now has been pulled all the way through the material 150, will be held tightly by the thermoplastic material 150. This is in addition to the silane coating on the hair 154.

Once several hairs 154 have been threaded through and attached to the sheet of thermoplastic material 150, preferably in close proximity to what will be the center longitudinal bore of the eventual sleeve, a cylindrical micro tube 160 is placed over and engulfs all of the hair 154 as shown in Figure 16. It comes down over the thermoplastic sheet 150 and bores a hole with a diameter of 0.5 mm through the sheet 150 to create a sleeve having a cylindrical shape. If the sheet 150 is very thin, it is possible for the sleeve to have a ring configuration, although this is not preferred.

The cylindrical tube 160 with the hairs 154 embedded around the center hole 152 are then placed into a trough for the purpose of splaying the tube down to the center hole. As shown in Figure 17, a cutting tool 164 forms the longitudinal slit through the tube 160 and the cylindrical sheet 150 until it reaches the longitudinal opening 152. Once the slit is formed, the cylindrical clamp or the clamp members are attached to the exterior of the newly formed sleeve as previously described.

Figure 18 depicts a preferred method for attaching a thermoplastic sleeve 170 to a host hair 172. First, the host hair 172 is isolated by combing and then holding with one's fingers a single hair 172. A pair of pliers 174 are attached to the sleeve via the clamp members 176, 178 that in turn are attached to the sleeve 170 (as previously
5 described). The pliers 174 are constructed so that the jaws 180, 182 hold the slit 183 in the sleeve 170 open sufficiently to slide the sleeve over the host hair 172. The pliers 174 with the sleeve 170 held in the jaws 180, 182 approaches the host hair 172 from the side of the host hair 172 and very close to the scalp. The user moves the sleeve 170 with external clamp members 180, 182 over to capture the host hair 172 (much like a
10 hand gripping a pole). The pliers 174 are squeezed shut, thus locking the clamp members 180, 182 onto themselves as described above.

The distance of separation of one clamp member 180 from the other clamp member 182 is such that once the host hair 172 is captured and the pliers 174 lock the clamp members 180, 182 together, there will be an amount of gripping power
15 assured. The thicker the sleeve, the tighter the squeeze, the greater the gripping power.

Figure 19 represents a sleeve 184 with a large diameter that would allow hair to be embedded in to the wall 186 of the sleeve 184 at an angle. Even at one millimeter in diameter these sleeves are difficult to detect, especially when installed in the middle of the scalp near where the host hair meets the scalp and saturated with a
20 substantial number of hairs. The advantage to this "fat" sleeve is that the hair can be installed at angles to the surface, fewer installations are required, and the installations can be spaced further apart. Although Figure 19 shows the hairs curved, they could be embedded with the needle at angles but still form straight lines.

Figure 20 illustrates an example of a sleeve 188 that may be placed near
25 the hairline, preferably near where the hair meets the forehead. This is an ultra-thin sleeve 188 that is difficult to detect. Both the larger sleeve 184 and ultra-thin sleeve 188 are slit along their lengths and have the clamps added to them to allow for the preferred method of installation. These sleeves are difficult to detect, more so because they are saturated with a substantial number of hairs. Also, the sleeve length itself may
30 be shortened to possibly as short as 1/16" to help hide the sleeve near the scalp.

Figure 21 illustrates an example belt 201 that may be placed around a sleeve, such that the belt secures the sleeve to a host hair and has the supplemental hairs attached to the belt rather than being embedded in or directly connected to the sleeve. The belt 201 includes a plurality of fibers 204, such as Kevlar® fibers, in a weave
35 pattern 220. The weave pattern 220 may be rectangular and have a top edge 210, a bottom edge 214, a left edge 216, and a right edge 212. The fibers 204 in the weave

pattern 220 include a first set of fibers 206 that traverse from the left edge 216 to the right edge 212 of the belt 201 (e.g., horizontal fibers) and a second set of fibers 208 that traverse from the top edge 210 to the bottom edge 214 of the belt 201 (e.g., vertical fibers).

5 A subset 222 of the second set of fibers 208 extends beyond the top edge 210 of weave pattern 220, such that each fiber in the subset 222 includes a protruding portion outside a perimeter of the weave pattern 220. The subset 222 may include every other vertical fiber or every x number of vertical fibers so that the fibers in the subset 222 are evenly distributed from the left edge 216 to the right edge 212 of the
10 weave pattern 220. One or more supplemental hairs 224 are connected, such as by spot welds 226, to the protruding portion of each fiber in the subset of fibers 222.

In other implementations, the supplemental hairs may be connected to the weave pattern rather than to portions of fibers that protrude from the weave pattern, which is shown in Figure 22. Similar to the belt 201 shown in Figure 21, the belt 202 in
15 Figure 22 includes a plurality of fibers 227 in a weave pattern 228. The weave pattern 228 may be rectangular and have a top edge 229, a bottom edge 231, a left edge 232, and a right edge 230. The fibers 227 in the weave pattern 228 include a first set of fibers 233 that traverse from the left edge 232 to the right edge 230 of the belt 202 (e.g., horizontal fibers) and a second set of fibers 234 that traverse from the top edge 229 to
20 the bottom edge 231 of the belt (e.g., vertical fibers), similar to what is described above in conjunction with the weave pattern 220 of Figure 21.

Unlike the belt 201 in Figure 21 where vertical fibers in the weave pattern extend beyond the top edge 210 of the belt 201, one or more supplemental hairs 235 are connected directly to the outside face of the weave pattern 228. The
25 supplemental hairs 235 traverse from the bottom edge 231 (or a position within the weave pattern 228 between the bottom edge 231 and the top edge 229) of the weave pattern 228 and extend beyond the top edge 229 of the weave pattern 228. The supplemental hairs 235 are parallel to the vertical fibers 234 and may be connected to every other vertical fiber or every x number of vertical fibers in the weave pattern 228
30 so that the supplemental hairs 235 are evenly distributed from the left edge 232 to the right edge 230 of the weave pattern 228. The variable x can be any whole number from 1 to 20. In other implementations, the supplemental hairs 235 are integrated within the weave pattern 228 such the supplemental hairs 235 along with the vertical fibers 234 are evenly distributed from the left edge 232 to the right edge 230 of the weave pattern
35 228.

Figure 23 is a side view of a belt 203 having a tab-and-slit locking mechanism in accordance with the present disclosure. As described in more detail with respect to Figures 24A-24B, the belt 203 encases a sleeve, similar to the clamp 116 to close the sleeve around a host hair. The belt 203 includes a tab 238 at one end 247 (e.g., at the right edge of the weave pattern 236) and a slit 237 configured to accept and secure the tab 238 at the other end 248 (e.g., at the left edge of the weave pattern 236). Supplemental hairs can be connected to the weave pattern 236 in a variety of implementations as described above in conjunction with Figures 21 and 22.

Figures 24A-24B are cross-sectional views of a sleeve 240 and a belt 241 positioned around a host hair 246 in accordance with the present disclosure. The sleeve 240 is attached to a shaft of host hair 246 by the belt 241. The belt 241 may include a weave pattern and supplemental hairs 239 connected to the weave pattern in a manner similar to what is shown in Figures 21-22. In the implementation illustrated in Figure 24A, the supplemental hairs 239 are attached to the outside of the belt 241, such that the belt 241 is against the host hair 246. Exact positioning of the supplemental hairs 239, however, is not so limited. For example, in the implementation illustrated in Figure 24B, the supplemental hairs 239 are attached to the inside of the belt 241 and positioned between the belt 241 and the host hair 246. The belt 241 is secured around the sleeve 240 by a tab 242 and a slit 244 locking mechanism similar to what is shown in Figure 23. The belt 241 is sized to fit over the exterior of the sleeve 240 and bear against the outer surface thereof. It is to be understood the sleeve 240 can be configured as described above.

Figures 25-31 are various views of a plate with a v-groove for positioning a host hair in the sleeve in accordance with the present disclosure. Figure 25 is a perspective view of a plate 260 that provides a mechanism for an installer to added hair extensions to a customer's hair. The plate 260 includes a v-groove 256 for positioning a host hair 254 in a sleeve 252. The sleeve 252 is positioned in a cavity 262 below the v-groove 256. Briefly, the installer inserts the host hair 254 into the v-groove 256 and into the sleeve 252. The plate 260 includes clamping mechanisms that automatically clamp the sleeve 252 to the host hair 254 once the host hair 254 is properly positioned in the sleeve 252. Once clamped to the host hair 254, the host hair 254, the sleeve 252, and the supplemental hairs coupled to the sleeve 252 are slid through the cavity 262 in a longitudinal direction to the host hair 254.

Although Figure 25 illustrates only a single v-groove, other implementations may include a plurality of v-grooves. The plurality of v-grooves may be parallel or substantially parallel to one another. In this way, the installer can add

supplemental hairs to a plurality of different host hairs at one time. Once the plurality of host hairs are positioned into the plurality of v-grooves, the clamping mechanism clamps the corresponding sleeves to each host hair. In some implementations, the sleeve may be composed of a soft rubber that can deform around and attach to the host hair independent of a diameter of the host hair.

Turning now to Figures 26-31, shown therein is a plate 260 having a v-groove 256 for installing a sleeve 252 with one or more supplemental hairs 264 onto a host hair 254. The v-groove 256 extends from one edge of the plate 260 to the opposite edge of the plate 260. The sides of the v-groove 256 do not join at the apex, or bottom, of the v-groove 256. Rather the apex of the v-groove 256 opens into a cavity 262. The cavity 262 holds the sleeve 252 with the longitudinal slit in the body of the sleeve 252 positioned to accept the host hair 254 through the apex of the v-groove 256. The cavity 262 extends below the v-groove 256 from one edge of the plate 260 to the opposite edge of the plate to allow for the host hair 254, the sleeve 252, and the supplemental hairs 264 to be removed from the plate 260 after the sleeve 252 is clamped to the host hair 254.

The installer positions the host hair 254 into the v-groove 256 of the plate 260. Once the host hair 254 is positioned in the v-groove 256, the installer pushes down on the host hair 254 on both sides of the plate 260 (illustrated by the down arrows in Figures 26 and 27). This pressure forces the host hair 254 into the cavity 262 and into the sleeve 252, as shown in Figures 28 and 29. A sensor, or visual inspection by the installer, may be used to determine if the host hair 254 is properly positioned in the sleeve 252.

Once the host hair is positioned in the sleeve 252, the clamping mechanism 258 clamps the sleeve 252 to the host hair 254 (illustrated by the arrows in Figure 29). Once the sleeve 252 is secured to the host hair 254, the host hair 254 with the attached sleeve 252 and supplemental hairs 264 can be removed from the plate 260 by pulling the host hair 254 longitudinally through the cavity 262 (illustrated by the arrow in Figure 30).

It should be recognized that a belt, clamp, or other clamping member or mechanism, as described herein, can be used to secure the sleeve to the host hair. Other clamping mechanisms may include, but are not limited to, an adhesive strip. The adhesive strip can be wrapped around the sleeve to secure the sleeve to the host hair. The adhesive strip may be configured to wrap completely around the sleeve and attach to itself, which may include an adhesive on adhesive or other configuration. As the host hair grows, the sleeve can be pushed towards the scalp as described herein.

In some implementations, the adhesive strip may be permanent, and the sleeve may be removed by cutting the host hair below (or closer to the scalp) the sleeve, but the sleeve can move down the host hair as described herein. In other implementations, the adhesive strip may be removable so that the sleeve and
5 supplemental hairs can be removed from or repositioned on the host hair. Once the adhesive strip is removed from the sleeve, the opening of the sleeve expands allowing for the sleeve to be removed from the host hair.

Figures 32-36 illustrate various views of a sleeve with an install-ledge in accordance with the present disclosure. A sleeve 284 with supplemental hairs is
10 installed onto host hair 280. The supplemental hairs are not shown for ease of illustration, but can be attached to the sleeve in accordance with the present disclosure. The sleeve 284 can be installed onto and attached to the host hair 280 in a variety of different methods described herein. The sleeve 284 includes an upper portion 286 and a lower portion 288. The diameter of the lower portion 288 is greater than the diameter
15 of the upper portion 286 to create an install ledge 290. The install ledge 290 allows for a pair of tweezers 292 to push against the lower portion 288 while grasping the upper portion 286 when sliding the sleeve 284 longitudinally towards the scalp. In some implementations, a lubricant 282, such as vitamin E, may be applied to the host hair 280 between the sleeve 284 and the scalp to help reduce friction between the sleeve 284 and
20 the host hair 280.

In some implementations the sleeve may be made up of a soft thermoplastic material that is compressible around a host hair. The sleeve includes a longitudinal slit along the sleeve that accepts the host hair. The sleeve is then secured around the host hair using a number of different mechanisms described herein, which
25 compresses the sleeve against the host hair allowing the sleeve to grip the host hair. In at least one implementation, the slit may be similar to the slit 88 in the sleeve 80 in Figure 8, where the interior diameter of the sleeve may be less than the diameter of the host hair so that the sleeve compresses against the host hair when secured. In another implementation, the sleeve may not have an internal diameter, rather the sleeve has a
30 longitudinal wedge or “v-shape” groove that accepts the host hair. In the process of securing the sleeve to the host hair, the sleeve compresses and the wedge closes around the host hair.

The various embodiments described above can be combined to provide further embodiments. The various aspects of the present disclosure can be modified, if
35 necessary, to employ concepts of the various patents, applications and publications to provide yet further embodiments. For example, adhesive can be applied to the inside

diameter of the sleeve (near the middle of the sleeve) which stays at a high viscosity at temperatures up to 110 degrees F, but once heated (via the pliers which serve to adjust the location of the sleeve, when needed) to a temperature of 140 degrees F, the adhesive “melts” (lowers the viscosity) and allows the sleeve to be moved to its new location.

- 5 Once there, the pliers are released, the adhesive cools and “hardens” again, holding the sleeve firmly in place at its new location. This operating temperature of 140 degrees F is safe to work with under these conditions and will not burn the scalp because the heat is localized. An example of an adhesive that could be used to coat the inside diameter of the sleeve is 3M Scotch-Weld hot melt adhesive 3792 LM AE clear. This adhesive
- 10 has a “melting” point of 140 degrees F, *i.e.*, it turns from a high viscosity to a low viscosity and then back to a high viscosity when allowed to cool.

U.S. patent application Serial No. 14/257,786 filed April 21, 2014 is incorporated herein by reference, in its entirety.

- 15 These and other changes can be made to the embodiments in light of the above-detailed description. In general, in the following claims, the terms used should not be construed to limit the claims to the specific embodiments disclosed in the specification and the claims, but should be construed to include all possible embodiments along with the full scope of equivalents to which such claims are entitled. Accordingly, the claims are not limited by the disclosure.

CLAIMS

1. A system to increase an appearance of hair volume, the system comprising:
 - a sleeve configured to engage a host hair;
 - at least one supplemental hair extending from the sleeve; and
 - a clamp structured to secure the sleeve to the host hair while remaining on the sleeve and enabling the sleeve to slide in a first longitudinal direction on the host hair and resist sliding of the sleeve on the host hair in a second opposite longitudinal direction.
2. The system of claim 1 wherein the sleeve has a circumscribing sidewall formed of elastic, compliant material, the sleeve having an internal axial bore sized to have a diameter equal to or less than a diameter of the host hair to be received in the bore, the sleeve having an interior surface with at least one edge configured to engage the host hair and to prevent sliding of the sleeve in the second longitudinal direction on the host hair while permitting sliding of the sleeve on the host hair in the first longitudinal direction.
3. The system of claim 2, wherein the diameter of the internal axial bore of the sleeve is in a range of 1/4 the diameter of the host hair up to and including the diameter of the host hair.
4. The system of claim 2, wherein the sleeve is configured to be unaffected by UV and saltwater exposure.
5. The system of claim 2, wherein the at least one supplemental hair is embedded only in the circumscribing sidewall of the sleeve.
6. The system of claim 2, further comprising a hot melt adhesive applied to the interior surface of the sleeve that is structured to adhere the sleeve to the host hair when the adhesive is set and to allow the sleeve to move relative to the host hair when the adhesive is heated to a melting temperature of the adhesive.
7. The system of claim 1 wherein the sleeve has first and second ends and a longitudinal slit formed along an entire length of the sleeve from the first

end to the second end, the slit having a width defined by a distance between a first sidewall and a second sidewall of the sleeve.

8. The system of claim 7, wherein the clamp is configured to encircle the sleeve and squeeze the sleeve onto the host hair.

9. The system of claim 7, wherein the clamp comprises a first clamp member attached to the sleeve adjacent the first sidewall and a second clamp member attached to the sleeve adjacent the second sidewall, the first and second clamp members configured for making engagement to squeeze the sleeve onto the host hair.

10. The system of claim 7, further comprising an adhesive that attaches the sleeve to the host hair and is structured to temporarily lose adhesiveness to permit repositioning of the sleeve on the host hair.

11. The system of claim 10, wherein the adhesive comprises UV light activated adhesive.

12. The system of claim 1, wherein the at least one supplemental hair comprises a plurality of hair strands integrally embedded in a body of the sleeve.

13. A method of increasing hair density of existing hair, the method comprising:

attaching to the existing hair a sleeve having a plurality of hair strands;

and

securing the sleeve to the existing hair with a clamp to enable the sleeve to move in one direction on the existing hair and resist movement in an opposite direction on the existing hair.

14. The method of claim 13, further comprising repositioning the sleeve on the existing hair in response to growth of the existing hair.

15. The method of claim 13 wherein the attaching comprises using an adhesive that attaches the sleeve to the existing hair and is structured to temporarily lose adhesiveness to permit repositioning of the sleeve on the existing hair.

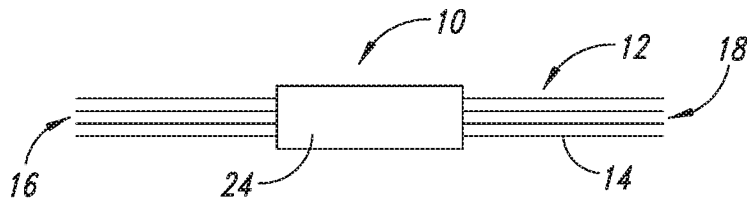

FIG. 1

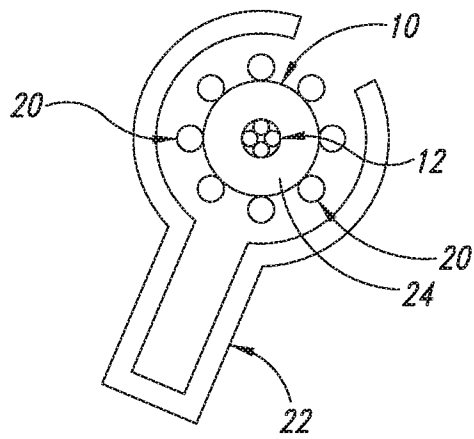

FIG. 2

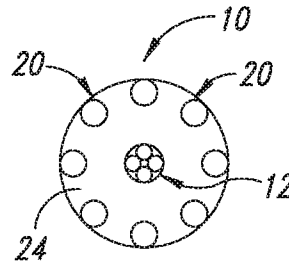

FIG. 3

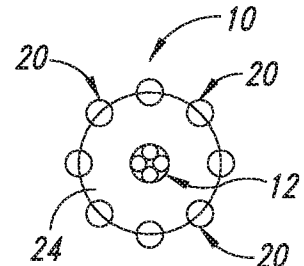

FIG. 4

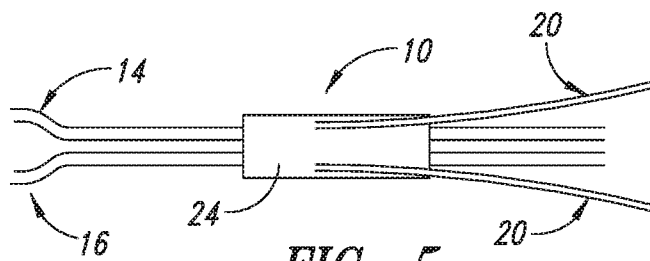

FIG. 5

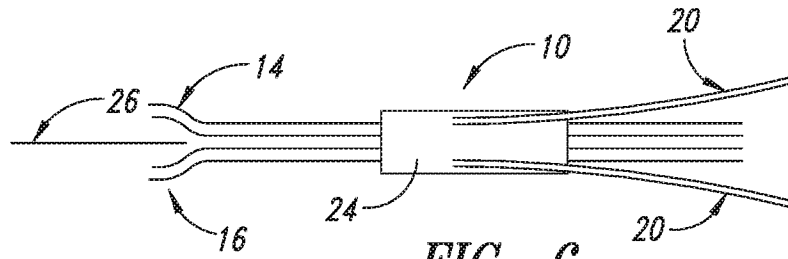

FIG. 6

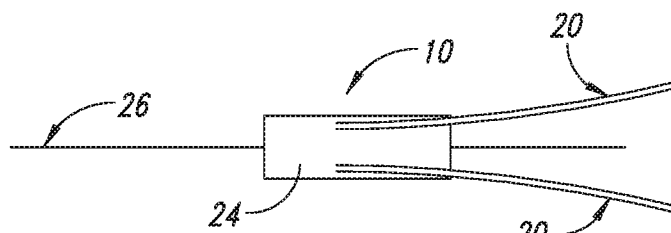

FIG. 7

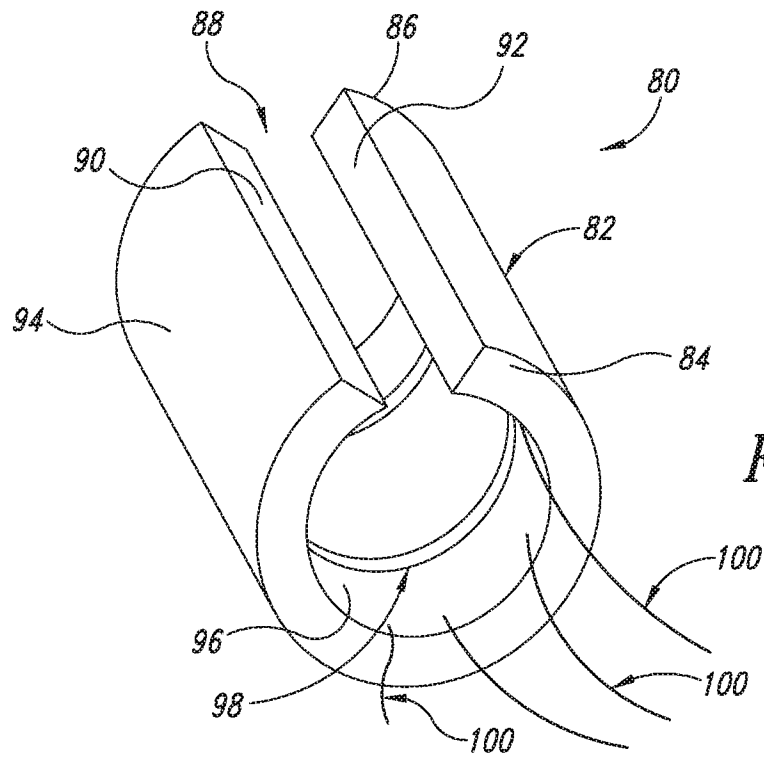

FIG. 8

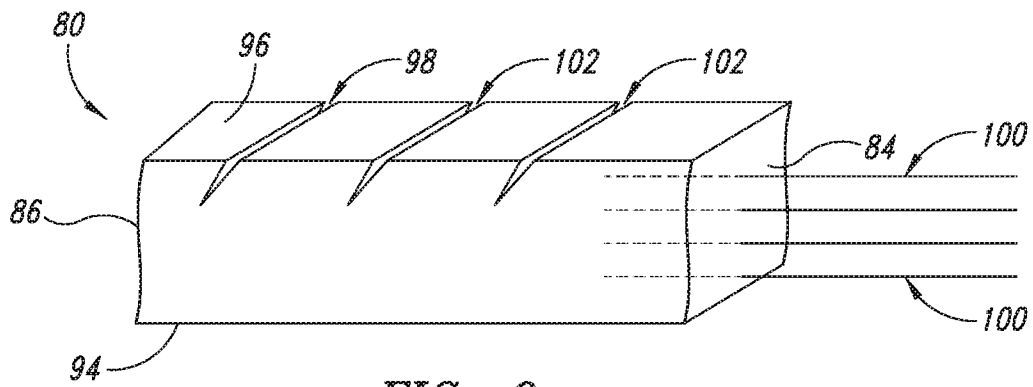

FIG. 9

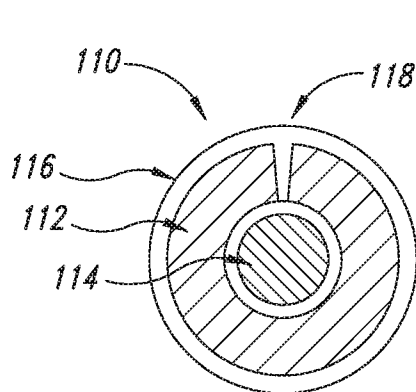

FIG. 10

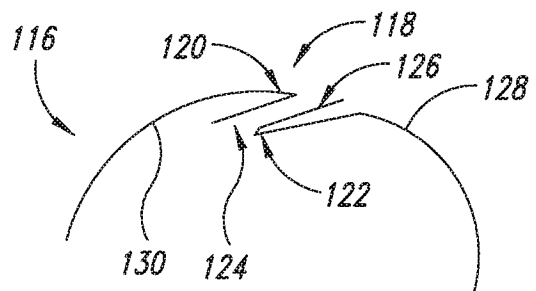

FIG. 11

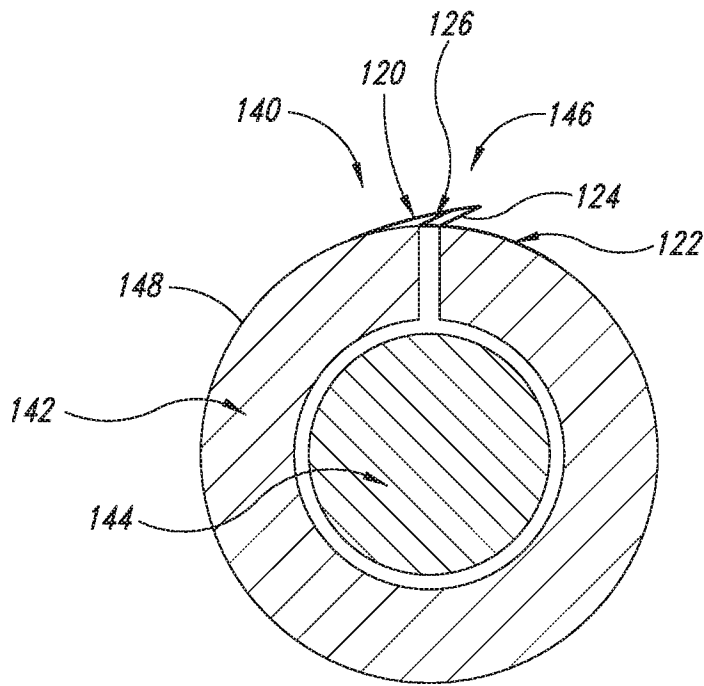

FIG. 12

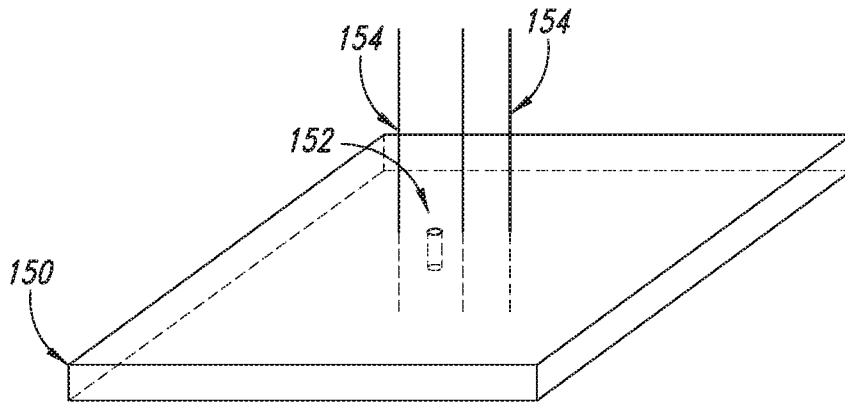

FIG. 13

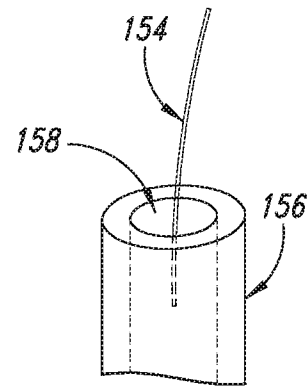

FIG. 14

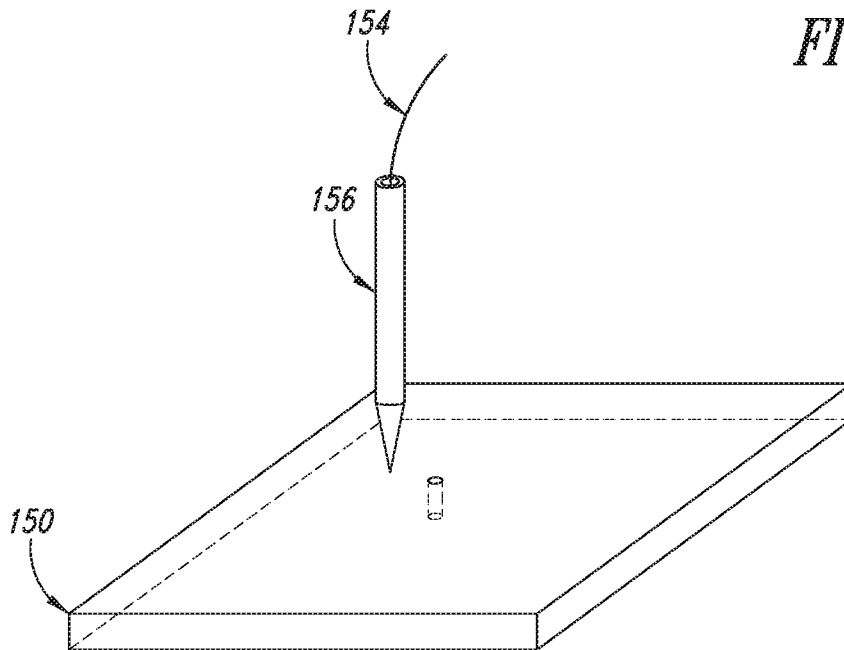

FIG. 15

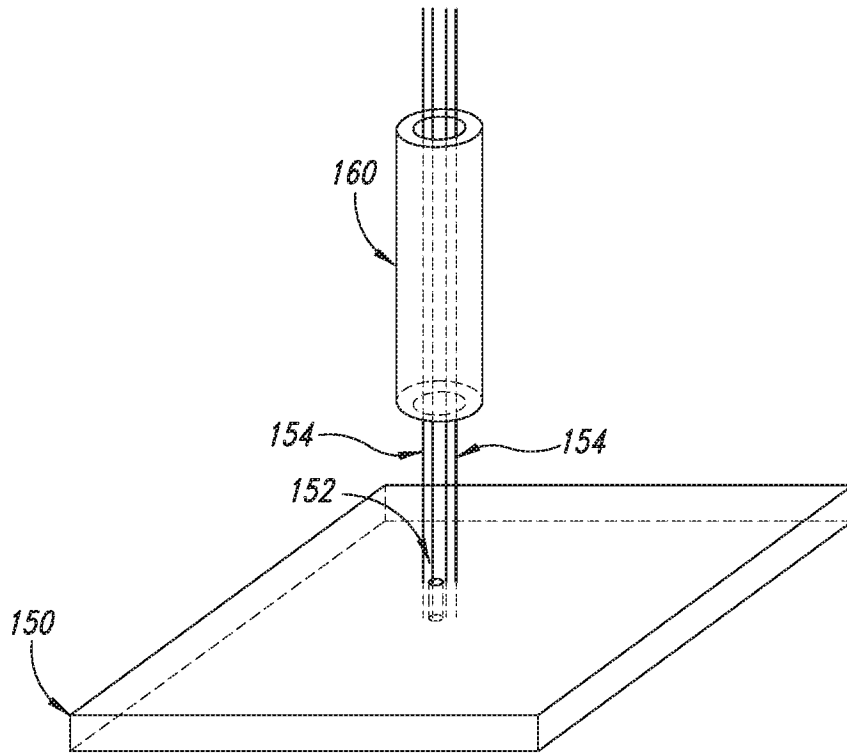

FIG. 16

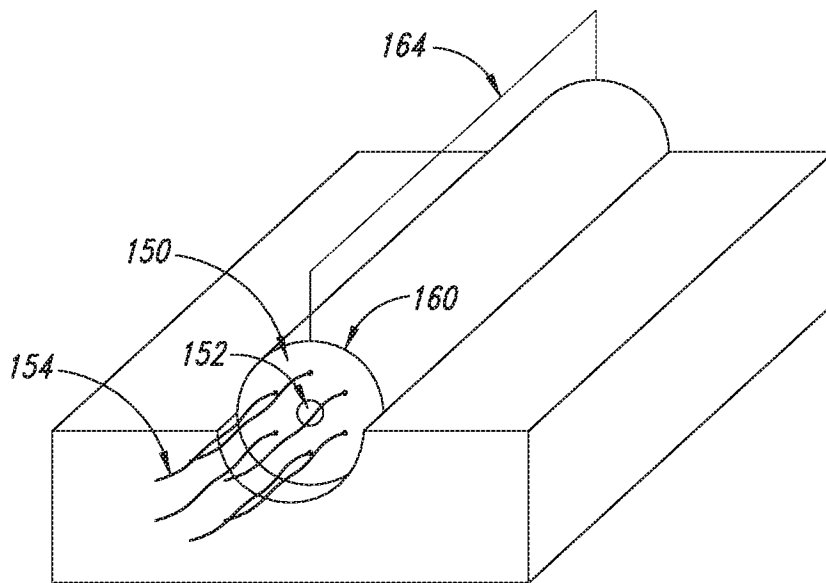

FIG. 17

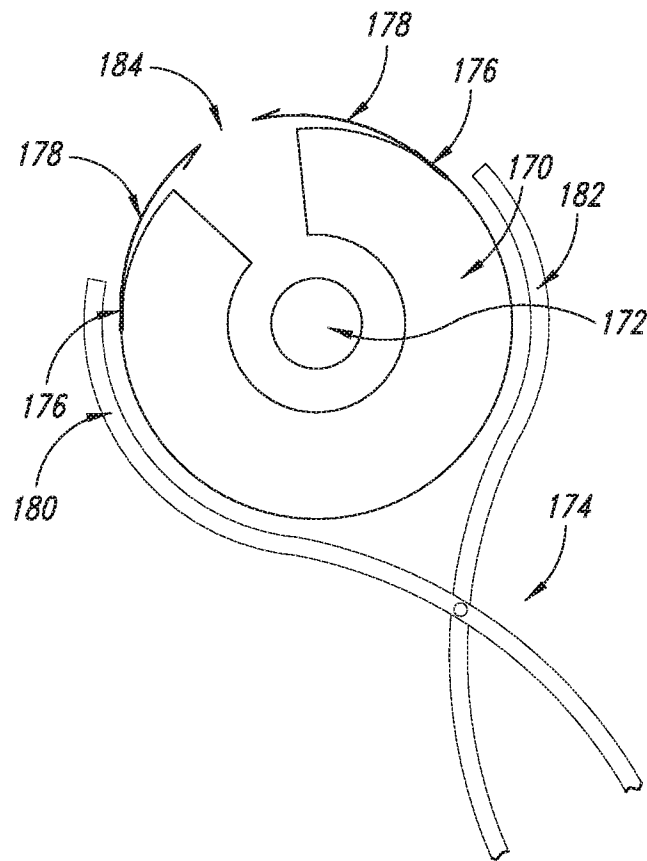

FIG. 18

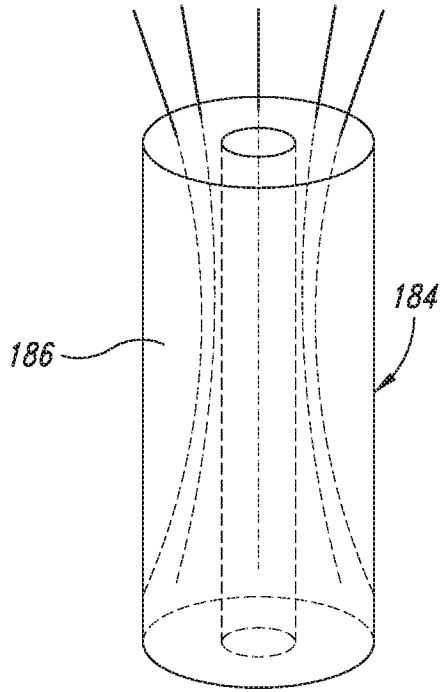

FIG. 19

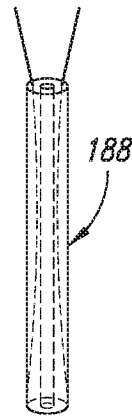

FIG. 20

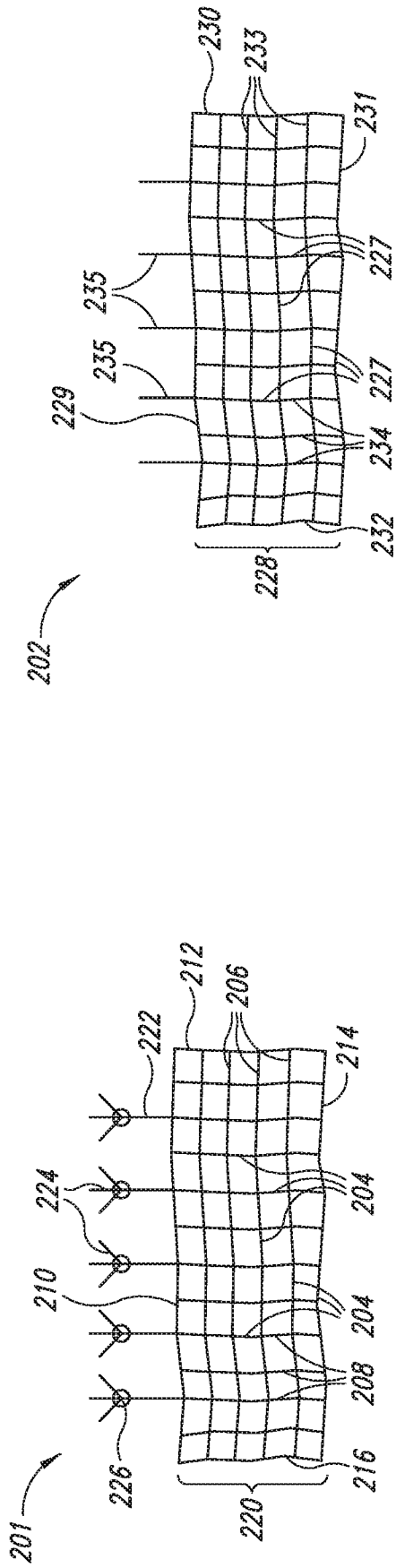

FIG. 22

FIG. 21

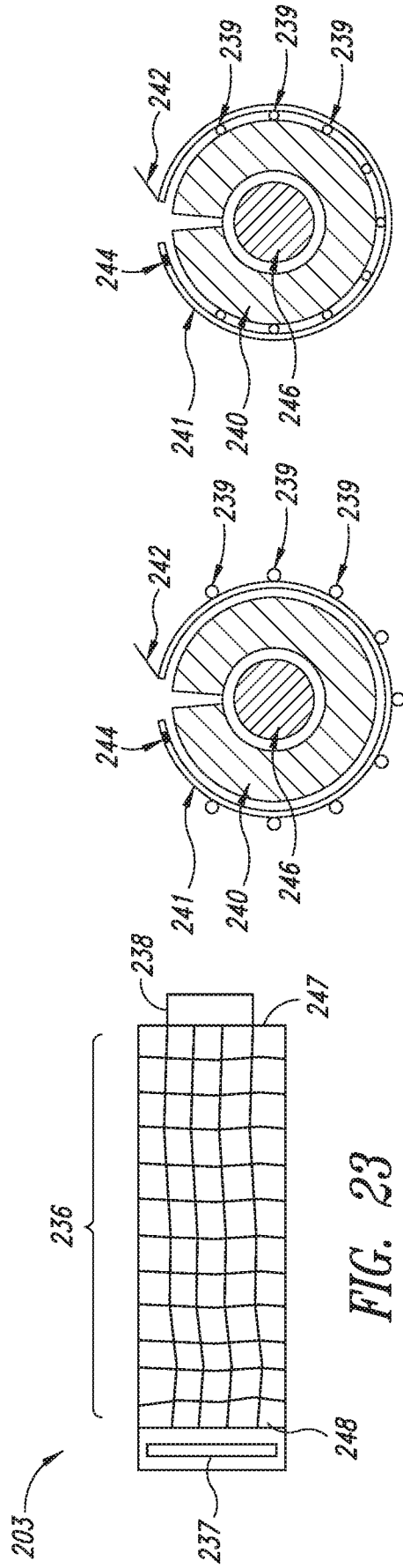

FIG. 23

FIG. 24A

FIG. 24B

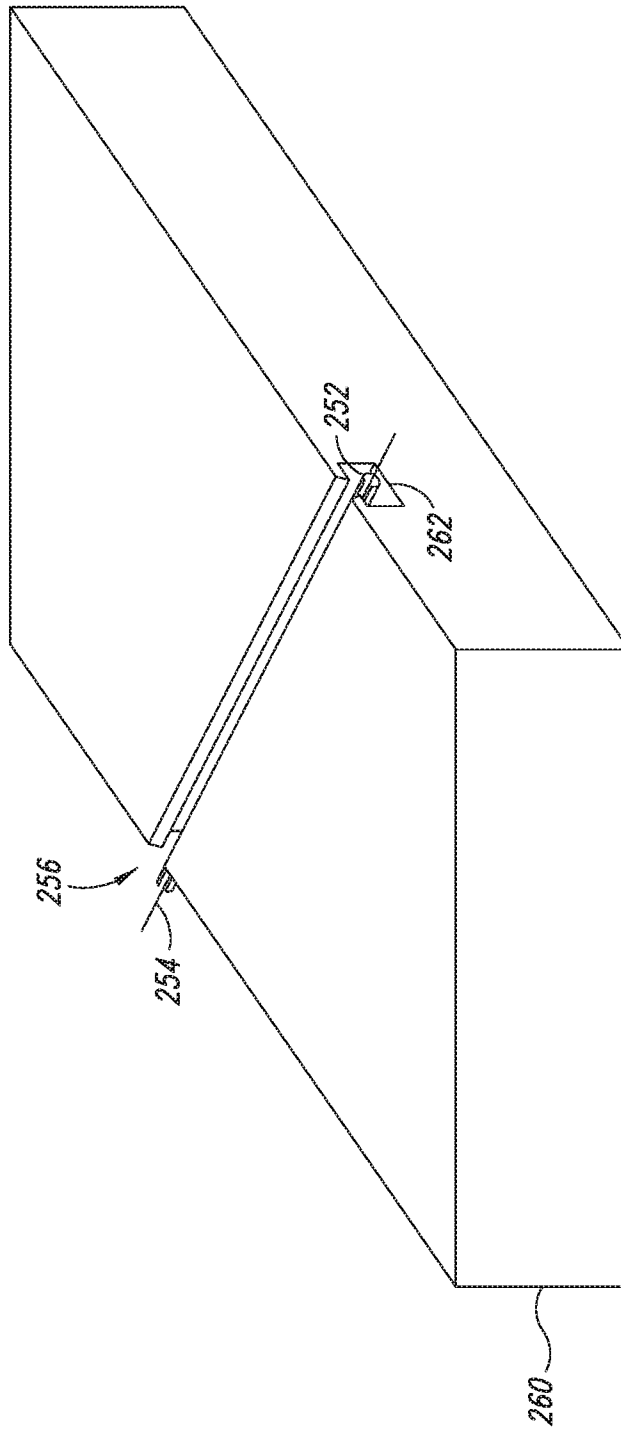

FIG. 25

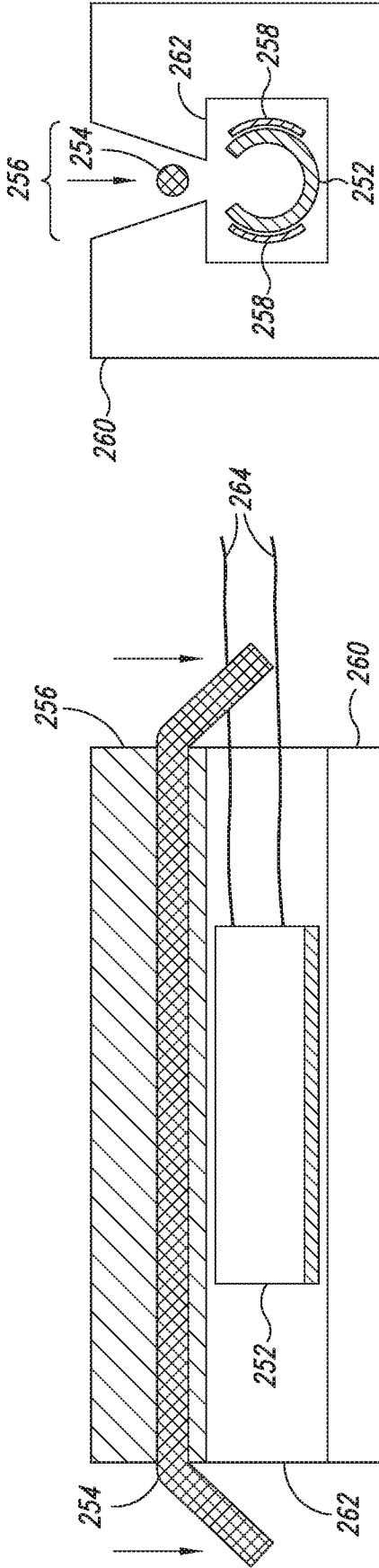

FIG. 26

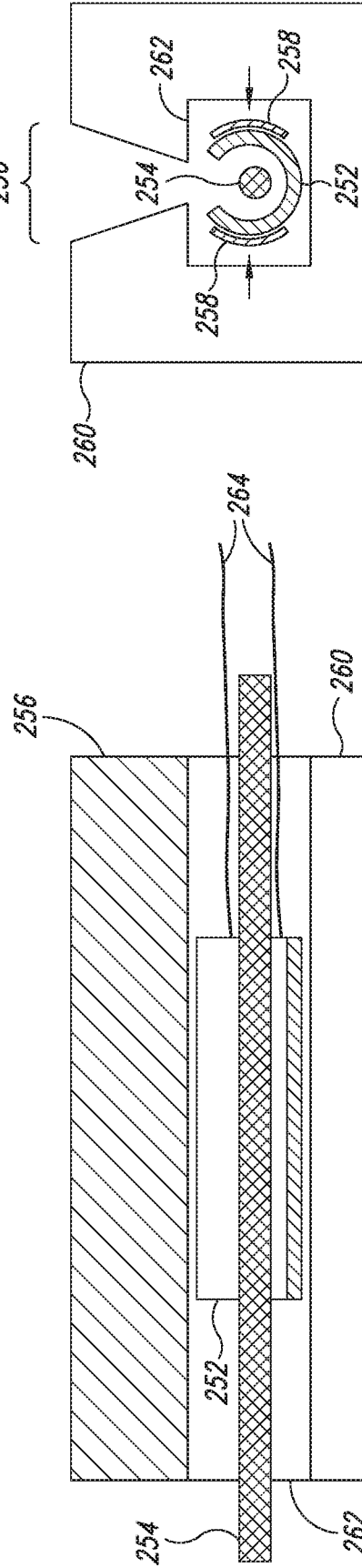

FIG. 28

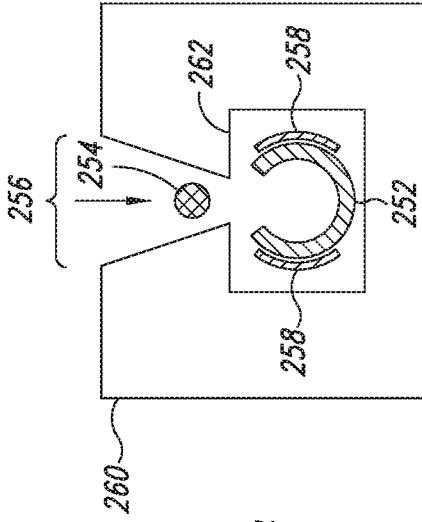

FIG. 27

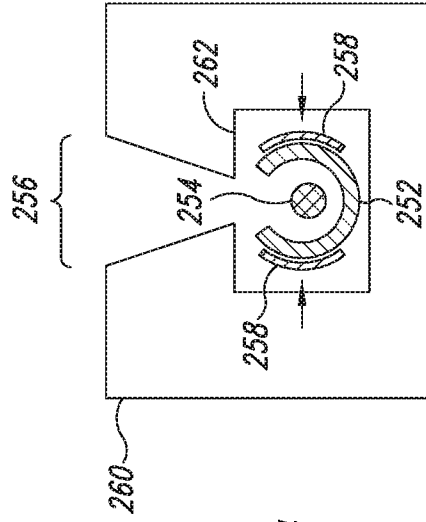

FIG. 29

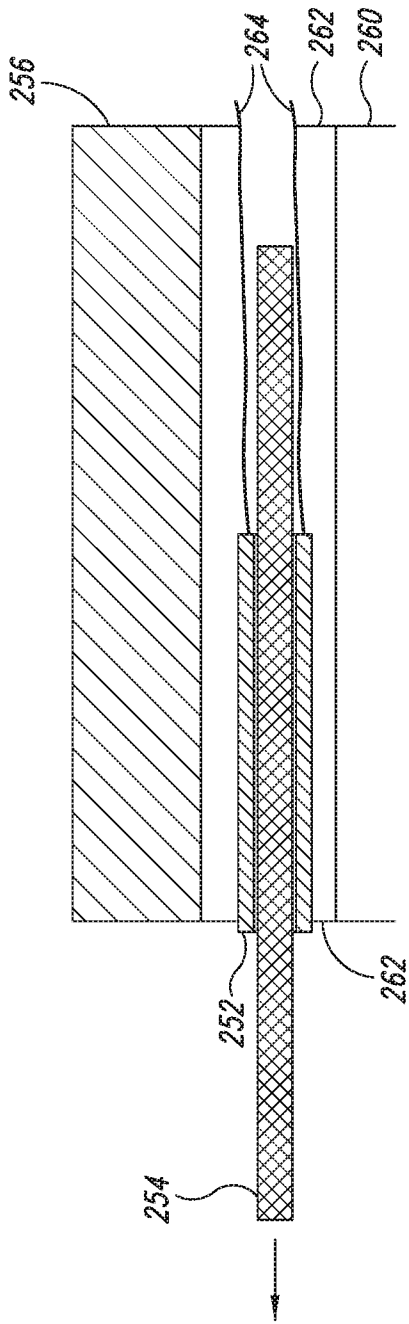

FIG. 30

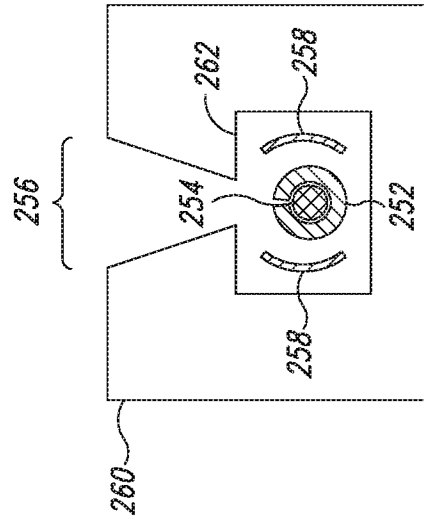

FIG. 31

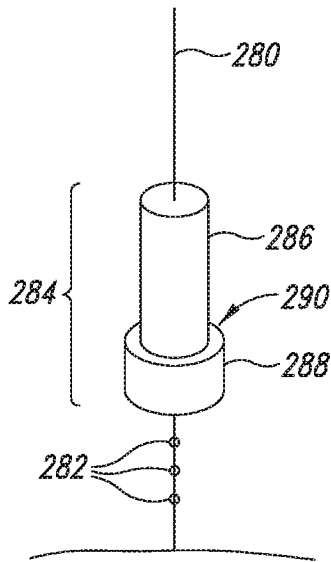

FIG. 32

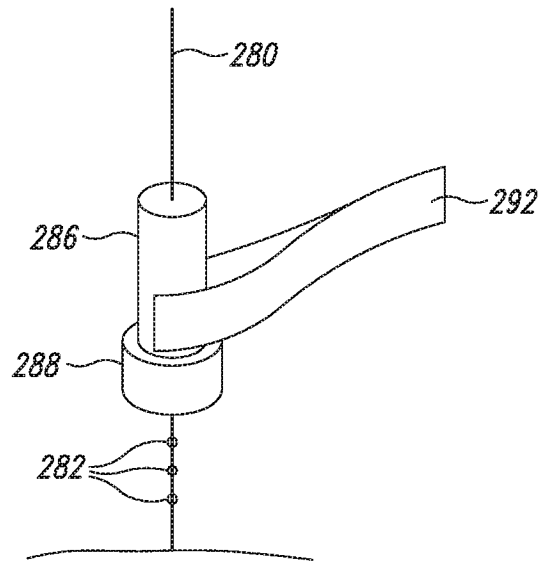

FIG. 33

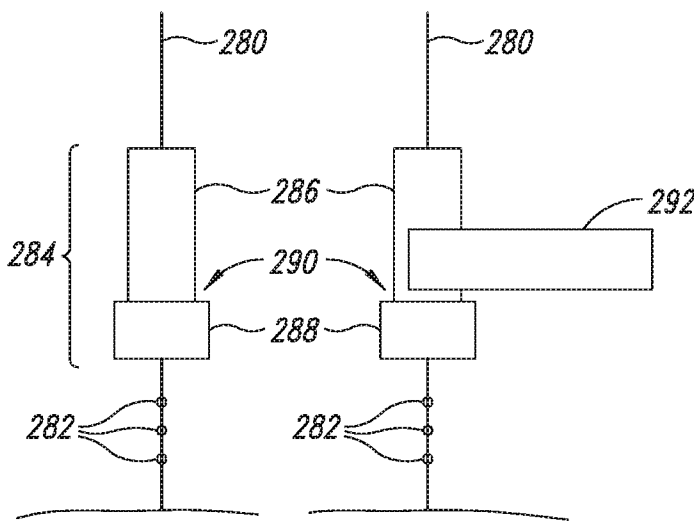

FIG. 34

FIG. 35

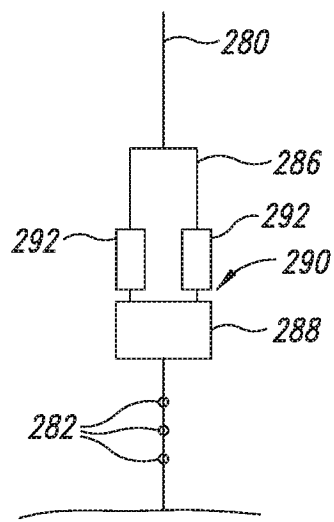

FIG. 36

INTERNATIONAL SEARCH REPORT

International application No.

PCT/US2016/052237

A. CLASSIFICATION OF SUBJECT MATTER IPC(8) - A41G 5/00; A41G 3/00 (2016.01) CPC - A41G 5/006; A41G 3/00; A41G 5/002; A41G 5/0026; A41G 5/004; A41G 5/0053 (2016.08) According to International Patent Classification (IPC) or to both national classification and IPC		
B. FIELDS SEARCHED Minimum documentation searched (classification system followed by classification symbols) IPC - A41G 3/00; A41G 5/00 CPC - A41G 3/00; A41G 5/002; A41G 5/0026; A41G 5/004; A41G 5/0053; A41G 5/006; A41G 5/0066; A41G 5/0073; A41G 5/008; A41G 5/0086; Y10T 24/398 Documentation searched other than minimum documentation to the extent that such documents are included in the fields searched USPC - 240/69AT; 24/115A; 24/714.8; 132/53; 132/54; 132/56; 132/201 (keyword delimited) Electronic data base consulted during the international search (name of data base and, where practicable, search terms used) Orbit, Google Patents, Google, Google Scholar Search terms used: hair, extension, tubular, sleeve, attachment, grow, adjustment, kit, clamp, wig, toupee.		
C. DOCUMENTS CONSIDERED TO BE RELEVANT		
Category*	Citation of document, with indication, where appropriate, of the relevant passages	Relevant to claim No.
X --- Y	US 2005/0268932 A1 (GOLD) 08 December 2005 (08.12.2005) entire document	1-6 --- 7-12
X	US 8,944,076 B1 (DOUBT) 03 February 2015 (03.02.2015) entire document	13-15
Y	US 2012/0124777 A1 (KELLER) 24 May 2012 (24.05.2012) entire document	7-12
A	US 2004/0149302 A1 (TODA) 05 August 2004 (05.08.2004) entire document	1-15
<input type="checkbox"/> Further documents are listed in the continuation of Box C. <input type="checkbox"/> See patent family annex.		
* Special categories of cited documents: "A" document defining the general state of the art which is not considered to be of particular relevance "E" earlier application or patent but published on or after the international filing date "L" document which may throw doubts on priority claim(s) or which is cited to establish the publication date of another citation or other special reason (as specified) "O" document referring to an oral disclosure, use, exhibition or other means "P" document published prior to the international filing date but later than the priority date claimed "T" later document published after the international filing date or priority date and not in conflict with the application but cited to understand the principle or theory underlying the invention "X" document of particular relevance; the claimed invention cannot be considered novel or cannot be considered to involve an inventive step when the document is taken alone "Y" document of particular relevance; the claimed invention cannot be considered to involve an inventive step when the document is combined with one or more other such documents, such combination being obvious to a person skilled in the art "&" document member of the same patent family		
Date of the actual completion of the international search 28 October 2016		Date of mailing of the international search report 17 NOV 2016
Name and mailing address of the ISA/US Mail Stop PCT, Attn: ISA/US, Commissioner for Patents P.O. Box 1450, Alexandria, VA 22313-1450 Facsimile No. 571-273-8300		Authorized officer Blaine R. Copenheaver PCT Helpdesk: 571-272-4300 PCT OSP: 571-272-7774