

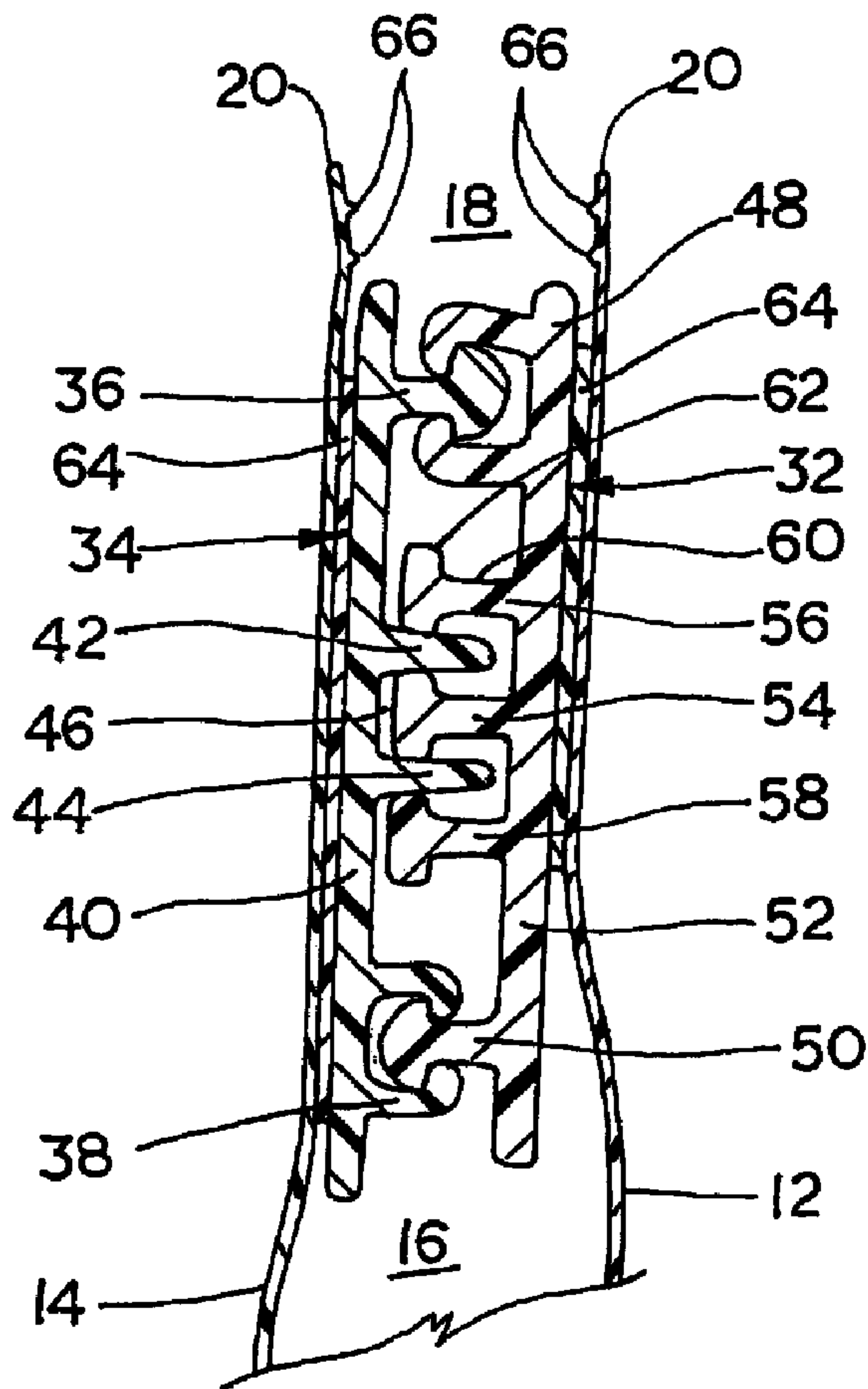

(22) Date de dépôt/Filing Date: 2008/03/12
 (41) Mise à la disp. pub./Open to Public Insp.: 2008/09/16
 (45) Date de délivrance/Issue Date: 2010/07/13
 (30) Priorité/Priority: 2007/03/16 (US11/725,120)

(51) Cl.Int./Int.Cl. *B65D 33/24* (2006.01)
 (72) Inventeurs/Inventors:
 DAIS, BRIAN C., US;
 ACKERMAN, BRYAN L., US;
 PAWLOSKI, JAMES C., US;
 TURVEY, ROBERT R., US;
 ZIMMERMAN, DANIEL P., US
 (73) Propriétaire/Owner:
 S. C. JOHNSON HOME STORAGE, INC., US
 (74) Agent: BERESKIN & PARR LLP/S.E.N.C.R.L.,S.R.L.

(54) Titre : SAC ET MECANISME DE FERMETURE ETANCHE A L'AIR REUTILISABLE CONNEXE
 (54) Title: POUCH AND AIRTIGHT RESEALABLE CLOSURE MECHANISM THEREFOR



(57) Abrégé/Abstract:

A pouch has an elongate closure mechanism adapted to provide vacuum retention within an interior of the pouch over an extended period of time when sealed. The closure mechanism includes a first pair of interlocking members that resealably mate together, a

(57) **Abrégé(suite)/Abstract(continued):**

second pair of interlocking members that resealably mate together, and a pair of sealing members that form an air tight seal separate from the interlocking members disposed between the first and second pairs of interlocking members. The closure members are connected with opposing panels of the pouch in a manner designed to provide differential opening and closing forces. The pouch may include a check valve and air evacuation channels to aid in evacuating air from the interior.

ABSTRACT OF THE DISCLOSURE

A pouch has an elongate closure mechanism adapted to provide vacuum retention within an interior of the pouch over an extended period of time when sealed. The closure mechanism includes a first pair of interlocking members that resealably mate together, a second pair of interlocking members that resealably mate together, and a pair of sealing members that form an air tight seal separate from the interlocking members disposed between the first and second pairs of interlocking members. The closure members are connected with opposing panels of the pouch in a manner designed to provide differential opening and closing forces. The pouch may include a check valve and air evacuation channels to aid in evacuating air from the interior.

-1-

TITLE

POUCH AND AIRTIGHT RESEALABLE CLOSURE MECHANISM THEREFOR

CROSS REFERENCE TO RELATED APPLICATIONS

[0001] Not applicable

REFERENCE REGARDING FEDERALLY SPONSORED RESEARCH OR
DEVELOPMENT

[0002] Not applicable

SEQUENTIAL LISTING

[0003] Not applicable

BACKGROUND OF THE INVENTION

1. Field of the Invention

[0004] The present invention relates generally to a resealable closure mechanism, such as may be used on a thermoplastic pouch.

2. Description of the Background of the Invention

[0005] Thermoplastic pouches having one or more resealable closure mechanisms extending along an opening into an interior thereof are often used to store perishable contents, such as food. In order to keep the food stored inside the pouch fresh for an extended period, users may press excess air out of the bag before completely sealing the closure mechanism. Other pouches have been developed that have a separate air evacuation route so that air may be removed from the pouch after the closure mechanism has already been sealed. Some such pouches allow a vacuum to be formed inside the pouch and then be sealed so as to vacuum pack the contents of the pouch.

-2-

[0006] Special resealable closure mechanisms have been used in an attempt to maintain the vacuum in the pouch over extended periods of time. Those closure mechanisms include two opposing closure elements that form an interlocking section and a sealing section in an attempt to form an airtight seal. For example, in some such closure mechanisms, one closure element includes a sealing member spaced between two in-turned hooks and the other closure element includes a channel defined by and between two out-turned hooks. The sealing member abuts against inside surfaces of the out-turned hooks to form a seal therewith.

[0007] In other such closure mechanisms, each closure element includes a sealing member disposed between two interlocking members. The sealing members press against each other when the interlocking members are appropriately interlocked to form the seal. In one closure mechanism, for example, one closure element includes two spaced out-turned male hooks that interlock with two complementary in-turned female hooks. A pressing rib spaced between the out-turned male hooks is wedged into a tapered channel defined by two tightening walls spaced between the in-turned female hooks. Each tightening wall also presses against an inner surface of the adjacent out-turned male hook.

[0008] In another closure mechanism, one closure element has two interlocking bulbous members spaced between two asymmetrical arrow-shaped members projecting from one base. The other closure element has three interlocking bulbous members spaced between two interlocking groove elements projecting from another base. The closure elements resealably mate with each asymmetrical arrow-shaped member interlocked with the opposing groove element and the two interlocking bulbous members on the one closure element engaged in a tight interfering fit between successive ones of the interlocking bulbous members on the other closure element sufficient to form a vacuum seal therebetween. One of the closure elements has a backing member that may be attached directly to a bag wall, and the other closure element has a backing member that is attached at only one end to another flange element that may be attached directly to a bag wall.

SUMMARY OF THE INVENTION

[0009] According to one aspect of the invention, an airtight resealable closure mechanism having an elongate profile extending between a first end and a second end includes a first closure element and a second closure element. The first closure element has a first interlocking member, a second interlocking member, and a first sealing member, each

protruding from a first base member. The first sealing member is disposed between the first and second interlocking members. The second closure element has a third interlocking member, a fourth interlocking member, and a second sealing member, each protruding from a second base member. The second sealing member forms a tapered channel and is disposed between the third and fourth interlocking members. The first and second interlocking members are resealably interlocked with the third and fourth interlocking members, respectively, and the first sealing member is wedged into the tapered channel of the second sealing member, wherein an airtight seal is formed. The first and second sealing members are spaced from each of the first, second, third, and fourth, interlocking members.

[0010] According to another aspect of the invention, a resealable airtight closure mechanism includes a first elongate profile resealably interlocked with a second elongate profile, wherein each elongate profile extends longitudinally between two ends. The first profile includes a first sealing wall spaced between an arrow-shaped first male interlocking member and a channel-shaped first female interlocking member, each projecting from one side of a first base member. The second profile includes a first sealing rib and a second sealing rib spaced between a channel-shaped second female interlocking member and an arrow-shaped second male interlocking member, each projecting from one side of a second base member. Each sealing rib includes a bulbous head spaced from the first base member. The first male interlocking member is interlocked with the second female interlocking member and the first female interlocking member is interlocked with the second male interlocking member. Also, the sealing wall is wedged between first sealing rib and the second sealing rib, whereby an airtight seal is formed between the sealing wall and each bulbous head.

[0011] According to yet another aspect of the present invention, a resealable pouch includes a front panel connected with a back panel along a peripheral edge to define a sealable interior space therebetween, and an opening is defined between the front and back panels along a top edge. A first elongate closure profile extends along the front panel proximate the opening, and a second elongate closure profile extends along the back panel proximate the opening. The first closure profile is releasably interlockable with the second closure profile to seal and unseal the opening. Further, the first closure profile includes a sealing member spaced between a first interlocking member and a second interlocking member, and the second closure profile comprises a second sealing spaced between a third

interlocking member and a fourth interlocking member. The first sealing member is sealingly engaged with the second sealing member, and the first and second interlocking members are interlocked with the third and fourth interlocking members, respectively. The first closure profile is continuously connected to the front panel between the first interlocking member and the second interlocking member, and the second closure profile is continuously connected to the back panel between the third interlocking member and the second sealing member. The second closure profile is not connected to the back panel proximate the fourth interlocking member.

[0012] Other aspects and advantages of the present invention will become apparent upon consideration of the following detailed description.

BRIEF DESCRIPTION OF THE DRAWINGS

[0013] FIG. 1 is an isometric view of a pouch and an airtight closure mechanism according to one aspect of the present invention; and

[0014] FIG 2 is a partial cross-sectional view along the line 2-2 of FIG. 1 with portions behind the plane of the cross-section omitted for clarity.

DETAILED DESCRIPTION

[0015] As seen in FIGS. 1 and 2, a resealable pouch 10 includes a front panel 12 and a back panel 14 that are connected, such as by folding, heat seal, and/or adhesive, along three peripheral edges to define a sealable interior space 16 therebetween, and an opening 18 is defined along a top edge 20 where the front and back panels are not connected so as to allow access to the interior space. A resealable elongate closure mechanism 22 extends along the front and back panels 12, 14 near the opening 18 between a left edge 24 and a right edge 26 of the pouch 10 to allow the opening to be repeatedly sealed and unsealed, thereby closing and opening, respectively, the opening. Preferably, the closure mechanism 22 provides an airtight seal such that a vacuum may be maintained in the interior space 16 for an extended period of time, such as days, months, or years, when the closure mechanism is sealed fully across the opening 18. In one embodiment, the pouch 10 may include a second opening through one of the panels 12, 14 covered by a vacuum check valve 28 to allow air to be

evacuated from the interior space 16 and maintain the vacuum when the closure mechanism 22 has been sealed. The pouch 10 may also include relief on or along an interior surface of one or both of the front and back panels 12, 14 to provide air flow channels 30 between the panels when a vacuum is being drawn through the check valve 28. In this manner, the pouch 10 provides a complete evacuable system within which food, for example, may be stored in a reusable vacuum pouch.

[0016] As best seen in FIG. 2, the closure mechanism 22 includes a closure element 32 that releasably interlocks and seals with an opposing closure element 34. Each closure element 32, 34 has a substantially constant elongate cross-sectional profile that extends longitudinally between the left edge 24 and right edge 26 of the pouch 10 to form a continuous seal therealong when fully interlocked with the opposing closure element. In one embodiment, closure element 32 is disposed along the front panel 12 and the closure element 34 is disposed along the back panel 14 opposite the first closure element so as to resealably interlock along an entire length thereof.

[0017] The closure element 34 has an elongate closure profile including a sealing section spaced between two interlocking members 36, 38, each projecting from a common side of a base member 40. In one embodiment, the interlocking member 36 has an arrow-shaped male interlocking profile, and the interlocking member 38 has a channel-shaped female interlocking profile. The arrow-shaped male interlocking profile 36 includes a shaft extending outwardly from the base member 40 and a symmetrical head with barbs extending from opposite sides of a distal end of the shaft spaced from the base member. The channel-shaped female interlocking profile 38 includes two spaced arms extending from the base member 40, each arm having an in-turned hook at a distal end thereof, to form a channel therebetween. The sealing section of the closure element 34 includes a sealing wall 42 and a sealing wall 44 spaced apart and projecting outwardly from the base member 40. The sealing walls 42, 44 in one embodiment are tapered, having a tip that is narrower than a base, thereby forming a tapered channel 46 therebetween. In one embodiment, the sealing walls 42, 44 and the male and female interlocking profiles 36, 38 are all approximately the same height from the base member 40.

[0018] The closure element 32 has an elongate second closure profile including a sealing section spaced between two interlocking members 48, 50, each projecting from a common side of a base member 52. In one embodiment, the interlocking member 48 has a channel-

shaped female interlocking profile, and the interlocking member 50 has an arrow-shaped male profile, complementary with the respective male and female interlocking profiles 36, 38, respectively, of the closure profile 34. The sealing section of the closure element 32 includes at least one sealing rib that wedges into the tapered channel 46 between the opposing sealing walls 42, 44. In one embodiment, the sealing section includes a first sealing rib 54 disposed between a second sealing rib 56 and a third sealing rib 58. Each sealing rib 54, 56, 58 has a bulbous head 60, such as a cross member, spaced from the base member 52 proximate a distal end of a wall 62, which projects from the base member 52. In one embodiment, each sealing rib 54, 56, 58 has a T-shaped cross-section. In other embodiments, the bulbous head 60 may have other shapes that project laterally from the wall 62, such as rounded, asymmetrical, slanted, or multiple projections, for example.

[0019] In a sealed state, the male interlocking profile 50 is interlocked with the female interlocking profile 38, and the female interlocking profile 48 is interlocked with the male interlocking profile 36. The bulbous head 60 of the sealing rib 54 is wedged tightly into the tapered channel 46 against the sealing walls 42, 44. The sealing wall 42 is wedged tightly between and against the bulbous heads 60 of the sealing rib 54 and the sealing rib 56, and the sealing wall 44 is wedged tightly between and against the bulbous heads 60 of the sealing rib 54 and the sealing rib 58. Preferably, the geometry of the sealing walls 42, 44 and the sealing ribs 54, 56, 58 is such that, when the interlocking profiles 36, 38, 48, 50 are occluded together in the sealed state, the distal ends of the sealing walls are spaced from the base member 52 and the bulbous heads 60 are spaced from the base member 40, thereby ensuring four air tight seals across the closure profiles 32, 34 between the interlocking profiles 36, 48 and 38, 50. Further, the sealing sections are spaced from each interlocking member 36, 38, 48, 50, which provides a sealing section that forms an air tight seal independently of the interlocking members. Of course, more or fewer sealing walls and sealing ribs may be used in other embodiments to form more or fewer air tight seals across the closure profiles.

[0020] In order to develop differential opening and closing forces, one of the closure elements may be secured continuously to the respective panel along the entire profile of the base member, and the other closure element may be secured partially to the respective panel along only a portion of the profile. For example, in one embodiment, the closure element 34 is connected with the back panel 14 continuously between the interlocking member 36 and the interlocking member 38. The closure element 32 is connected with the front panel 12

continuously between the interlocking member 48 and an interior side of the sealing rib 58, and an interior end of the closure element 32 is unconnected with the front panel 12 between the interior end of the base 52 and the interior side of the sealing rib 58. In this manner, differential opening and closing forces may be developed because the interior end and interlocking profile 50 of the base 52 of at least the closure element 32 is allowed to hinge away from the front panel 12, thereby minimizing an opening force caused by the contents pushing outwardly against the front and back panels 12, 14. In other embodiments, the interior end of either or both closure profiles 32, 34 may be unconnected with the respective panel 12 or 14, or the interior end of both closure profiles may be connected with the respective panel.

[0021] The closure elements 32, 34 may be connected with the respective front and back panels 12, 14 by many means, such as with adhesives or heat or ultrasonic welding. In one embodiment, the closure elements 32, 34 are connected with the respective panels 12, 14 using an intermediate layer 64 of connecting material, such as thermoplastic weld material, disposed between and connecting the base member 40, 52 of the closure element with the respective panel 14, 12. In this embodiment, a hot layer of thermoplastic weld material 64 applied between each closure element 32, 34 and the respective panel 12, 14 melts and attaches to both the panel and the base member, thereby forming a thermoplastic weld therebetween, which in some embodiments may provide a good continuous air tight seal between each panel and the respective closure member.

[0022] In one embodiment, the top edge 20 of one or both of the front and back panels 12, 14 extends upwardly beyond an exterior end of the respective closure profile 32, 34. One or more grip ridges 66 project from an interior side of one or both of the panels 12, 14 between the top edge 20 and the respective closure member 32, 34 to provide additional finger traction for opening the closure mechanism.

[0023] In a further embodiment, one or both of the closure elements 32, 34 may include one or more textured portions, such as a bump or crosswise groove in one or both of the interlocking members 36, 48, in order to provide a tactile sensation, such as a series of clicks, as a user draws the fingers along the closure mechanism to signify sealing of the closure elements across the opening. In another embodiment, all of the closure elements 36, 38, 48, 50 include textured portions along the length of the profile to provide tactile and/or audible sensations when closing the closure mechanism 22.

[0024] In one embodiment, the front and back panels 12, 14 and closure mechanism 22 are formed by known extrusion methods. For example, the panels 12, 14 may be extruded of thermoplastic material as a single continuous single- or multi-ply web, and the closure profiles 32, 34 may be extruded of the same or different thermoplastic material separately as continuous lengths or strands. The panels 12, 14 in one embodiment may be formed of multi-layer air impermeable film, such as an EVOH ply adhesively secured between polypropylene and low density polyethylene plies. One panel, such as the back panel 14, may be embossed or otherwise textured with a pattern, such as a diamond pattern, on both sides spaced between a bottom edge 68 and the closure mechanism 22 and may have a smooth area adjacent the bottom edge and top edge. The closure elements in one embodiment 32, 34 may be extruded primarily of molten polyethylene with various amounts of slip component, colorant, and tack additives in a separate process. The fully formed closure profiles 32, 34 may then be attached along opposite edges of one side of the web by placing or extruding a strip of molten thermoplastic weld material 64 onto the web along or adjacent to each edge of the web and immediately placing a closure member 32, 34 onto each strip of molten thermoplastic weld material. The thermoplastic weld material 64 may then be allowed to cool, the web folded together between the two edges to place the closure members 32, 34 in opposing resealable relation, and the web severed transverse to the web direction into discrete pouches, in a manner well known in the art, to form the pouch 10. According to another embodiment, the web, intermediate layer of connecting material 64, and the closure elements 32, 34 may be extruded together simultaneously, and subsequently cooled, folded, and cut. If used, the check valve 28 may be formed on and/or attached to the web prior to folding.

[0025] Of course, various details shown in FIGS. 1 and 2 may be modified within the spirit of the present invention. For example, the specific orientation of the closure profiles 32, 34 with respect to the interior 16 may be altered from the orientation shown in the drawings, such that, for example, the male interlocking profile 36 and the female interlocking profile 48 may be disposed on the interior side 16 of the sealing sections. In addition, the location and/or use of the check valve 28 and the air flow channels 30 may be modified as desired. Other methods and materials suitable for forming structures of the present invention may be also be used.

INDUSTRIAL APPLICABILITY

[0026] A pouch according to the present invention may be used to pack and store perishable items contained therein in an air-free or vacuum environment. According to one embodiment, the closure mechanism of the present invention can provide an air tight seal that is separate from the interlocking members so as to provide a more secure air tight seal. Clearly, many other and varied uses of the pouch and closure mechanism disclosed herein are also possible.

[0027] Numerous modifications to the present invention will be apparent to those skilled in the art in view of the foregoing description. Accordingly, this description is to be construed as illustrative only and is presented for the purpose of enabling those skilled in the art to make and use the invention and to teach the best mode of carrying out same. The exclusive rights to all modifications which come within the scope of the appended claims are reserved.

-10-

I/WE CLAIM:

1. An airtight resealable closure mechanism having an elongate profile extending between a first end and a second end, the profile comprising:

a first closure element having a first interlocking member, a second interlocking member, and a first sealing member, each protruding from a first base member, wherein the first sealing member is disposed between the first and second interlocking members; and

a second closure element having a third interlocking member, a fourth interlocking member, and a second sealing member, each protruding from a second base member, wherein the second sealing member forms a tapered channel and is disposed between the third and fourth interlocking members;

wherein the first and second interlocking members are resealably interlocked with the third and fourth interlocking members, respectively;

wherein the first sealing member is wedged into the tapered channel of the second sealing member, whereby an airtight seal is formed; and

wherein the first and second sealing members are spaced from each of the first, second, third, and fourth, interlocking members.

2. The resealable elongate closure mechanism of claim 1, wherein each of the first and fourth interlocking members comprises a pair of arms forming a channel-shaped female interlocking member, and wherein each of the second and third interlocking members comprises an arrow-shaped interlocking member.

3. The resealable elongate closure mechanism of claim 1, wherein the first sealing member comprises a first rib disposed between a second rib and a third rib, wherein the first rib includes a bulbous head, and wherein the bulbous head wedges within the tapered channel.

4. The resealable elongate closure mechanism of claim 3, wherein the second sealing member comprises a first wall spaced from a second wall to form the tapered channel therebetween, wherein the first wall is disposed between the first rib and the second rib, and the second wall is disposed between the first rib and the third rib.

-11-

5. The resealable elongate closure mechanism of claim 4, wherein each of the second rib and the third rib includes a bulbous head, wherein the first wall wedges between the bulbous heads of the first and second ribs and the second wall wedges between the bulbous heads of the first and third ribs.

6. The resealable elongate closure mechanism of claim 5, wherein each of the first, second, and third ribs is T-shaped.

7. The resealable elongate closure mechanism of claim 1, wherein the first and second closure elements comprise thermoplastic.

8. A resealable airtight closure mechanism comprising:

a first elongate profile resealably interlocked with a second elongate profile, wherein each elongate profile extends longitudinally between two ends;

the first profile comprising a first sealing wall spaced between an arrow-shaped first male interlocking member and a channel-shaped first female interlocking member, each projecting from one side of a first base member; and

the second profile comprising a first sealing rib and a second sealing rib spaced between a channel-shaped second female interlocking member and an arrow-shaped second male interlocking member, each projecting from one side of a second base member, wherein each sealing rib comprises a bulbous head spaced from the second base member;

wherein the first male interlocking member is interlocked with the second female interlocking member and the first female interlocking member is interlocked with the second male interlocking member, and

wherein the sealing wall is wedged between the first sealing rib and the second sealing rib, wherein an airtight seal is formed between the sealing wall and each bulbous head.

9. The resealable airtight closure mechanism of claim 8, wherein each bulbous head comprises a lateral member projecting outwardly from the sealing rib toward the sealing wall.

-12-

10. The resealable airtight closure mechanism of claim 8, wherein the sealing ribs are spaced between the first male interlocking member and the first female interlocking member.

11. The resealable airtight closure mechanism of claim 8, the first profile further comprising a second sealing wall extending from the side of the first base member between the first male interlocking member and the first female interlocking member, wherein the first and second sealing walls define a tapered channel therebetween, and wherein the bulbous head of the first sealing rib is wedged between the first and second sealing walls.

12. The resealable airtight closure mechanism of claim 11, the second profile further comprising a third sealing rib spaced between the second male interlocking profile and the second female interlocking profile, the third sealing rib comprising a bulbous head spaced from the second base member, wherein the first sealing wall is wedged between the first sealing rib and the second sealing rib, and the second sealing wall is wedged between the first sealing rib and the third sealing rib, whereby a first airtight seal is formed between the first sealing wall and the bulbous heads of the first and second sealing ribs and a second airtight seal is formed between the second sealing wall and the bulbous heads of the first and third sealing ribs.

13. The resealable airtight closure mechanism of claim 12, wherein the first sealing rib comprises a wall extending from the second base member and the bulbous head comprises a cross-beam disposed generally perpendicular to the wall proximate a distal end of the wall opposite the second base member.

14. The resealable airtight closure mechanism of claim 13, wherein each of the sealing ribs comprises a T-shaped member.

-13-

15. A resealable pouch comprising:

a front panel connected with a back panel along a peripheral edge to define a sealable interior space therebetween;

an opening defined between the front and back panels along a top edge;

a first elongate closure profile extending along the front panel proximate the opening, and a second elongate closure profile extending along the back panel proximate the opening, the first closure profile being releasably interlockable with the second closure profile to seal and unseal the opening, wherein the first closure profile comprises a sealing member spaced between a first interlocking member and a second interlocking member, and the second closure profile comprises a second sealing member spaced between a third interlocking member and a fourth interlocking member, wherein the first sealing member is sealingly engaged with the second sealing member, and the first and second interlocking members are interlocked with the third and fourth interlocking members, respectively;

wherein the first closure profile is continuously connected to the front panel between the first interlocking member and the second interlocking member; and

wherein the second closure profile is continuously connected to the back panel between the third interlocking member and the second sealing member and not connected to the back panel proximate the fourth interlocking member.

16. The resealable pouch of claim 15, wherein the fourth interlocking member is disposed on an interior side of the second sealing member.

17. The resealable pouch of claim 15, wherein the first closure profile is connected to the front panel by a substantially continuous first connecting layer disposed therebetween, and the second closure profile is connected to the back panel by a substantially continuous second connecting layer disposed therebetween.

18. The resealable pouch of claim 17, wherein at least one of the first and second connecting layers comprises a thermoplastic weld material.

-14-

19. The resealable pouch of claim 15 further comprising a grip ridge disposed on a portion of at least one of the front and back panels disposed on an exterior side of the closure profiles.

20. The resealable pouch of claim 15, wherein the first sealing member comprises a first sealing wall spaced from a second sealing wall and defining a tapered channel therebetween, wherein the second sealing member comprises a first sealing rib disposed between a second sealing rib and a third sealing rib, and wherein the first sealing rib is wedged between the first sealing wall and the second sealing wall within the channel, the first sealing wall is wedged between the first sealing rib and the second sealing rib, and the second sealing wall is wedged between the first sealing rib and the third sealing rib.

21. The resealable pouch of claim 20, wherein each of the first, second, and third sealing ribs has a bulbous head, and wherein each of the first and second sealing walls has tapered sides.

22. The resealable pouch of claim 20, wherein one of the first and second interlocking members is an elongate arrow-shaped interlocking profile and the other of the first and second interlocking members is an elongate channel-shaped interlocking profile, and wherein the third and fourth interlocking members are complementary respective elongate arrow-shaped male and elongate channel-shaped female interlocking profiles.

23. The resealable pouch of claim 15 further comprising a vacuum check valve disposed in at least one of the front and back panels through which air may be evacuated from the interior space.

24. The resealable pouch of claim 15 further comprising air flow channels defined along at least one of the front and back panels for allowing passage of air during evacuation of the pouch.

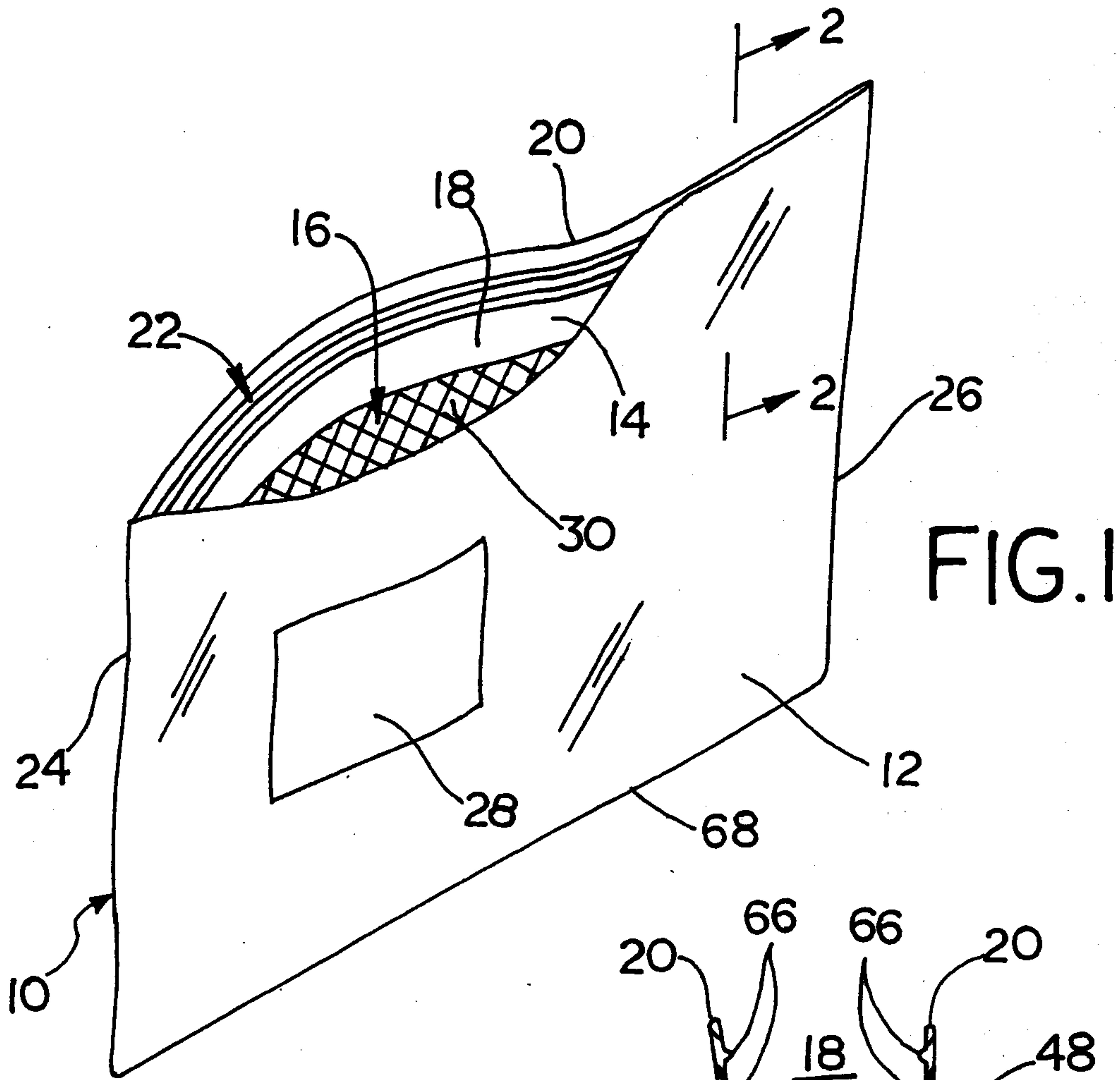

FIG. 1

FIG. 2

