



(51) International Patent Classification:

G01G 19/52 (2006.01) A63B 22/02 (2006.01)
G01G 19/44 (2006.01) G01G 7/00 (2006.01)

(21) International Application Number:

PCT/US2014/029401

(22) International Filing Date:

14 March 2014 (14.03.2014)

(25) Filing Language:

English

(26) Publication Language:

English

(30) Priority Data:

61/791,025 15 March 2013 (15.03.2013) US

(71) Applicant: **ICON HEALTH & FITNESS, INC.**
[US/US]; 1500 South 1000 West, Logan, UT 84321 (US).

(72) Inventors: **ASHBY, Darren**; 144 South State Street, Richmond, Utah 84333 (US). **LAW, Greg**; 931 East 80 North, Smithfield, Utah 84320 (US).

(74) Agent: **PRATT, Bryan G.**; Holland & Hart LLP, P.O. Box 11583, 222 S. Main Street, Suite 2200, Salt Lake City, Utah 84110 (US).

(81) Designated States (unless otherwise indicated, for every kind of national protection available): AE, AG, AL, AM, AO, AT, AU, AZ, BA, BB, BG, BH, BN, BR, BW, BY, BZ, CA, CH, CL, CN, CO, CR, CU, CZ, DE, DK, DM, DO, DZ, EC, EE, EG, ES, FI, GB, GD, GE, GH, GM, GT, HN, HR, HU, ID, IL, IN, IR, IS, JP, KE, KG, KN, KP, KR,

KZ, LA, LC, LK, LR, LS, LT, LU, LY, MA, MD, ME, MG, MK, MN, MW, MX, MY, MZ, NA, NG, NI, NO, NZ, OM, PA, PE, PG, PH, PL, PT, QA, RO, RS, RU, RW, SA, SC, SD, SE, SG, SK, SL, SM, ST, SV, SY, TH, TJ, TM, TN, TR, TT, TZ, UA, UG, US, UZ, VC, VN, ZA, ZM, ZW.

(84) Designated States (unless otherwise indicated, for every kind of regional protection available): ARIPO (BW, GH, GM, KE, LR, LS, MW, MZ, NA, RW, SD, SL, SZ, TZ, UG, ZM, ZW), Eurasian (AM, AZ, BY, KG, KZ, RU, TJ, TM), European (AL, AT, BE, BG, CH, CY, CZ, DE, DK, EE, ES, FI, FR, GB, GR, HR, HU, IE, IS, IT, LT, LU, LV, MC, MK, MT, NL, NO, PL, PT, RO, RS, SE, SI, SK, SM, TR), OAPI (BF, BJ, CF, CG, CI, CM, GA, GN, GQ, GW, KM, ML, MR, NE, SN, TD, TG).

Declarations under Rule 4.17:

- as to applicant's entitlement to apply for and be granted a patent (Rule 4.17(ii))
- as to the applicant's entitlement to claim the priority of the earlier application (Rule 4.17(iii))

Published:

- with international search report (Art. 21(3))
- before the expiration of the time limit for amending the claims and to be republished in the event of receipt of amendments (Rule 48.2(h))

(54) Title: DEVICES AND METHODS FOR DETERMINING THE WEIGHT OF A TREADMILL USER

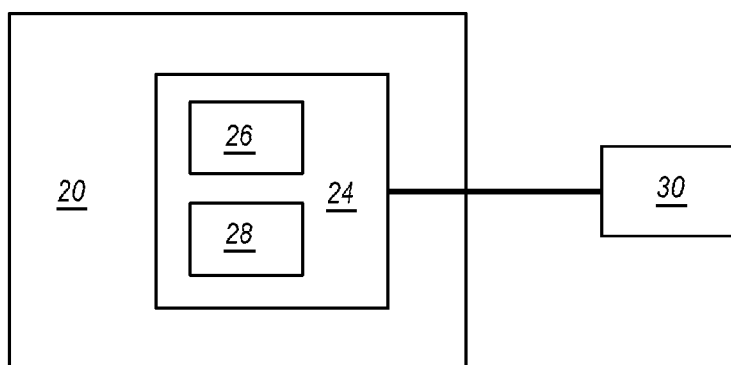

Fig. 2

(57) Abstract: A treadmill may comprise a drive motor positioned and configured to drive a treadbelt, and an electrical current sensor configured to measure the electrical current utilized by the drive motor. The treadmill may also include a computer programmed and configured to analyze the measured electrical current usage by the drive motor to determine the weight of a person positioned on the treadbelt. A person's weight may be determined by driving the treadbelt with the drive motor while a person is positioned on the treadbelt, measuring an electric current utilized by the drive motor, and analyzing the measured electric current to determine the weight of the person positioned on the treadbelt of the treadmill. Additionally, the measured weight may be utilized to calculate calorie expenditure.



Docket Number: 11-054.11.01PCT (59665.0503)

TITLE

Devices and Methods for Determining the Weight of a Treadmill User

CROSS-REFERENCE TO RELATED APPLICATIONS

[0001] This application claims priority to U.S. Provisional Patent application 61/791,025 filed on March 15, 2013.

TECHNICAL FIELD

[0002] The present disclosure relates to exercise equipment. More particularly, the present disclosure relates to treadmills and methods of determining the weight of a user on a treadmill.

BACKGROUND

[0003] The weight of a user may be required to utilize various features of a treadmill. For example, the calorie expenditure by a user while exercising on a treadmill may be more accurately estimated by utilizing the weight of the user. In view of this, prior to each use of a treadmill, a user may be required to input their current weight. This may be cumbersome and time consuming to the user, and requires that the user accurately know their current weight. Accordingly, a user may unintentionally input an inaccurate weight.

[0004] Also, it may be embarrassing to a user to enter their weight into a treadmill located in view of others, such as at a fitness club or gym, and disclose their current weight. Thus, the person may intentionally input an inaccurate weight to avoid disclosing their current weight to others. Accordingly, in addition to being a time consuming annoyance to users, requiring a user to enter their current weight via a treadmill console may result in inaccurate and unreliable results.

[0005] In view of the foregoing, it would be desirable to be able to acquire the weight of a treadmill user without requiring the user to input their weight manually into the treadmill. Additionally, it would be desirable to be able to calculate a reasonably accurate

Docket Number: 11-054.11.01PCT (59665.0503)

calorie expenditure by a user on a treadmill without first requesting that the user input their weight manually.

DISCLOSURE OF THE INVENTION

[0006] In one aspect of the disclosure, a method of determining a person's weight may comprise driving a treadbelt of a treadmill with a drive motor while a person is positioned on the treadbelt, measuring an electric current utilized by the drive motor, and analyzing the measured electric current to determine the weight of the person positioned on the treadbelt of the treadmill.

[0007] In one or more other aspects that may be combined with any of the aspects herein, may further include positioning the treadbelt to simulate a declining slope.

[0008] In one or more other aspects that may be combined with any of the aspects herein, may further include positioning the treadbelt to simulate an inclining slope.

[0009] In one or more other aspects that may be combined with any of the aspects herein, may further include analyzing the measured electric current to determine the weight of the person positioned on the treadbelt of the treadmill by comparing the measured electric current to a value on a lookup table.

[0010] In one or more other aspects that may be combined with any of the aspects herein, may further include analyzing the measured electric current to determine the weight of the person positioned on the treadbelt of the treadmill by inputting the measured electric current into a mathematical function.

[0011] In one or more other aspects that may be combined with any of the aspects herein, may further include driving the treadbelt of the treadmill with the drive motor while the person is positioned on the treadbelt by driving the treadbelt at a linear speed less than about 2.25 meters per second.

[0012] In one or more other aspects that may be combined with any of the aspects herein, may further include analyzing the measured electric current by analyzing an average measured electric current over a period of time.

[0013] In one or more other aspects that may be combined with any of the aspects herein, may further include determining a cadence of the person positioned on the treadbelt.

Docket Number: 11-054.11.01PCT (59665.0503)

[0014] In one or more other aspects that may be combined with any of the aspects herein, may further include analyzing an average measured electric current over a period of time by analyzing an average measured electric current over a period of time corresponding to the determined cadence.

[0015] In one or more other aspects that may be combined with any of the aspects herein, may further include changing the slope of the treadbelt while measuring the electric current utilized by the drive motor.

[0016] In one aspect of the present disclosure, a method of calculating calories expended while exercising on a treadmill may include measuring the weight of a person on a treadmill, and utilizing the determined weight to calculate calorie expenditure.

[0017] In one or more other aspects that may be combined with any of the aspects herein, may further include automatically determining the weight of the person on the treadmill by driving a treadbelt of the treadmill with a drive motor while the person is positioned on the treadbelt, measuring an electric current utilized by the drive motor, and analyzing the measured electric current to determine the weight of the person positioned on the treadbelt of the treadmill.

[0018] In one or more other aspects that may be combined with any of the aspects herein, may further include positioning the treadbelt to simulate a declining slope.

[0019] In one or more other aspects that may be combined with any of the aspects herein, may further include analyzing the measured electric current to determine the weight of the person positioned on the treadbelt of the treadmill by comparing the measured electric current to a value on a lookup table.

[0020] In one or more other aspects that may be combined with any of the aspects herein, may further include analyzing the measured electric current to determine the weight of the person positioned on the treadbelt of the treadmill by inputting the measured electric current into a mathematical function.

[0021] In one or more other aspects that may be combined with any of the aspects herein, may further include driving the treadbelt of the treadmill with the drive motor while the person is positioned on the treadbelt by driving the treadbelt at a linear speed less than about 2.25 meters per second.

Docket Number: 11-054.11.01PCT (59665.0503)

[0022] In one or more other aspects that may be combined with any of the aspects herein, may further include analyzing the measured electric current by analyzing an average measured electric current over a period of time.

[0023] In one or more other aspects that may be combined with any of the aspects herein, may further include determining a cadence of the person positioned on the treadmill.

[0024] In one aspect of the disclosure, a treadmill may comprise a platform, a treadmill extending over the platform, a drive motor positioned and configured to drive the treadmill, an electrical current sensor configured to measure the electrical current utilized by the drive motor, and a computer programmed and configured to analyze measured electrical current usage by the drive motor to determine the weight of a person positioned on the treadmill.

[0025] In one or more other aspects that may be combined with any of the aspects herein, may further include a rear deck height adjustment mechanism, and a front deck height adjustment mechanism.

BRIEF DESCRIPTION OF THE DRAWINGS

[0026] The accompanying drawings illustrate various embodiments of the present methods and systems and are a part of the specification. The illustrated embodiments are merely examples of the present systems and methods and do not limit the scope thereof.

[0027] FIG. 1 is a perspective view of a treadmill configured to automatically determine the weight of a user, according to an embodiment of the present disclosure.

[0028] FIG. 2 is a schematic view of a computer and sensor arrangement of the treadmill of FIG. 1.

[0029] FIG. 3 is a top view of a drive mechanism of the treadmill of FIG. 1.

[0030] FIG. 4 is a top view of deck height adjustment mechanisms of the treadmill of FIG. 1.

[0031] Throughout the drawings, identical reference numbers designate similar, but not necessarily identical, elements.

Docket Number: 11-054.11.01PCT (59665.0503)

BEST MODE(S) FOR CARRYING OUT THE INVENTION

[0032] In some embodiments, as shown in FIG. 1, a treadmill 10 may include a frame 12 and a deck 14 having a front end pivotally attached to the frame 12. The deck 14 may include a treadmill 16 that is exposed at an upper region of the deck and provides a movable, continuous running surface during operation of the treadmill 10. Additionally, the frame 12 may include one or more handrails 18 to provide support and balance to a user.

[0033] The treadmill 10 may additionally include a console 20. The console 20 may be mounted on the frame 12 of the treadmill 10 so that it may be readily accessible and viewable to a user positioned on the treadmill 10. The console 20 may include inputs and outputs to allow the user to communicate with the treadmill 10 via the console 20. The console 20 may include a visual display, such as a video screen 22 to provide visual communication to the user. The console 20 may also include an audio output, such as an audio jack for the connection of headphones and/or a speaker, to provide audio communication to the user. Input devices may facilitate the entry of data by a user, such as a desired operating speed for the treadmill 16, a desired incline, and information about the user. For example, the inputs of the console may include one or more of buttons, a touch screen, a microphone, and a camera for inputting information through the console 20.

[0034] The console 20 may include a computer 24 located therein, which may include a processor 26 and a memory 28, as illustrated in FIG. 2. In further embodiments, the computer 24 may not be located in the console 20, but may be in communication with the console 20. The computer 24 may be configured to receive data from the inputs of the console 20 and from sensors 30 of the treadmill 10.

[0035] As shown in FIG. 3, a drive motor 32 may be associated with the treadmill 16. The drive motor 32 may be positioned and configured to drive the treadmill 16. For example, the drive motor 32 may be connected to a roller 34 via a drive belt 36 and the treadmill 16 may be positioned over the roller 34.

[0036] The treadmill 10 may also include one or more sensors for collecting data while a user is running and/or walking on the treadmill 16. For example, a sensor 30 may be positioned and configured to sense the electrical current utilized by the drive motor 32. The computer 24 may be configured to receive data from the sensor 30 and to analyze the data with the processor 26.

Docket Number: 11-054.11.01PCT (59665.0503)

[0037] As shown in FIG. 4, the deck 14 may be supported by a deck frame 42, which may include a left side rail and a right side rail connected by laterally extending cross-members. A front roller may be rotatably coupled to and extend between the side rails at a front end of the deck. Likewise, a rear roller may be rotatably coupled to and extend between the side rails at a rear end of the deck 14. Additionally, a support surface 38 (*see* FIG. 1) may be coupled to and extend between the side rails at a location between the front and rear rollers. The treadmill 16 may be routed around the rollers and the support surface 38, to provide a continuous running surface.

[0038] A rear deck height adjustment mechanism 40 may be located at a rear end of the deck 14. In one embodiment, the rear deck height adjustment mechanism 40 may be rotatably coupled to the side rails of a deck frame 42. The rear deck height adjustment mechanism 40 may comprise a cross-bar 44, and legs 46 extending from the cross-bar. Each leg 46 may include a wheel 48 positioned to contact the floor underlying the treadmill 10.

[0039] A lever arm 50 may extend from a central region of the cross-bar 44 of the rear deck height adjustment mechanism 40. Accordingly, when a force is applied to the lever arm 50 a torque may be applied to the rear deck height adjustment mechanism 40 and the legs 46 of the rear deck height adjustment mechanism 40 may rotate relative to the deck frame 42.

[0040] A first motor 52, for operating the rear deck height adjustment mechanism 40, may be located at the front end of the deck 14. An elongate power transmission device 54 may extend from the first motor 52 to the lever 50 of the rear deck height adjustment mechanism 40. For example, the elongate power transmission device 54 may comprise a screw extending from the first motor 52 located at the front of the deck 14 to the lever 50 of the rear deck height adjustment mechanism 40. A nut may be hinged to the lever 50 of the rear deck height adjustment mechanism 40, and the screw may extend through the nut. Accordingly, helical threads of the screw may be intermeshed with corresponding helical threads of the nut.

[0041] A front deck height adjustment mechanism 60 may be located at a front end of the deck 14. In one embodiment, the front deck height adjustment mechanism 60 may be rotatably coupled to the side rails of the deck frame 42. The front deck height adjustment

Docket Number: 11-054.11.01PCT (59665.0503)

mechanism 60 may comprise a cross-bar 62, and arms 64 extending from the cross-bar 62. Each of the arms 64 may also be rotatably coupled to the frame 12 of the treadmill 10.

[0042] A lever arm 66 may extend from a central region of the cross-bar 62 of the front deck height adjustment mechanism 60. Accordingly, when a force is applied to the lever arm 66 a torque may be applied to the front deck height adjustment mechanism 60 and the arms 64 of the front deck height adjustment mechanism 60 may rotate relative to the deck frame 42 and the frame 12 of the treadmill 10.

[0043] A second motor 68, for operating the front deck height adjustment mechanism 60, may be located at the front end of the deck 14. A power transmission device 70 may extend from the motor 68 to the lever 66 of the front deck height adjustment mechanism 60. For example, a screw may extend from the motor 68 to the lever 66 of the front deck height adjustment mechanism 60. A nut may be hinged to the lever 66 of the front deck height adjustment mechanism 60, and the screw may extend through the nut. Accordingly, helical threads of the screw may be intermeshed with corresponding helical threads of the nut.

[0044] In some embodiments, a lift assist device (not shown), for facilitating the movement of the deck between the operating position and the storage position, may extend between the deck frame 42 and the frame 12 of the treadmill 10.

[0045] For a particular treadmill design, empirical data may be collected by operating the treadmill 10 with users of various weights positioned on the treadbelt 16. Optionally, weight may be incrementally applied to a user positioned on the treadbelt 16 of the treadmill 10 to collect empirical data. While the user is positioned on the treadbelt 16, the treadbelt 16 may be moved by the drive motor 32 and the electrical current utilized by the drive motor 32 may be measured by the sensor 30 and recorded by the computer 24.

[0046] The angle of the deck 14, and thus the treadbelt 16, may be selected that may facilitate distinguishable data signals collected from users of differing weight. For example, the deck 14 angle may be positioned at a decline, simulating a declining slope (*i.e.*, simulating walking downhill).

[0047] In operation, a user may power on the treadmill 10, such as by pressing a button on the console 20, or by inserting a safety key into a receptacle in the console 20. The

Docket Number: 11-054.11.01PCT (59665.0503)

user's feet may be positioned on the treadmill 10 and the treadmill 10 may begin a weight determination procedure.

[0048] To determine the user's weight, the drive motor 32 may drive the treadmill 10 while the user is positioned on the treadmill 10. As the treadmill 10 is driven with the drive motor 32, the user may begin to walk. As a non-limiting example, the treadmill 10 may be driven at a linear speed less than about 2.25 meters per second.

[0049] As the user walks on the treadmill 10, the electric current utilized by the drive motor 32 may be measured with the sensor 30. The measured electric current may then be analyzed by the computer 24 to determine the weight of the user positioned on the treadmill 10 of the treadmill 10.

[0050] In order to collect electric current data that may provide a more accurate and reliable weight determination, the treadmill 10 may be positioned to simulate a slope, such as an inclining slope or a declining slope. Optionally, the slope of the treadmill 10 may be changed while measuring the electric current utilized by the drive motor 32.

[0051] In some embodiments, analyzing the measured electric current to determine the weight of the person positioned on the treadmill 10 of the treadmill 10 may comprise comparing the measured electric current to a value on a lookup table, which may be stored in the memory 28 of the computer 24. In further embodiments, analyzing the measured electric current to determine the weight of the user positioned on the treadmill 10 of the treadmill 10 may comprise inputting the measured electric current into a mathematical function with the computer 24.

[0052] Additionally, an average measured electric current over a period of time may be analyzed to improve accuracy and reliability. The cadence of the user walking on the treadmill 10 may be determined by measuring cyclic features of the data, such as peaks in energy usage. The determined cadence of the user may then be utilized to analyze an average measured electric current, such as an average maximum current (*i.e.*, peak current) or an average minimum current, over a period of time that corresponds to the user's cadence.

[0053] After a user's weight has been automatically determined, the determined weight may be utilized by the computer 24 to calculate calories expended by the user while exercising on the treadmill. The calorie expenditure may then be displayed via the console. Optionally, if the user desires, the determined weight may also be displayed via the console.

Docket Number: 11-054.11.01PCT (59665.0503)

INDUSTRIAL APPLICABILITY

[0054] The weight of a user may be required to utilize various features of a treadmill. For example, the calorie expenditure by a user while exercising on a treadmill may be more accurately estimated by utilizing the weight of the user. In view of this, prior to each use of a treadmill, a user may be required to input their current weight. This may be cumbersome and time consuming to the user, and requires that the user accurately know their current weight. Accordingly, a user may unintentionally input an inaccurate weight.

[0055] Also, it may be embarrassing to a user to enter their weight into a treadmill located in view of others, such as at a fitness club or gym, and disclose their current weight. Thus, the person may intentionally input an inaccurate weight to avoid disclosing their current weight to others. Accordingly, in addition to being a time consuming annoyance to users, requiring a user to enter their current weight via a treadmill console may result in inaccurate and unreliable results.

[0056] To address the foregoing issues, the methods and devices disclosed herein enable the acquisition of the weight of a treadmill user without requiring the user to input their weight manually into the treadmill. Additionally, the methods and devices disclosed herein enable the calculation of a reasonably accurate calorie expenditure by a user on a treadmill without first requesting that the user input their weight manually.

[0057] A treadmill may include a base and a deck having a front end pivotally attached to the base. The deck may include a treadbelt that is exposed at an upper region of the deck and provides a movable, continuous running surface during operation of the treadmill. Additionally, the frame may include one or more handrails to provide support and balance to a user.

[0058] The treadmill may additionally include a console, and the console may include a computer located therein, which may include a processor and a memory. In further embodiments, the computer may not be located in the console, but may be in communication with the console. The computer may be configured to receive data from the inputs of the console and from sensors located about the treadmill.

Docket Number: 11-054.11.01PCT (59665.0503)

[0059] A drive motor may be associated with the treadmill. The drive motor may be positioned and configured to drive the treadmill. For example, the drive motor may be connected to a roller via a drive belt and the treadmill may be positioned over the roller.

[0060] A rear deck height adjustment mechanism may be located at a rear end of the deck, and a front deck height adjustment mechanism may be located at a front end of the deck

[0061] The treadmill may also include one or more sensors for collecting data while a user is running and/or walking on the treadmill of the treadmill. For example, a sensor may be positioned and configured to sense the electrical current utilized by the drive motor. The computer may be configured to receive data from the sensor and to analyze the data with the processor.

[0062] For a particular treadmill design, empirical data may be collected by operating the treadmill with users of various weights positioned on the treadmill. Optionally, weight may be incrementally applied to a user positioned on the treadmill of the treadmill to collect empirical data. While the user is positioned on the treadmill, the treadmill may be moved by the drive motor and the electrical current utilized by the drive motor may be measured and recorded.

[0063] The angle of the deck, and thus the treadmill, may be selected that may facilitate distinguishable data signals collected from users of differing weight. For example, the deck angle may be positioned at a decline, simulating a declining slope (*i.e.*, simulating walking downhill).

[0064] In operation, a user may power on the treadmill, such as by pressing a button on the console, or by inserting a safety key into a receptacle in the console. The user's feet may be positioned on the treadmill of the treadmill and the treadmill may begin a weight determination procedure.

[0065] To determine the user's weight, the drive motor may drive the treadmill while the user is positioned on the treadmill. As the treadmill is driven with the drive motor, the user may begin to walk. As a non-limiting example, the treadmill may be driven at a linear speed less than about 2.25 meters per second.

[0066] As the user walks on the treadmill, the electric current utilized by the drive motor may be measured with the sensor. The measured electric current may then be analyzed

Docket Number: 11-054.11.01PCT (59665.0503)

by the computer to determine the weight of the user positioned on the treadbelt of the treadmill.

[0067] In order to collect electric current data that may provide a more accurate and reliable weight determination, the treadbelt may be positioned to simulate a slope, such as an inclining slope or a declining slope. Optionally, the slope of the treadbelt may be changed while measuring the electric current utilized by the drive motor.

[0068] In some embodiments, analyzing the measured electric current to determine the weight of the person positioned on the treadbelt of the treadmill may comprise comparing the measured electric current to a value on a lookup table, which may be stored in the memory of the computer. In further embodiments, analyzing the measured electric current to determine the weight of the user positioned on the treadbelt of the treadmill may comprise inputting the measured electric current into a mathematical function with the computer.

[0069] Additionally, an average measured electric current over a period of time may be analyzed to improve accuracy and reliability. The cadence of the user walking on the treadbelt may be determined by measuring cyclic features of the data, such as peaks in energy usage. The determined cadence of the user may then be utilized to analyze an average measured electric current over a period of time that corresponds to the user's cadence.

[0070] After a user's weight has been automatically determined, the determined weight may be utilized to calculate calories expended by the user while exercising on the treadmill.

Docket Number: 11-054.11.01PCT (59665.0503)

WHAT IS CLAIMED IS:

1. A method of determining a person's weight, the method comprising:
driving a treadbelt of a treadmill with a drive motor while a person is positioned on the treadbelt;
measuring an electric current utilized by the drive motor; and
analyzing the measured electric current to determine the weight of the person positioned on the treadbelt of the treadmill.
2. The method of claim 1, further comprising positioning the treadbelt to simulate a declining slope.
3. The method of claim 1, further comprising positioning the treadbelt to simulate an inclining slope.
4. The method of claim 1, wherein analyzing the measured electric current to determine the weight of the person positioned on the treadbelt of the treadmill comprises comparing the measured electric current to a value on a lookup table.
5. The method of claim 1, wherein analyzing the measured electric current to determine the weight of the person positioned on the treadbelt of the treadmill comprises inputting the measured electric current into a mathematical function.
6. The method of claim 1, wherein driving the treadbelt of the treadmill with the drive motor while the person is positioned on the treadbelt comprises driving the treadbelt at a linear speed less than about 2.25 meters per second.
7. The method of claim 1, wherein analyzing the measured electric current further comprises analyzing an average measured electric current over a period of time.

Docket Number: 11-054.11.01PCT (59665.0503)

8. The method of claim 7, further comprising determining a cadence of the person positioned on the treadmill.
9. The method of claim 8, wherein analyzing an average measured electric current over a period of time comprises analyzing an average measured electric current over a period of time corresponding to the determined cadence.
10. The method of claim 1, further comprising changing the slope of the treadmill while measuring the electric current utilized by the drive motor.
11. A method of calculating calories expended while exercising on a treadmill, the method comprising:
 - measuring the weight of a person on a treadmill; and
 - utilizing the determined weight to calculate calorie expenditure.
12. The method of claim 11, wherein automatically determining the weight of the person on the treadmill comprises:
 - driving a treadmill of the treadmill with a drive motor while the person is positioned on the treadmill;
 - measuring an electric current utilized by the drive motor; and
 - analyzing the measured electric current to determine the weight of the person positioned on the treadmill of the treadmill.
13. The method of claim 12, further comprising positioning the treadmill to simulate a declining slope.
14. The method of claim 12, wherein analyzing the measured electric current to determine the weight of the person positioned on the treadmill of the treadmill comprises comparing the measured electric current to a value on a lookup table.

Docket Number: 11-054.11.01PCT (59665.0503)

15. The method of claim 12, wherein analyzing the measured electric current to determine the weight of the person positioned on the treadbelt of the treadmill comprises inputting the measured electric current into a mathematical function.

16. The method of claim 12, wherein driving the treadbelt of the treadmill with the drive motor while the person is positioned on the treadbelt comprises driving the treadbelt at a linear speed less than about 2.25 meters per second.

17. The method of claim 12, wherein analyzing the measured electric current further comprises analyzing an average measured electric current over a period of time.

18. The method of claim 17, further comprising determining a cadence of the person positioned on the treadbelt.

19. A treadmill comprising:
a platform;
a treadbelt extending over the platform;
a drive motor positioned and configured to drive the treadbelt;
an electrical current sensor configured to measure the electrical current utilized by the drive motor; and
a computer programmed and configured to analyze measured electrical current usage by the drive motor to determine the weight of a person positioned on the treadbelt.

20. The treadmill of claim 19, further comprising:
a rear deck height adjustment mechanism; and
a front deck height adjustment mechanism.

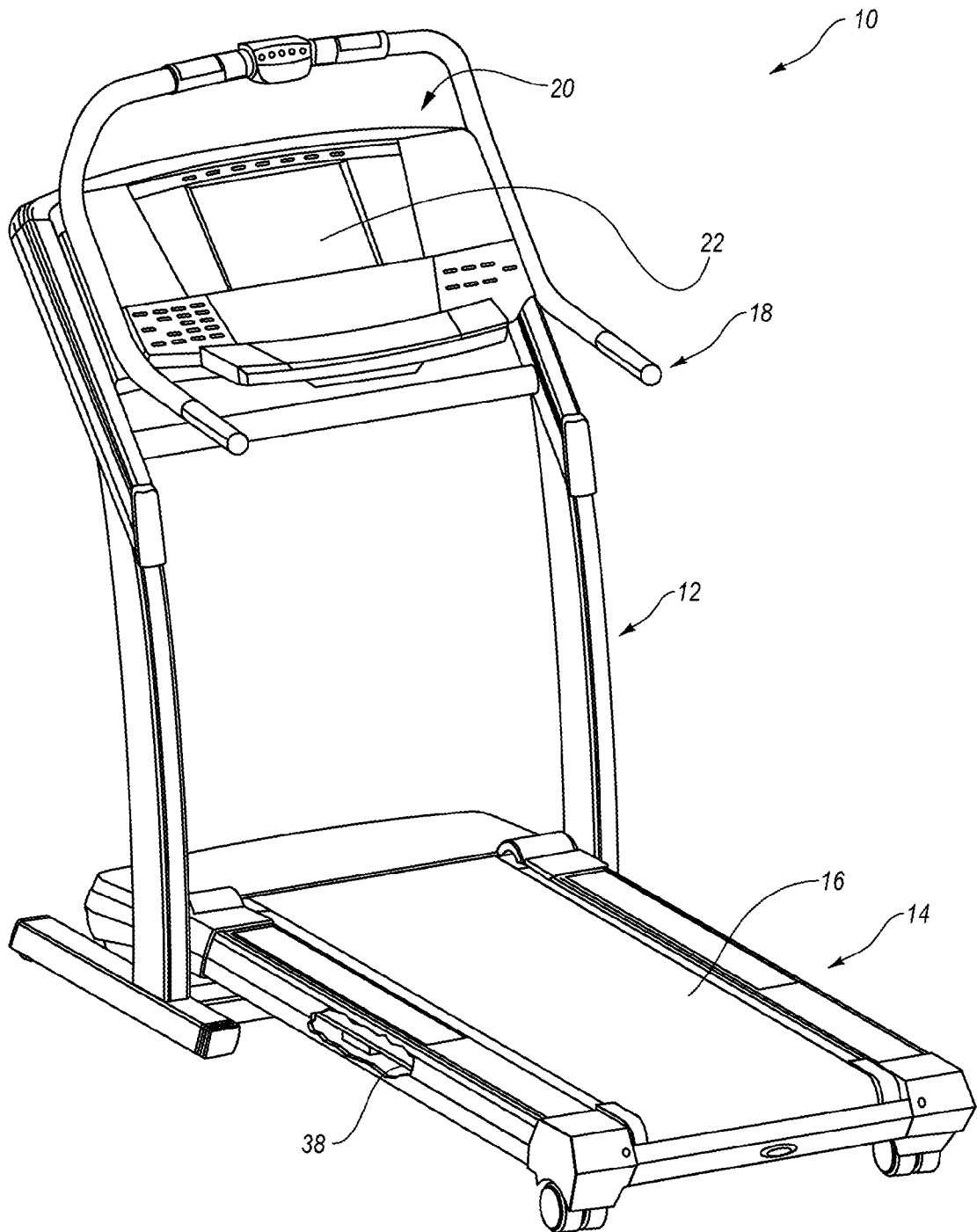

Fig. 1

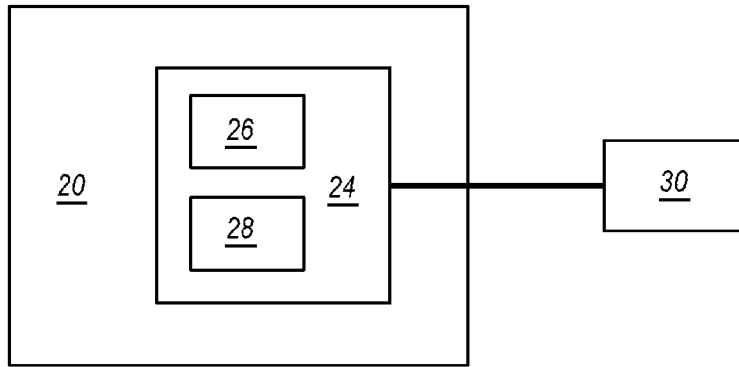

Fig. 2

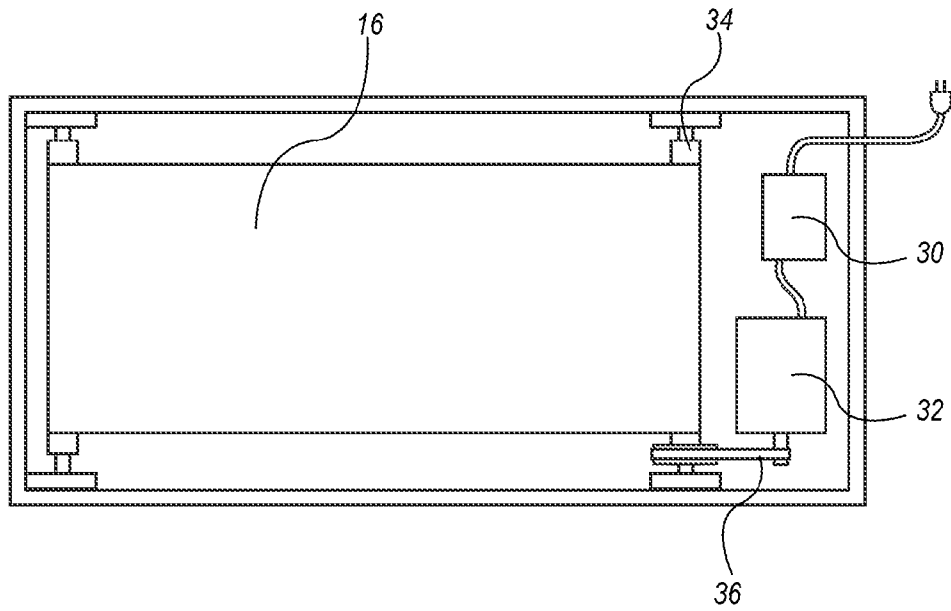

Fig. 3

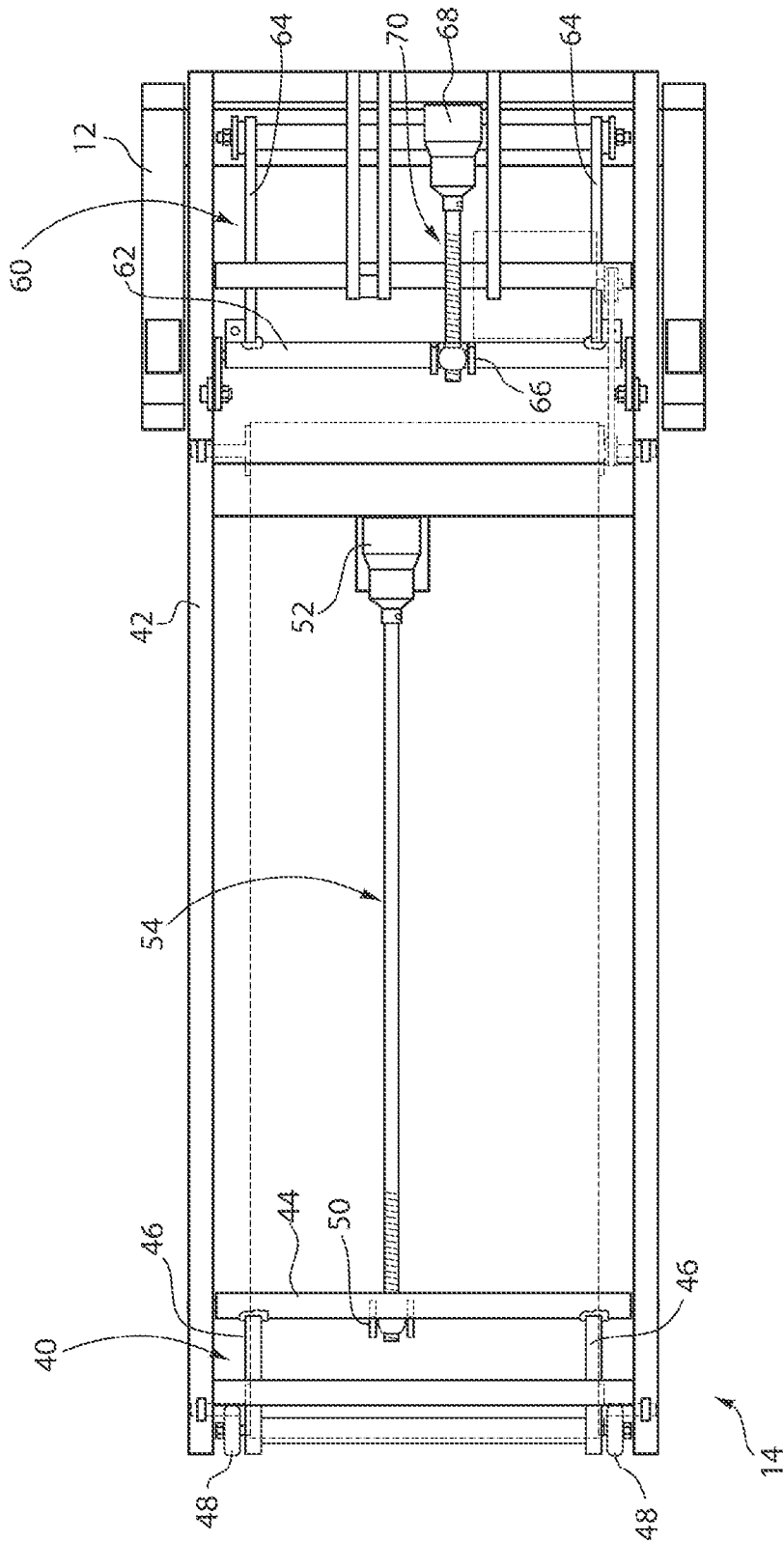

FIG. 4

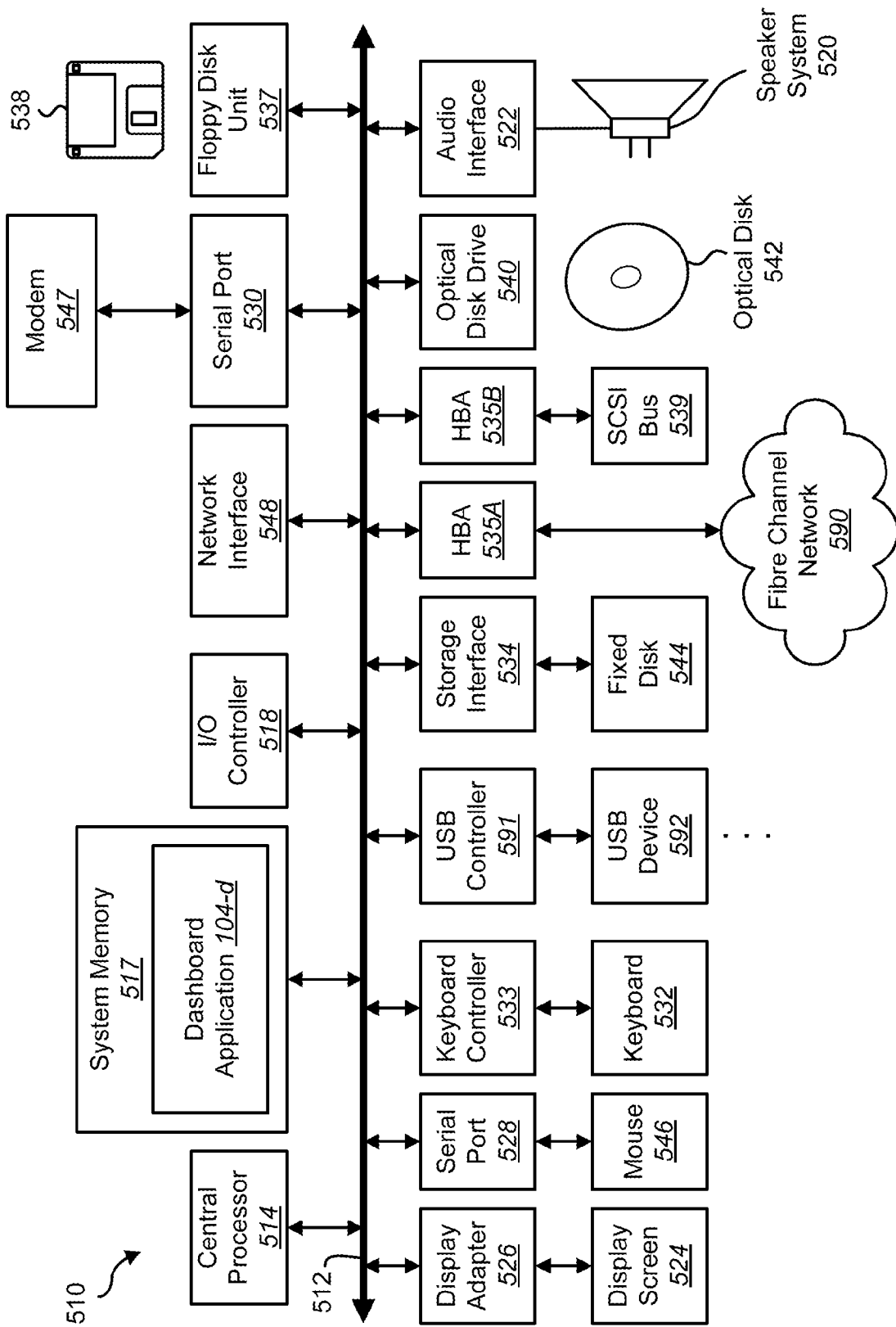

FIG. 5

A. CLASSIFICATION OF SUBJECT MATTER**G01G 19/52(2006.01)i, G01G 19/44(2006.01)i, A63B 22/02(2006.01)i, G01G 7/00(2006.01)i**

According to International Patent Classification (IPC) or to both national classification and IPC

B. FIELDS SEARCHED

Minimum documentation searched (classification system followed by classification symbols)

G01G 19/52; A63B 24/00; A63B 22/02; A63B 22/04; A63B 26/00; A63B 22/00; A63B 71/00; G01G 19/44; G01G 7/00

Documentation searched other than minimum documentation to the extent that such documents are included in the fields searched

Korean utility models and applications for utility models

Japanese utility models and applications for utility models

Electronic data base consulted during the international search (name of data base and, where practicable, search terms used)

eKOMPASS(KIPO internal) & keywords: weight, treadmill, belt, current, slope, incline, deck, average, cadence and motor

C. DOCUMENTS CONSIDERED TO BE RELEVANT

Category*	Citation of document, with indication, where appropriate, of the relevant passages	Relevant to claim No.
X	US 2005-0227820 A1 (DYER et al.) 13 October 2005 See abstract; paragraphs 5, 27-45, 62 and figures 1-9.	1-20
A	US 2010-0216599 A1 (WATTERSON et al.) 26 August 2010 See abstract; paragraphs 61-63 and figures 1-5.	1-20
A	US 2004-0171464 A1 (ASHBY et al.) 02 September 2004 See abstract; paragraphs 25-33 and figures 1-3.	1-20
A	US 2010-0255959 A1 (DALEBOUT et al.) 07 October 2010 See abstract; paragraphs 82-84 and figures 1A-5B.	1-20
A	US 6626803 B1 (OGLESBY et al.) 30 September 2003 See abstract; column 2, line 34 - column 4, line 13 and figures 1-4.	1-20

 Further documents are listed in the continuation of Box C. See patent family annex.

* Special categories of cited documents:

"A" document defining the general state of the art which is not considered to be of particular relevance

"E" earlier application or patent but published on or after the international filing date

"L" document which may throw doubts on priority claim(s) or which is cited to establish the publication date of another citation or other special reason (as specified)

"O" document referring to an oral disclosure, use, exhibition or other means

"P" document published prior to the international filing date but later than the priority date claimed

"T" later document published after the international filing date or priority date and not in conflict with the application but cited to understand the principle or theory underlying the invention

"X" document of particular relevance; the claimed invention cannot be considered novel or cannot be considered to involve an inventive step when the document is taken alone

"Y" document of particular relevance; the claimed invention cannot be considered to involve an inventive step when the document is combined with one or more other such documents, such combination being obvious to a person skilled in the art

"&" document member of the same patent family

Date of the actual completion of the international search

24 July 2014 (24.07.2014)

Date of mailing of the international search report

25 July 2014 (25.07.2014)

Name and mailing address of the ISA/KR

International Application Division
Korean Intellectual Property Office
189 Cheongsu-ro, Seo-gu, Daejeon Metropolitan City, 302-701,
Republic of Korea

Facsimile No. +82-42-472-7140

Authorized officer

AHN, Jae Yul

Telephone No. +82-42-481-8525



INTERNATIONAL SEARCH REPORT

Information on patent family members

International application No.

PCT/US2014/029401

Patent document cited in search report	Publication date	Patent family member(s)	Publication date
US 2005-0227820 A1	13/10/2005	DE 602004013121 D1	29/05/2008
		EP 1584356 A2	12/10/2005
		EP 1584356 A3	10/05/2006
		EP 1584356 B1	16/04/2008
		JP 2005-296649 A	27/10/2005
		US 7507187 B2	24/03/2009
		US 2010-0216599 A1	26/08/2010
AU 2009-303477 A1	20/02/2014		
AU 2009-303477 B2	27/02/2014		
EP 2379178 A1	26/10/2011		
US 2010-0093492 A1	15/04/2010		
US 7713172 B2	11/05/2010		
US 7862475 B2	04/01/2011		
WO 2010-045260 A1	22/04/2010		
US 2004-0171464 A1	02/09/2004	AU 2003-285051 A1	28/09/2004
		WO 2004-078281 A1	16/09/2004
US 2010-0255959 A1	07/10/2010	CN 101203281 A	18/06/2008
		CN 101203281 B	27/10/2010
		EP 1917077 A2	07/05/2008
		US 2006-0035755 A1	16/02/2006
		US 2006-0287161 A1	21/12/2006
		US 2007-0129218 A1	07/06/2007
		US 2008-0153674 A9	26/06/2008
		US 2008-0167163 A9	10/07/2008
		US 7740563 B2	22/06/2010
		US 7766797 B2	03/08/2010
		US 7775940 B2	17/08/2010
		US 7909740 B2	22/03/2011
		WO 2006-138601 A2	28/12/2006
		WO 2006-138601 A3	18/05/2007
US 6626803 B1	30/09/2003	CA 2317842 A1	07/03/2001
		CA 2317842 C	20/06/2006
		CA 2317857 A1	07/03/2001
		CA 2317857 C	22/08/2006
		CA 2317859 A1	07/03/2001
		CA 2317859 C	26/04/2005
		CA 2357096 A1	07/03/2002
		CA 2357096 C	28/11/2006
		CA 2357119 A1	07/03/2002
		CA 2357119 C	20/06/2006
		CA 2503334 A1	07/03/2001
		CA 2503334 C	15/11/2005
		CA 2503386 A1	07/03/2001
		CA 2503386 C	15/11/2005
		CA 2505877 A1	07/03/2001

INTERNATIONAL SEARCH REPORT

Information on patent family members

International application No.

PCT/US2014/029401

Patent document cited in search report	Publication date	Patent family member(s)	Publication date
		CA 2505877 C	06/12/2005
		CA 2512601 A1	07/03/2002
		CA 2512601 C	21/11/2006
		CA 2544430 A1	07/03/2001
		CA 2544430 C	18/09/2007
		CA 2572408 A1	07/03/2001
		CA 2572408 C	23/10/2007
		CA 2572545 A1	07/03/2001
		CA 2572545 C	05/02/2008
		DE 60017654 D1	03/03/2005
		DE 60038065 D1	27/03/2008
		DE 60043714 D1	04/03/2010
		EP 1084735 A2	21/03/2001
		EP 1084735 A3	20/06/2001
		EP 1084735 B1	26/01/2005
		EP 1086721 A2	28/03/2001
		EP 1086721 A3	13/06/2001
		EP 1086721 B1	03/08/2005
		EP 1086722 A2	28/03/2001
		EP 1086722 A3	20/06/2001
		EP 1086722 B1	26/01/2005
		EP 1186321 A1	13/03/2002
		EP 1186321 B1	13/05/2009
		EP 1188460 A1	20/03/2002
		EP 1188460 B1	16/02/2011
		EP 1512437 A1	09/03/2005
		EP 1512437 B1	06/06/2007
		EP 1512438 A2	09/03/2005
		EP 1512438 A3	23/03/2005
		EP 1512438 B1	13/02/2008
		EP 1514584 A2	16/03/2005
		EP 1514584 A3	23/03/2005
		EP 1514584 B1	13/01/2010
		US 2002-0045517 A1	18/04/2002
		US 2002-0049121 A1	25/04/2002
		US 2003-0199366 A1	23/10/2003
		US 2005-0026750 A1	03/02/2005
		US 2005-0209062 A1	22/09/2005
		US 2006-0160667 A1	20/07/2006
		US 2007-0161466 A1	12/07/2007
		US 6443875 B1	03/09/2002
		US 6572512 B2	03/06/2003
		US 6776740 B1	17/08/2004
		US 6783482 B2	31/08/2004
		US 6899659 B2	31/05/2005
		US 7115076 B2	03/10/2006
		US 7179204 B2	20/02/2007
		US 7846070 B2	07/12/2010