



- (51) **International Patent Classification:**  
*B60L 11/18* (2006.01)    *H02M 7/23* (2006.01)  
*H02J 7/00* (2006.01)
- (21) **International Application Number:** PCT/EP2012/050813
- (22) **International Filing Date:** 19 January 2012 (19.01.2012)
- (25) **Filing Language:** English
- (26) **Publication Language:** English
- (30) **Priority Data:** 11151395.8    19 January 2011 (19.01.2011)    EP
- (71) **Applicant: POWER RESEARCH ELECTRONICS B. V.** [NL/NL]; Beneluxweg 45, NL-4904 SJ Oosterhout (NL).
- (72) **Inventors; and**
- (75) **Inventors/Applicants (for US only): KARDOLUS, Menno** [NL/NL]; Basilicumhof 24, NL-1115 DL Duivendrecht (NL). **SCHIJFFELEN, Jos H.** [NL/NL]; Meerten Verhoffstraat, NL-4811 AR Breda (NL). **GRÖNINGER, Mark** [NL/NL]; Schwarzenbergstraat 17, NL-5915 AV Venlo (NL). **VAN CASTEREN, Dolf** [NL/NL]; Koolzaadpad 31, NL-5632 KK Eindhoven (NL).
- (74) **Agent: TER MEER STEINMEISTER & PARTNER, GBR;** Artur-Ladebeck-Str. 51, 33617 Bielefeld (DE).
- (81) **Designated States (unless otherwise indicated, for every kind of national protection available):** AE, AG, AL, AM, AO, AT, AU, AZ, BA, BB, BG, BH, BR, BW, BY, BZ, CA, CH, CL, CN, CO, CR, CU, CZ, DE, DK, DM, DO, DZ, EC, EE, EG, ES, FI, GB, GD, GE, GH, GM, GT, HN, HR, HU, ID, IL, IN, IS, JP, KE, KG, KM, KN, KP, KR, KZ, LA, LC, LK, LR, LS, LT, LU, LY, MA, MD, ME, MG, MK, MN, MW, MX, MY, MZ, NA, NG, NI, NO, NZ, OM, PE, PG, PH, PL, PT, QA, RO, RS, RU, RW, SC, SD, SE, SG, SK, SL, SM, ST, SV, SY, TH, TJ, TM, TN, TR, TT, TZ, UA, UG, US, UZ, VC, VN, ZA, ZM, ZW.
- (84) **Designated States (unless otherwise indicated, for every kind of regional protection available):** ARIPO (BW, GH, GM, KE, LR, LS, MW, MZ, NA, RW, SD, SL, SZ, TZ, UG, ZM, ZW), Eurasian (AM, AZ, BY, KG, KZ, MD, RU, TJ, TM), European (AL, AT, BE, BG, CH, CY, CZ, DE, DK, EE, ES, FI, FR, GB, GR, HR, HU, IE, IS, IT, LT, LU, LV, MC, MK, MT, NL, NO, PL, PT, RO, RS, SE, SI, SK, SM, TR), OAPI (BF, BJ, CF, CG, CI, CM, GA, GN, GQ, GW, ML, MR, NE, SN, TD, TG).
- Published:**  
— *without international search report and to be republished upon receipt of that report (Rule 48.2(g))*



WO 2012/098202 A2

(54) **Title:** BATTERY CHARGER FOR ELECTRIC VEHICLES

(57) **Abstract:** A battery charger (B1) for electric vehicles, composed of at least three identical current controlled AC-DC converter modules (M1, M2, M3) having reverse current protected outputs connected in parallel to a charge terminal of the battery (44).

## BATTERY CHARGER FOR ELECTRIC VEHICLES

The invention relates to a battery charger for electric vehicles.

5 Known battery chargers for electric vehicles are either configured as onboard chargers adapted to be built in on board of the vehicle or as stationary fast chargers installed in a power station. Onboard chargers can be plugged to a single phase 230V-16A mains power socket at the home of the user so that the battery may be charged overnight with a charging power in the order of magnitude of 3.5 kW. Fast chargers are typically powered by a 3-phase 400 V-40A mains source and may have a charging power of several  
10 tens of kW so as to charge the battery to 80-100% of its full capacity in a time of 10 to 30 min. They require a car connection, e. g. according to the specifications of the CHAdeMo standard for electric cars (<http://chademo.com/>).

Both types of battery chargers require the use of high quality electronic components that can withstand high voltages and high currents and are therefore relatively expensive.

15 It is an object of the invention to provide a reliable battery charger that can be manufactured at low costs.

In order to achieve this object, the battery charger according to the invention is composed of at least three identical current controlled AC-DC converter modules having reverse current protected outputs connected in parallel to a charge terminal of the battery.  
20

Since the converter modules are current controlled while the output voltages of all modules are determined by the battery voltage and are thus equal, it is possible to connect the outputs together, so that the charge current into the battery will be the sum of the currents provided by the individual modules. Thus, the modules may be designed for  
25 lower peak currents, so that less expensive components may be used. Since each charger consists of a plurality of modules, mass production of the modules leads to further cost reductions. The output of each module is protected, e. g., by a diode, so that destructive reverse currents can reliably be avoided in case of a failure of one of the modules.

More specific optional features of the invention are indicated in the dependent claims.

Preferably, modules which have an identical basic layout are used for both, onboard chargers and fast chargers, the higher power of the fast charger being achieved by combining a larger number of modules.

5 In a preferred embodiment, even the onboard charger has a modular construction and is composed of three modules. These three modules may be connected in parallel to a 230 V single phase AC voltage but may also be connected to a three-phase voltage source. In the latter case, the input sides of the modules will be connected to the three phases in a triangle configuration, so that each module will be driven by a 400 V AC  
10 voltage. On the one hand, this permits to operate the onboard charger with higher power and, consequently, to shorten the battery charge time when a three-phase power source is available in the household. On the other hand, a plurality of such units each of which is formed by three modules may be combined to form a stationary fast charger powered from a 3-phase source.

15 In a preferred embodiment, the converter modules are formed by resonant converters the output current of which may be controlled over a large control range by varying the switching frequency and/or the switching pattern of switches which excite the resonance circuit of the converter.

20 Since the efficiency of a resonant converter is highest when it is operated close to the resonance frequency, i.e. at maximum power, it is preferred that the output current is roughly adapted to the demand by varying the number of active modules of the charger, and fine-tuning of the output current to the demand is achieved by operating only one of the modules at reduced power whereas all the other active modules are operated at full power.

25 In case that one of the modules should fail, it is possible to generate a signal that indicates the still available power of the remaining modules to a battery controller that controls the charge process of the battery, so that the charge process may be continued with reduced power.

Embodiments of the invention will now be described in conjunction with the drawings, wherein:

- Fig. 1 is a circuit diagram of a power converter module;
- 5 Fig. 2 shows waveforms for explaining the function of the power converter module shown in Fig. 1;
- Fig. 3 shows waveforms illustrating a mode of operation with reduced output current;
- Fig. 4 is a block diagram of a controller for controlling switches of the converter module shown in Fig. 1;
- 10 Figs. 5 and 6 show waveforms illustrating different modes of operation of the converter module;
- Fig. 7 is a block diagram of a converter unit composed of three converter modules and configured as an onboard battery charger;
- 15 Fig. 8 shows a power supply circuit for the converter modules of the unit shown in Fig. 7;
- Fig. 9 is a schematic cross-sectional view of the converter unit;
- Fig. 10 is a diagram illustrating a method of controlling the output currents of the converter modules of the unit shown in Figs. 7 to 9;
- 20 Fig. 11 a block diagram of a fast charger composed of a plurality of units of the type illustrated in Figs. 7 to 9;
- Fig. 12 a diagram illustrating a method of controlling the output currents of the units composing the fast charger;
- Fig. 13 a block diagram of a fast charger according to another embodiment; and

Fig. 14 a diagram illustrating a method of controlling the output currents of the units composing the fast charger shown in Fig. 13.

At first, referring to Figs. 1 to 6, an example of a resonant converter will be described  
5 which may be used as a converter module M1 in a battery charger according to the invention.

As is shown in Fig. 1, the resonant converter module M1 is arranged to convert an input  
voltage  $U_{in}$  into a DC output voltage  $U_{out}$  which will be equal to the battery voltage. The  
input voltage  $U_{in}$  is a DC voltage or a pulsating DC voltage supplied by a voltage source  
10 12.

A resonant tank 14 is formed by an inductor  $L_r$  and two capacitors  $C_{r1}$  and  $C_{r2}$  and is  
connected to the voltage source 12 via a half bridge 16 formed by switches  $Q_1$  and  $Q_2$ .  
The switches  $Q_1$  and  $Q_2$  are electronic switches, e.g. IGBTs. The gates of these switches  
are connected to an electronic module controller 18 (Fig. 4) that will be described later.  
15 A snubber capacitor  $C_{s1}$ ,  $C_{s2}$  is connected in parallel to each of the switches  $Q_1$  and  $Q_2$ .

The switches are alternately opened and closed at a switching frequency in the order  
of magnitude from 25 kHz to 50 kHz so as to cause the resonance tank 14, which may  
have a resonance frequency of 25 kHz, for example, to oscillate. The capacitance com-  
ponents of the resonance tank 14 are formed by the capacitors  $C_{r1}$  and  $C_{r2}$  which are  
20 arranged symmetrically with respect to the inductor  $L_r$ , just as the switches  $Q_1$  and  $Q_2$ .  
The capacitor  $C_{r1}$  is connected between the plus pole of the voltage source 12 and the  
inductor  $L_r$ , and the capacitor  $C_{r2}$  is connected between the inductor  $L_r$  and the minus  
pole of the voltage source.

Two capacitors  $C_2$  and  $C_3$  with equal capacity are connected in series between the plus  
25 and minus poles of the voltage source 12, in parallel with the resonance tank 14. When  
the resonance tank oscillates, a voltage  $U_r$  at the point connecting the inductor  $L_r$  to the  
capacitors  $C_2$  and  $C_3$  will oscillate around a centre voltage that is defined by the mid-  
point between the capacitors  $C_2$  and  $C_3$ . The voltage  $U_r$  drives the primary side of a  
transformer T the secondary side of which is connected to a rectifier 20 formed by a

diode full bridge D and capacitor C<sub>4</sub>. The voltage drop across the capacitor C<sub>4</sub> forms the output voltage U<sub>out</sub>. When a load (battery) is connected, a discharge circuit for the capacitor C<sub>4</sub> is closed, and an output current I<sub>out</sub> may flow to charge the battery.

When the switch Q<sub>1</sub> is ON while the switch Q<sub>2</sub> is OFF, an input current I<sub>in</sub> will flow  
5 through the switch Q<sub>1</sub> and the inductor L<sub>r</sub> to charge the capacitor C<sub>r2</sub>. As long as the voltage drop across the inductor L<sub>r</sub> is positive ( $U_{in} > U_r$ ), a current I<sub>r</sub> in the resonance tank 14 will increase, and the capacitor C<sub>r1</sub> will be discharged. When capacitor C<sub>r1</sub> has been discharged completely, the inductor L<sub>r</sub> will cause the current I<sub>r</sub> to continue, so that  
10 capacitor C<sub>r2</sub> will be charged further and capacitor C<sub>r1</sub> will be charged with opposite polarity. The voltage drop across inductor L<sub>r</sub> becomes negative and the current I<sub>r</sub> decreases. Eventually, the current I<sub>r</sub> will change sign. Then, the switch Q<sub>1</sub> is switched OFF and switch Q<sub>2</sub> is switched ON, so that the capacitors C<sub>r1</sub> and C<sub>r2</sub> will be discharged via the inductor L<sub>r</sub> and the switch Q<sub>2</sub>. The current will increase until the capacitor C<sub>r2</sub> is  
15 discharged, and then the current will gradually drop to zero while the voltage U<sub>r</sub> becomes negative relative to the minus pole of the voltage source 12. Then, the switch Q<sub>2</sub> will be switched off and switch Q<sub>1</sub> will be switched ON again, so that another cycle may start. In this way, a primary current in the transformer T is kept oscillating. When the switching frequency of the switches Q<sub>1</sub> and Q<sub>2</sub> is close to the resonance frequency of the resonance tank 14, a maximum of power will be transferred.

20 In order to prevent the voltage source 12 from being short-circuited via the switches Q<sub>1</sub> and Q<sub>2</sub>, the ON periods of these switches must always be separated by a certain minimum dead time. During these dead times, currents that would otherwise flow through the switches will be diverted into the snubber capacitors C<sub>s1</sub>, C<sub>s2</sub> and, to a smaller part, into the device capacitances of the IGBTs.

25 Fig. 2(A) illustrates the sequence of ON and OFF periods of the switches Q<sub>1</sub> and Q<sub>2</sub>. In this example, the ON periods are separated by dead times T<sub>d</sub> which, for reasons that will become clear below, are larger than the minimum dead time mentioned above.

Fig. 2(B) illustrates a waveform of a voltage U<sub>s</sub> that is sensed by a voltage sensor 22  
(Fig. 1) at the junction point between the two switches Q<sub>1</sub> and Q<sub>2</sub>. Thus, the voltage U<sub>s</sub>  
30 corresponds to the voltage drop across the switch Q<sub>2</sub> whereas U<sub>in</sub> - U<sub>s</sub> represents the

voltage drop across the switch  $Q_1$ . As a consequence of the symmetry of the circuit shown in Fig. 1, the waveform of the voltage  $U_s$  shown in Fig. 2(B) is point-symmetric.

Fig. 2(C) shows the voltage  $U_r$  of the resonance tank. In resonance, this voltage is delayed by  $90^\circ$  relative to the voltage  $U_s$ .

- 5 Fig. 2(D) shows the current  $I_r$  in the resonance tank. This current is  $90^\circ$  ahead of the voltage  $U_r$  and is thus at least approximately in phase with the (non-sinusoidal) waveform of the voltage  $U_s$ .

At the time  $t_1$  in Figs. 2(A)-(D), the switch  $Q_1$  is ON, while the switch  $Q_2$  is OFF. The current  $I_r$  is supplied by the closed switch  $Q_1$ , and the voltage  $U_r$  increases. At the time  
10  $t_2$ , the voltage  $U_r$  has reached its maximum and, accordingly, the current  $I_r$  crosses zero. At this instant, the switch  $Q_1$  is switched OFF. This zero current switching of the switch  $Q_1$  has the advantage that the detrimental effects of tail currents in the IGBT switch  $Q_1$  are largely avoided.

The voltage  $U_s$  which had been clamped to  $U_{in}$  is now allowed to drop, as shown in Fig.  
15 2(B). If the junction point between the switches  $Q_1$  and  $Q_2$  were not connected to the resonance tank 14, the series connection of capacitors  $C_{s1}$  and  $C_{s2}$  would reach an equilibrium, and  $U_s$  would drop to  $U_{in}/2$ . However, the snubber capacitors  $C_{s1}$  and  $C_{s2}$  form another oscillating circuit with the inductor  $L_r$ , and this oscillating circuit tends to discharge  $C_{s2}$  further. Ideally,  $U_s$  would therefore drop to zero.

20 In order to reduce switching losses, the dead time  $T_d$  should be selected such that the switch  $Q_2$  is switched ON in the very moment when  $U_s$  reaches zero because, then, no energy that has been stored in the capacitor  $C_{s2}$  would be dissipated when this capacitor is short-circuited. In practice, however,  $U_s$  may not always reach exactly zero, because the oscillating circuit is subject to external influences such as fluctuations of the input  
25 voltage  $U_{in}$  and changes of the load conditions. This is why the desirable zero voltage switching cannot always be achieved. What can be achieved, however, is a so-called valley switching, i.e. the switch  $Q_2$  is switched ON when  $U_s$  (the absolute value thereof) reaches a minimum. The exact timing  $t_3$  when this condition is fulfilled will also depend

upon the external influences mentioned above and may therefore vary for varying operating conditions of the converter.

At the time  $t_4$ , the switch  $Q_2$  will be switched OFF again (zero current switching at resonance), and the discharge process of the capacitor  $C_{s1}$  between  $t_4$  and  $t_5$  is the mirror  
5 image of the process between  $t_2$  and  $t_3$ . At  $t_5$ , the switch  $Q_1$  is switched ON again (valley switching for  $Q_1$ ) and another cycle will start.

In this converter module, the module controller 18 (Fig. 4) is configured to determine the ON switching timings  $t_3$  and  $t_5$  on the basis of the actual value of the voltage  $U_s$  as measured by the voltage sensor 22, so that the ZVS condition or at least the valley  
10 switching condition can be fulfilled even under varying operating conditions of the converter.

In the example that is described here, the switching frequency of the switches  $Q_1$  and  $Q_2$  is varied in order to comply with varying demands for output current  $I_{out}$ . For example, the switching frequency may vary in an a range between 25 kHz and 50 kHz.

15 Figs. 3(A)-(C) show waveforms for a mode of operation in which the converter operates above resonance. Since the dead times  $T_d$  are determined by the valley switching condition, an increase of the switching frequency means that the duty cycle of the ON periods of the switches  $Q_1$  and  $Q_2$  becomes shorter, as can be seen by comparing Fig. 3(B) to Fig. 2(A). The switching frequency is determined by a clock signal CLK the waveform  
20 of which is shown in Fig. 3(A). The timings of the clock pulses correspond to the OFF switching timings  $t_2$  and  $t_4$  in Fig. 2, i.e. the clock pulses alternately trigger the OFF switching operations of the switches  $Q_1$  and  $Q_2$ . The ON-switching operations will then be determined by the valley switching criterion.

Fig. 3(C) shows the voltage  $U_r$  of the resonance tank for the off-resonance mode. Since  
25 the switching frequency is higher than the resonance frequency, the phase delay of the voltage  $U_r$  is larger than  $90^\circ$ , and the amplitude is smaller, so that less power is transferred to the output side. The shortened duty cycles of the switches  $Q_1$  and  $Q_2$  will also contribute to the reduced power transfer (and also to a decrease of the input current  $I_{in}$ ).

The module controller 18 will now be described in greater detail by reference to Fig. 4.

In this example, the voltage source 12 is formed by a power supply having a diode full bridge 12a for rectifying an AC grid voltage  $U_{\text{grid}}$ . To achieve a high power factor on the input side, the converter has power factor correction functionality. Accordingly, the input (filter) capacitance is selected as small as possible. Thus, in this example, the input voltage  $U_{\text{in}}$  for the converter module M1 has a waveform composed of sinusoidal positive half waves.

The converter module M1 is current controlled, i.e. the output current  $I_{\text{out}}$  is controlled to a given target value designated by a demand signal  $I_{\text{out setpoint}}$  that is supplied to the module controller 18. The actual output current  $I_{\text{out}}$  is measured by a current sensor 24 and is delivered to the module controller 18 as a feedback signal.

A main unit 26 of the module controller 18 compares the output current  $I_{\text{out}}$  to the demand signal  $I_{\text{out setpoint}}$  and generates a command signal  $\text{Cmd}$  that is supplied to a multiplier 28. A voltage sensor 30 detects the input voltage  $U_{\text{in}}$  and sends a signal representing this input voltage to another input of the multiplier 28. The product of the command signal  $\text{Cmd}$  and the input voltage  $U_{\text{in}}$  is supplied to a sub-unit 32 of the module controller 18 as a reference signal  $I_{\text{in ref}}$ . The sub-unit 32 compares this reference signal to the input current  $I_{\text{in}}$  that is detected by a current sensor 34. As a comparison result, the sub-unit 32 outputs a frequency signal  $f$  to a clock generator 36. This clock generator further receives a synchronizing signal  $\text{sync}$  that is derived from the input voltage  $U_{\text{in}}$  and generates the clock signal  $\text{CLK}$  with the frequency  $f$  and synchronized with the pulsating input voltage  $U_{\text{in}}$  and, indirectly, with the grid voltage  $U_{\text{grid}}$ .

The clock signal  $\text{CLK}$  is supplied to a switch controller 38 which further receives the voltage  $U_{\text{s}}$  as sensed by the voltage sensor 22 and controls the gates of the switches  $Q_1$  and  $Q_2$ . For example, the switch controller 38 may determine the ON-timings by monitoring both, the absolute value and the time derivative of  $U_{\text{s}}$ . Thus, in a normal mode of operation, the switch controller 38 controls the OFF-timings of the switches  $Q_1$  and  $Q_2$  on the basis of the clock signal  $\text{CLK}$  and the ON timings of the switches on the basis of the sensed voltage  $U_{\text{s}}$ . The synchronisation of the clock signal  $\text{CLK}$  with the grid voltage has the advantage that undesirable interferences between the switching frequency and the grid frequency (50 Hz) are avoided and EMI is reduced.

The frequency of the clock signal CLK is varied in order to control both, the output current  $I_{out}$  and the input current  $I_{in}$ . In an inner feedback loop comprising the sub-unit 32, the input current  $I_{in}$  is controlled so as to preserve the sinusoidal waveform of the input current (power factor correction). The frequency of the clock signal CLK is controlled  
5 as to cause the input current  $I_{in}$  to follow the reference value  $I_{in\ ref}$  which is the product of  $U_{in}$  and the constant (or slowly varying) command signal Cmd, so that  $I_{in}$  is forced to be in phase with and to have the same sinusoidal half waves as  $U_{in}$ .

The amplitude of the half waves of  $I_{in}$  is determined by the command signal Cmd which is varied in an outer feedback loop comprising the main unit 26 and causing the output  
10 current  $I_{out}$  to follow the demand as specified by the demand signal  $I_{out\ setpoint}$ .

The switch controller 38 has different modes of operation selectable by means of a mode signal Mod delivered by the main unit 26. For example, since the clock signal CLK determines only the OFF timings of the switches  $Q_1$  and  $Q_2$  and the ON timings are determined by the valley switching criterion, it is clear that a start mode should be  
15 provided for delivering the first or the first few ON pulses to the switches  $Q_1$  and  $Q_2$  until the converter has started to resonate and a meaningful voltage  $U_s$  can be derived. In a preferred embodiment, valley switching is only allowed in a pre-defined time window. If valley switching fails, outside the normal operation conditions, the switches are forced to switch on.

20 When the demand represented by  $I_{out\ setpoint}$  decreases, the switching frequency  $f$  may be increased so as to reduce the output current  $I_{out}$  accordingly. However, when the setpoint is decreased further, a point will be reached where the switching frequency must be so high that even with the converter that is proposed here the residual switching losses would become predominant. This is why the switch controller 38 has additional modes  
25 of operation which permit to reduce the output current even beyond this point.

Fig. 5 illustrates, on a reduced time scale, the sequence of ON and OFF pulses of the switches  $Q_1$  and  $Q_2$  for a mode of operation in which the power transfer is reduced by periodically skipping isolated ones of the ON pulses of both switches. In the example shown, one out of four ON-pulses of both switches is skipped, so that the power transfer  
30 will be reduced by 25%. The timings at which the ON-pulses of the two switches are

skipped are offset relative to one another, which helps the resonance tank to stay in the resonant mode. Although random pulse skipping would be possible, it is preferred to use pre-defined regular pulse skipping patterns in order avoid random pulse cancellation and sub-harmonic output current variations.

5 Fig. 6 illustrates, on an even further reduced time scale, a mode of operation, wherein the sequence of ON pulses of both switches is chopped into bursts 40 that are separated by breaks 42. In practice, the number of pulses per burst will be significantly larger than shown in Fig. 6, large enough for the resonance tank to tune-in, and the breaks 42 may be so large that the resonance oscillations may decay until the next burst begins. In this way, the power transfer may be reduced to 50% or even less. Yet, given that the switching frequency may be as high as 50 kHz, the repeat frequency of the bursts 40 may be so large that the resulting ripple in the output current will be negligible.

Of course, it is also possible to combine the pulse skipping mode of Fig. 5 with the burst mode of Fig. 6 in order to reduce the power transfer even further. Moreover it is possible to vary the ratio between the skipped and the non-skipped pulses in the pulse skip mode and/or to vary the ratio between the length of the bursts and the length of the breaks in the burst mode, and all this may additionally be combined with frequency control. For example, when switching from one mode to another, the converter frequency may be set to a pre-defined value, based on a frequency table or a suitable algorithm, so as to prevent a momentary step in the output current during the transition.

A first embodiment of a battery charger will now be described by reference to Figs. 7 to 10.

As is shown in Fig. 7, three converter modules M1, M2 and M3, each of which may have the design that has been described above, are connected together to form a converter unit B1 which, in this embodiment, serves as an onboard battery charger for a battery 44 of an electric vehicle. The positive output terminal of each converter module is connected to the anode of a diode 46. The cathodes of all three diodes 46 are commonly connected to the plus terminal of the battery 44. The minus terminal of the battery is connected to the negative output terminals of each of the converters M1, M2, M3. Thus, when all three converter modules are operating, the battery 44 will be

charged with a current that is the sum of the output currents of the three converters. The winding ratios of the transformers T in the converter modules M1 - M3 are selected such that the output voltages of all modules correspond to the nominal battery voltage.

5 A battery controller 48 monitors the relevant state parameters of the battery 44, including the charge current, the actual voltage and the temperature of the battery, and controls the battery charge operation by sending a demand signal  $I_t$  (representing a target charge current) to a board controller 50 of the converter unit B1. The board controller 50 controls the three converters M1- M3 and, in particular, sends a demand signal (corresponding to  $I_{out \text{ setpoint}}$  in Fig. 4) to the module controller 18 of each converter  
10 module.

10 A reverse current detector 52 is arranged between the diodes 46 and the battery 44 for detecting a current flowing in reverse direction, i.e. from the battery towards the converter modules, in case of a failure of one of the converters and the associated diode 46. In case of such a reverse current, the board controller 50 will disable all converter modules.

15 As an alternative, the reverse current sensor 52 may be replaced by another diode protecting the battery against reverse currents, or reverse current detectors may be provided between the output terminal of each converter and the associated diode 46 (in this case, the function of the reverse current detector could be taken over by the output current detector 24 shown in Fig. 4).

20 The three converter modules M1- M3 and the board controller 50 of the unit B1 may be formed on a common printed circuit board 54 (Fig. 9) that is mounted on a water cooled base plate 56. In Fig. 7, the water cooling system for the converter unit B1 has been symbolized by a coolant line 58. Another coolant line 60 is provided for cooling the battery 44 (especially when the vehicle is running and the battery is discharged). The  
25 coolant lines 58 and 60 are connected to an outlet port of a pump 62 via a two way valve 64. The pump 62 sucks the coolant water from a reservoir 66 into which the water is recirculated via the lines 58, 60. A pump driver 68 is arranged to control the operation of the pump 62 based on command signals received from the board controller 50 and/or the battery controller 48. The board controller 50 further controls the valve 64, so that a  
30 sufficient amount of water may be circulated through the coolant line 58 while the bat-

tery 44 is charged. When the battery charger is not operating, the valve 64 is switched to a state in which it connects the pump 62 only to the coolant line 60 for the battery.

Fig. 8 is a circuit diagram for a power supply circuit for the converter unit B1 shown in Fig. 7. When the onboard battery charger is connected to a three-phase mains socket by a suitable plug, the voltages of the three phases will be carried on conductors L1, L2 and L3. These conductors are connected in a triangle configuration to diode full bridges 70, 72 and 74, so that each full bridge will rectify a 400 V phase-against-phase AC voltage and supply the resulting rectified voltage (pulsating DC voltage) to the input side of one of the converters M1, M2 and M3. Since the three input voltages are phase-shifted by  $120^\circ$ , the sum of the output currents of the three converter modules will have only a little amount of ripple, even when the input voltages of the three converter modules are not smoothed by capacitors. In this way, it is possible to suppress the ripple in the battery charge current to a level that is tolerable for the battery.

On the other hand, when the battery charger is connected to a single phase mains socket by a suitable plug, a single phase mains voltage (230 V) will develop between the conductor L1 and a neutral conductor N, whereas conductors L2 and L3 are idle. An input mode selector 76 detects the voltages on the conductors L1, L2 and L3 and when a voltage is detected only on conductor L1, the mode selector closes switches S1 and S2 so as to switch the power supply circuit to a single phase mode. In this mode, the voltage on conductor L1 against the neutral conductor N is rectified for the converter module M1 by two of the diodes of the full bridge 70 and two further diodes 78, 80 (these four diodes forming a full bridge). Similarly, two of the diodes of the full bridge 72 and two further diodes 82, 84 form a rectifier full bridge for the converter module M2. Another diode full bridge 86 rectifies the L1-against-N voltage for the converter module M3. Since, in this case, all three rectifiers are connected in parallel between L1 and N, the ripple in the charge current may be somewhat larger. On the other hand, since the converter modules operate only at 230 V input voltage, the absolute value of the charge current will be smaller, and the absolute value of the ripple will be reduced correspondingly, so that the ripple is still tolerable for the battery.

In a modified embodiment, when no neutral conductor N is available, a so-called virtual star point may be formed by switching series connections of two capacitors with equal capacitance between each pair of mains conductors L1, L2 and L3 and interconnecting the midpoints of the three pairs of capacitors. The voltage between any one of the mains conductors L1 - L3 and the virtual star point may then be used for driving the primary side of a transformer that produces an auxiliary voltage for the control circuitry.

When the converter unit B1 shown in Figs. 7 and 8 is used as an onboard battery charger, the electronic components and the connections therebetween must be robust enough to withstand the mechanical strains, especially vibrations, that may occur in the vehicle. For this reason, as is shown in Fig. 9, the electronic components 88 of the converter module on the circuit board 54 may be encapsulated in a casing 90 and may be embedded in a potting material 92. As an alternative, mechanical supports may be provided in the casing 90 for stabilizing the components 88.

In the course of a charge process for the battery 44, the charge current demanded from the converter unit B1 will be set by the battery controller 48 depending on the actual state of the battery. The required charge current, represented by the demand signal  $I_t$ , may vary in a relatively wide range. In Fig. 10, the total charge current  $I_{out}$  and the shares contributed by the individual converter modules M1, M2 and M3 have been shown as a function of the demand signal  $I_t$ . When the demand signal  $I_t$  has its maximum value  $I_{max}$ , the broad controller 50 will operate all three converter modules M1 - M3 at full power, i.e. the switching frequency will be as low as the resonance frequency, so that switching losses are as small as possible.

When the current demand decreases, the switching frequency for module M3 will be increased, so that the output current of this module drops. The share of the total charge current that is provided by module M3 has been indicated in Fig. 10 by a hatched area 94. Meanwhile, modules M1 and M2 still operate at full power as is symbolised by hatched areas 96 and 98.

When the demand signal decreases further and the switching frequency of the module M3 would become too high, this module is switched to the pulse skip mode illustrated in Fig. 5. This is symbolized by an area 100 in Fig. 10. The switching frequency is set

back to the resonance frequency and is then gradually increased again so as to respond to a further decreasing demand for current. Optionally, there may be a plurality of pulse skip modes, wherein the ratio of skipped pulses to active pulses increases step-wise so as to further reduce the output current of the module.

- 5 When the limit of the skip mode has been reached, the board controller 50 switches the module M3 to the burst mode shown in Fig. 6 and symbolized by an area 102 in Fig. 10. Again, the switching frequency is set back to the resonance frequency and then gradually increased again so as to further decrease the discharge current.

10 When, with further decreasing demand  $I_t$ , the switching frequency has reached its maximum, the switching frequency of the module M2 is increased and the current share of the second module M2 is reduced (slope 104 in Fig. 4).

When the current demand has become so low that it can be fulfilled by the two modules M1 and M2 alone, the module M3 is disabled. Both modules will the operate at full power and with highest efficiency.

- 15 As the demand signal  $I_t$  decreases further, the procedure described above is repeated for the module M2 and finally for the module M1. When the minimum  $I_{\min}$  of the demand signal  $I_t$  is reached, the module M1, the only module that is still operating, is in the burst mode, and the switching frequency has been raised to the maximum.

20 In this way, the converter unit B1 operates with the highest possible efficiency for any given current demand.

As another embodiment example, Fig. 11 shows a battery charger 106 that is configured as a stationary fast charger and is connectable to the vehicle battery 44 and its controller 48 via power and control plug connectors 108a, 108b.

25 The battery charger 106 is formed by five converter units B1, B2, B3, B4 and B5 each of which may be configured as in Figs. 7 to 9. The only major difference is that the coolant water system for the base plates 56 is provided in a rack (not shown) that accommodates the circuit boards 54 of all five units. Further, since the electronic compo-

nents 88 will not be subject to substantial vibrations, they need not be embedded in potting material.

It will be understood that the fast charger will operate with 400 V three-phase mains voltage supplied to each converter unit on the respective conductors L1, L2 and L3. The mode selectors 76 (Fig. 8) will automatically detect the presence of these voltages, so  
5 that the input circuits of all units will automatically adapt to the three-phase mode.

The positive output terminal of each converter unit is connected to the plus terminal of the battery 44 via a diode 110 and a common positive pole of the power plug connector 108a, whereas the negative output terminals of the converter units B1 - B5 are con-  
10 nected to the minus terminal of the battery 44 via a minus pole of the power plug connector 108a. Again, the diodes 110 have the purpose to prevent destructive reverse currents. It will be recalled that each converter module of each of the converter units B1 - B5 has also its own output diode 46 (Fig. 7), so that redundant diodes 46, 110 are provided for increased safety. Of course, one or more reverse current detectors may also be pro-  
15 vided for the battery charger 106.

The battery controller 48 on board of the vehicle is connected to a rack controller 112 via the control plug connector 108b. The rack controller 112 controls each of the converter units B1 - B5. The battery controller 48 sends a demand signal  $I_{set}$  to the rack controller 112 which provides the demand signals  $I_t$  to each of the converter units. The  
20 rack controller 112 determines the shares of the total charge current to be provided by each of the converter units according to a scheme that is similar to the operation scheme of the board controllers 50 (Fig. 10) and has been illustrated in Fig. 12. When the demand signal  $I_{set}$  asks for a maximum charge current, all three converter units B1 - B5 will be operating at full power, and when the current demand decreases, the units will  
25 successively be dimmed and switched off. Since the output current delivered by each individual unit cannot be decreased below a certain limit, there are transition states in which two units operate at reduced power simultaneously, similarly as in Fig. 10. For example, when the output current of the unit B5 cannot be decreased further, the output current of the next unit B4 will be decreased instead. As soon as the demand has be-

come so low that it can be fulfilled with the units B1 - B4 alone, the unit B5 is switched off and the unit B4 will operate again at full power.

As is shown in Fig. 11, the power plug connector 108a is supervised by a monitoring circuit 114. It will be understood that the power plug connector 108a must be capable of transmitting charge currents which may become as large as 100 A or more. As a consequence, poor contact at the plug connector 108a could result in dangerous overheating. The monitoring circuit 114 is provided for detecting the occurrence of poor contact at the plug connector. For example, the monitoring circuit 114 may be arranged to measure a voltage drop across the plug connector. As another alternative, the monitoring circuit may detect the temperature in the plug or it may detect RF signals that are induced by chatter or sparks produced in a connector. Whenever the monitoring circuit 114 detects a bad contact condition, the rack controller 112 will disable the charger.

Moreover the rack controller 112 has a self-monitoring function monitoring the operation of all five converter units B1 - B5. In case that one of these units should fail, the rack controller 112 would not only switch off this unit but would also send an error signal E to the battery controller 48, informing the battery controller that the charger 106 can only operate at a reduced power.

The battery controller 48 watches the charge current and would abort the charge process when it finds that the actual charge current does not correspond to the demand signal  $I_{set}$ . Thus, when the demand for charge current cannot be met because one or more of the converter units fail, the battery charge process would be aborted. However, the error signal E is capable of switching the battery charger 48 to a reduced power mode in which  $I_{set}$  is small enough to be met by remaining units of the charger. For example, when each of the converter units B1 - B5 has a maximum power of 10 kW, and one of the units fails, the error signal E would cause the battery controller 48 to switch from a 50 kW mode to a 40 kW mode, so that the charge process could be continued, though with reduced power.

The same concept is also applicable in case of failure of one of the converter modules M1 - M3 in one of the units B1 - B5 or in the onboard battery charger.

Fig. 13 shows an embodiment of a fast charger with three converter units B1 - B3. The unit B1 is composed of three modules M11, M12, and M13. The unit B2 is composed of three modules M21, M22, and M23. The unit B3 is composed of three modules M31, M32, and M33.

- 5 When the demand for current is at maximum, all nine modules are operating at full power. When the demand decreases, the modules are reduced in power output and eventually switched off in the sequence that has been illustrated in Fig. 14. This scheme assures that the power is always distributed approximately evenly over the three units B1, B2 and B3, which results in an efficient utilization of the module cooling capacity in the
- 10 reduced power modes.

In Fig. 13, the modules M13 (connected between L1 and L3), M21 (connected between L2 and L1), and M32 (connected between L3 and L2) have been shown in faint lines, which symbolizes that these modules are the first to be switched off. It will be noted that, when these three modules have been switched off, the load will be balanced be-

15 tween the three pairs of conductors L1 - L3.

The next modules to be disabled will be M12, M23, and M31. When these three modules have also been switched off, the load will again be balanced. In this way, the scheme for disabling individual modules in different ones of the units B1 - B3 may be used for controlling the load balance on the mains conductors.

CLAIMS

1. A battery charger for electric vehicles, **characterised** in that the battery charger (B1; 106) is composed of at least three identical current controlled AC-DC converter  
5 modules (M1, M2, M3) having reverse current protected outputs connected in parallel to a charge terminal of the battery (44).
2. The battery charger according to claim 1, comprising at least one converter unit (B1 - B5) composed of three converter modules (M1, M2, M3) and having a power supply  
10 circuit (70 - 86) switchable between a three-phase supply mode and a single-phase supply mode.
3. The battery charger according to claim 2, wherein the supply circuit comprises a mode selector (76) adapted to detect the presence of voltages on mains conductors (L1, L2, L3) and to automatically select the supply mode in response to the detected vol-  
tages.
- 15 4. The battery charger according to claim 2 or 3, wherein the power supply circuit comprises three first bridge circuits (70 - 74) by which, in the three-phase supply mode, the input sides of the converter modules (M1, M2, M3) are connected phase-against-  
phase in a triangular configuration, and three second bridge circuits (80-86) by which, in the single phase mode, the input sides of the converter modules (M1, M2, M3) are  
20 connected phase-against-ground in a star configuration.
5. The battery charger according to any of the preceding claims, wherein the con-  
verter modules (M1, M2, M3) are configured as resonant converters.
6. The battery charger according to claim 5, comprising a controller (50; 112) ad-  
apted to individually control the output currents ( $I_{out}$ ) of the converter modules (M1-  
25 M3) in accordance with a variable demand signal ( $I_t$ ;  $I_{set}$ ) such that the current demand is met with the smallest possible number of active converter modules, with as many  
converter modules as possible operating at full power.

7. The battery charger according to claim 6, wherein each converter module (M1-M3) has at least two different modes of operation which cover different ranges of output currents, and the controller (50; 112) is adapted to control the power modules, in response to a change of the demand signal ( $I_t$ ;  $I_{set}$ ), such that a step-wise change of the output current caused by switching the mode of operation is compensated by changing the switching frequency ( $f$ ) of the resonant converter, so that the output current becomes a continuous function of the demand signal.
8. The battery charger according to any of the preceding claims, configured as an onboard battery charger, comprising a circuit board (54) on which electronic components (88) are mounted and which is supported on a liquid cooled base plate (56) connecting to a coolant system (58, 62) of the vehicle, wherein a controller (50) of the battery charger is adapted to control the liquid coolant system.
9. The battery charger according to any of the claims 1 to 7, configured as a stationary charger connectable to the vehicle battery (44) via a power plug connector (108a).
10. The battery charger according to claim 9, comprising a plurality of converter units (B1 - B5) having each the features specified in any of the claims 2 to 4 and having their outputs connected in parallel to the power plug connector (108a).
11. The battery charger according to claim 9 or 10, comprising a plurality of converter units (B1 - B5) each of which is composed of three converter modules (M1, M2, M3) connectable phase-against-phase in a triangular configuration, and a control system having a mode of operation in which at least two converter units operate at reduced power simultaneously, with at least one converter module in each of these units being disabled.
12. The battery charger according to any of the claims 9 to 11, comprising a monitoring circuit (114) adapted to detect a contact condition of the power plug connector (108a), and a controller (112) adapted to abort the battery charge process when the monitoring circuit (114) detects a bad contact condition of the plug connector.

13. The battery charger according to any of the preceding claims, comprising a controller (112) connectable to a battery controller (48) for the vehicle battery (14) and adapted to transmit an error signal (E) to the battery controller (48) for switching the battery controller to a reduced power charge mode when at least one of the converter modules (M1 - M3) should fail.

5

14. A battery charging system for electric vehicles, comprising an onboard battery charger as specified in claim 8 and a stationary battery charger (106) as specified in any of the claims 9 to 13, wherein the onboard battery charger has the same design as a single module (M1 - M3) or a single unit (B1 - B5) of the stationary battery charger (106).

10

Fig. 1

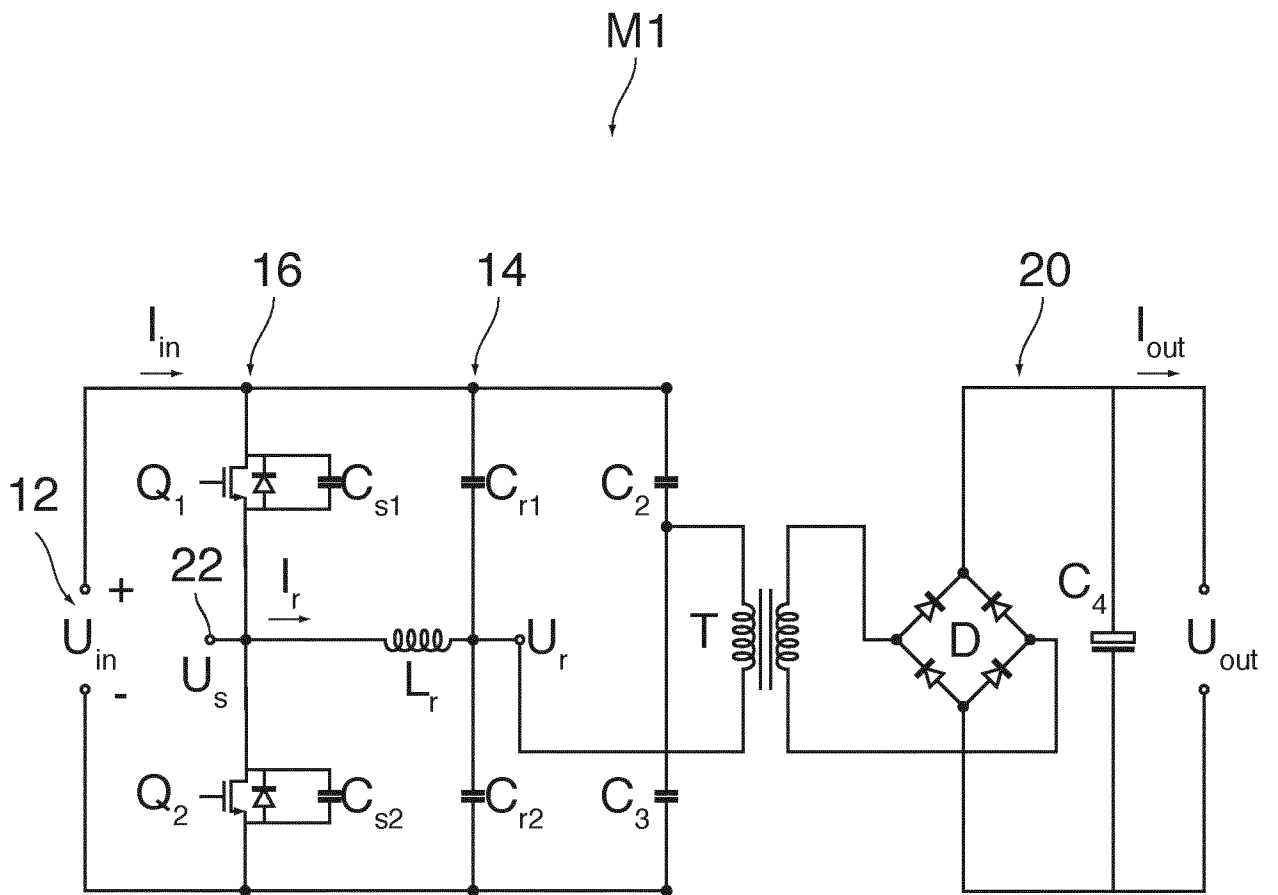

Fig. 2

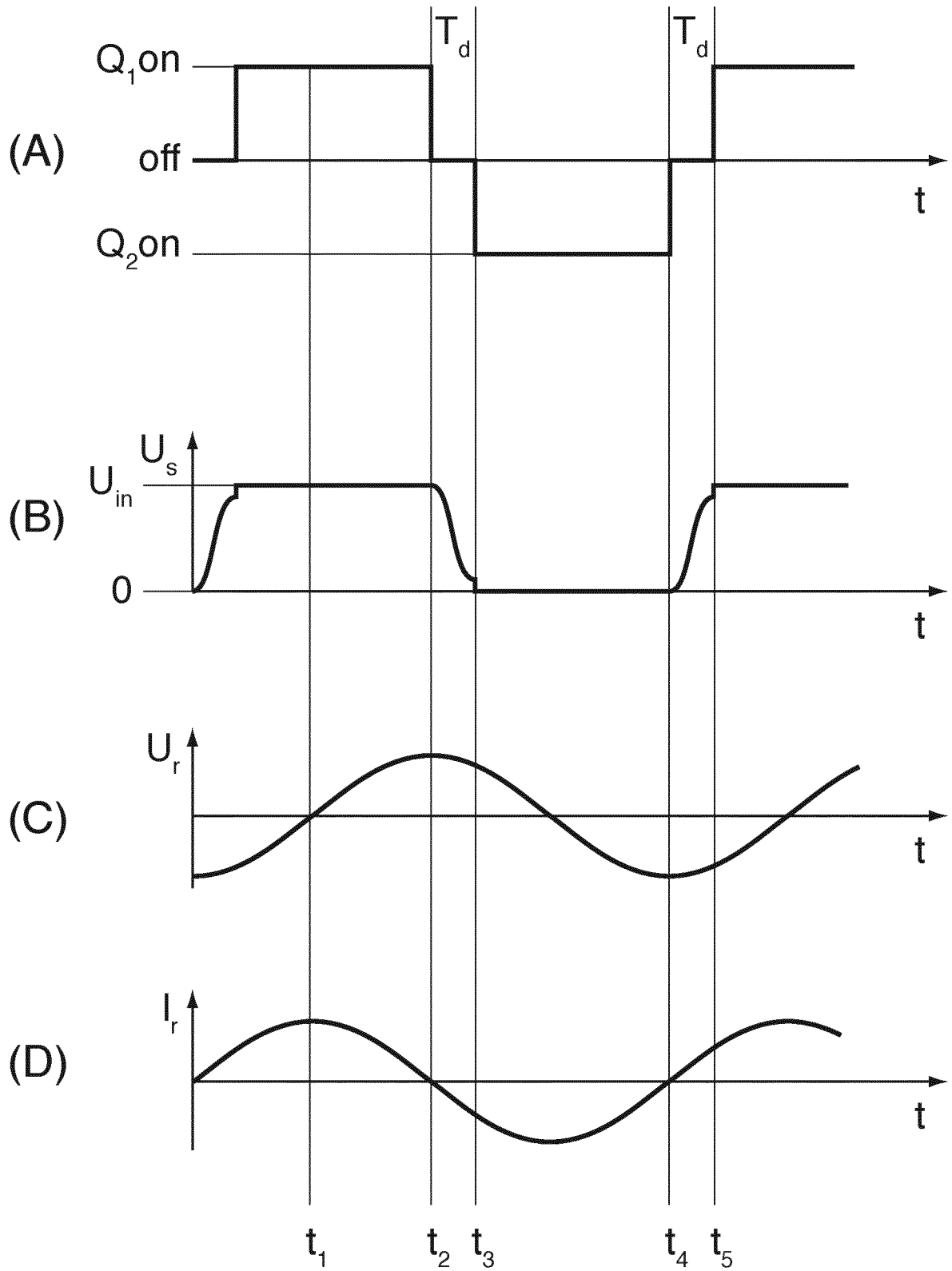

Fig. 3

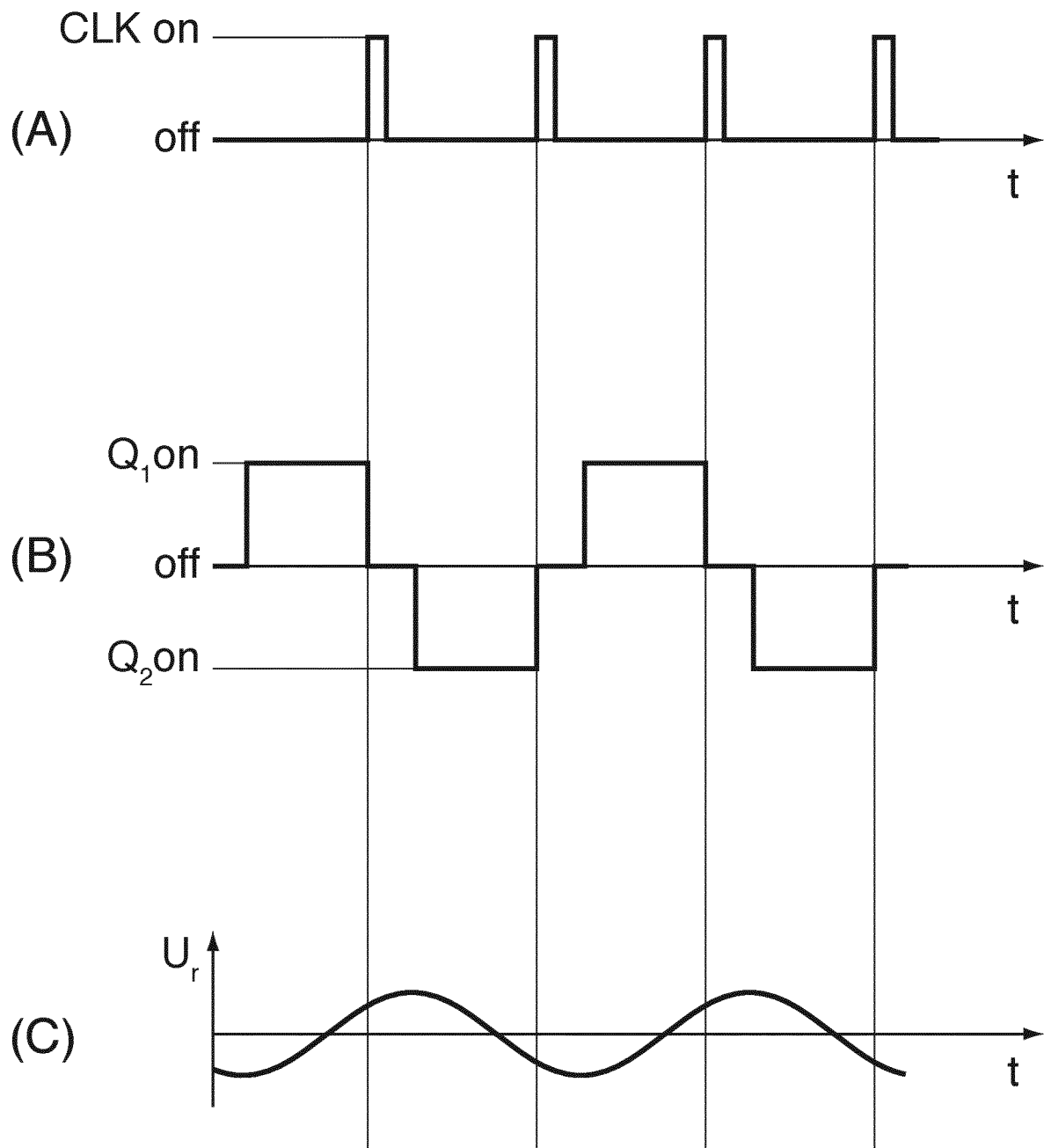

Fig. 4

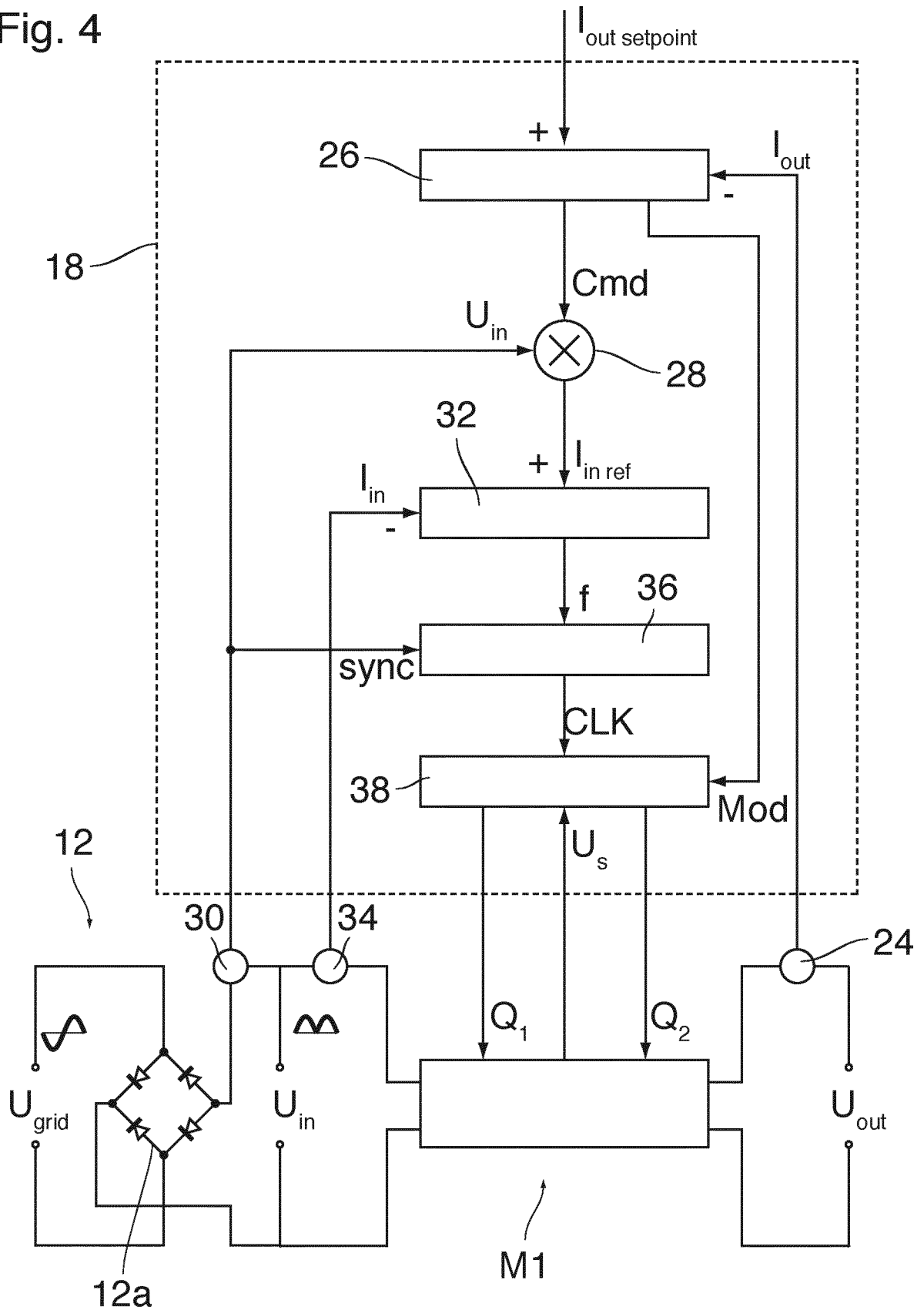

Fig. 5

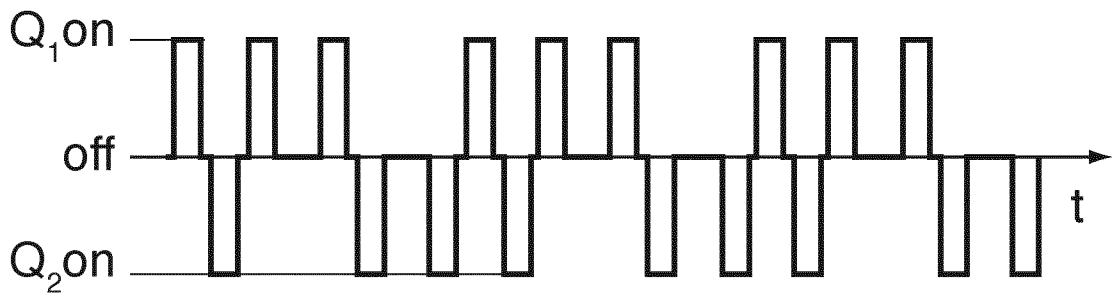

Fig. 6

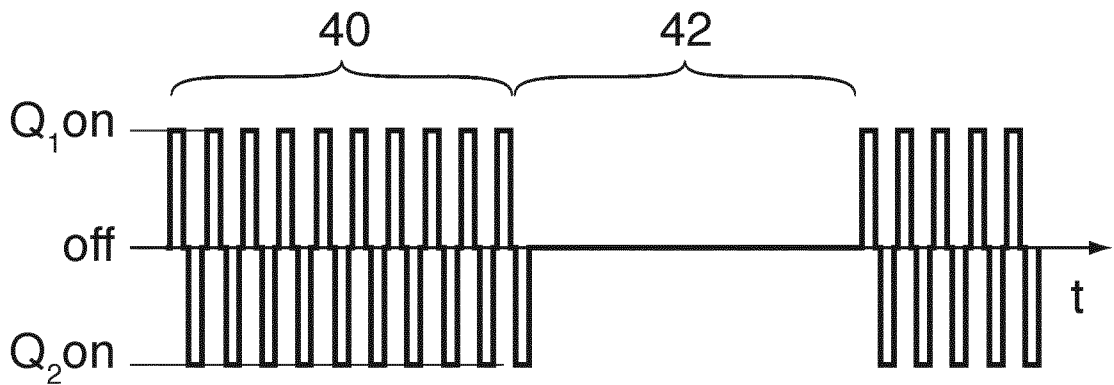

Fig. 7

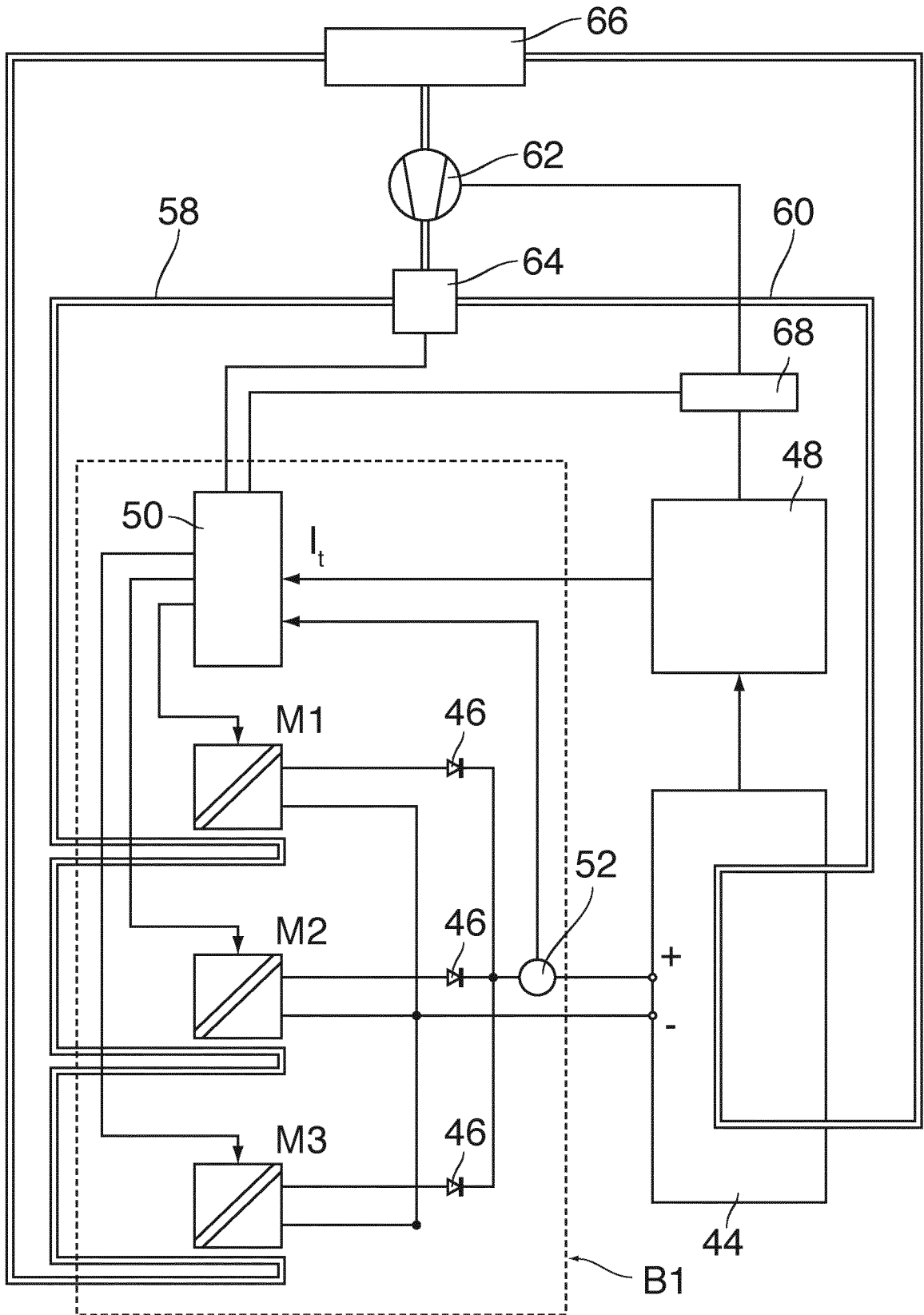

Fig. 8

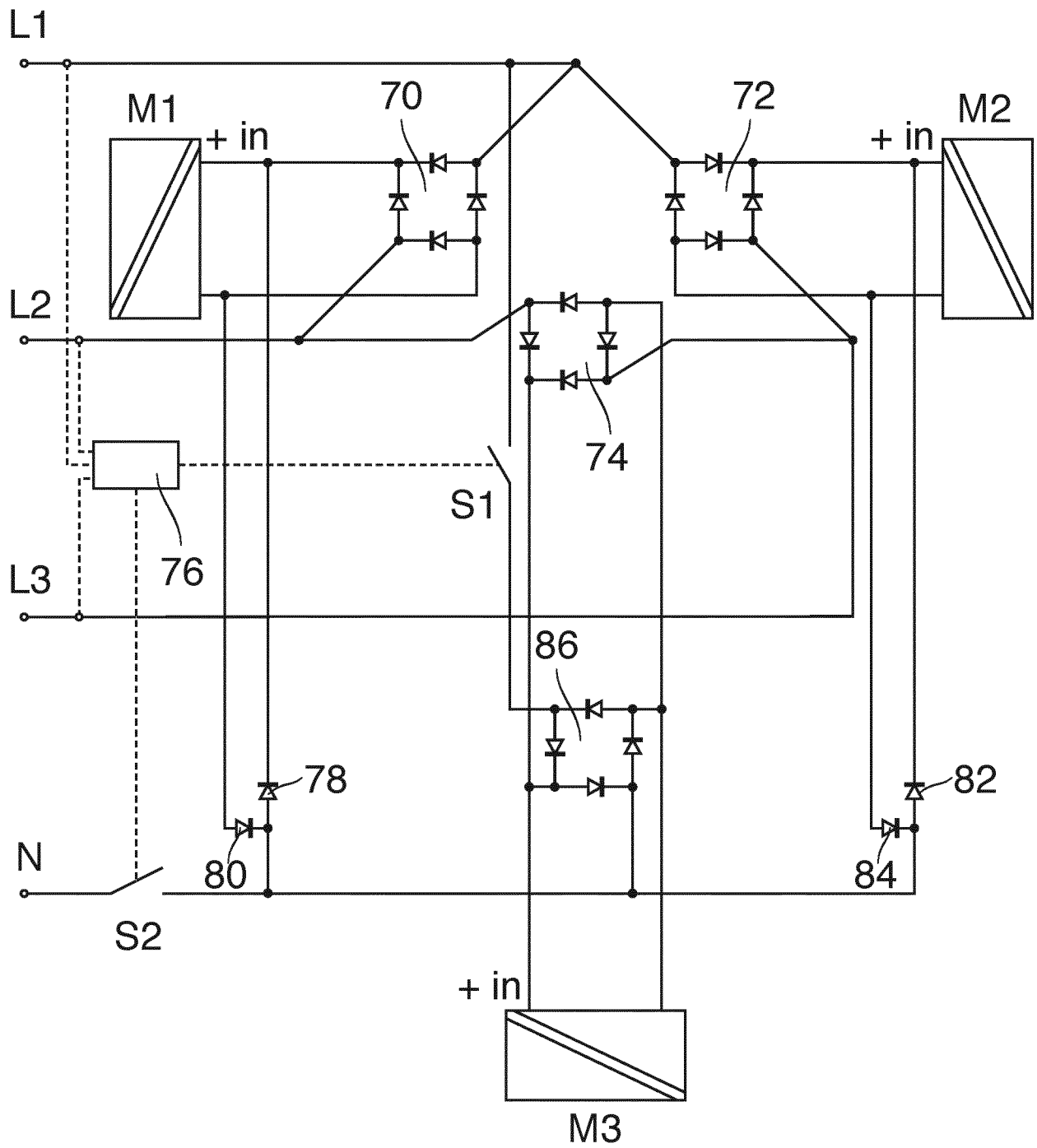

Fig. 9

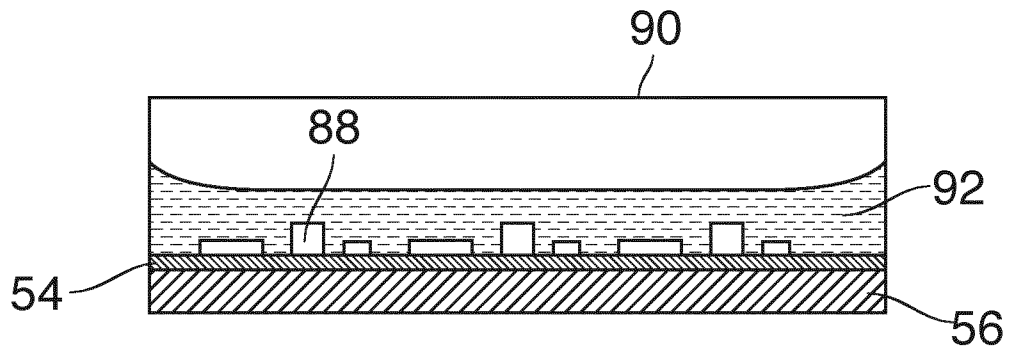

Fig. 10

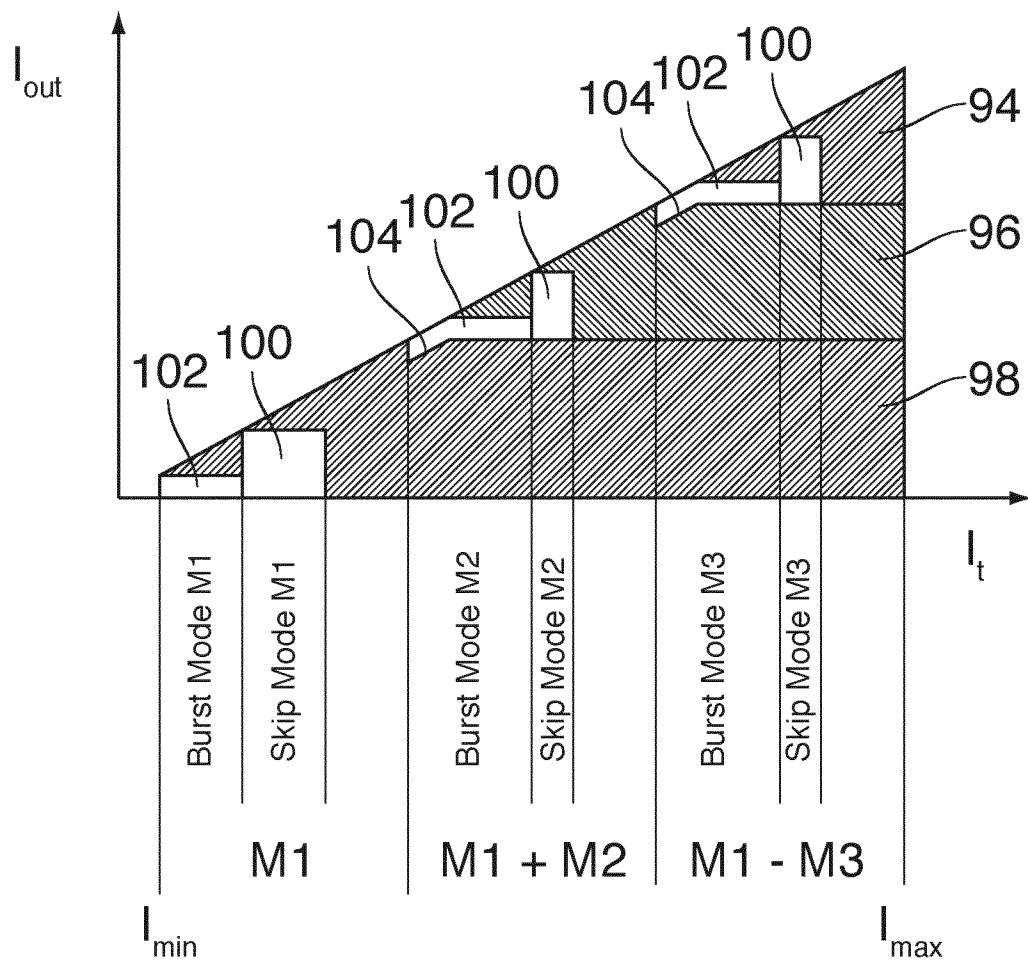

Fig. 11

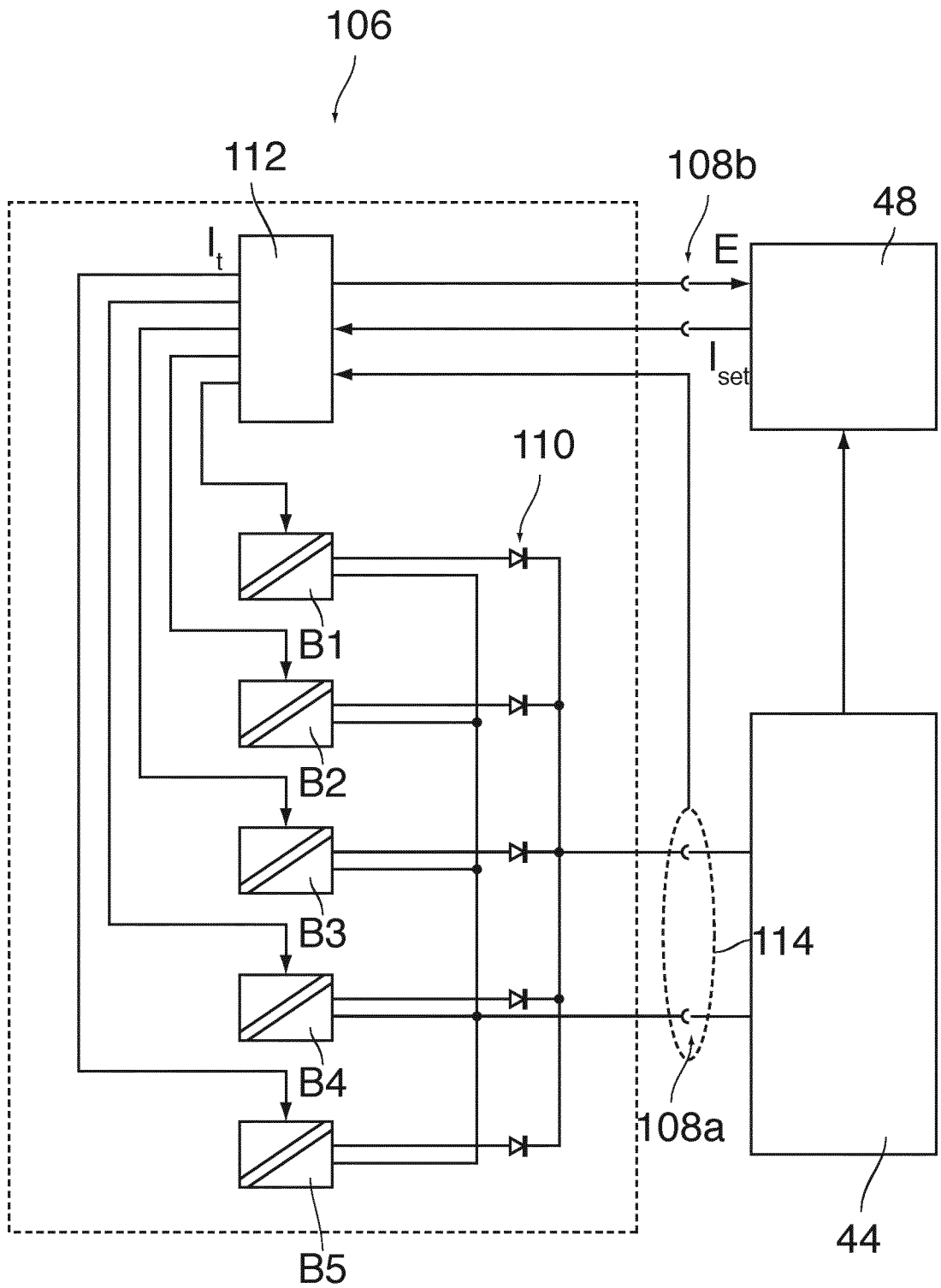

Fig. 12

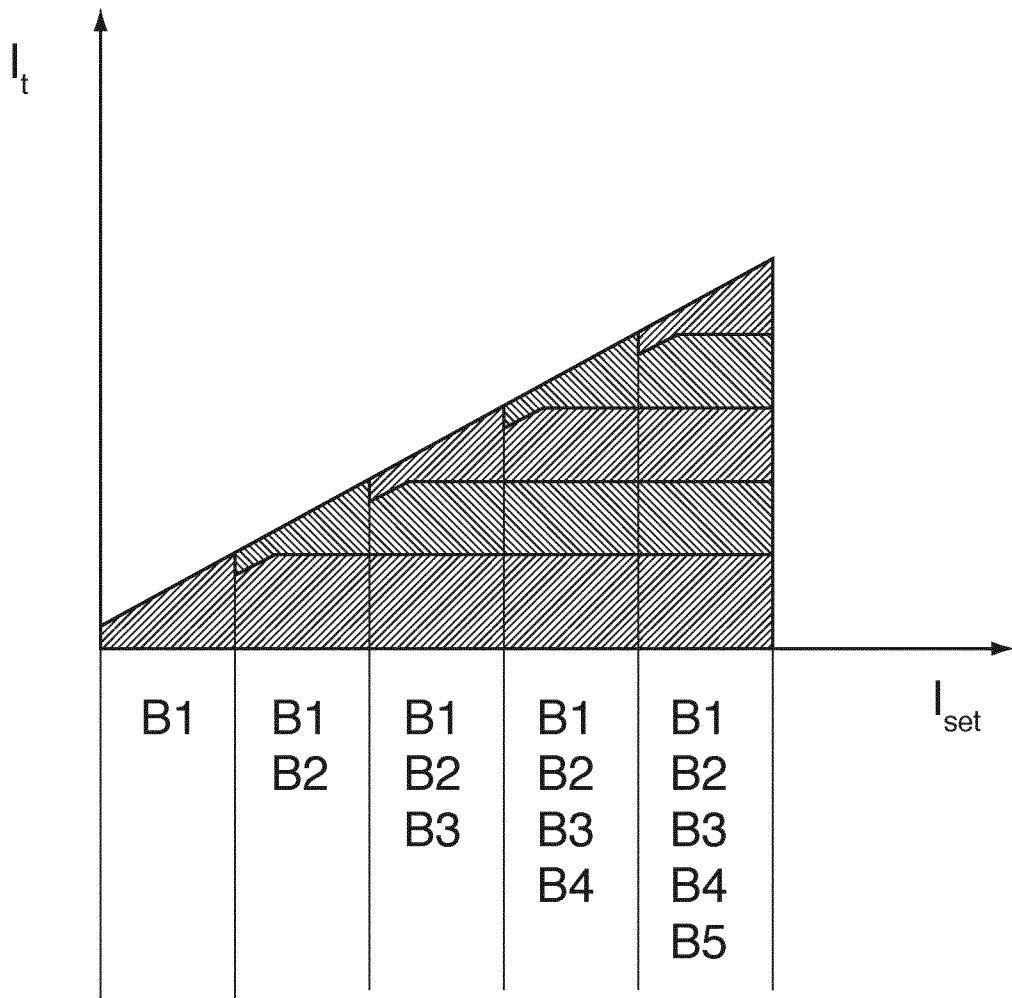

Fig. 13

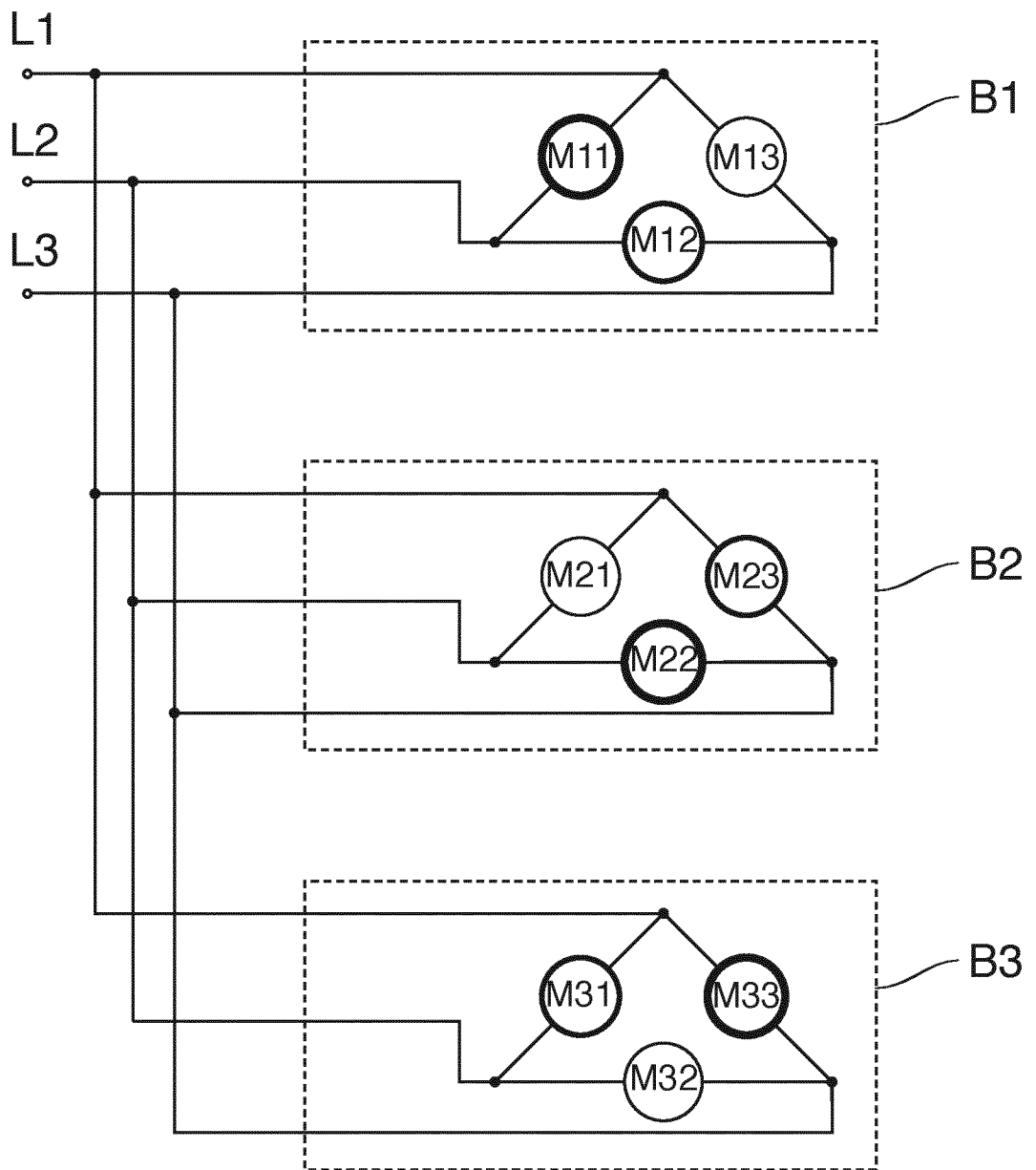

Fig. 14

