

[54] APPARATUS FOR TREATING FABRICS WITH STEAM

3,011,327 12/1961 Brownell..... 68/5 C

[75] Inventors: Tadashi Miyamoto; Masaaki Iwahashi, both of Wakayama, Japan

FOREIGN PATENTS OR APPLICATIONS

22,060 10/1892 Great Britain..... 68/157

[73] Assignee: Wakayama Iron Works Ltd., Wakayama-shi, Japan

Primary Examiner—Billy J. Wilhite  
Assistant Examiner—Philip R. Coe  
Attorney, Agent, or Firm—Hall & Houghton

[22] Filed: Nov. 7, 1973

[21] Appl. No.: 413,526

[57] ABSTRACT

[30] Foreign Application Priority Data

July 26, 1973 Germany..... 2337874

[52] U.S. Cl..... 68/5 C, 34/239, 242/77.1

[51] Int. Cl..... D06c 1/00

[58] Field of Search ..... 68/5 C, 7, 8, 157, 199; 242/77.1; 34/239, 240, 153, 104, 105

Apparatus is provided for use in treating dyed fabric with steam to fix the dye thereon which includes a horizontally positioned steam autoclave, winding reel means movably positioned into and out of the autoclave, the winding reel means including a support shaft and a plurality of groove support arms extending radially outwardly from each end of the support shaft into which bar means are horizontally mounted and span the distance between pairs of complementary support arms of the reel and around which the fabric to be treated is wrapped. Bar support cams are mounted on the support shaft in coaxial relationship and includes means to shift the cams. The invention also includes the method of dyeing such fabric.

[56] References Cited

UNITED STATES PATENTS

1,006,784	10/1911	Payet.....	242/77.1 X
1,799,713	4/1931	Walker.....	242/77.1 X
1,862,615	6/1932	Walker.....	242/77.1
2,371,073	3/1945	Smith.....	242/77.1 X

5 Claims, 8 Drawing Figures

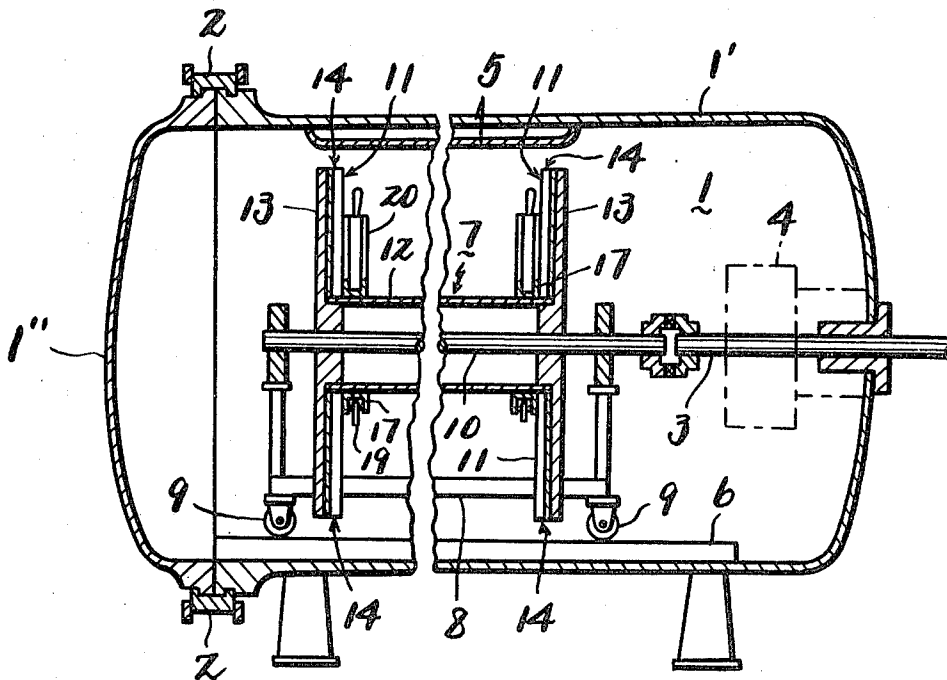

Fig 1

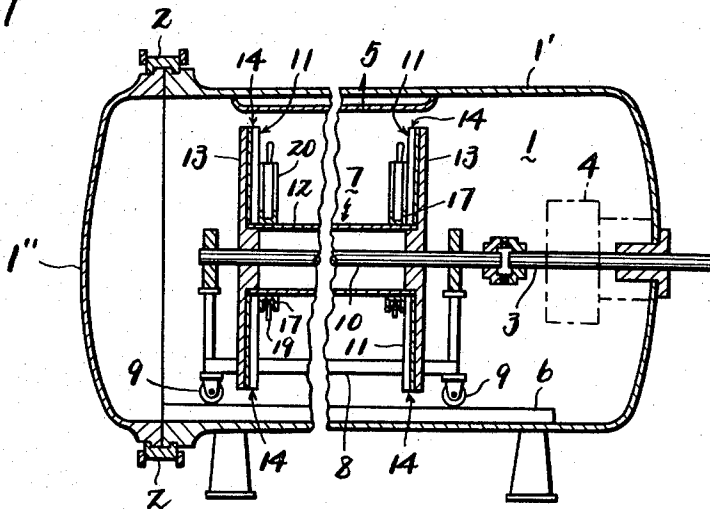

Fig 2

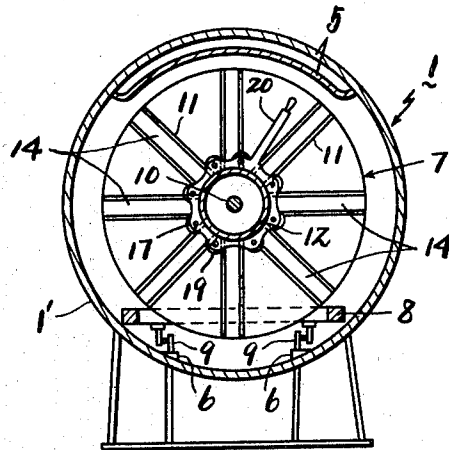

Fig 5

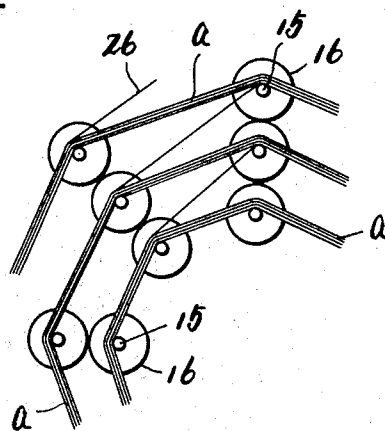

Fig 4

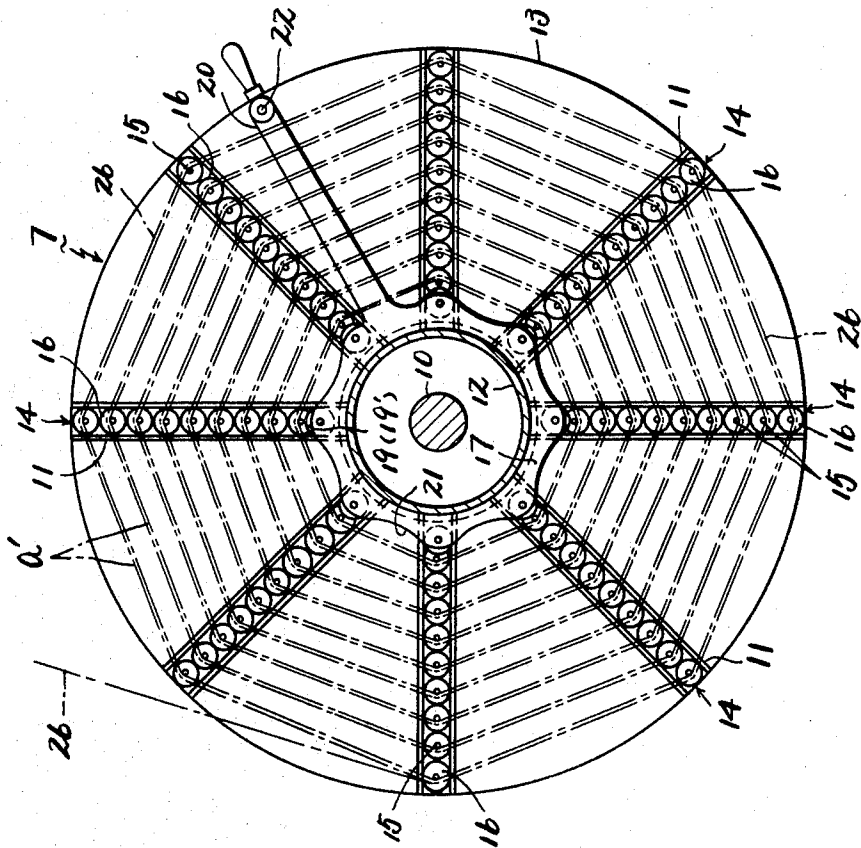

Fig 3

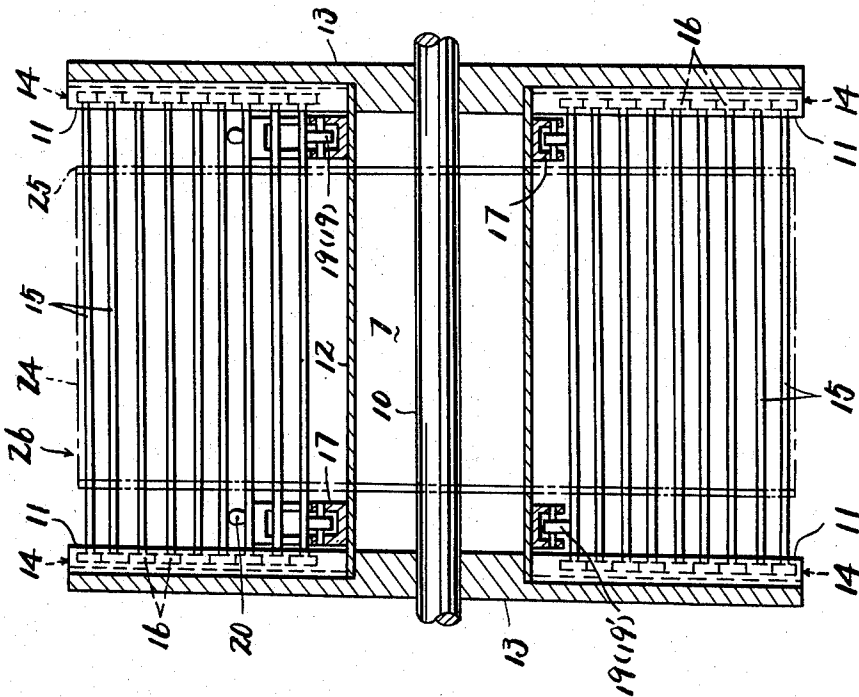

Fig 6

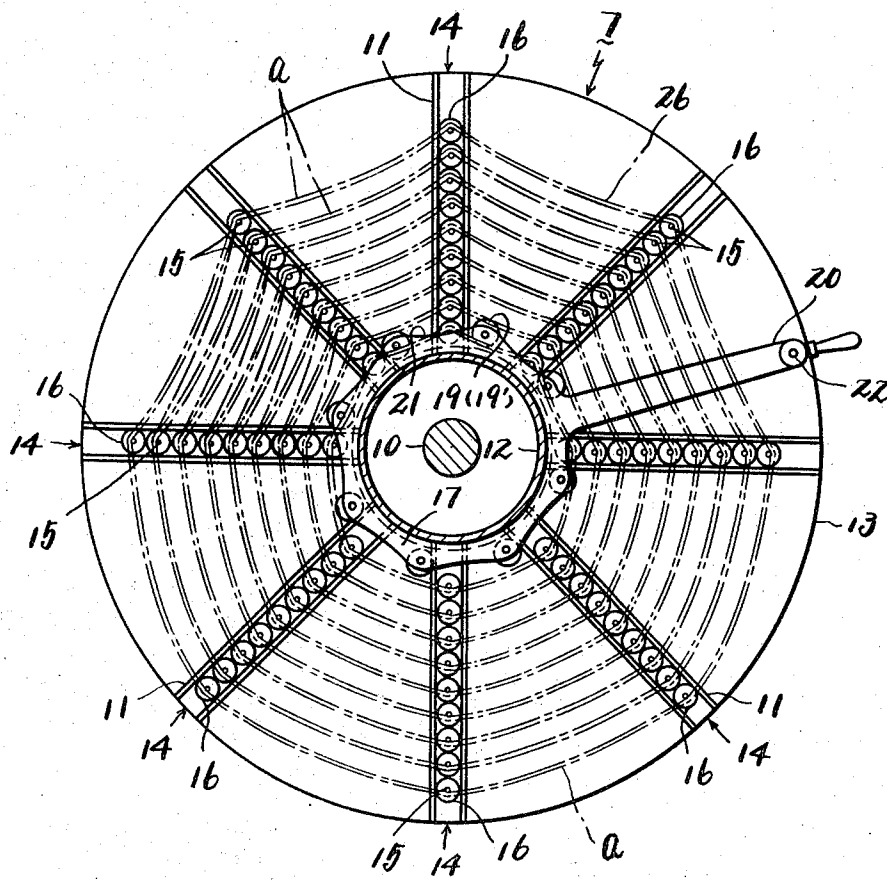

Fig 7

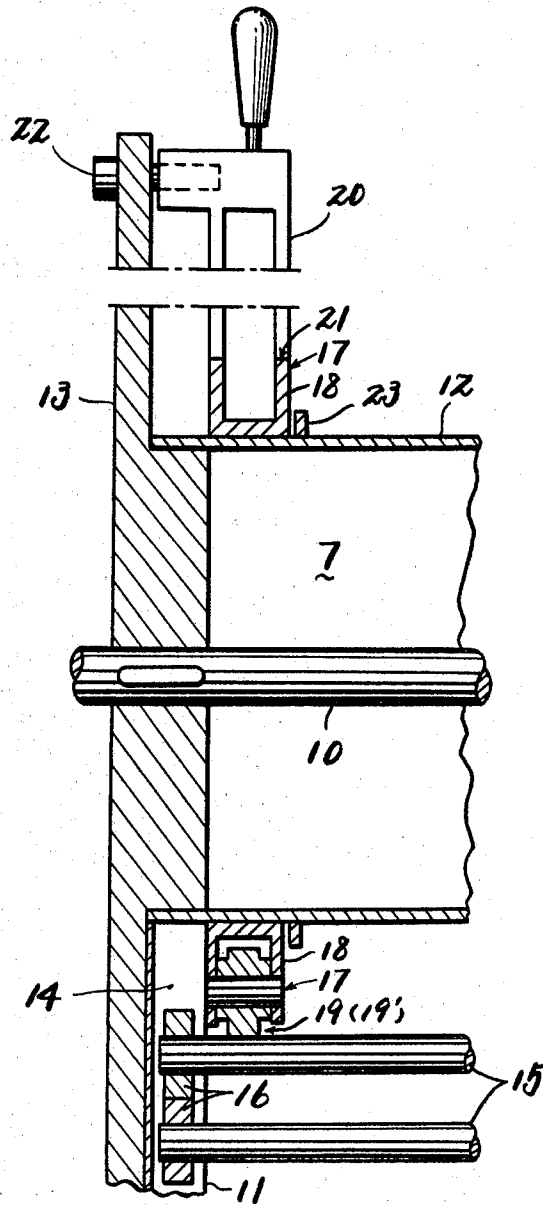
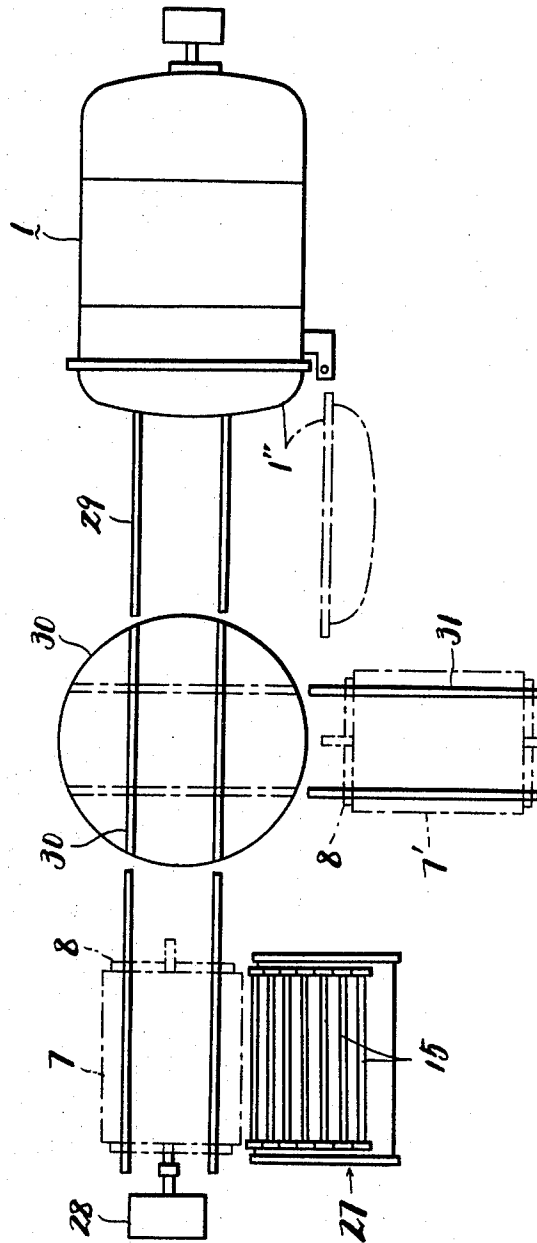

Fig 8



## APPARATUS FOR TREATING FABRICS WITH STEAM

### DETAILED DESCRIPTION OF THE INVENTION.

The present invention relates to apparatus for treating fabrics with hot steam after such fabrics have been subjected to a dyeing operation for the purpose of fixing the dye in the dyed fabrics and to aid in the color-development thereof. Heretofore, a fabric after it has been dyed is subjected to steaming either single or with an undercloth placed thereunder to effect the fixation of the dye in the dyed fabric and to aid in the color-development thereof. In this connection, the application of steaming to the fabric uniformly over the entire surface of the fabric is of the utmost importance in order to prevent unevenness of color-development and other drawbacks. Furthermore, there has been a need for apparatus of this type which makes it possible to achieve an increased amount of treatment per apparatus unit and which can also permit treatment of fabrics of a wider width.

The conventional vertical steamer wherein a fabric to be treated with an undercloth placed thereunder is widthwise suspended in a vertical steam oven or autoclave possesses several drawbacks. For example, the conventional vertical steamer of this type comprises an upright support rod disposed centrally of the steam oven and has on the top thereof radially extending suspension arms provided with suspension attachments, wherein one side of the undercloth are successively locked by said suspension attachments so that the geminated fabric is suspended from the suspension arms while being maintained in a circinate form. In such case, the fabric to be treated is contacted with the undercloth on opposite sides and thereby frictionally held and suspended in a free state. Such circinate geminated fabric with the fabric to be treated held by the undercloth is then subjected to seaming by hot steam, i.e., superheated steam which penetrates the same. The steam is blown from the lower region of the steam oven autoclave, passing upwardly between the circinate layers of the fabric, then having its direction of travel reversed by reversing means, such movement of the steam being repeated with the steam circulating, during which it penetrates the fabric to carry out the steaming treatment. In the vertical steamer, since the fabric to be treated is held by the undercloth and maintained in suspended condition by the friction created therebetween as described above, it tends to sag or slip down under its own weight if the fabric to be treated is too heavy. Such tendency imposes restrictions on the amount of treatment per oven and on the fabric width in the case of treatment of wider fabrics, thus failing to meet the recent requirements oriented toward treatment of wider fabrics. Further, in order to prevent formation of water drops which would spoil the fabric to be treated, the temperature of the upper region of the oven or autoclave where such water drops are likely to form is raised by blowing hot steam into said region. But in such cases, the temperature distribution in the oven becomes ununiform, and moreover, since the fabric is stationary in the suspended condition, steaming cannot be applied uniformly. Further, the mounting and dismounting of the undercloth placed under the fabric is very troublesome.

In the conventional steaming process using the so-called horizontal steamer is opposed to said vertical

steamer, the fabric to be treated is wound on a take-up reel either singly or with the undercloth placed thereunder and the resulting geminated fabric is installed in the oven or autoclave where it is then subjected to steaming. Therefore, there are advantages that the amount of treatment per oven is greater than in the case of the vertical steamer and that wider fabrics can be treated. On the other hand, since the fabric is wound directly on the take-up reel in layers, it is difficult for the steam to penetrate deep into the layers of fabric. Thus, since the steaming cannot be applied uniformly over the entire fabric, there is the disadvantage of detracting from the quality of the fabric.

The present invention is intended to produce a treated fabric having none of the aforementioned defects and provides a method and an apparatus the aforementioned method, which constitutes improvements in the horizontal steamer type, wherein a fabric to be treated is wound in several separate stratum and hot steam is blown into the steam oven at suitable intervals of time in such a manner as to alternately create higher and lower pressure conditions in the oven with the fabric maintained in a relaxed condition to allow the steam to uniformly penetrate the fabric to assure stable fixation of the dye, thereby making it possible to treat fabrics, particularly wider fabrics in large amounts without involving unevenness of color-development.

One form of the present invention is a method invention wherein in winding a fabric to be treated on a take-up reel either singly or with an undercloth placed under said fabric, the winding is divided into several separate stratum of suitable thickness and, during steaming operation, with the winding tension relieved the take-up reel is slowly rotated alternately in forward and reverse directions.

A second form of the present invention is a method wherein, in addition to said first method invention, hot steam, i.e., superheated steam, is blown into the steam oven autoclave at predetermined intervals of time in such a manner as to alternately create higher and lower pressure conditions in the steam oven. The other two forms of the present invention are apparatus inventions used for embodying said method inventions. One of said apparatus inventions comprises a horizontally installed steam oven having a removable closure plate on one side and on the other side steam blowing means disposed in the interior and a working shaft driven from the outside, a support table capable of being easily taken in and out of the steam oven, and a take-up reel composed of grooved support arms mounted on both ends of a rotary shaft journaled on said support table in such a manner that said support arms extend radially with their open sides opposed to each other, a number of bars horizontally mounted with their opposite ends fitted in said grooved support arms, and bar support cams each having alternate ridges and recesses formed around the periphery thereof to support opposite ends of said bars, said bar support cams being mounted rotatably on and coaxially with said rotary shaft, said take-up reel being slowly rotated alternately in forward and reverse directions during steaming. The other apparatus invention comprises, in addition to said first, apparatus, steam blowing means for blowing saturated steam into the steam oven during steaming at predetermined intervals of time in such a manner as to alternately create higher and lower pressure conditions in the steam oven.

3

The present invention will now be described in more detail with reference to the drawings showing an embodiment of the invention.

FIG. 1 is a front view, in longitudinal section, of a steam oven or autoclave made in accordance with the present inventive apparatus, said steam oven being shown in operation;

FIG. 2 is a side view, in longitudinal section, of the steam oven shown in FIG. 1;

FIG. 3 is a front view of a take-up reel shown when the fabric winding operation is being carried out;

FIG. 4 is a side view of the take-up reel shown in FIG. 3;

FIG. 5 is an enlarged view of some of the separate stratum;

FIG. 6 is a side view of the take-up reel shown when steaming operation is being carried out;

FIG. 7 is an enlarged sectional view showing the bar support part of the take-up reel; and

FIG. 8 is an explanatory view showing how to use the present inventive apparatus.

Designated at 1 is a steam oven or autoclave which is horizontally positioned. The steam oven is composed of an oven body 1' and a closure plate 1''. The closure plate 1'' is fixed in position by attachments such as clutches 2. A working shaft 3 adapted to be driven by suitable drive means extends into the oven body 1'. Further, steam blowing means 4 are provided inside the oven 1 for blowing steam, such as, for example, superheated steam, into the oven. Part of the upper inner wall of the steam oven 1 is composed of a double wall plate 5 so that hot steam is blown into the space defined by said double wall plate to heat the upper inner wall. Installed inside the oven 1 on the bottom thereof are rails 6 which are connectible to mating outside rails to be brought thereto from the side of the closure plate 1''. Designated at 7 is a take-up reel rotatably mounted on the support table 8. During steaming, the shaft 10 of the take-up reel 7 on which a fabric to be treated is wound is coaxially connected to the working shaft 3 and rotated by rotating the working shaft 3. The support table 8 is carried by wheels 9 for movement along the rails 6.

As shown in FIGS. 3 through 7, the take-up reel comprises a plurality of grooved support arms 11 of U-shaped cross-section with one side open arranged on circular lateral plates 13, 13 on opposite sides on a cylindrical shaft 12 in such a manner that they extend radially in opposed equispaced relation, said cylindrical shaft 12 being fitted in position to be coaxial with the rotary shaft 10. Each bar 15 has rollers 16, 16 on opposite ends thereof made of an elastic material such as rubber and loosely fitted in the guide grooves 14 in the opposed grooved support arms 11, whereby said bars 15 are horizontally mounted in said arms 11. Thus, such bars 15, when horizontally mounted, are superposed one upon another.

Rotatable bar support cams 17 are mounted on the cylindrical shaft 10 of the take-up reel 7 on opposite sides inwardly of the grooved support arms 11. Thus, as shown, such bar support cam 17 comprises a grooved annulus 18 having a peripheral groove in which the same number of cam rollers 19' as the number of grooved support arms 11 are rotatably fitted with part of each cam roller projecting outside the peripheral groove. Therefore, the circumferential surface of such bar support cam 17 has a plurality of ridges 19 de-

4

signed by said cam rollers 19'. Such cam rollers may not necessarily be employed and instead other element having a raised curve similar thereto may be used.

Designated at 20 is a lever for rotating the associated bar support cam, said lever being manually moved to rotate the cam 17 so that the bars 15 may be supported by the ridges 19 or by recesses 21 each defined between adjacent ridges. Pins 22 are associated with the levers 20 to lock them, e.g., to the circular lateral plates 13 in order to selectively fix the bar support cams 17 in connection with either the ridges 19 or the recesses 21. Designated at 23 is a stop ring serving as a guide for the rotation of the associated bar support cam 17.

A fabric 24 to be treated is wound on the take-up reel 7 either singly or with an undercloth 25 placed thereunder to form a geminated fabric 26. The following description refers to the geminated fabric 26. The winding operation is carried out outside the steam oven or autoclave 1 by automatically fitting the bars 15 loosely in the grooved support arms 11 by suitable drive means. More particularly, as shown in FIG. 8, there is provided bar supply means 27 for sending bars 15 rolling down onto the take-up reel 7 on the support table 8, and the shaft 10 of the take-up reel 7 is connected to suitable drive means 28 whereby the take-up reel is rotated and, as shown in FIGS. 3 through 5, bars 15 are successively introduced into the grooved support arms 11, one bar in each support arm, said bars thus introduced being supported on the ridges 19 of the bar support cams 17. When the first group of bars 15 have thus been horizontally mounted, the feeding of bars is interrupted and the geminated fabric 26 is wound therearound in a fixed thickness into the form of a polygon to form a first wound stratum, whereupon a second group of bars 15 are introduced and the fabric is similarly wound therearound to form a second wound stratum, such introduction of bars and winding of the fabric being continuously repeated until several separate polygonal wound stratum *a* are formed. Since the arms 15 which are successively horizontally mounted have their rollers 16 placed one upon another within the grooves 14 of the grooved support arms 11, the split wound stratum may have any desired thickness up to a value approximately equal to the diameter of the rollers 16. Thus, the geminated fabric 26, as a whole, is wound into a continuous circinate form.

The support table 8 carrying the take-up reel on which the geminated fabric 26 has thus been wound is then moved through the opened closure plate 1'' into the steam oven 1' for installation therein, and the closure plate 1'' is then tightly closed, with the shaft 10 being connected to the working shaft 3. The latter shaft is then driven, while steam is blown from the steam blowing means to carry out steaming operation.

In this case, before the take-up reel 7 is conveyed into the steam oven 1, the levers 20 are manipulated so that the bars 15 which were being supported by the ridges 19 during winding operation may be supported by the recesses 21 of the support cams 17, as shown in FIG. 6. As a result, when the take-up reel 7 is rotated, the bars 15 in the upper half of the lowermost row are displaced from the ridges 19 into the recesses 21 under their own weights. As this displacement takes place, the stacked bars 15 are moved toward the axis of the take-up reel 7 and the wound stratum of the geminated fabric 26 become wound stratum *a* with the tension relaxed, as shown in FIG. 6. In this manner, the gemi-

nated fabric 26 is treated with steam in a substantially tensionless condition. In addition, depending upon the kind of a fabric to be treated, there are cases in which steaming is carried out with a substantial tension maintained as in the wound condition with the bars supported on the ridges.

The working shaft 3, to which the shaft 10 of the take-up reel 7 is connected when placed within the steam oven 1, is adapted to be rotated through a predetermined amount alternately in forward and reverse directions so that the take-up reel 7 is slowly rotated. The rotation of the take-up reel in a single direction would result in the wound stratum of fabric being laterally shifted or being wrinkled due to the weight of the fabric and the unevenness of winding and of bar resistance, whereas said forward and reverse rotation is effective to prevent the lateral shifting and wrinkling of the wound stratum of fabric even if the tension on the wound fabric is relaxed. Further, it also serves to somewhat deviate the position of contact between the bars and the fabric whereby the occurrence of unevenness of treatment due to bar contact is prevented. The steam, such as superheated steam from the steam blowing means 4 is saturated steam. Thus, the interior of the oven or autoclave is evacuated by a suction pump to create a vacuum pressure and steam is then fed thereto to pressurize the same, these operations being repeated at predetermined intervals of time.

As a result, the steam becomes nearly 100% saturated steam, penetrating the wound stratum of the geminated fabric 26 from both the inside and the outside. If steam is fed to pressurize the interior of the oven when the latter has atmospheric pressure, the steam can hardly penetrate the wound stratum uniformly since air remains in the interior of the wound stratum.

When the interior of the oven is evacuated after treatment with hot steam, the boiling point of water is lowered, so that the moisture which has condensed in the interior of the wound stratum begins to evaporate, thus making it possible to assure that the treated fabric is in a dried condition when taken out of the oven.

When the steaming operation is completed, the closure 1' of the steam oven 1 is opened to take out the take-up reel 7 by means of the support table 8, and in the case of the geminated fabric 26 it is rewound while separating the treated fabric 24 and the undercloth 25 from each other. In addition, as shown in FIG. 8, a turntable 30 carrying rails 30' may be installed in the intermediate portion of rails 29 for the support table so that the rails 30' may be connected to rails 31 which are at right angles to the rails 29. With this arrangement, the conveying of the fabric to be treated into the oven after being wound, the positioning of a spare take-up reel 7' for the next winding operation and the removal of a take-up reel from the oven after completion of steaming operation can be smoothly carried out by suitably moving the support table.

It will be understood from the above that according to the present invention, in winding a fabric to be treated on a take-up frame either singly or with an undercloth placed under said fabric, the winding is divided into several separate stratum of suitable thickness suitably spaced apart from each other and that during steaming operation, with the tension relieved the take-up reel is slowly rotated alternately in forward and reverse directions. Therefore, the contraction of

the fabric which takes place during steaming operation can be readily absorbed and steaming can be carried out always in a tensionless condition so that the steam uniformly acts on the fabric as far as the interior of the wound stratum. Further, hot steam is blown into the steam oven at predetermined intervals of time in such a manner as to alternately create higher and lower pressure conditions in the steam oven, the fabric can be uniformly treated throughout the area without any unevenness of color-development. Further, the take-up reel in the present invention comprises grooved support arms mounted on both ends of a rotary shaft in such a manner that said support arms extend radially with their open sides opposed to each other, and a member of bars. With this arrangement, since the winding of a fabric to be treated on the take-up reel is carried out by horizontally fitting said bars in said grooved support arms, the fabric can be easily wound with the winding divided into several separate stratum each carried on the associated bar. Further, since support cams formed with ridges and recesses are used to support a first group of bars on said ridges during winding so that the succeeding bars are stacked on said first group of bars to carry out the winding of the fabric, the relaxation of the tension on the fabric at the time of steaming operation can be positively effected by rotating the bar support cams so as to support the bars in the recesses. Further, since take-up reel is slowly rotated alternately in forward and reverse directions, the position of contact between the bar and the fabric to be treated is deviated little by little to avoid unevenness of treatment due to bar contact. Further, the lateral shifting and wrinkling of the wound stratum can also be avoided.

In the present invention, the steam oven used is of the horizontal type wherein the support table for the take-up reel is adapted to be capable of being taken in and out of the steam oven, and in some cases, a turntable for rail connection purposes may be provided. Therefore, with a spare take-up reel provided, the treatment with steam can be effected continuously from the winding of the fabric and hence the efficiency of treatment is high. Further, fabrics of greater width can be treated. High-quality finish is always assured.

While there have been described herein what are at present considered preferred embodiments of the several features of the invention, it will be obvious to those skilled in the art that modifications and changes may be made without departing from the essence of the invention.

It is therefore to be understood that the exemplary embodiments thereof are illustrative and not restrictive of the invention, the scope of which is defined in the appended claims and that all modifications that come within the meaning and range of equivalency of the claims are intended to be included therein.

We claim:

1. Apparatus for use in treating dyed fabric with steam to fix the dye thereof comprising a horizontally positioned steam autoclave, a closure plate mounted at one end of said autoclave and openable to provide access thereto, a rotatable drive shaft positioned in one end of said autoclave and drivable by drive means positioned exteriorly of said autoclave, steam generating means positioned within said autoclave to pressurize same with steam, a support table positioned within said autoclave, said support table having means to permit its

ready insertion into or withdrawal from said autoclave, a winding reel mounted on said support table, said winding reel including a support shaft mounted on said support table and operably connected in detachable relationship to one end with one end of said drive shaft, a plurality of grooved support arms extending radially outwardly from each end of said support shaft, the support arms of one end being complementary with the support arms of the other end, with the groove of each of the support arms facing inwardly from one end toward the inwardly facing groove of its complementary arm, a plurality of fabric supporting bar means horizontally mounted with their opposite ends removably fitted in the grooves of each pair of complementary support arms and spanning the distance therebetween, a pair of bar support cams rotatably mounted on and coaxially with said support shaft, said bar support cams having alternate ridges and recesses formed around the peripheral surface thereof to support opposite ends of said bar means and means for rotating said cams to a predetermined position to receive the opposite ends of

5  
10  
15  
20

said bar means in the respective ridges or recesses.  
 2. Apparatus in accordance with claim 1, which further includes means for slowly rotating the winding reel alternately in forward and reverse direction during the steaming operation.  
 3. Apparatus in accordance with claim 1, wherein suction means are operatively connected to said autoclave to evacuate same.  
 4. Apparatus in accordance with claim 1, wherein said bars have rollers provided at each end thereof so as to maintain said bars in spaced apart relationship.  
 5. Apparatus in accordance with claim 1, which further includes winding means positioned exteriorly of said autoclave, said winding means including a bar supply means for inserting a number of bars into complementary grooved support arms successively and intermittently at predetermined intervals of time, fabric feeding means for feeding a fabric on said winding means, and drive means for rotating said winding means.

\* \* \* \* \*

25  
  
30  
  
35  
  
40  
  
45  
  
50  
  
55  
  
60  
  
65